

NHD-5.7-320240WFB-ATXI#-1

TFT (Thin-Film-Transistor) Color Liquid Crystal Display Module

NHD-	Newhaven Display
5.7-	5.7" Diagonal
320240-	320xRGBx240 pixels
WFB-	Model
A-	Built-in driver, No Controller
T-	White LED backlight
X-	TFT
I-	6:00 view, Wide Temp
#-1	RoHS Compliant

Newhaven Display International, Inc.

2511 Technology Drive, Suite 101

Elgin IL, 60124

Ph: 847-844-8795

Fax: 847-844-8796

www.newhavendisplay.com

nhtech@newhavendisplay.com

nhsales@newhavendisplay.com

Document Revision History

Revision	Date	Description	Changed by
0	5/23/2012	Initial Release	AK
1	5/29/2012	Optical characteristics updated	AK

Functions and Features

- 320xRGBx240 resolution
- LED backlight
- 24-bit Parallel RGB interface
- Built-in Source Driver: HX8218-A
- Built-in Gate Driver: HX8615

Mechanical Drawing

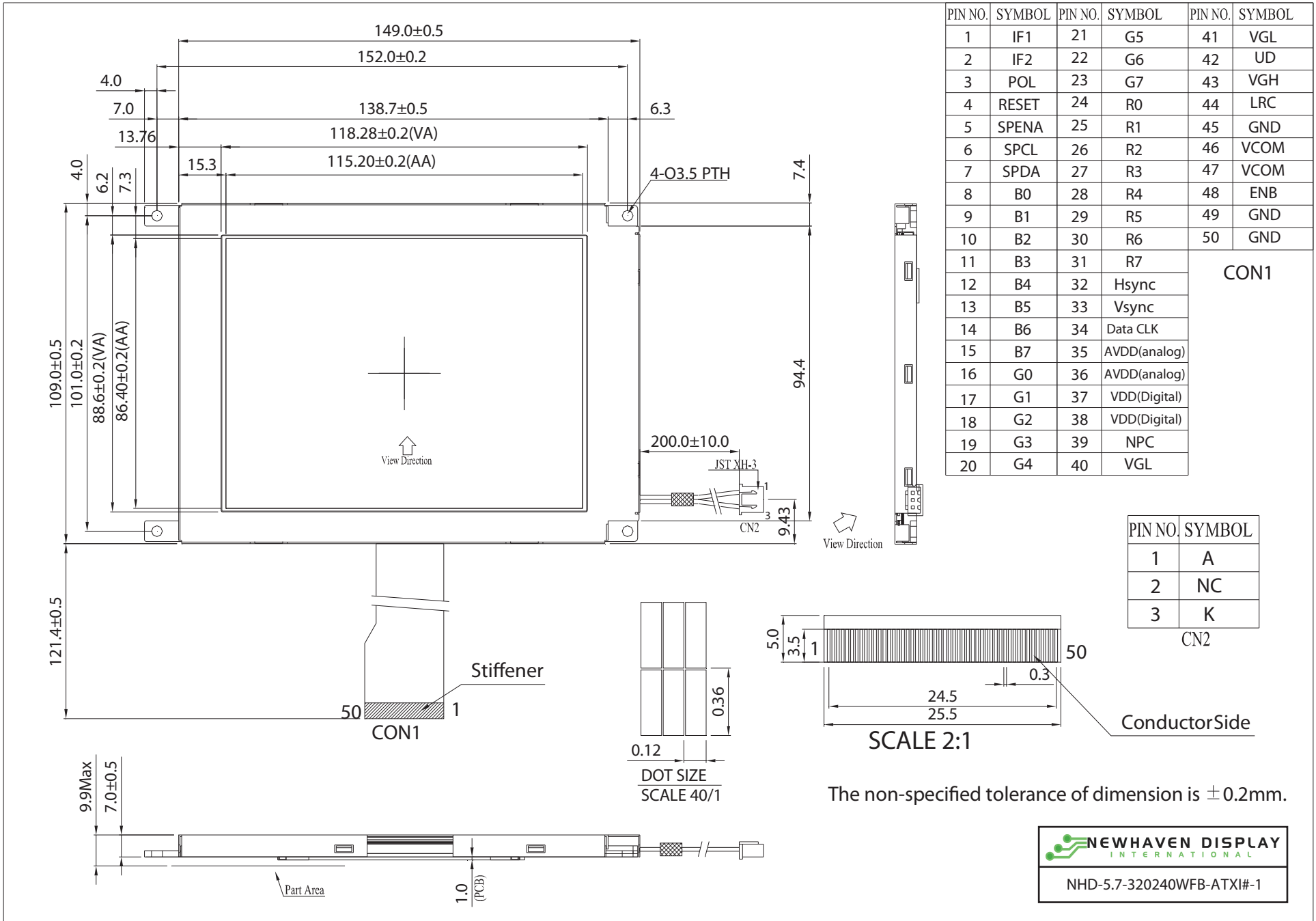

PIN NO.	SYMBOL	PIN NO.	SYMBOL	PIN NO.	SYMBOL
1	IF1	21	G5	41	VGL
2	IF2	22	G6	42	UD
3	POL	23	G7	43	VGH
4	RESET	24	R0	44	LRC
5	SPENA	25	R1	45	GND
6	SPCL	26	R2	46	VCOM
7	SPDA	27	R3	47	VCOM
8	B0	28	R4	48	ENB
9	B1	29	R5	49	GND
10	B2	30	R6	50	GND
11	B3	31	R7	CON1	
12	B4	32	Hsync		
13	B5	33	Vsync		
14	B6	34	Data CLK		
15	B7	35	AVDD(analog)		
16	G0	36	AVDD(analog)		
17	G1	37	VDD(Digital)		
18	G2	38	VDD(Digital)		
19	G3	39	NPC		
20	G4	40	VGL		

PIN NO.	SYMBOL
1	A
2	NC
3	K

CN2

The non-specified tolerance of dimension is ±0.2mm.



Pin Description

Pin No.	Symbol	I/O	Description	Remark
1	IF1	I	Input data format control (Note1)	Note1
2	IF2	I	Input data format control (Note1)	Note1
3	POL	O	Polarity Signal connect to VCOM driving circuit.	Note3
4	RESET	I	Hardware reset.	
5	SPENA	I	Chip select	Note2
6	SPCL	I	Serial Clock	Note2
7	SPDA	I/O	Serial Data	
8	B0	I	Blue Data bit (LSB)	
9	B1	I	Blue Data bit	
10	B2	I	Blue Data bit	
11	B3	I	Blue Data bit	
12	B4	I	Blue Data bit	
13	B5	I	Blue Data bit	
14	B6	I	Blue Data bit	
15	B7	I	Blue Data bit(MSB)	
16	G0	I	Green Data bit(LSB)	
17	G1	I	Green Data bit	
18	G2	I	Green Data bit	
19	G3	I	Green Data bit	
20	G4	I	Green Data bit	
21	G5	I	Green Data bit	
22	G6	I	Green Data bit	
23	G7	I	Green Data bit(MSB)	
24	R0	I	Red Data bit(LSB)	
25	R1	I	Red Data bit	
26	R2	I	Red Data bit	
27	R3	I	Red Data bit	
28	R4	I	Red Data bit	
29	R5	I	Red Data bit	
30	R6	I	Red Data bit	
31	R7	I	Red Data bit(MSB)	
32	Hsync	I	Horizontal synchronous signal	
33	Vsync	I	Vertical synchronous signal	
34	Data CLK	I	Dot data clock	
35	AVDD(analog)	I	Analog power: 4.5V-5.5V	
36	AVDD(analog)	I	Analog power: 4.5V-5.5V	
37	VDD(digital)	I	Digital power: 3V-3.5V	
38	VDD(digital)	I	Digital power: 3V-3.5V	
39	NPC	O	NTSC/PAL mode Auto detection result H:NTSC/L:PAL	
40	VGL	I	Gate off power	
41	VGL	I	Gate off power	
42	UD	I	Up/Down scan setting. H: Reverse scan / L: Normal scan	
43	VGH	I	Gate on power	
44	LRC	I	Shift direction of device internal shift register control.	
45	GND	I	GROUND	
46	VCOM	I	VCOM driving input	Note3
47	VCOM	I	VCOM driving input	
48	ENB	I	Data enable input. Normally pull low.	Note4
49	GND	I	GROUND	
50	GND	I	GROUND	

Recommended LCD connector: 50-pin, 0.5mm pitch FFC connector. Molex 54132-5097

Backlight:

Pin No.	Symbol	Connection	Description
1	VDD	Power Supply	Red, LED Anode (140mA @ 9.9V)
2	NC	-	No Connect
3	VSS	Power Supply	White, LED Cathode

Backlight connector: JST p/n: XHP-3 **Mates with:** JST p/n: B 3B-XH-A

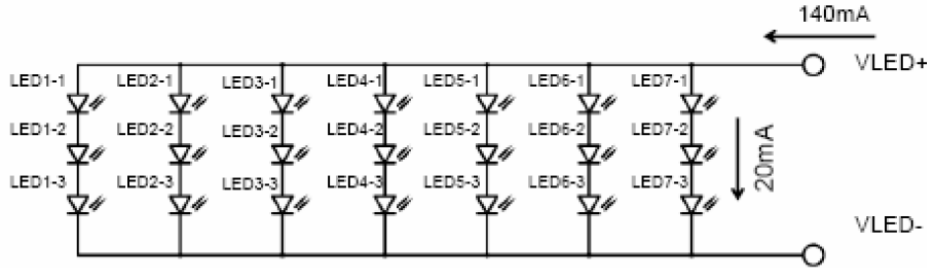

Note 1: Input data format

IF2, IF1	Input data format
L,L (default)	Serial RGB
L,H	Parallel RGB
H,L	CCIR601
H,H	CCIR656

Note 2: Pins 5 and 6 typically pulled high

Note 3: Polarity of VCOM (pins 46,47) should be generated from POL (pin 3)

Note 4: For digital RGB input data format, both SYNC mode and DE+SYNC mode are supported. If ENB signal is fixed low, SYNC mode is used. Otherwise, DE+SYNC mode is used.

Note 5: The phase of POL (pin 3):

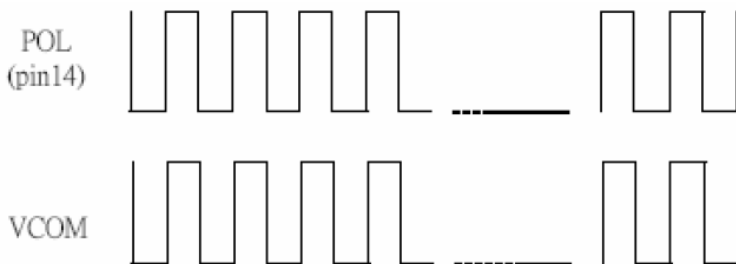

Driver Information

Built-in Source Driver HX8218-A: http://www.newhavendisplay.com/app_notes/HX8218.pdf

Built-in Gate Driver HX8615: http://www.newhavendisplay.com/app_notes/HX8615.pdf

Electrical Characteristics

Item	Symbol	Condition	Min.	Typ.	Max.	Unit
Operating Temperature Range	Top	Absolute Max	-20	-	+70	°C
Storage Temperature Range	Tst	Absolute Max	-30	-	+80	°C
Supply Voltage for Logic	VDD		3.0	3.3	3.5	V
Supply Voltage for Analog	AVDD		4.5	5	5.5	V
“H” Level input	Vih		0.7*VDD	-	VDD	V
“L” Level input	Vil		0	-	0.3*VDD	V
TFT Gate ON operating voltage	VGH	Duty=1/240	-	15	-	V
TFT Gate OFF operating voltage	VGL	Duty=1/240	-	-10	-	V
VCOM driving voltage (Note 6)	VCOM	Duty=1/240	-2.0	-	5.5	V
Supply Current for Digital	IDD	VDD=3.3V,	-	2.2	3.5	mA
Supply Current for Analog	IAVDD	AVDD=5V,	-	4.7	7	mA
Supply Current for Gate ON	IGH	VGH=15V,	-	0.05	0.1	mA
Supply Current for Gate OFF	IGL	VGL=-10V	-	0.05	0.1	mA
Backlight Supply Voltage	VLED		9.0	9.9	10.5	V
Backlight Supply Current	ILED	VLED=9.9V	-	140	210	mA
Backlight Lifetime			-	50K		Hr

Note 6: VCOM must be adjusted to optimize display quality, contrast ratio, etc.

Optical Characteristics

Item	Symbol	Condition	Min.	Typ.	Max.	Unit
Viewing Angle – Top (Note 7)		Cr ≥ 5	40	60		°
Viewing Angle – Bottom (Note 7)		Cr ≥ 5	60	70		°
Viewing Angle – Left		Cr ≥ 5	60	70		°
Viewing Angle – Right		Cr ≥ 5	60	70		°
Contrast Ratio	Cr		-	250	-	
Luminance	YL		300	-	-	cd/m ²
Response Time (rise)	Tr	-	-	15		ms
Response Time (fall)	Tf	-	-	35		ms

Note 7: Viewing direction – 12:00; Gray Scale inversion direction – 6:00.

Timing Characteristics

CCIR601/656 Interface

Input Signal Characteristics

PARAMETER	Symbol	Min.	Typ.	Max.	Unit
CLK period	T_{OSC}	-	37	-	ns
Data setup time	T_{SU}	12	-	-	ns
Data hold time	T_{HD}	12	-	-	ns

Hardware Reset Timing

PARAMETER	Symbol	Min.	Typ.	Max.	Unit
RESET low pulse width	T_{RSB}	10	-	-	μ S

Output Signal Characteristics

PARAMETER	Symbol	Min.	Typ.	Max.	Unit
Rising time	T_r	-	-	10	ns
Falling time	T_f	-	-	10	ns
Internal STH setup time	T_{SUS}	12	-	-	ns
Internal STH hold time	T_{HDS}	12	-	-	ns
Internal data setup time	T_{SUD}	60	-	-	ns
Internal data hold time	T_{HDD}	40	-	-	ns
OEH pulse width	T_{OEH}	-	1248	-	ns
OEV pulse width	T_{OEV}	-	4992	-	ns
CKV pulse width	T_{CKV}	-	3744	-	ns
Hsync – DEH time	T_1	-	4368	-	ns
Hsync – CKV time	T_2	-	2496	-	ns
Hsync – OEV time	T_3	-	624	-	ns
Vsync – setup time	T_{SUV}		1872	-	ns
Vsync – pulse time	T_{STV}		1	-	T_H
Vsync – STV time	NTSC		19	-	T_H
	PAL		27	-	T_H
OEH – STV time	T_{HE}	-	2	-	T_H
Output settling time	T_{OES}	-	12	20	μ S

24-bit Parallel RGB Interface

AC Timing Characteristics

Signal	Item		Symbol	Min	Typ	Max	Unit
Dclk	Frequency		Dclk	-	6.4	-	MHZ
	High Time		Tch	-	78	-	ns
	Low Time		Tcl	-	78	-	ns
Data	Setup Time		Tds	12	-	-	ns
	Hold Time		Tdh	12	-	-	ns
Hsync	Period		TH	-	408	-	DCLK
	Pulse Width		Thp	-	30	-	DCLK
	Back-Porch		Thb	-	38	-	DCLK
	Display Period		Thd	-	320	-	DCLK
	Front-Porch		Thf	-	20	-	DCLK
Vsync	Period	NTSC	Tv	-	262.5	-	TH
		PAL			312.5		
	Pulse Width		Tvp	1	3	5	TH
	Back-Porch	NTSC	Tvb	-	15	-	TH
		PAL			23		
	Display Period		Tvd	-	240	-	TH
	Front-Porch	NTSC	Tvf	-	4.5	-	TH
PAL		46.5					

AC Timing Diagrams

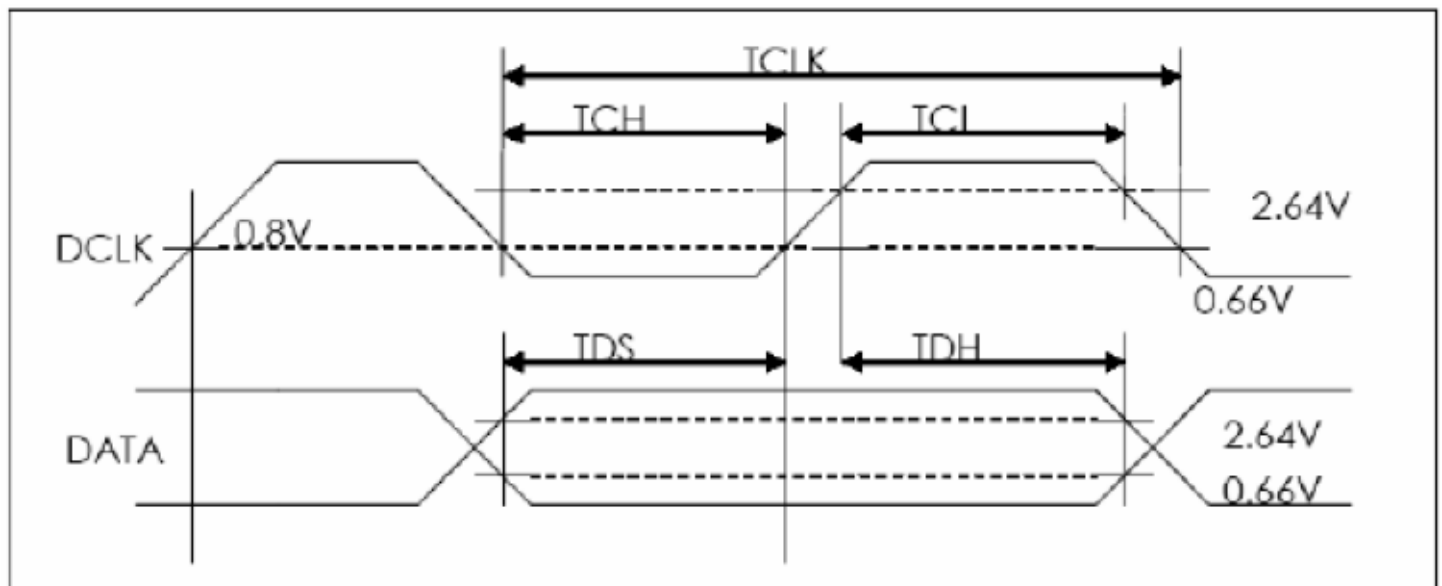
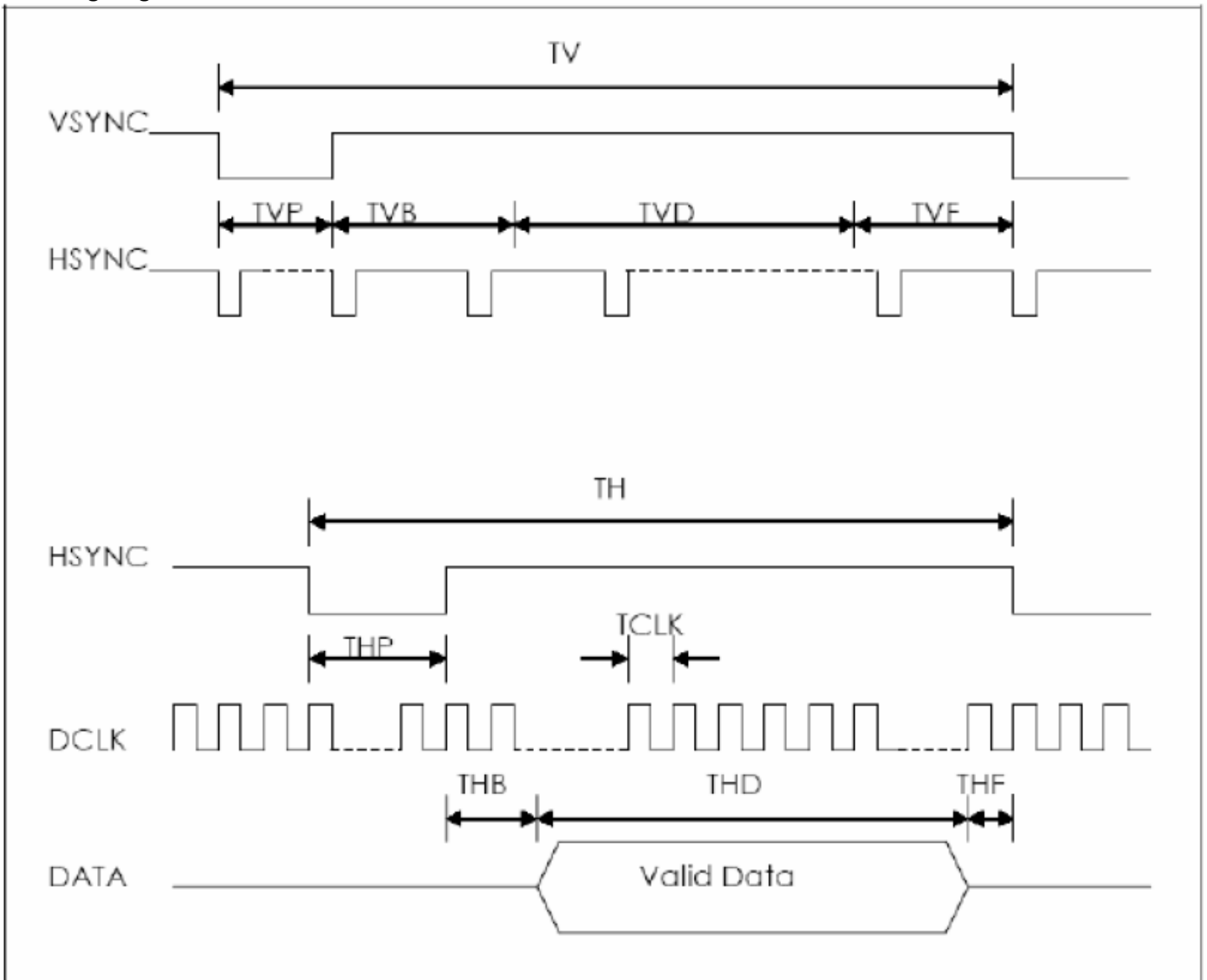

Waveforms

Clock and Data waveform

- CCIR601(HS_POL="L" in Register R2)

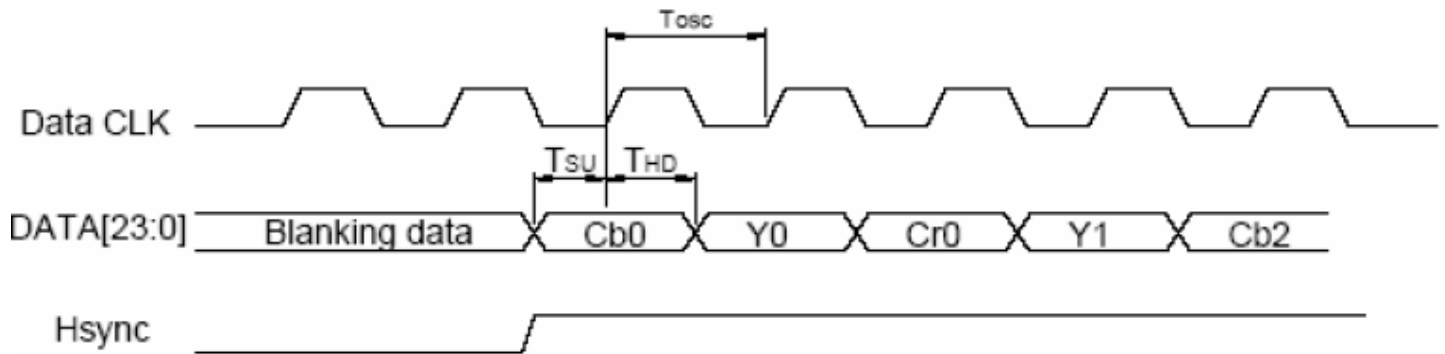

- CCIR656

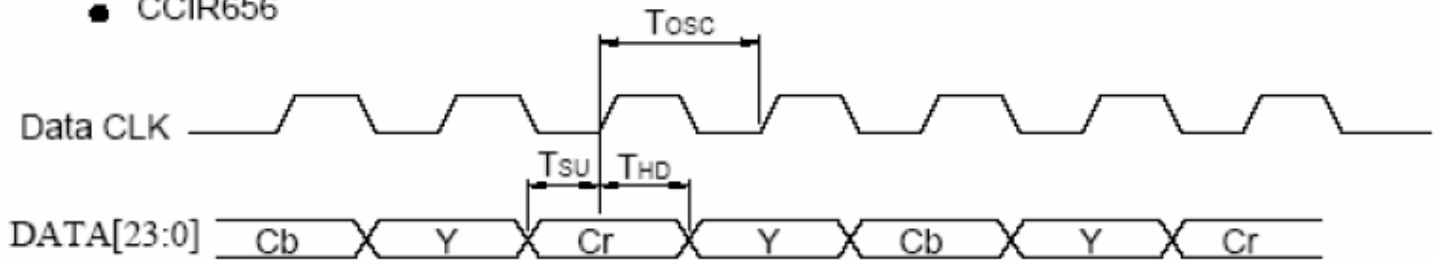

Digital/Analog RGB timing waveform

Hsync and Vsync Timing

- Odd field

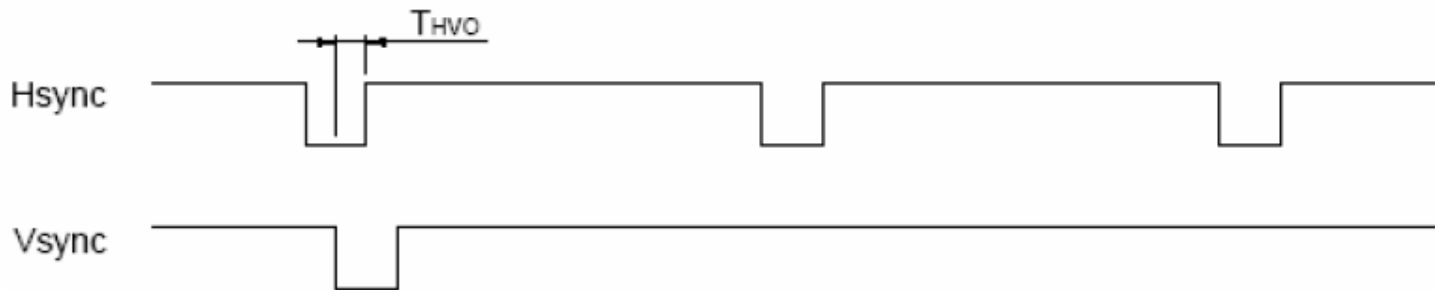

- Even field

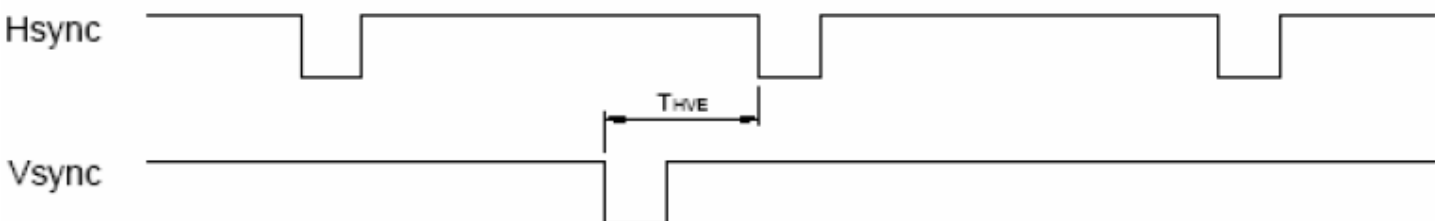

Hsync and Horizontal Control Timing Waveform

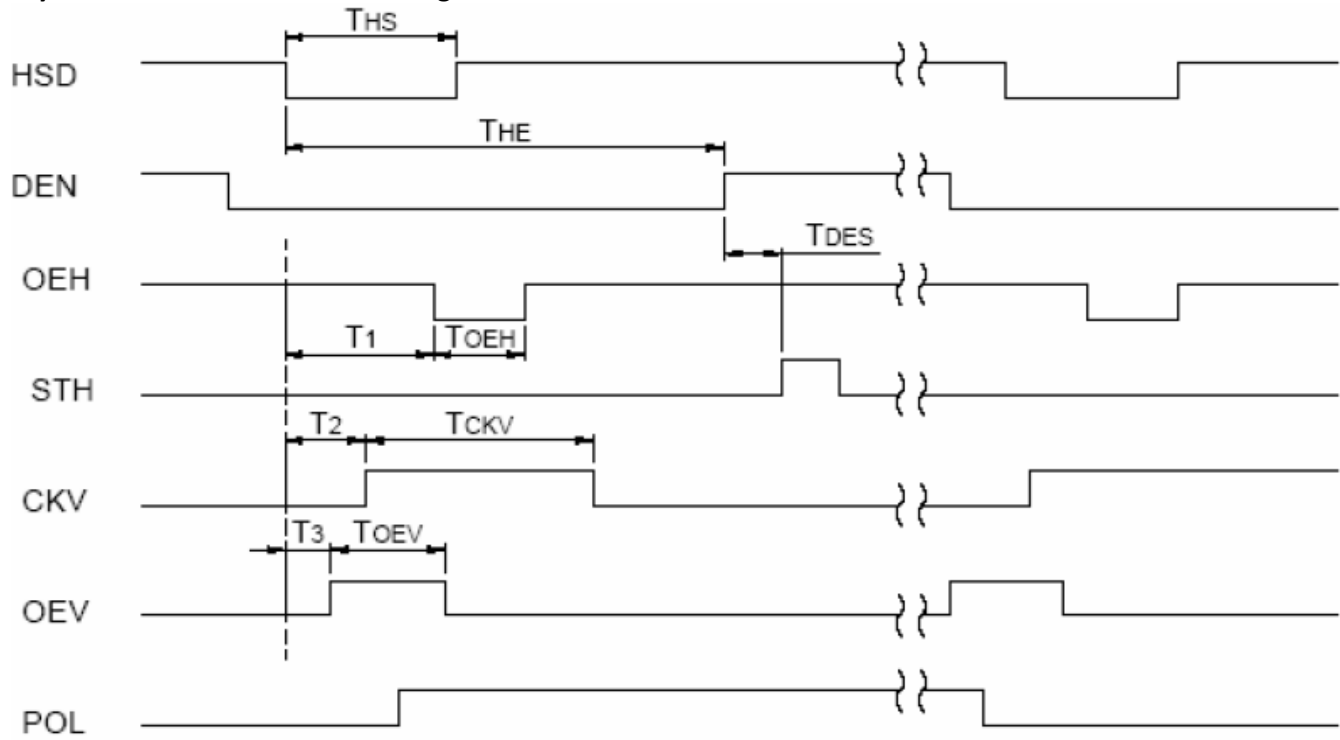

Hsync and Vertical Shift Clock Timing Waveform

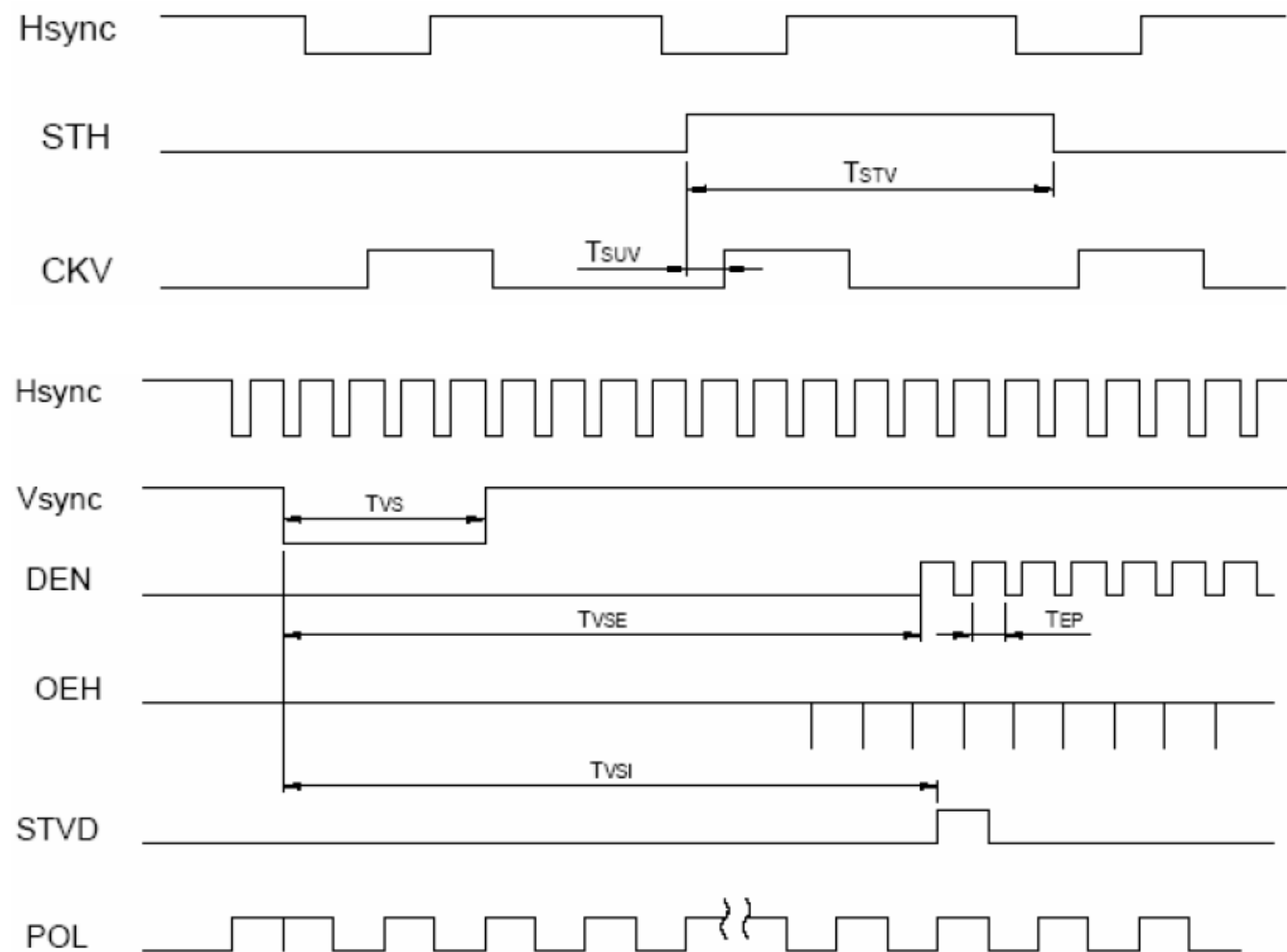

CCIR601 Timing Waveform (VS_POL = "H", HS_POL = "L" in register R2)

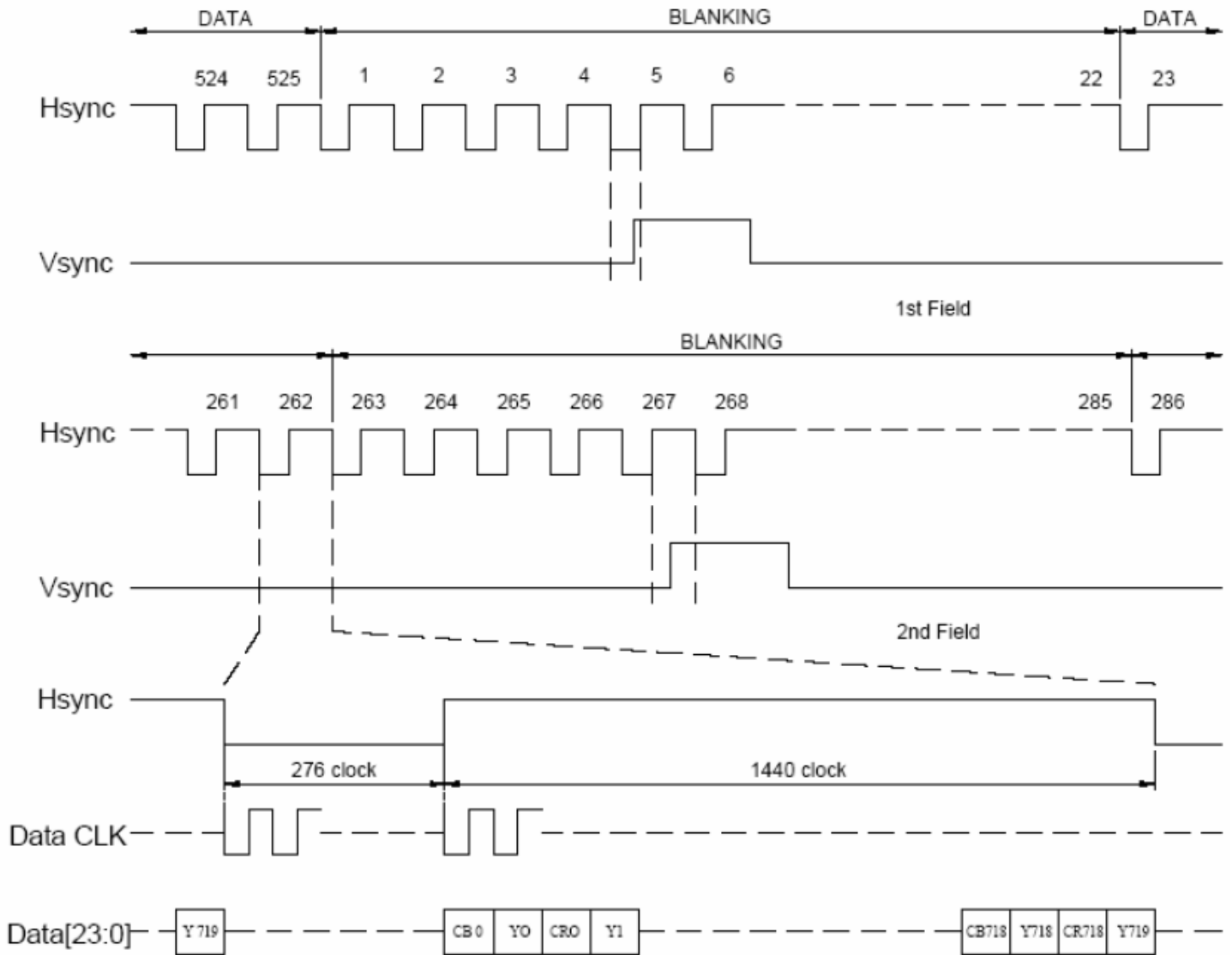

ITU-BT.601 NTSC Input Timing

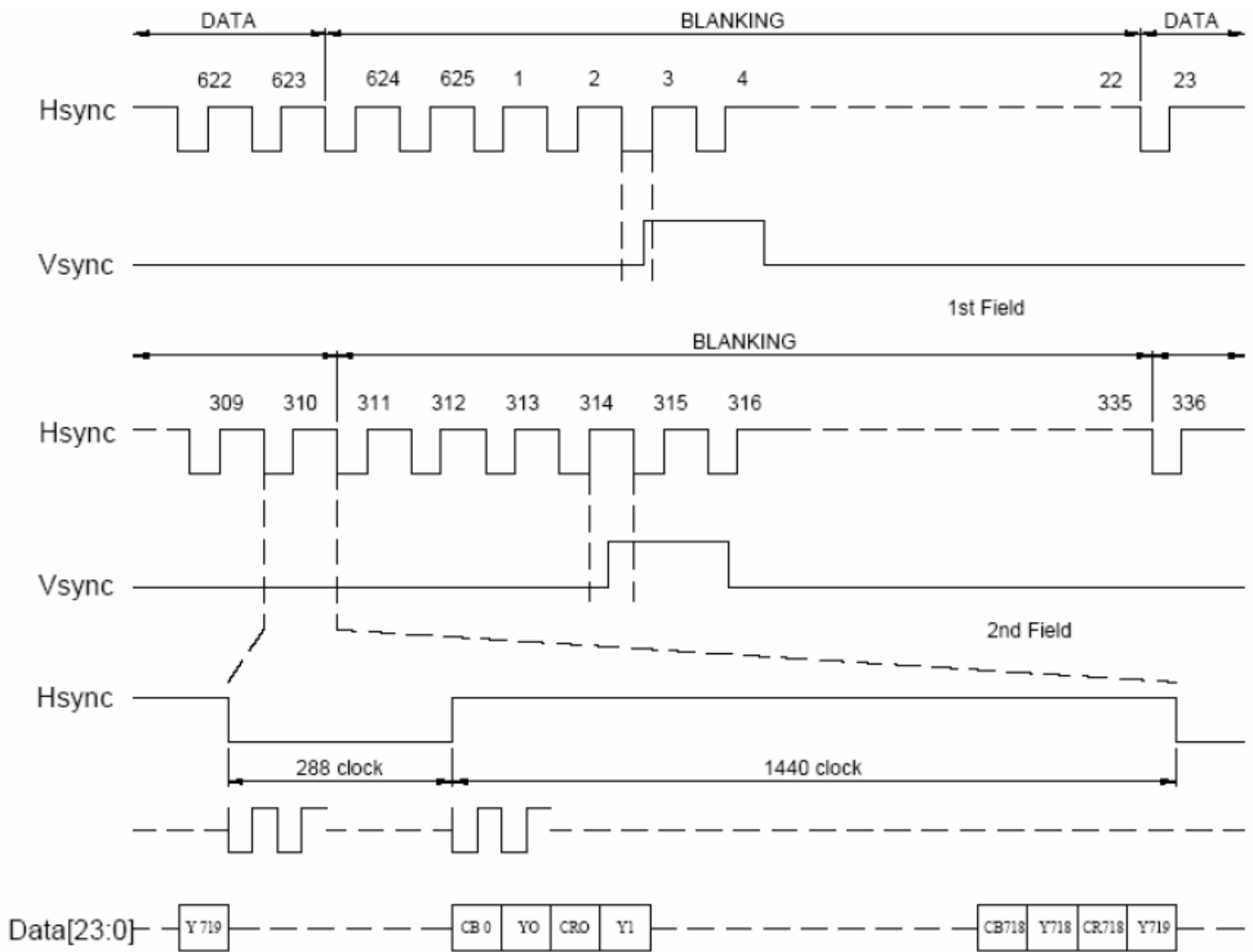

ITU-BT.601 PAL Input Timing

Clock and Start Pulse Timing Waveform

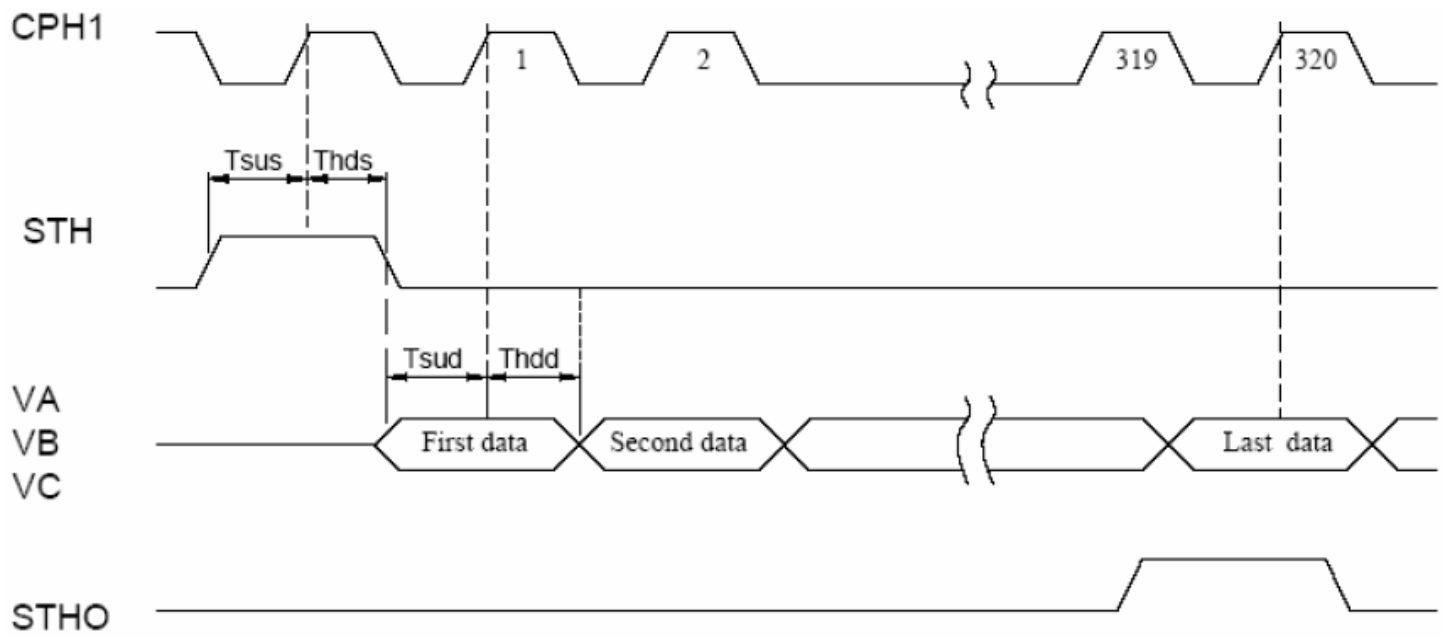

OEH and Data Output timing Waveform

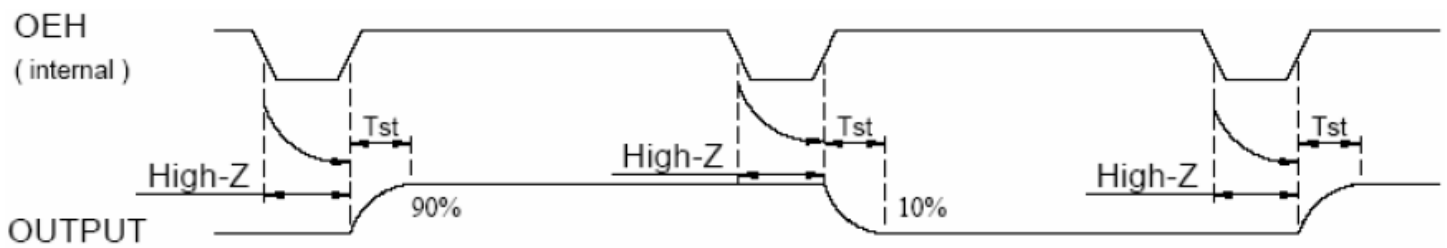

Analog Video Signal Characteristics

PARAMETER	Symbol	Min.	Typ.	Max.	Unit
Video signal amplitude (VA, VB, VC)	V_{IAC}	-	3.81	-	V
	V_{IDC}	-	2.385	-	V

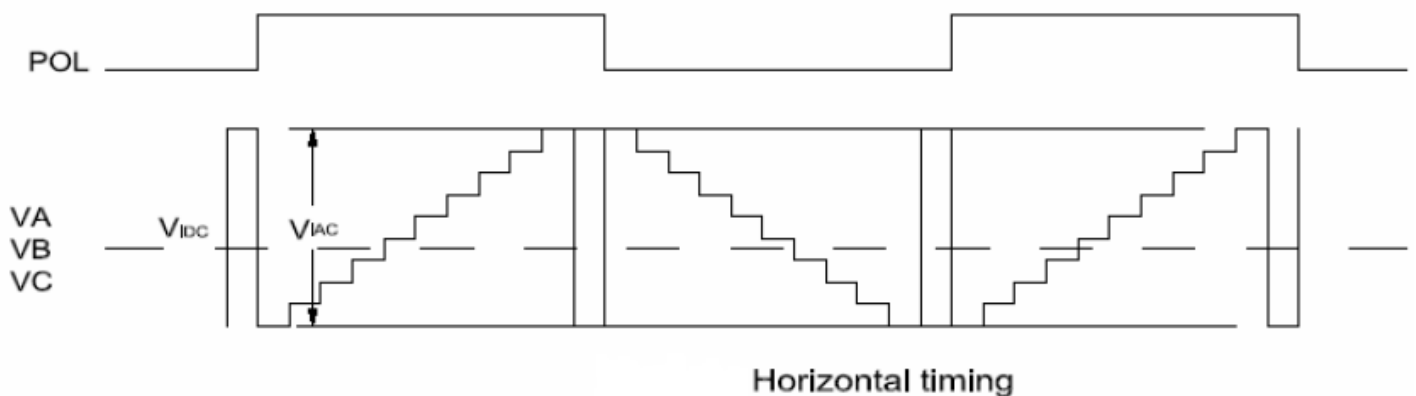

SPI Timing Characteristics

PARAMETER	Symbol	Min.	Typ.	Max.	Unit
SPCL period	T_{CK}	60	-	-	ns
SPCL high width	T_{CKH}	30	-	-	ns
SPCL low width	T_{CKL}	30	-	-	ns
Data setup time	T_{SU1}	12	-	-	ns
Data hold time	T_{HD1}	12	-	-	ns
SPENA to SPCK setup time	T_{CS}	20	-	-	ns
SPENA to SPDA hold time	T_{CE}	20	-	-	ns
SPENA high pulse width	T_{CD}	50	-	-	ns
SPDA output latency	T_{CR}		1/2	-	T_{CK}

● SPI "read" timing

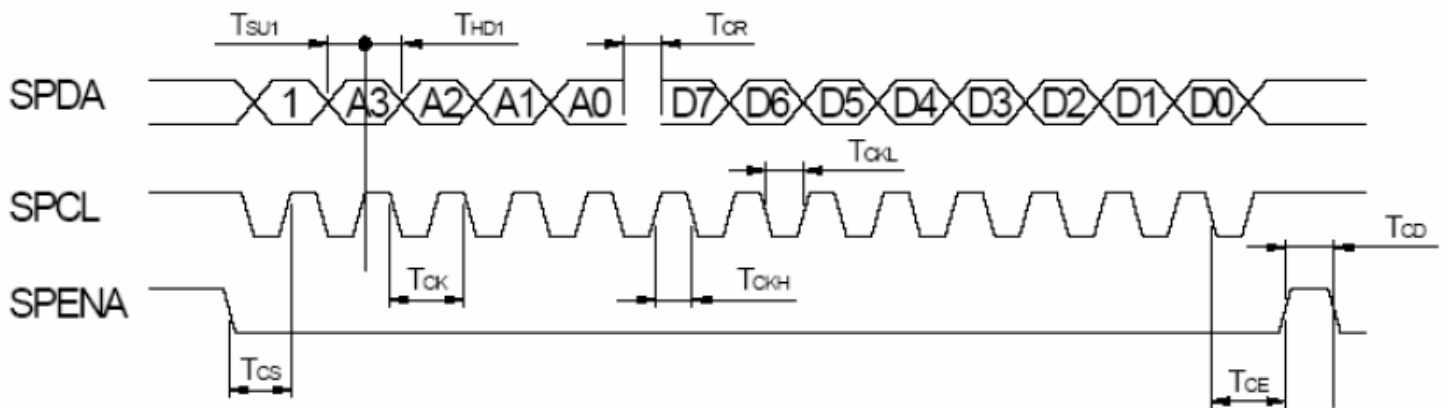

● SPI "write" timing

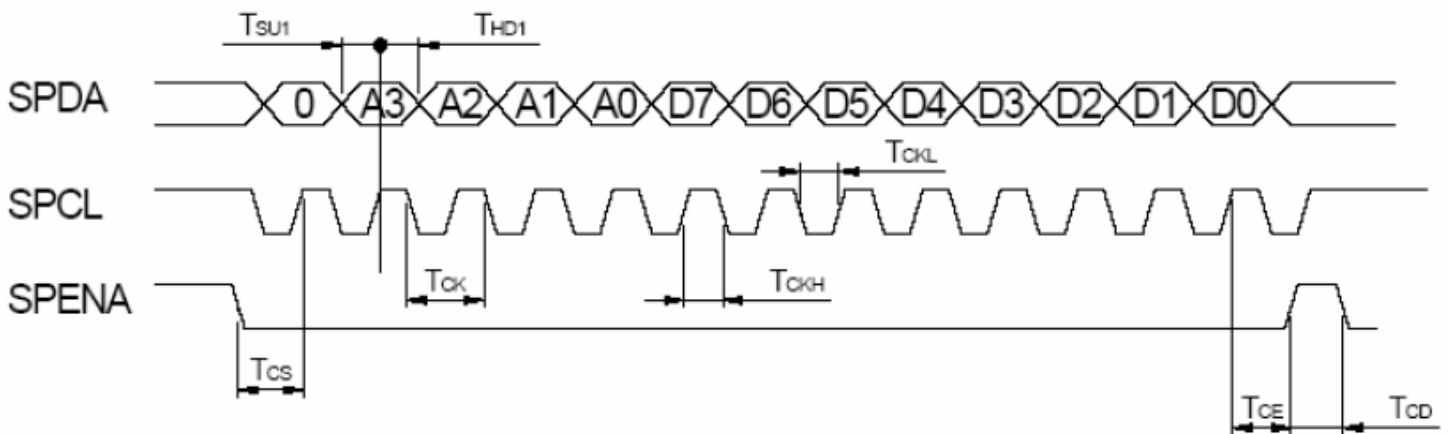

Gate Driver Timing Chart

Parameter	Symbol	Condition	Spec		Unit
			Min.	Max.	
Operation frequency	tCPV		5	-	μ s
CPV pulse width	tCPVH,tCPVL	50%duty cycle	2.5	-	
OE pulse width	twOE		1	-	
Data setup time	tsu		0.4	-	us
Data hold time	thd		0.7	-	
Output delay time	tpd1	CL=300pF	-	1	
Output delay time	tpd2	CL=300pF	-	0.8	
Output delay time	tpd3	CL=300pF	-	0.8	
Output delay time	tpd4	CL=300pF	-	10	

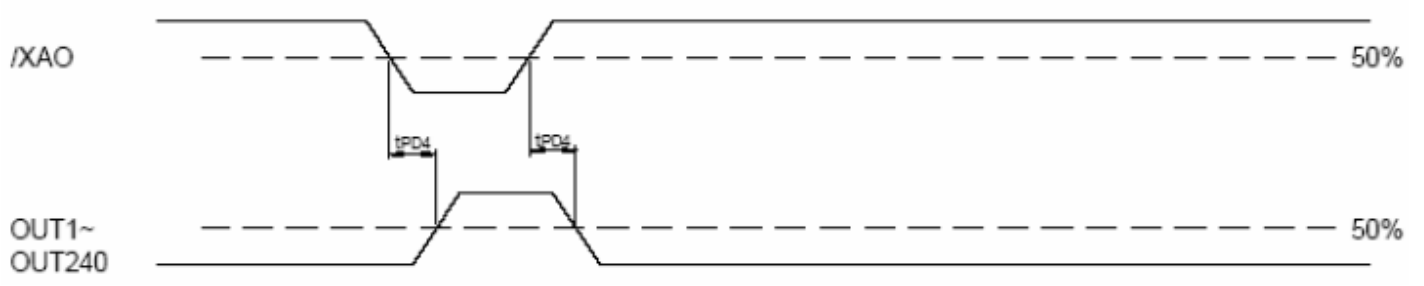
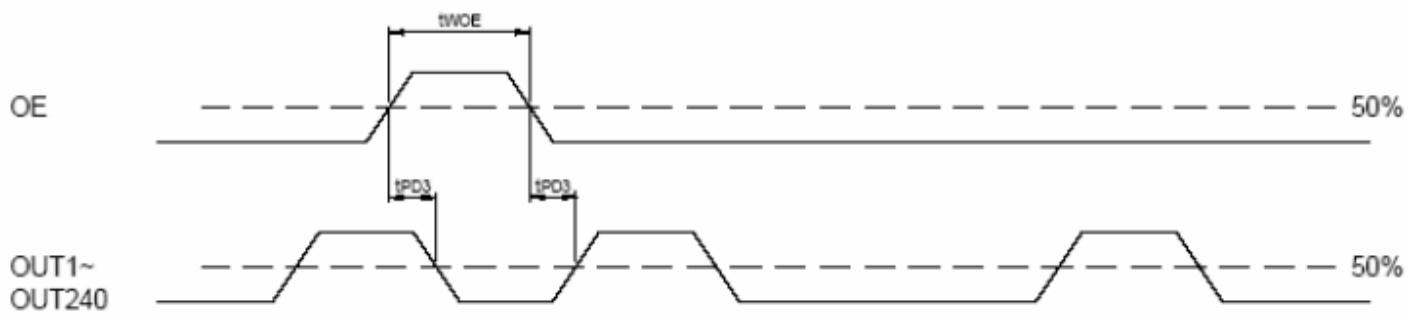
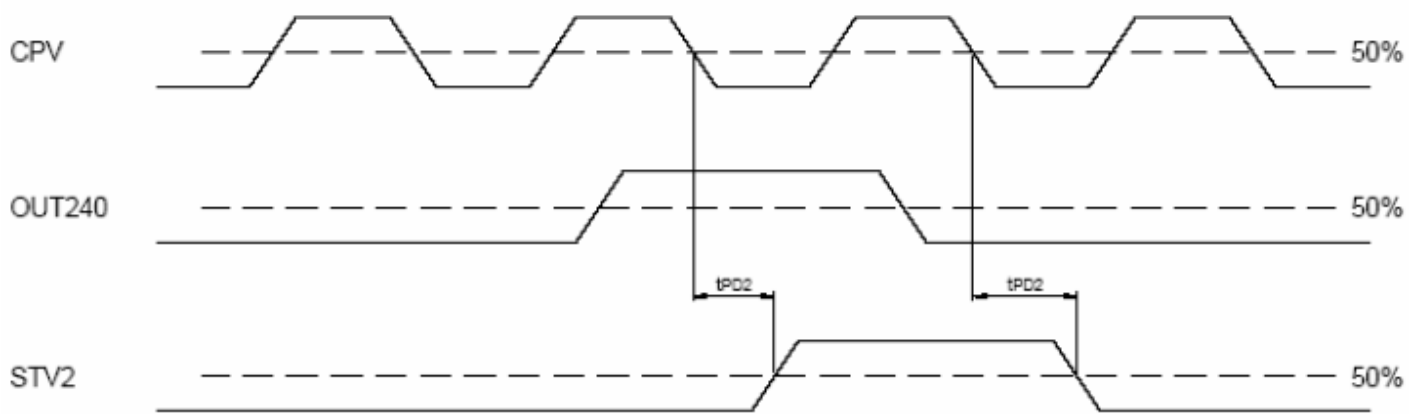
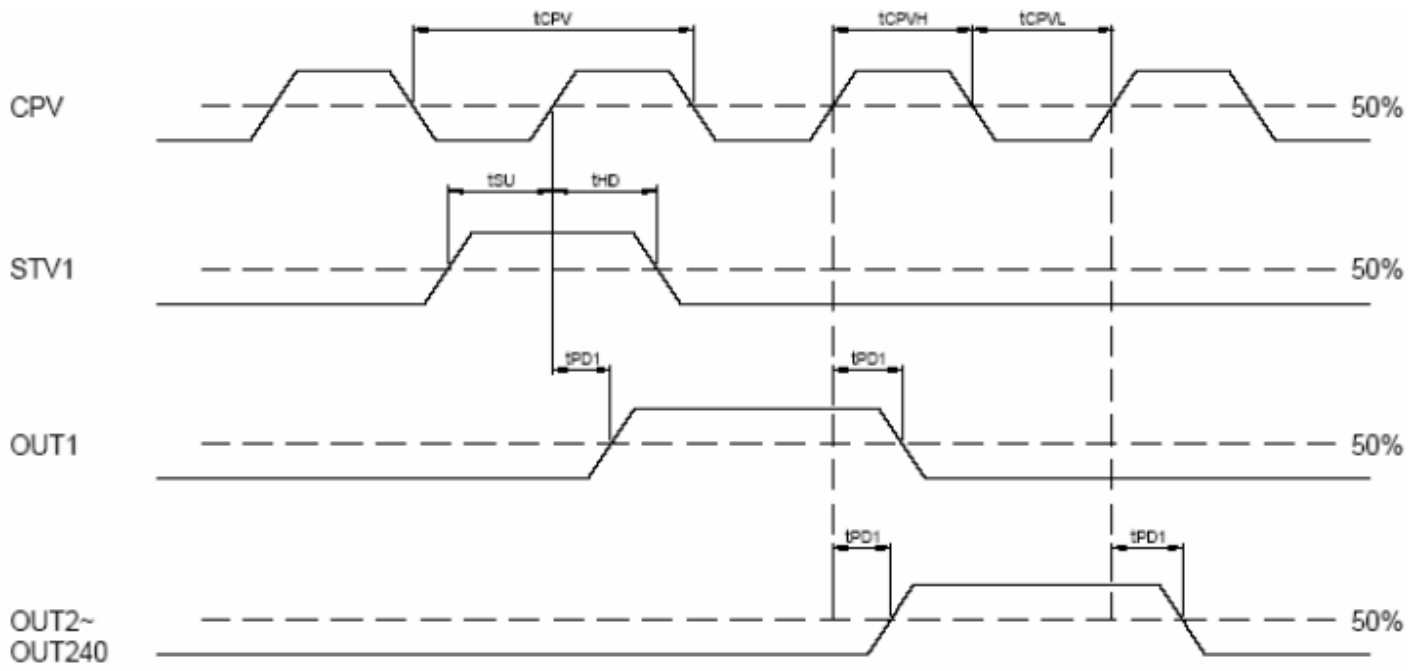

Quality Information

Test Item	Content of Test	Test Condition	Note
High Temperature storage	Endurance test applying the high storage temperature for a long time.	+80°C , 240hrs	2
Low Temperature storage	Endurance test applying the low storage temperature for a long time.	-30°C , 240hrs	1,2
High Temperature Operation	Endurance test applying the electric stress (voltage & current) and the high thermal stress for a long time.	+70°C 240hrs	2
Low Temperature Operation	Endurance test applying the electric stress (voltage & current) and the low thermal stress for a long time.	-20°C , 240hrs	1,2
High Temperature / Humidity Operation	Endurance test applying the electric stress (voltage & current) and the high thermal with high humidity stress for a long time.	+60°C , 90% RH , 240hrs	1,2
Thermal Shock resistance	Endurance test applying the electric stress (voltage & current) during a cycle of low and high thermal stress.	-20°C,30min -> 25°C,5min -> 70°C,30min = 1 cycle 10 cycles	
Vibration test	Endurance test applying vibration to simulate transportation and use.	10-55Hz , 15mm amplitude. 60 sec in each of 3 directions X,Y,Z For 15 minutes	3
Static electricity test	Endurance test applying electric static discharge.	VS=800V, RS=1.5kΩ, CS=100pF One time	

Note 1: No condensation to be observed.

Note 2: Conducted after 4 hours of storage at 25°C, 0%RH.

Note 3: Test performed on product itself, not inside a container.

Precautions for using LCDs/LCMs

See Precautions at www.newhavendisplay.com/specs/precautions.pdf

Warranty Information and Terms & Conditions

http://www.newhavendisplay.com/index.php?main_page=terms



Компания «ЭлектроПласт» предлагает заключение долгосрочных отношений при поставках импортных электронных компонентов на взаимовыгодных условиях!

Наши преимущества:

- Оперативные поставки широкого спектра электронных компонентов отечественного и импортного производства напрямую от производителей и с крупнейших мировых складов;
- Поставка более 17-ти миллионов наименований электронных компонентов;
- Поставка сложных, дефицитных, либо снятых с производства позиций;
- Оперативные сроки поставки под заказ (от 5 рабочих дней);
- Экспресс доставка в любую точку России;
- Техническая поддержка проекта, помощь в подборе аналогов, поставка прототипов;
- Система менеджмента качества сертифицирована по Международному стандарту ISO 9001;
- Лицензия ФСБ на осуществление работ с использованием сведений, составляющих государственную тайну;
- Поставка специализированных компонентов (Xilinx, Altera, Analog Devices, Intersil, Interpoint, Microsemi, Aeroflex, Peregrine, Syfer, Eurofarad, Texas Instrument, Miteq, Cobham, E2V, MA-COM, Hittite, Mini-Circuits, General Dynamics и др.);

Помимо этого, одним из направлений компании «ЭлектроПласт» является направление «Источники питания». Мы предлагаем Вам помощь Конструкторского отдела:

- Подбор оптимального решения, техническое обоснование при выборе компонента;
- Подбор аналогов;
- Консультации по применению компонента;
- Поставка образцов и прототипов;
- Техническая поддержка проекта;
- Защита от снятия компонента с производства.



Как с нами связаться

Телефон: 8 (812) 309 58 32 (многоканальный)

Факс: 8 (812) 320-02-42

Электронная почта: org@eplast1.ru

Адрес: 198099, г. Санкт-Петербург, ул. Калинина, дом 2, корпус 4, литера А.