



MIC2196 LED Driver Evaluation Board

Boost LED Driver w/PWM DIM Control

General Description

The MIC2196 current mode boost controller is used to implement a LED Driver with PWM DIM control (Figure 1). The LED series string is pulsed on and off by the PWM DIM input signal to provide true PWM dimming. When pulsed on the LED, current is regulated by the high frequency current mode boost converter. The converter is designed as a constant current not a constant voltage output boost converter. The under voltage lockout is used to prevent operation below about 9.5V. The input of the converter is 12V nominal and the output can be from 17V to 30Vdc. The LED current can be set by selecting the value of R3 (Table 2). The maximum input voltage to the MIC2196 is 16V. Table 1 provides a summary of the specifications. The evaluation board schematic is shown in Figure 1 and the parts list is shown in the Bill of Materials table.

Specifications

	Max	Typ	Min
V _{IN}	16Vdc	12Vdc	10Vdc
Output voltage	30Vdc	22Vdc	17Vdc
Output current	1amp	700mA	0
Power out	30W	17W	0
efficiency		92%	
Output ripple	1Vpp		
Switching Freq		400kHz	
PWM control	100%		0
PWM Frequency	5kHz	300Hz	0Hz

Table 1. Design Specifications

Requirements

1. Voltage source at 3A
2. Pulse generator: TTL output, 100-300 HZ variable duty cycle
3. Load: LED string (series), a resistive or a electronic load (constant resistance mode)

Precautions

The evaluation board does not have input reverse polarity protection. Applying a negative voltage at the V_{IN} terminal may damage the board. When the controller is off there is

a current path through the inductor and through the fly back diode to the output. No current limit exists for this current path so care must be taken not to short circuit the output.

How it works

Switch Q3, turns off and on the current to the load. When the load current is turned on the boost converter regulates the load current by keeping the IR drop across R10+Q3_R_{DS(on)} constant. Q3's R_{DS(on)} is a low (about 1/10 of R10) compared to R10. When the load is off the converter turns off (FB pin is pulled high by R14). When the load current is turned off the input is connected to the output through L1 and D1. For 100% duty cycle, simply keep PWM DIM high (5V). For a different LED current change R3 using the following equation. When R3 is 2.15K the LED current is at 1A.

$$V_{FB} = V_{REF} = \frac{R3}{R3 + R14} V_Z + I_{LED} \times (R10 + Q3_{R_{DS(on)}})$$

(Approximate)

Where:

V_{REF} = 1.245

V_Z = 7.5V

R3 = 2.43k. (used on evaluation board)

R14 = 15k

R10 = 330mΩ

Q3_{R_{DS(on)}} = 34mΩ

R3	I_LED Measured	I_LED Calculated
2.15k	1.02amps	1A
2.21k	920mA	930mA
2.26k	860mA	870mA
2.32k	792mA	810mA
2.37k	744mA	760mA
2.43k	700mA	700mA
2.49k	616mA	640mA
2.55k	536mA	580mA
2.61k	490mA	520mA

Table 2. R3 Values

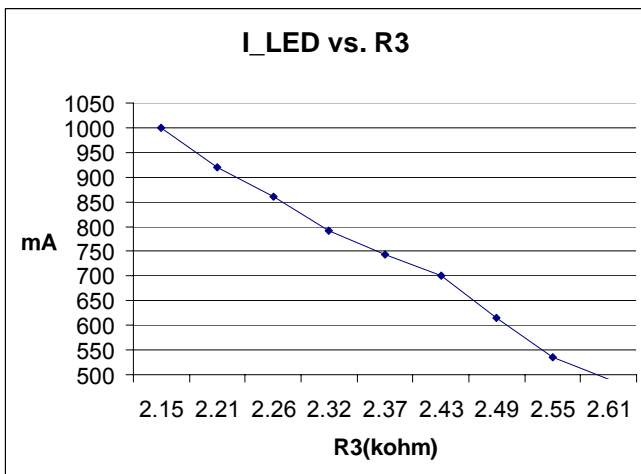

Plot 1. I_LED vs R3

Quick-Start Guide

1. Connect a load between V_{OUT} and RTN. (LED series string or resistive load)
2. Connect a function generator to the PWM DIM input and GND (not RTN). Set the output at 0-5V square wave pulse at 300Hz. Make sure the pulse goes all the way to 0V.
3. Connect 12V to V_{IN} and GND.
4. Use a current probe to measure the load current.

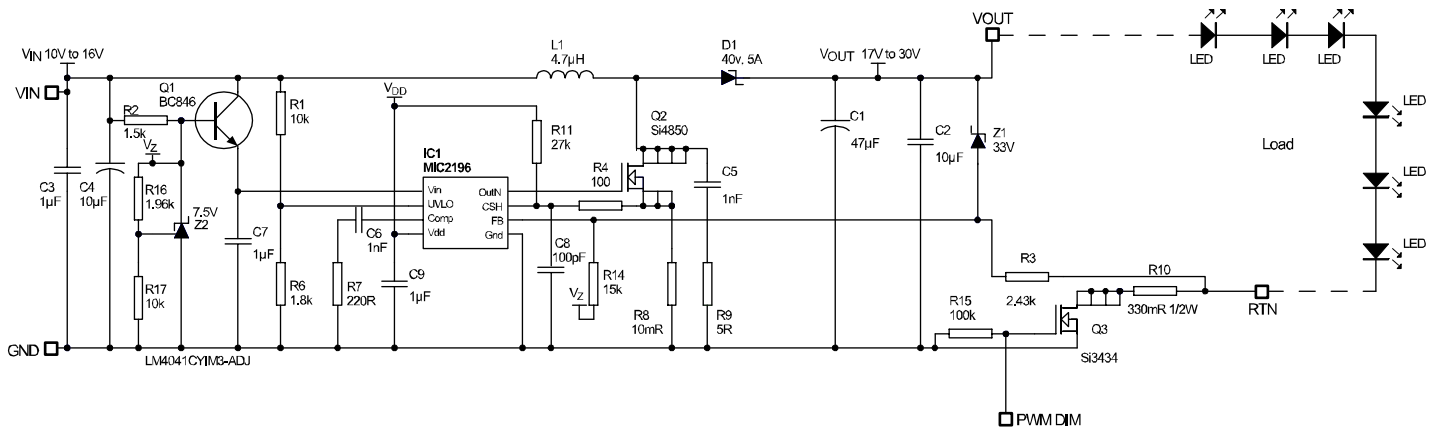

Figure 1. Schematic Diagram

Bill of Materials

Item	Part Number	Manufacturer	Description	Qty.
Z1	TZMC33	Vishay ⁽¹⁾	33V, 500mW, SOD-80, Zener diodes	1
	TZS4714	Vishay ⁽¹⁾		
	FLZ33VCC	Faichild Semiconductor ⁽²⁾		
Q1	BC846A	Diodes, Inc. ⁽³⁾	65v/100mA, NPN Silicon transistor	1
	BC846AMTF			
Q2	SI4484EY	Vishay Siliconix ⁽¹⁾	MOSFET	1
	SI4850EY			
Q3	SI3434DV	Vishay Siliconix ⁽¹⁾	N-MOSFET, 30V, 330 mil-Ohms	1
	SI3424DV			
D1	PDS540	Diodes, Inc. ⁽¹⁾	Schottky Diodes, 40V, 5A	1
	SSC54	Vishay ⁽¹⁾		
L1	CDR7D43MN-4R7NC.	Sumida ⁽⁴⁾	4.7µH, 6A inductor	1
C1	594D476X9035D2T	Vishay Sprague ⁽¹⁾	47µF/35V, D case	1
C2	GRM32DF51H106ZA01	MuRata ⁽⁵⁾	10µF/50V, 1210	1
	C3216X7R1H106M.	TDK ⁽⁶⁾		
C4	594D106X9035D2T	Vishay Sprague ⁽¹⁾	10µF/35V, D case	1
	594D156X9035D2T	Vishay Sprague ⁽¹⁾	15µF/35V, D case	
C5	VJ0805Y102KXAMT	Vishay Vitramon ⁽¹⁾	1000pF, 50V, X7R ceramic cap	1
C6	VJ0603Y102KXAMT	Vishay Vitramon ⁽¹⁾	1000pF, 50V, X7R ceramic cap	1
C3, C7, C9	GRM21BR71C105KA01B	MuRata ⁽⁵⁾	1µF/25V, ceramic cap	3
	VJ0805S105KXJAT	Vishay Victramon ⁽¹⁾		
C8	VJ0603Y101KXAMT	Vishay Vitramon ⁽¹⁾	100pF, 50V, X7R ceramic cap	1
LED	LEW E3A	OSRAM ⁽⁷⁾	OPEN	0
R1, R17	CRCW06031002FRT1	Vishay Dale ⁽¹⁾	10K, 0603, 1%	2
R2	CRCW08051501FRT1	Vishay Dale ⁽¹⁾	1.5K, 0805, 1%	1

Item	Part Number	Manufacturer	Description	Qty.
R3	CRCW06032431FRT1	Vishay Dale ⁽¹⁾	2.43K, 0603, 1%.	1
R4	CRCW06031000FRT1	Vishay Dale ⁽¹⁾	100 Ohm , 0603, 1%	1
R6	CRCW06031821FRT1	Vishay Dale ⁽¹⁾	1.82K, 0603, 1%	1
R7	CRCW06032200FRT1	Vishay Dale ⁽¹⁾	220Ω, 0603, 1%.	1
R8	WSL1210-R010-F	Vishay Dale ⁽¹⁾	10mΩ, 1210	1
	WSL2010-R010-F			
R9	CRCW08055R11FRT1	Vishay Dale ⁽¹⁾	5.11Ω, 0805, 1%.	1
R10	WSL1210-R330-F	Vishay Dale ⁽¹⁾	330mΩ, 1210, 1%.	1
	WSL2010-R330-F			
R11	CRCW08052742FRT1	Vishay Dale ⁽¹⁾	27.4K, 0805, 1%	1
R14	CRCW06031502FRT1	Vishay Dale ⁽¹⁾	15K, 0603, 1%	1
R15	CRCW06031003FRT1	Vishay Dale ⁽¹⁾	100K, 0603, 1%	1
R16	CRCW06031961FRT1	Vishay Dale ⁽¹⁾	1.96K, 0603, 1%	1
Z2	LM4041CYM3-ADJ	Micrel, Inc.⁽⁸⁾	Precision shunt Voltage references	1
IC1	MIC2196YM	Micrel, Inc.⁽⁸⁾	Boost controller	1

Notes:

1. Vishay: www.vishay.com
2. Fairchild Semiconductor: www.fairchildsemi.com
3. Diodes, Inc.: www.diodes.com
4. Sumida: www.sumida.com
5. Murata: www.murata.com
6. TDK: www.tdk.com
7. Osram: osram.com
8. **Micrel, Inc.:** www.micrel.com

PCB Layout

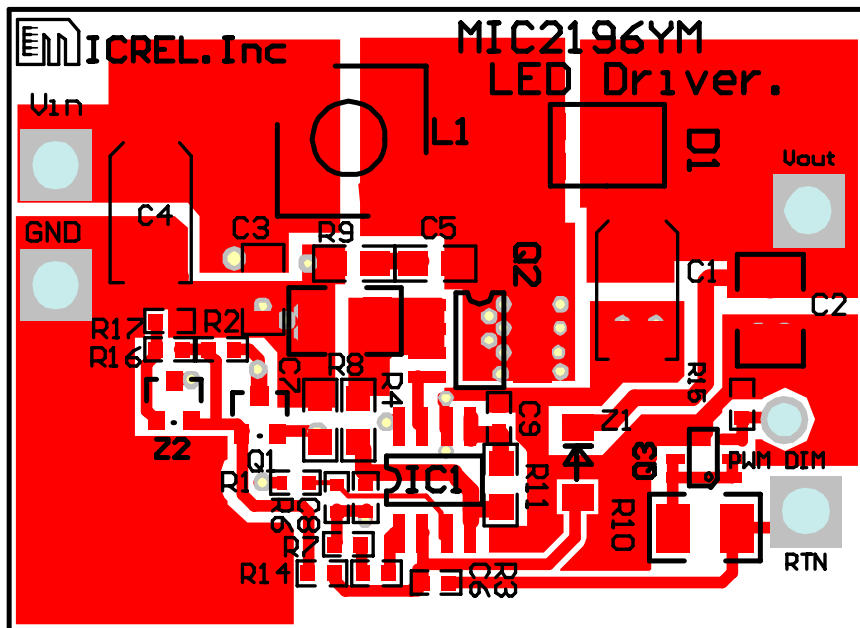

Top Layer

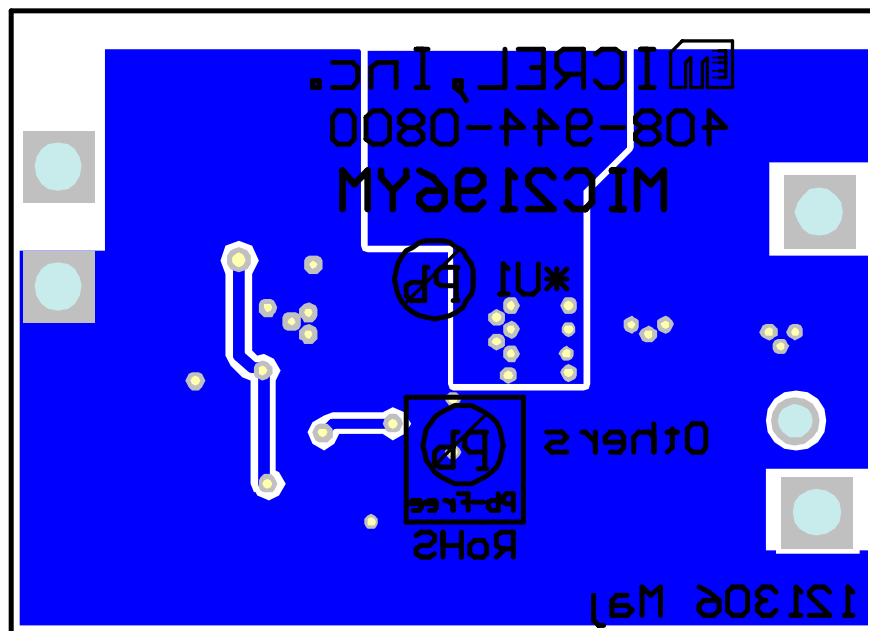

Bottom Layer

MICREL, INC. 2180 FORTUNE DRIVE SAN JOSE, CA 95131 USA
TEL +1 (408) 944-0800 FAX +1 (408) 474-1000 WEB <http://www.micrel.com>

The information furnished by Micrel in this data sheet is believed to be accurate and reliable. However, no responsibility is assumed by Micrel for its use. Micrel reserves the right to change circuitry and specifications at any time without notification to the customer.

Micrel Products are not designed or authorized for use as components in life support appliances, devices or systems where malfunction of a product can reasonably be expected to result in personal injury. Life support devices or systems are devices or systems that (a) are intended for surgical implant into the body or (b) support or sustain life, and whose failure to perform can be reasonably expected to result in a significant injury to the user. A Purchaser's use or sale of Micrel Products for use in life support appliances, devices or systems is a Purchaser's own risk and Purchaser agrees to fully indemnify Micrel for any damages resulting from such use or sale.

© 2007 Micrel, Incorporated.



Компания «ЭлектроПласт» предлагает заключение долгосрочных отношений при поставках импортных электронных компонентов на взаимовыгодных условиях!

Наши преимущества:

- Оперативные поставки широкого спектра электронных компонентов отечественного и импортного производства напрямую от производителей и с крупнейших мировых складов;
- Поставка более 17-ти миллионов наименований электронных компонентов;
- Поставка сложных, дефицитных, либо снятых с производства позиций;
- Оперативные сроки поставки под заказ (от 5 рабочих дней);
- Экспресс доставка в любую точку России;
- Техническая поддержка проекта, помощь в подборе аналогов, поставка прототипов;
- Система менеджмента качества сертифицирована по Международному стандарту ISO 9001;
- Лицензия ФСБ на осуществление работ с использованием сведений, составляющих государственную тайну;
- Поставка специализированных компонентов (Xilinx, Altera, Analog Devices, Intersil, Interpoint, Microsemi, Aeroflex, Peregrine, Syfer, Eurofarad, Texas Instrument, Miteq, Cobham, E2V, MA-COM, Hittite, Mini-Circuits, General Dynamics и др.);

Помимо этого, одним из направлений компании «ЭлектроПласт» является направление «Источники питания». Мы предлагаем Вам помощь Конструкторского отдела:

- Подбор оптимального решения, техническое обоснование при выборе компонента;
- Подбор аналогов;
- Консультации по применению компонента;
- Поставка образцов и прототипов;
- Техническая поддержка проекта;
- Защита от снятия компонента с производства.



Как с нами связаться

Телефон: 8 (812) 309 58 32 (многоканальный)

Факс: 8 (812) 320-02-42

Электронная почта: org@eplast1.ru

Адрес: 198099, г. Санкт-Петербург, ул. Калинина, дом 2, корпус 4, литера А.