



# TAOGLAS®



# Datasheet

## Cyclone

**Part No:**  
*FXUB64.18.0150A*

### Description:

LTE Wide Band Flex Antenna 600MHz–3000MHz

### Features:

- 600-3000 MHz Wide Band Antenna
- LTE Band 71 Support
- >45% Efficiency on All bands & 6 dBi Peak Gain
- Flexible “Peel and Stick” PCB Antenna
- 130\*30\*0.2 mm size
- Connector: Hirose (U. FL Compatible)
- Cable: 150mm 1.13mm coax
- RoHS & Reach Compliant

1. Introduction	3
2. Specifications	4
3. Antenna Characteristics	6
4. 2D Radiation Patterns	8
5. 3D Radiation Patterns	11
6. Mechanical Drawing	15
7. Application Note	16
8. Packaging	17
<hr/>	
Changelog	18

Taoglas makes no warranties based on the accuracy or completeness of the contents of this document and reserves the right to make changes to specifications and product descriptions at any time without notice. Taoglas reserves all rights to this document and the information contained herein.

Reproduction, use or disclosure to third parties without express permission is strictly prohibited.



# 1. Introduction



The Taoglas patent pending FXUB64.18.0150A flexible wideband antenna has been designed to cover all working frequencies in the 600-3000 MHz spectrum, covering all Cellular, 2.4GHz Wi-Fi, ISM, NB-IoT, CAT-M1 and AGPS, including LTE band 71. The antenna is delivered with a flexible body with excellent efficiencies on all bands, ground independent, with cable and connector for easy installation.

Typical Applications Include:

- Remote Monitoring
- POS (Point of Sales) Systems
- In-Building Communications Continuity

The FXUB64 flexible polymer antenna, at 130\*30\*0.2mm, is ultra-thin and truly wideband with high efficiencies across the bands. It is assembled by a simple “peel and stick” process, attaching securely to non-metal surfaces via 3M adhesive. It enables designers to use only one antenna that covers all common LTE frequencies.

The FXUB64 antenna is a durable flexible polymer antenna that has a peak gain of 6 dBi, an efficiency of more than 50% across the bands and is designed to be mounted directly onto a plastic or glass cover. It is an ideal choice for any device maker that needs to keep manufacturing costs down over the lifetime of a product. It is ground plane independent and delivered with a cable and connector for easy connecting to the wireless module or customer PCB.

Cables and Connectors are customizable. Like all such antennas, care should be taken to mount the antenna at least 10mm from metal components or surfaces, and ideally 20mm for best radiation efficiency.

For more information or support with integrating this antenna into your device. please contact your regional Taoglas customer support team.

## 2. Specifications

Electrical						
Frequency (MHz)	617-960	1575.42	1710-1990	1755-2170	2400-2500	2500-2690
Return Loss (dB)						
1.5mm ABS	< -4	< -7	< -10	< -10	< -5	< -4
Peak Gain (dBi)						
1.5mm ABS	3.5	4.5	6.0	6.0	3.7	2.3
Average Gain (dB)						
1.5mm ABS	-3.0	-2.3	-1.5	-1.7	-2.5	-3.3
Efficiency (%)						
1.5mm ABS	50	59	70	68	57	47
Impedance	50Ω					
Polarization	Linear					
Radiation Pattern	Omni					
Input Power	50 W					
Mechanical						
Dimensions (mm)	130*30*0.2 mm					
Material	Flexible Polymer					
Weight	2.4 g					
Connector	Hirose U.FL					
Cable	1.13 mm mini coax					
Cable Length	150 mm					
Environmental						
Operation Temperature	-40°C to 85°C					
Storage Temperature	-40°C to 85°C					
Relative Humidity	40% to 95%					
RoHs Compliant	Yes					
REACH Compliant	Yes					

5G/4G Bands			
Band Number	5G NR / FR1 / LTE / LTE-Advanced / WCDMA / HSPA / HSPA+ / TD-SCDMA		
	Uplink	Downlink	Covered
1	UL: 1920 to 1980	DL: 2110 to 2170	✓
2	UL: 1850 to 1910	DL: 1930 to 1990	✓
3	UL: 1710 to 1785	DL: 1805 to 1880	✓
4	UL: 1710 to 1755	DL: 2110 to 2155	✓
5	UL: 824 to 849	DL: 869 to 894	✓
7	UL: 2500 to 2570	DL: 2620 to 2690	✓
8	UL: 880 to 915	DL: 925 to 960	✓
9	UL: 1749.9 to 1784.9	DL: 1844.9 to 1879.9	✓
11	UL: 1427.9 to 1447.9	DL: 1475.9 to 1495.9	✓
12	UL: 699 to 716	DL: 729 to 746	✓
13	UL: 777 to 787	DL: 746 to 756	✓
14	UL: 788 to 798	DL: 758 to 768	✓
17	UL: 704 to 716	DL: 734 to 746	✓
18	UL: 815 to 830	DL: 860 to 875	✓
19	UL: 830 to 845	DL: 875 to 890	✓
20	UL: 832 to 862	DL: 791 to 821	✓
21	UL: 1447.9 to 1462.9	DL: 1495.9 to 1510.9	✓
22	UL: 3410 to 3490	DL: 3510 to 3590	✗
23	UL: 2000 to 2020	DL: 2180 to 2200	✓
24	UL: 1625.5 to 1660.5	DL: 1525 to 1559	✓
25	UL: 1850 to 1915	DL: 1930 to 1995	✓
26	UL: 814 to 849	DL: 859 to 894	✓
27	UL: 807 to 824	DL: 852 to 869	✓
28	UL: 703 to 748	DL: 758 to 803	✓
29	UL: -	DL: 717 to 728	✓
30	UL: 2305 to 2315	DL: 2350 to 2360	✓
31	UL: 452.5 to 457.5	DL: 462.5 to 467.5	✗
32	UL: -	DL: 1452 - 1496	✓
35		1850 to 1910	✓
38		2570 to 2620	✓
39		1880 to 1920	✓
40		2300 to 2400	✓
41		2496 to 2690	✓
42		3400 to 3600	✗
43		3600 to 3800	✗
48		3550 to 3700	✗
66	UL: 1710-1780	DL: 2110-2200	✓
71		617 to 698	✓
74/75/76		1427 to 1518	✓
77		3300 to 4200	✗
78		3300 to 3800	✗
79		4400 to 5000	✗

\* Covered Bands represent at least 20% efficiency

### 3. Antenna Characteristics

#### 3.1 Return Loss

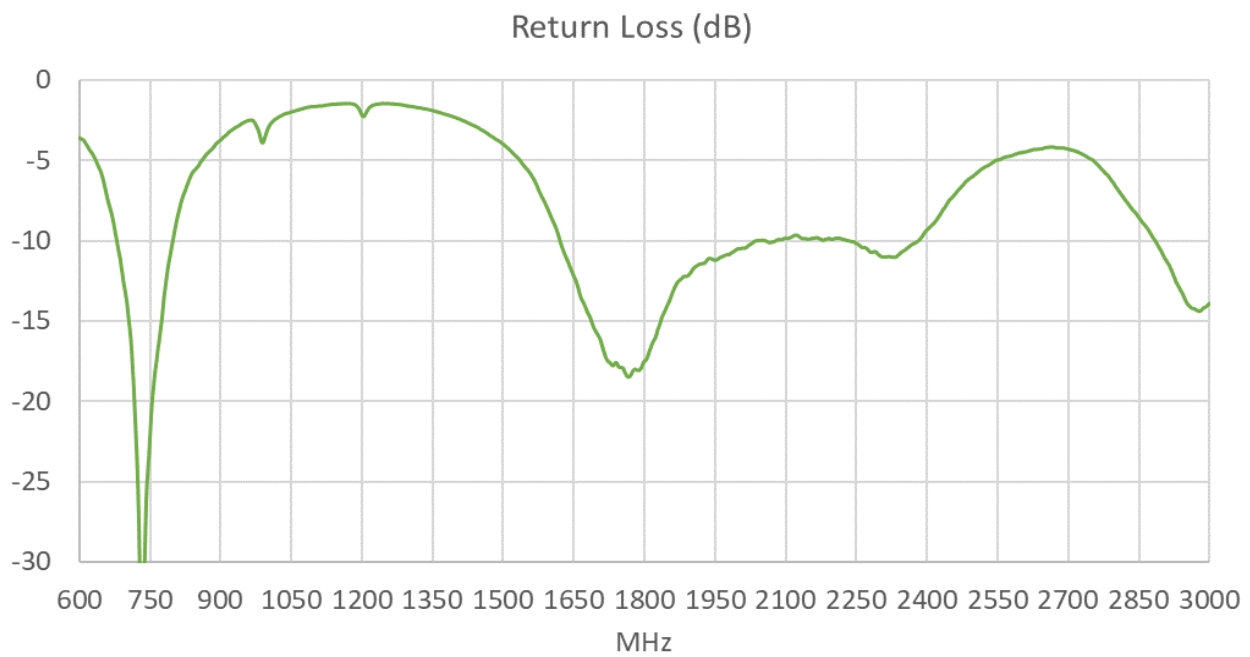

#### 3.2 Efficiency

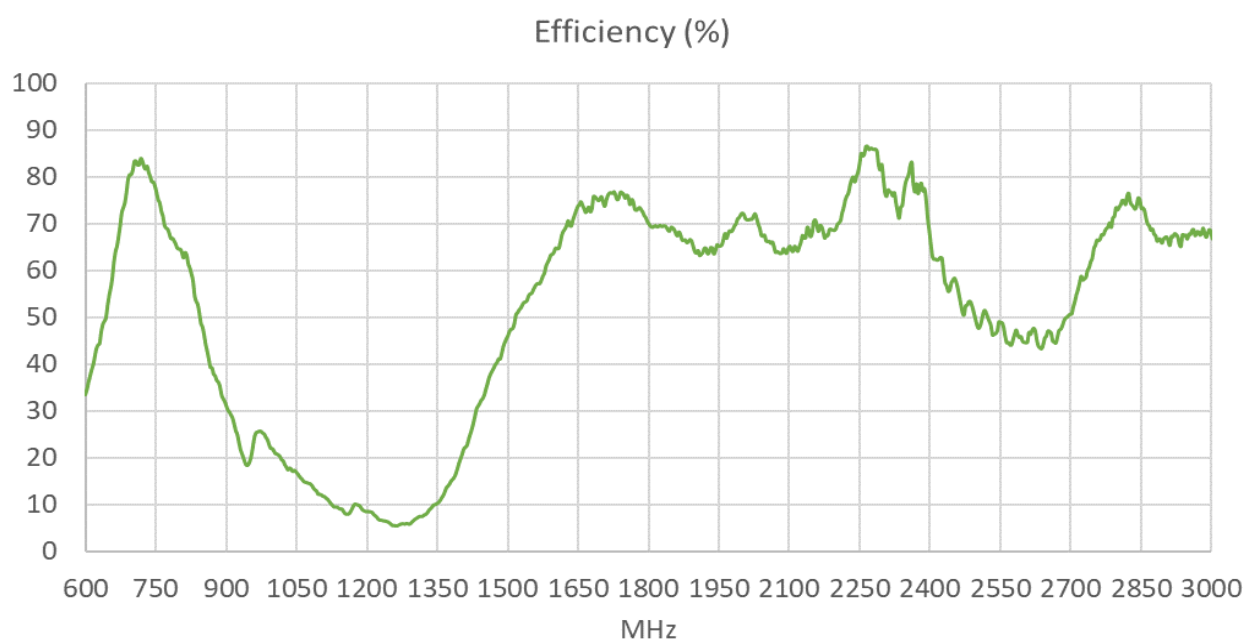

### 3.3 Average Gain

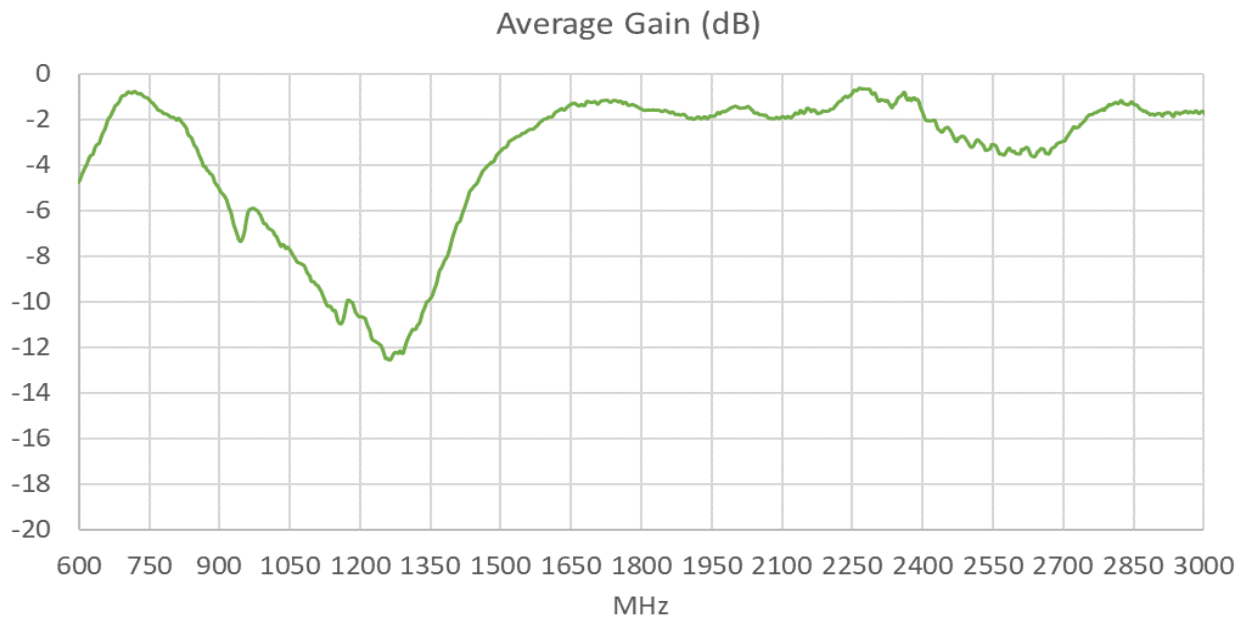

### 3.4 Peak Gain

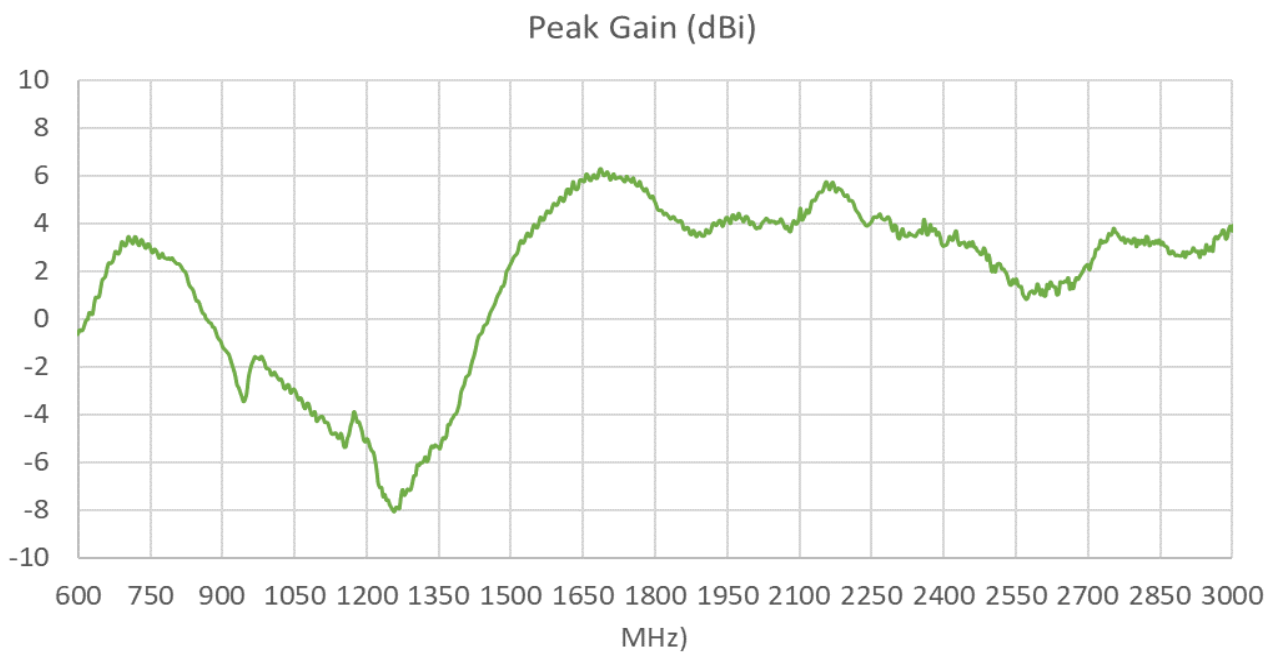

## 4. 2D Radiation Patterns

### 4.1 Test Setup

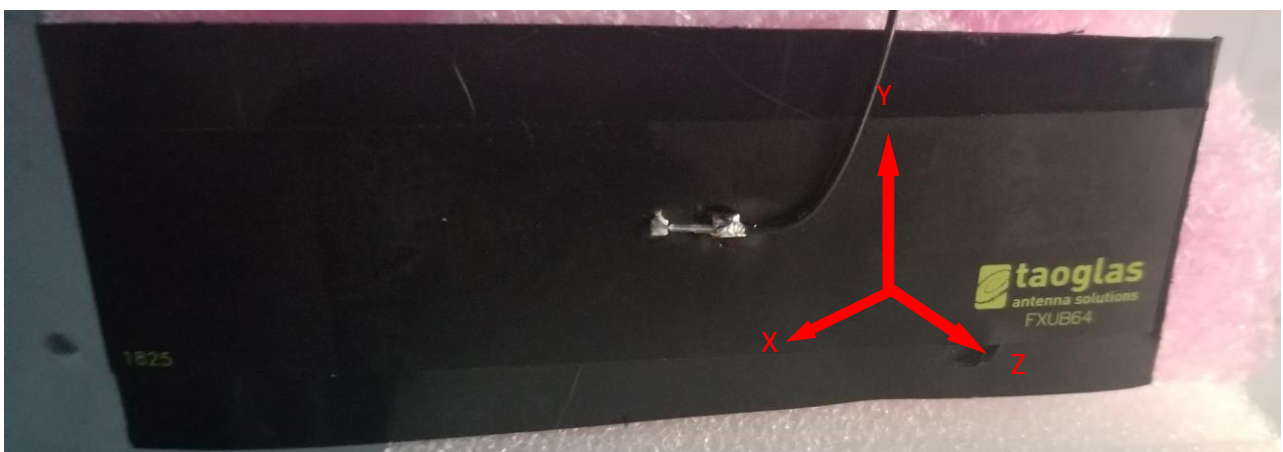
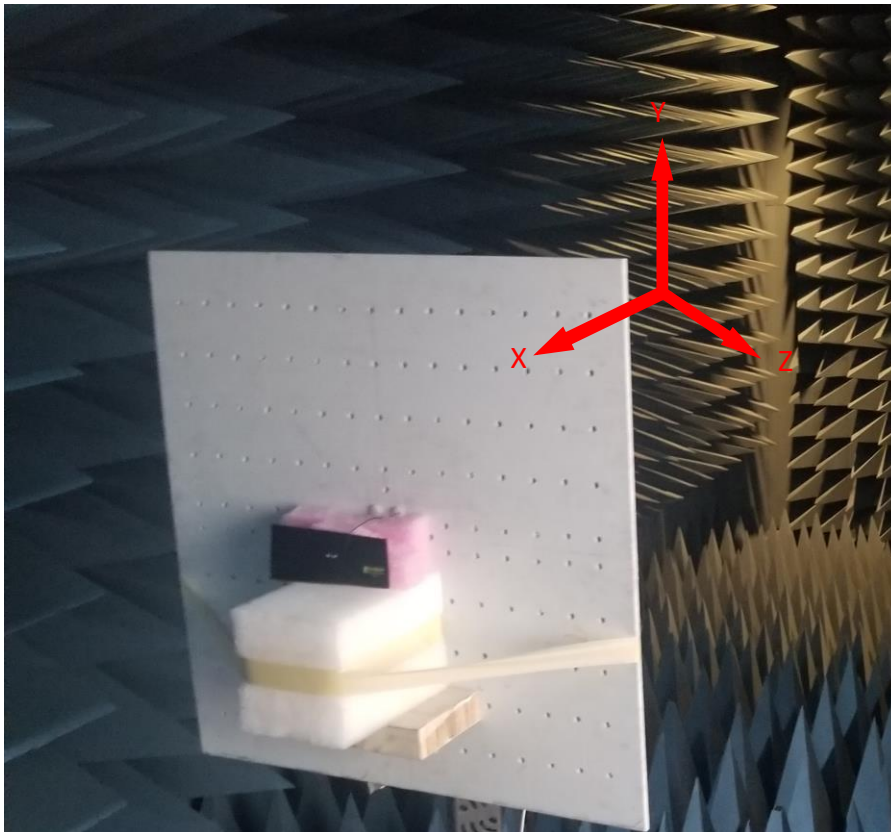



## XY Plane

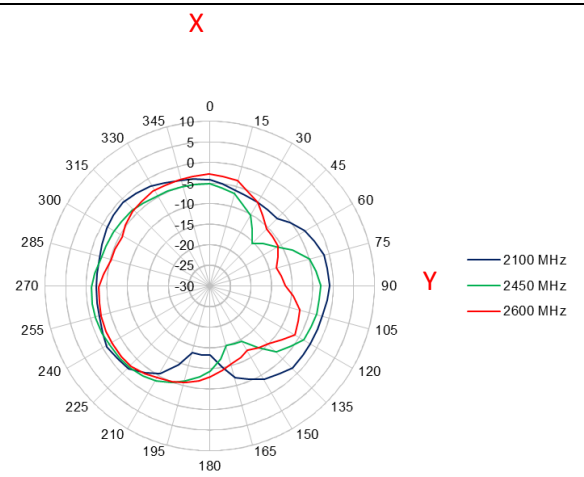
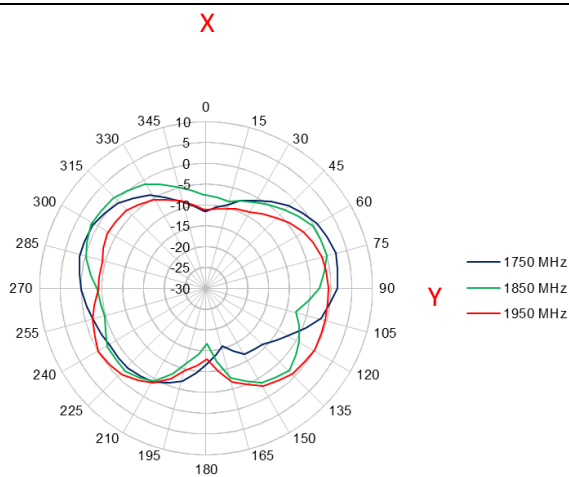
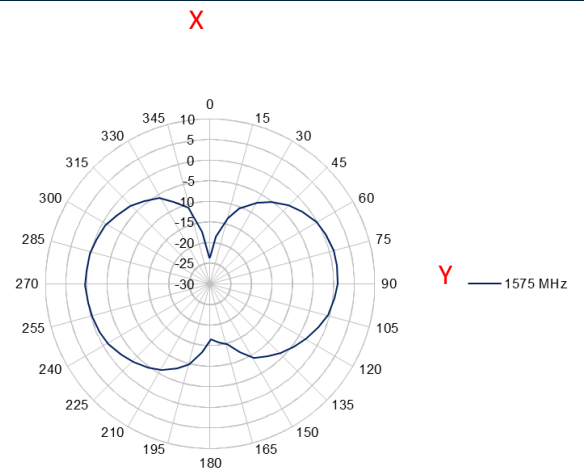
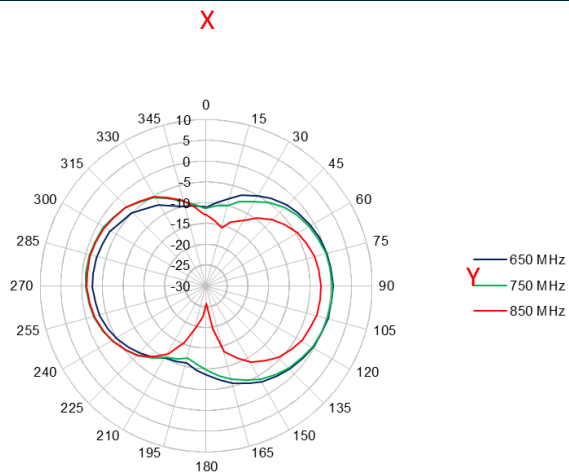

## XZ Plane

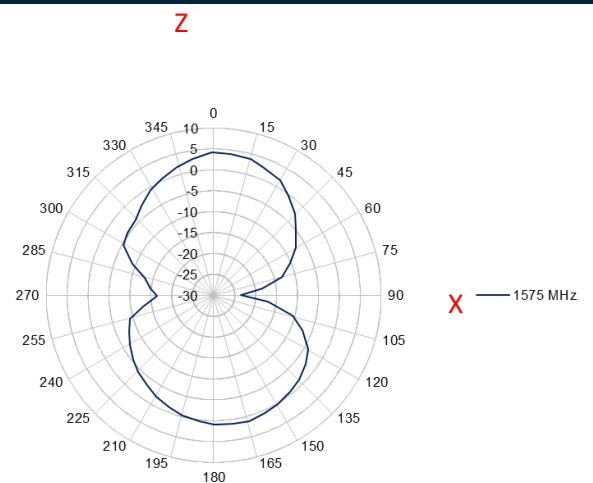
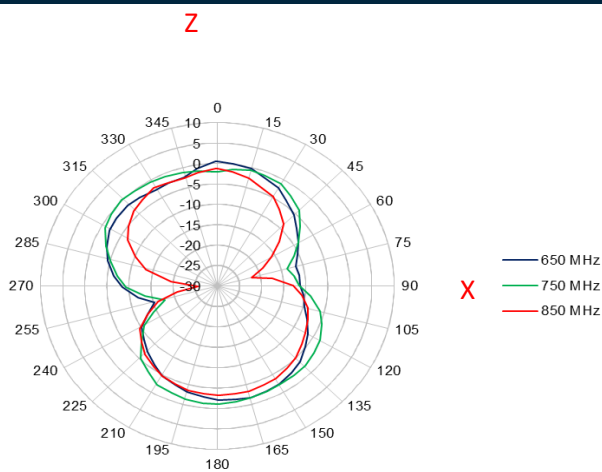

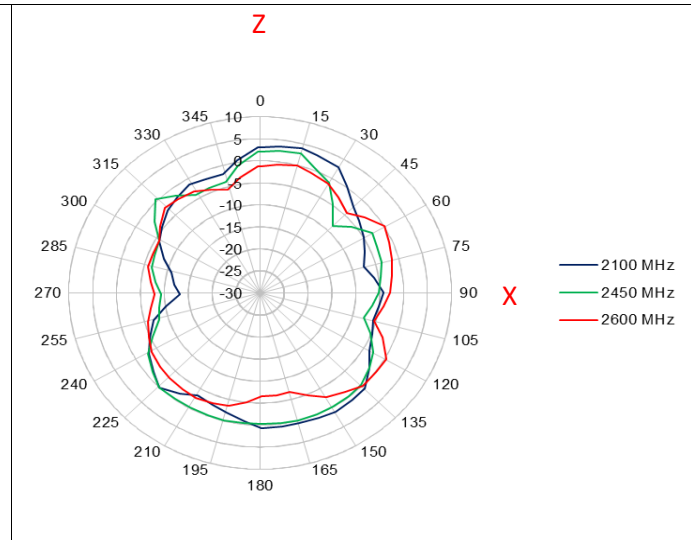
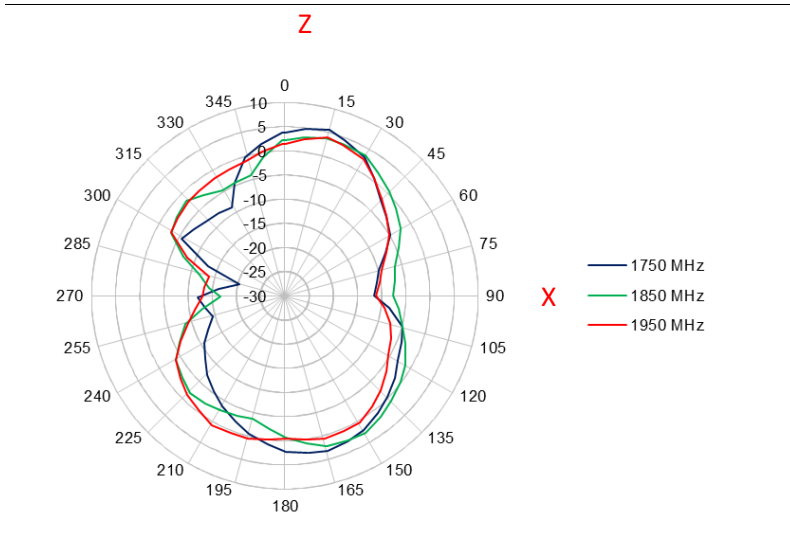

**YZ Plane**

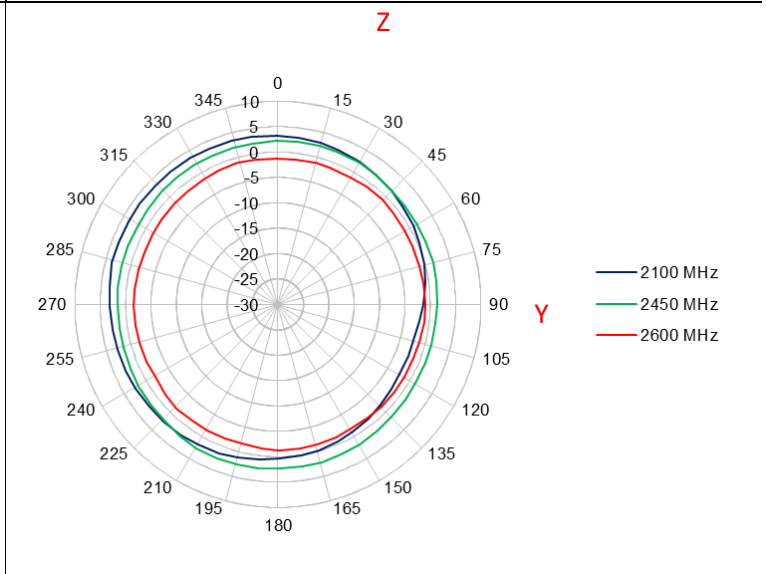
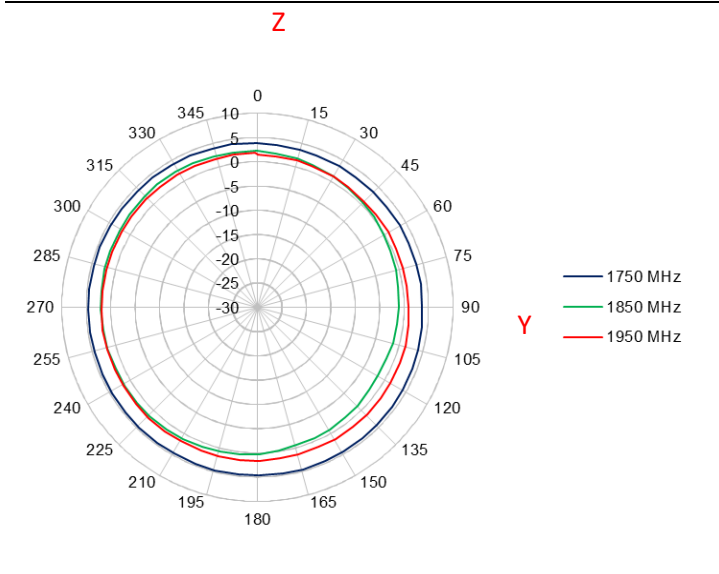
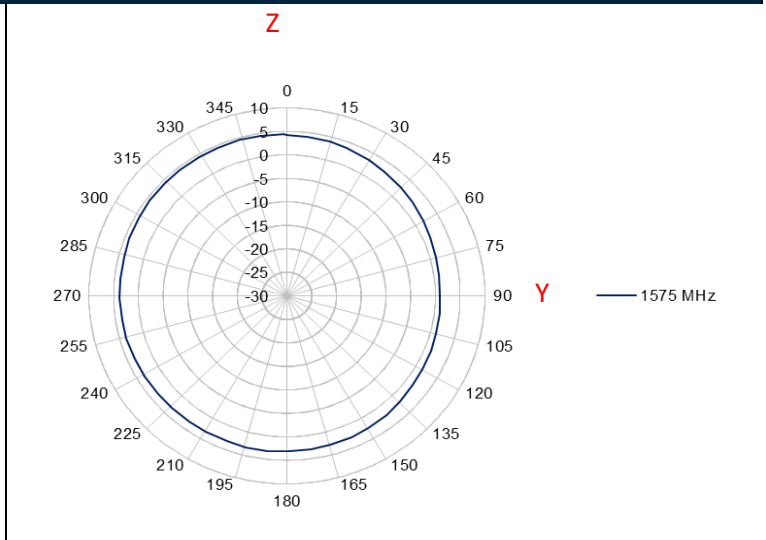
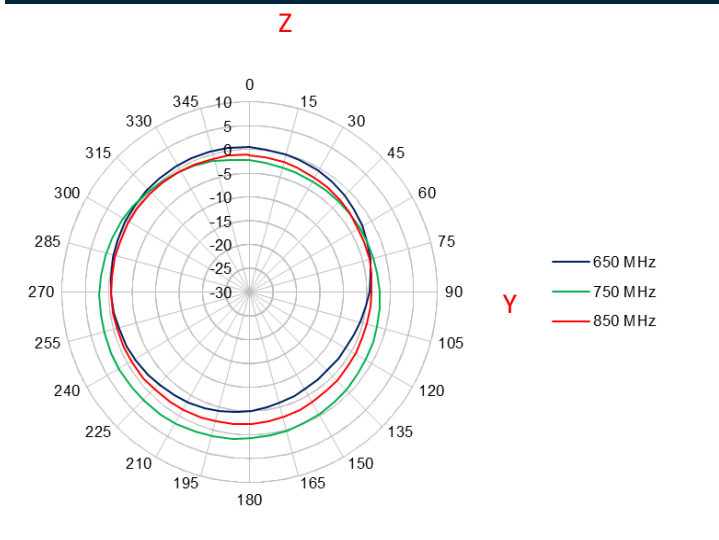

# 5. 3D Radiation Patterns

## 5.1 Free Space

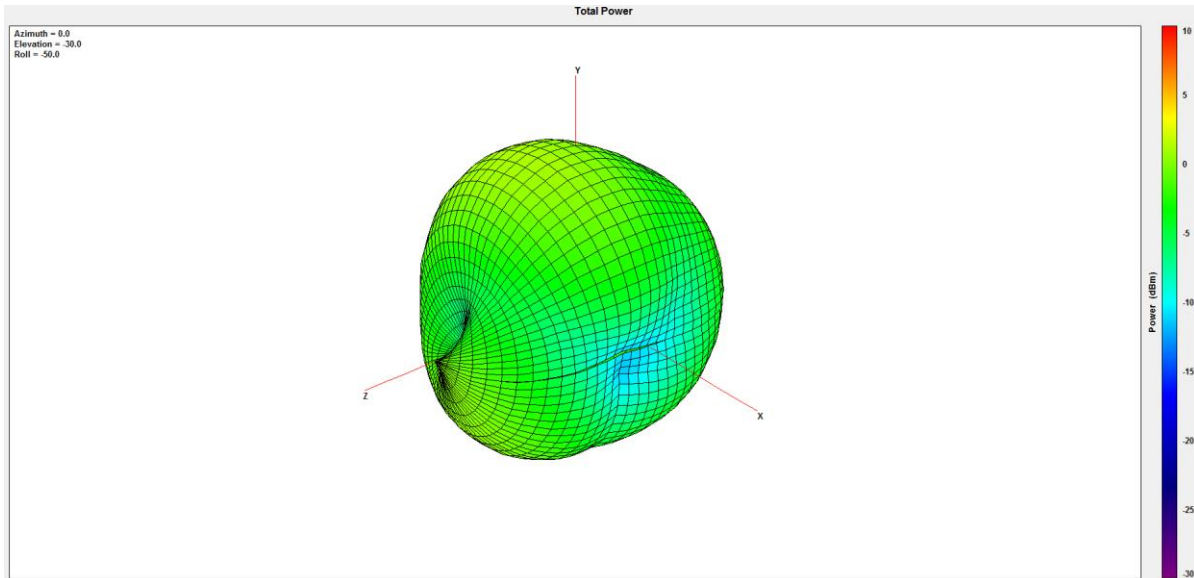

650MHz

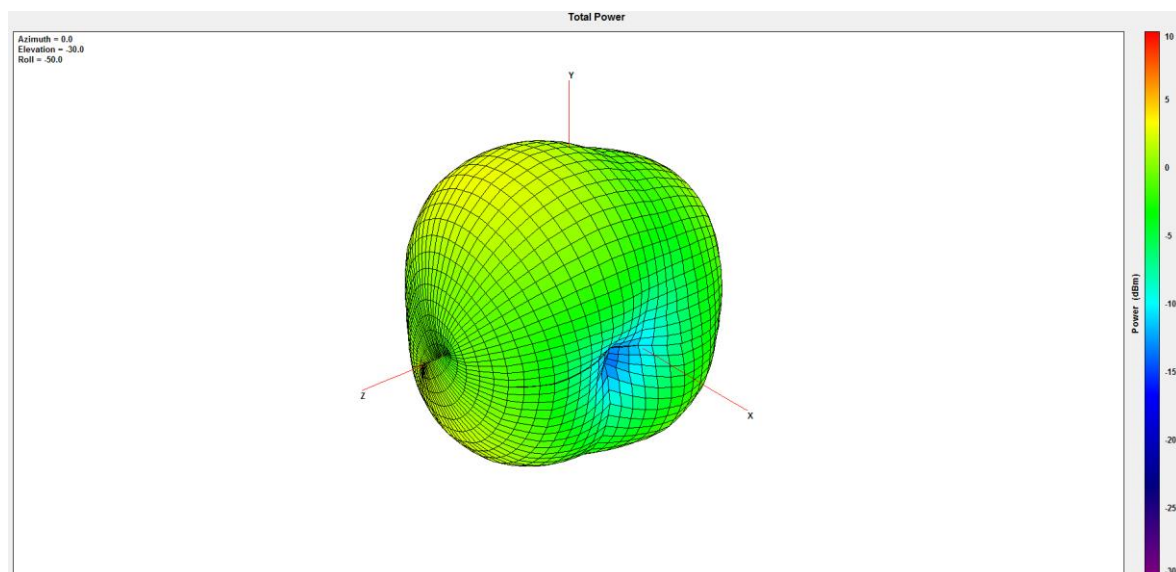

750MHz

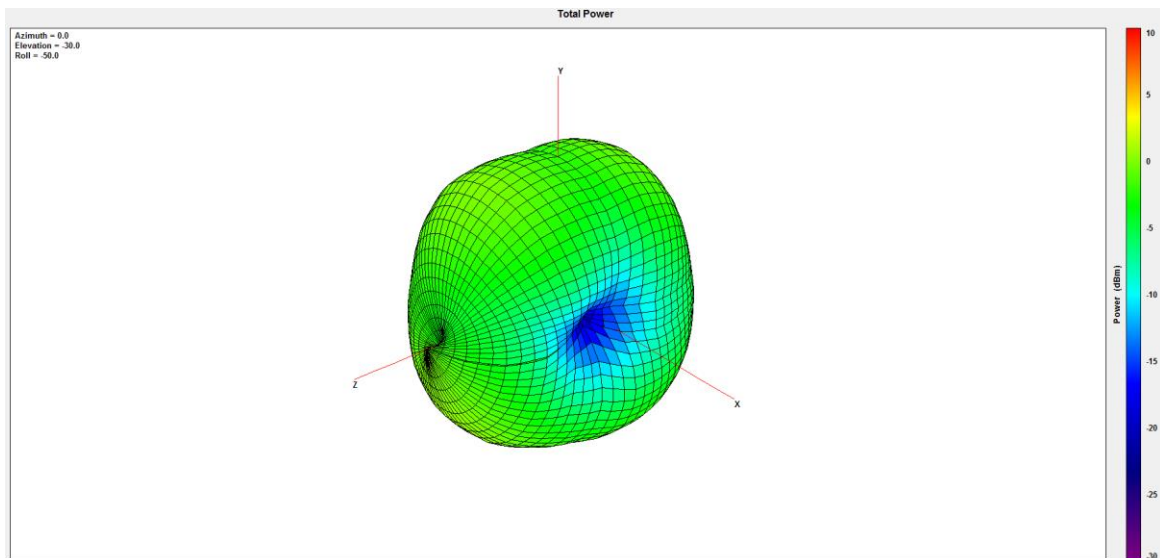

850MHz

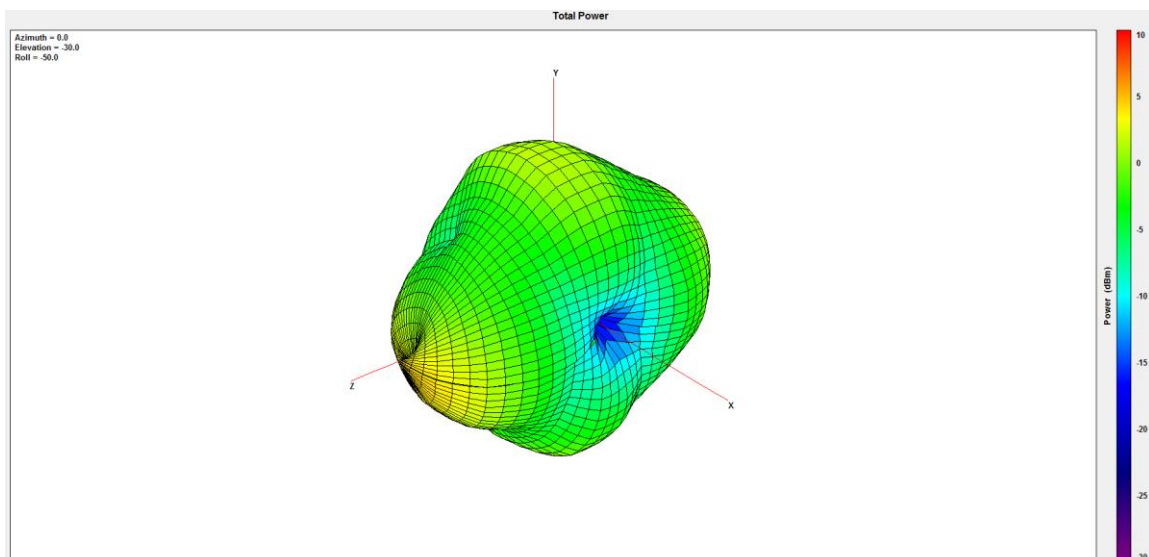

1575MHz

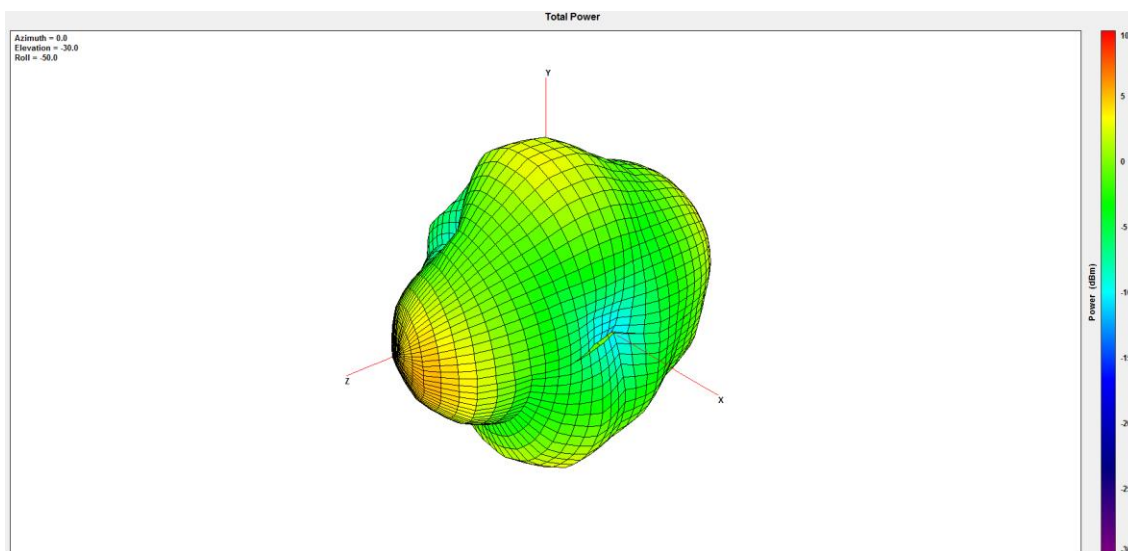

1750MHz

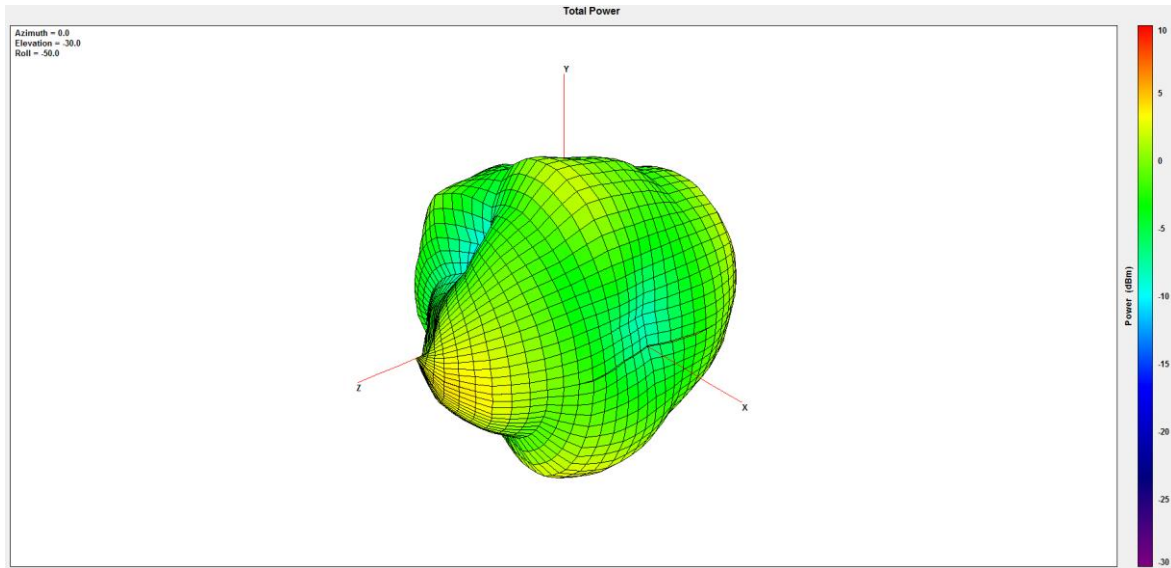

1850MHz

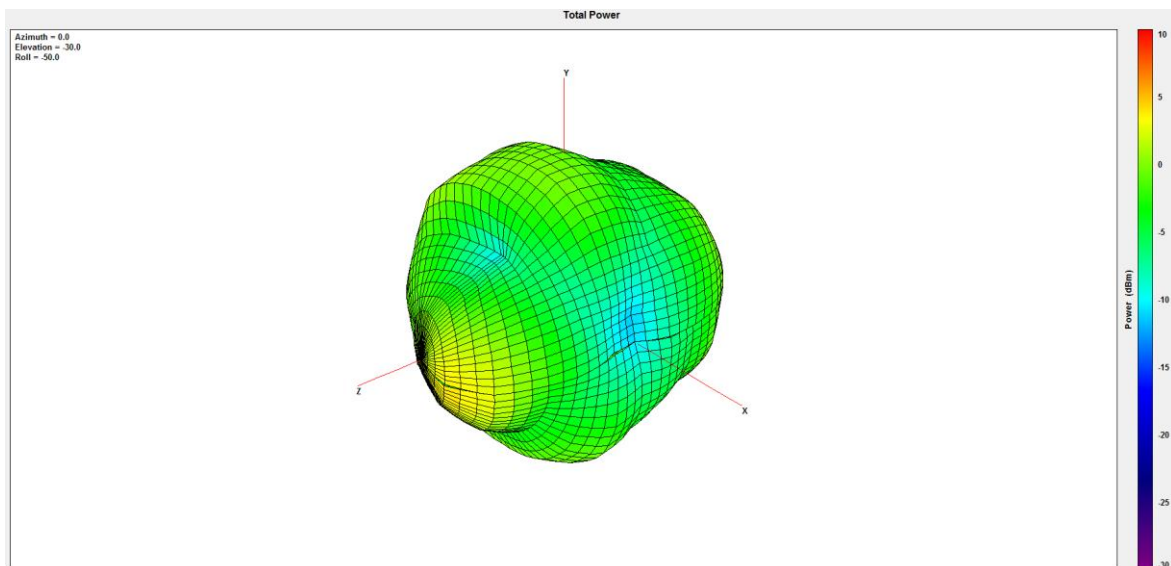

1950MHz

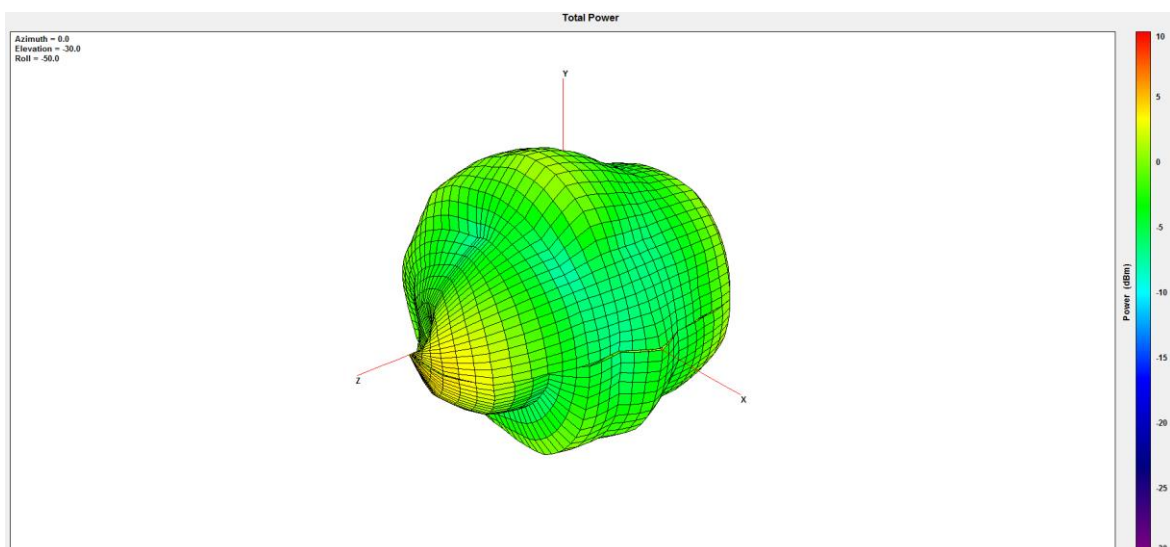

2100MHz

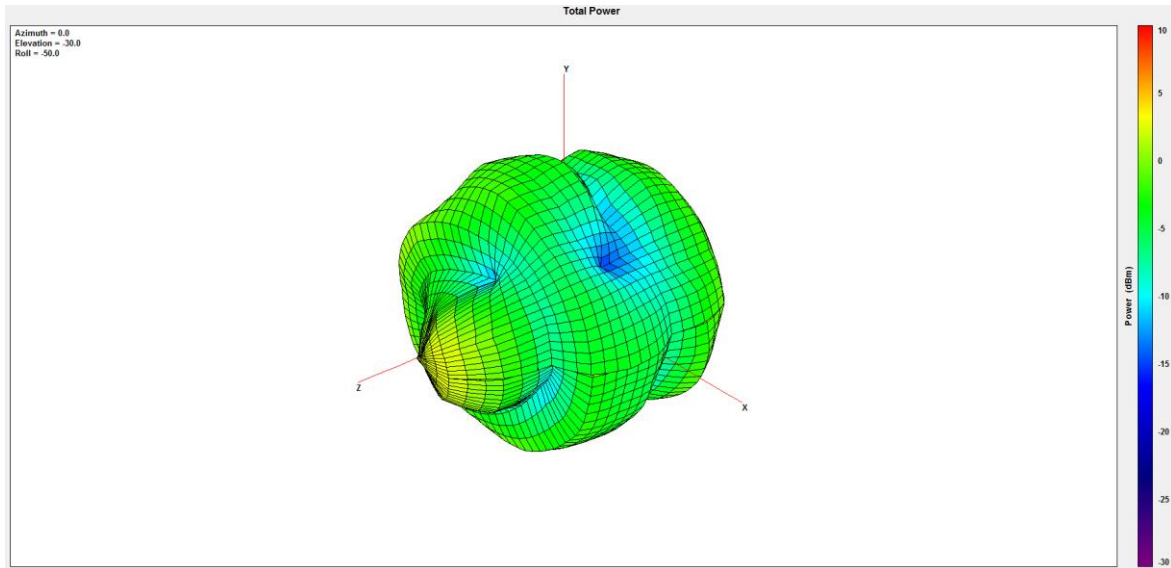

2450MHz

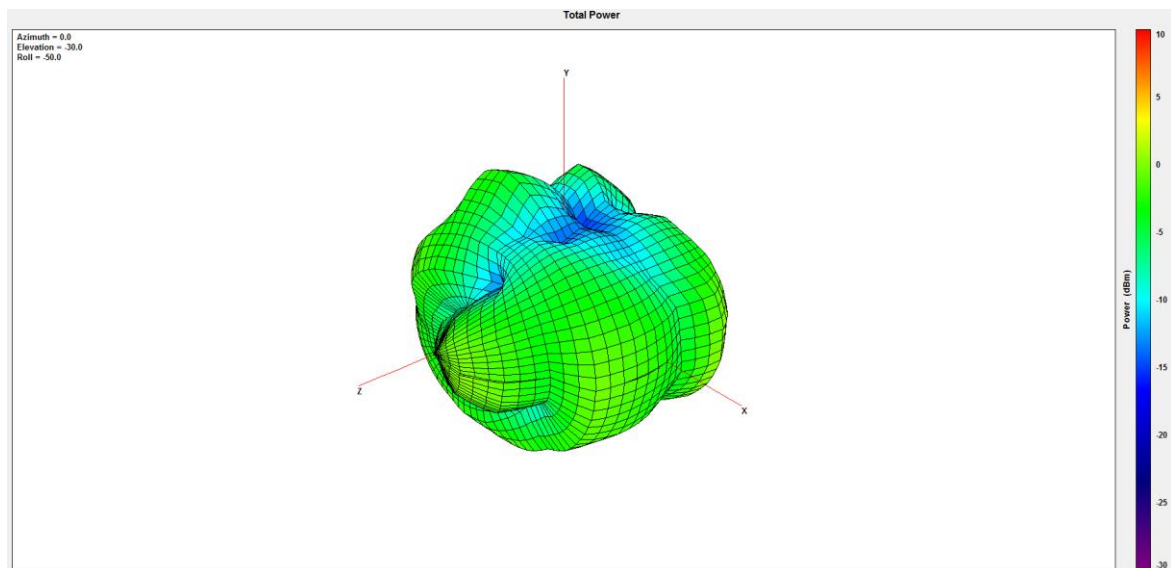

2600MHz

# 6. Mechanical Drawing (Units: mm)

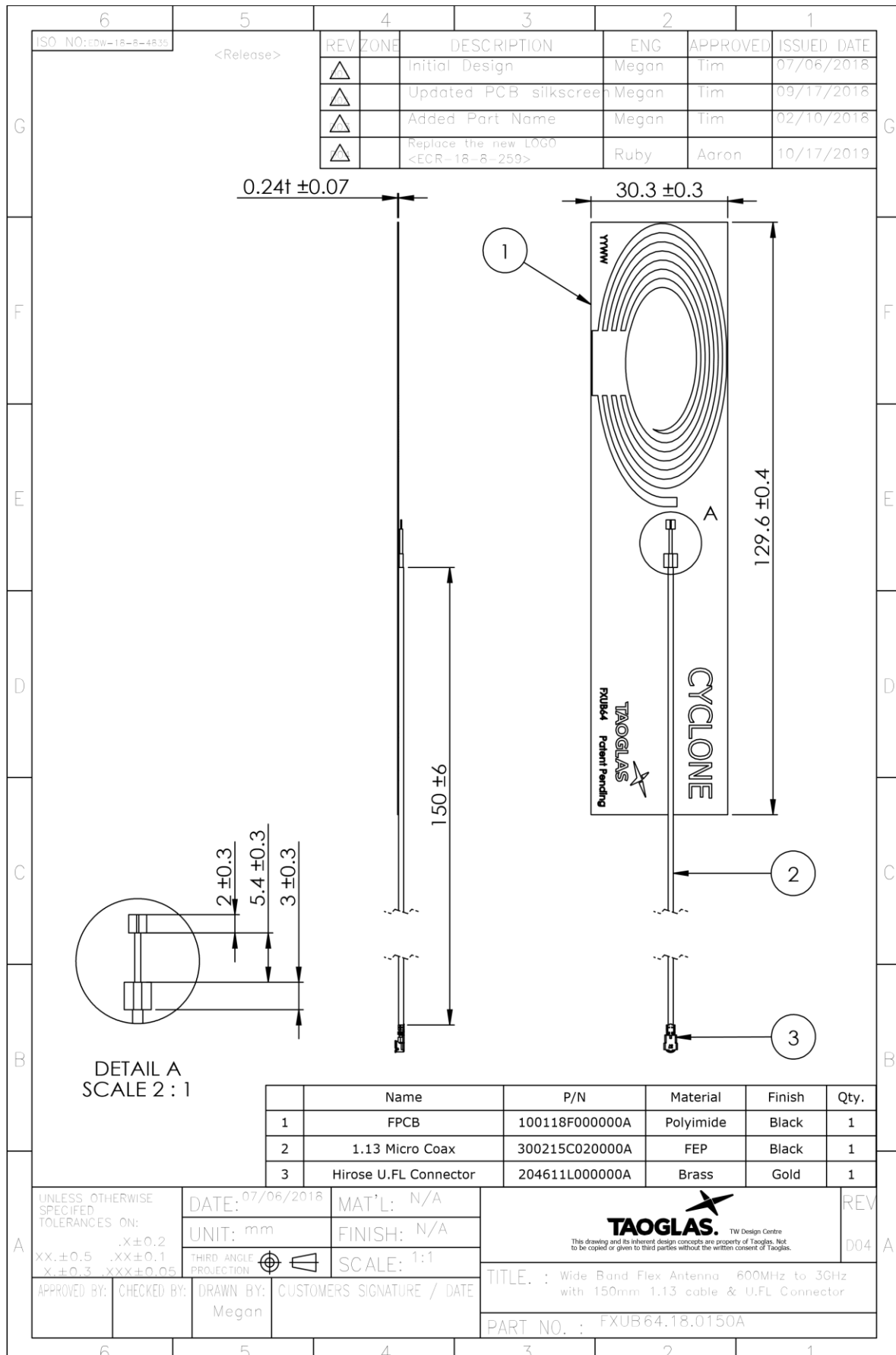

## 7. Application Note

Like all electrically small antennas, the cable on the FXUB64 provides a substantial portion of the low frequency radiation. Because of this, there are some cable routing configurations that provide higher performance than others. The cable routing configurations are listed from highest to least performance below:





## 8. Packaging

10pcs FXUB64.18.0150A per PE Bag  
 Dimensions – 304\*127mm  
 Weight - 100g

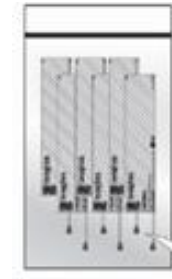

127mm

304mm

1000pcs FXUB64.18.0150A per carton  
 Dimensions - 405\*385\*295mm  
 Weight – 10.2Kg

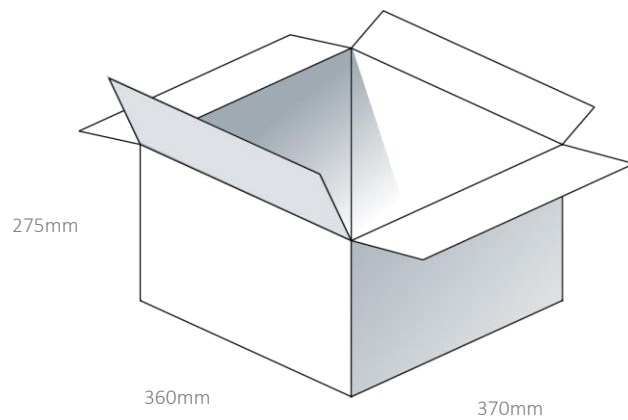

Changelog for the datasheet

**SPE-18-8-103 – FXUB64.18.0150A**

<b>Revision: C (Current Version)</b>	
Date:	2019-04-25
Changes:	Updated
Changes Made by:	Jack Conroy

**Previous Revisions**

<b>Revision: B</b>	
Date:	2019-04-25
Changes:	Packaging Details Updated
Changes Made by:	Jack Conroy

<b>Revision: A (Original First Release)</b>	
Date:	2018-09-11
Notes:	
Author:	Jack Conroy



**TAOGLAS**®

[www.taoglas.com](http://www.taoglas.com)





Компания «ЭлектроПласт» предлагает заключение долгосрочных отношений при поставках импортных электронных компонентов на взаимовыгодных условиях!

Наши преимущества:

- Оперативные поставки широкого спектра электронных компонентов отечественного и импортного производства напрямую от производителей и с крупнейших мировых складов;
- Поставка более 17-ти миллионов наименований электронных компонентов;
- Поставка сложных, дефицитных, либо снятых с производства позиций;
- Оперативные сроки поставки под заказ (от 5 рабочих дней);
- Экспресс доставка в любую точку России;
- Техническая поддержка проекта, помощь в подборе аналогов, поставка прототипов;
- Система менеджмента качества сертифицирована по Международному стандарту ISO 9001;
- Лицензия ФСБ на осуществление работ с использованием сведений, составляющих государственную тайну;
- Поставка специализированных компонентов (Xilinx, Altera, Analog Devices, Intersil, Interpoint, Microsemi, Aeroflex, Peregrine, Syfer, Eurofarad, Texas Instrument, Miteq, Cobham, E2V, MA-COM, Hittite, Mini-Circuits, General Dynamics и др.);

Помимо этого, одним из направлений компании «ЭлектроПласт» является направление «Источники питания». Мы предлагаем Вам помощь Конструкторского отдела:

- Подбор оптимального решения, техническое обоснование при выборе компонента;
- Подбор аналогов;
- Консультации по применению компонента;
- Поставка образцов и прототипов;
- Техническая поддержка проекта;
- Защита от снятия компонента с производства.



#### Как с нами связаться

**Телефон:** 8 (812) 309 58 32 (многоканальный)

**Факс:** 8 (812) 320-02-42

**Электронная почта:** [org@eplast1.ru](mailto:org@eplast1.ru)

**Адрес:** 198099, г. Санкт-Петербург, ул. Калинина, дом 2, корпус 4, литера А.