

AD7851

FEATURES

Single 5 V Supply
333 kSPS Throughput Rate/ ± 2 LSB DNL—A Grade
285 kSPS Throughput Rate/ ± 1 LSB DNL—K Grade
A and K Grades Guaranteed to 125°C/238 kSPS
Throughput Rate
Pseudo-Differential Input with Two Input Ranges
System and Self-Calibration with Autocalibration on
Power-Up
Read/Write Capability of Calibration Data
Low Power: 60 mW Typ
Power-Down Mode: 5 μ W Typ Power Consumption
Flexible Serial Interface: 8051/SPI[®]/QSPI[™]/ μ P Compatible
24-Lead PDIP, SOIC, and SSOP Packages

APPLICATIONS

Digital Signal Processing
Speech Recognition and Synthesis
Spectrum Analysis
DSP Servo Control
Instrumentation and Control Systems
High Speed Modems
Automotive

GENERAL DESCRIPTION

The AD7851 is a high speed, 14-bit ADC that operates from a single 5 V power supply. The ADC powers up with a set of default conditions at which time it can be operated as a read-only ADC. The ADC contains self-calibration and system calibration options to ensure accurate operation over time and temperature and has a number of power-down options for low power applications.

The AD7851 is capable of a 333 kHz throughput rate. The input track-and-hold acquires a signal in 0.33 μ s and features a pseudo-differential sampling scheme. The AD7851 has the added advantage of two input voltage ranges (0 V to V_{REF} and $-V_{REF}/2$ to $+V_{REF}/2$ centered about $V_{REF}/2$). Input signal range is to V_{DD} and the part is capable of converting full power signals to 20 MHz.

CMOS construction ensures low power dissipation (60 mW typ) with power-down mode (5 μ W typ). The part is available in a 24-lead, 0.3 inch-wide PDIP, a 24-lead SOIC, and a 24-lead SSOP package.

REV. B

Information furnished by Analog Devices is believed to be accurate and reliable. However, no responsibility is assumed by Analog Devices for its use, nor for any infringements of patents or other rights of third parties that may result from its use. No license is granted by implication or otherwise under any patent or patent rights of Analog Devices. Trademarks and registered trademarks are the property of their respective owners.

FUNCTIONAL BLOCK DIAGRAM

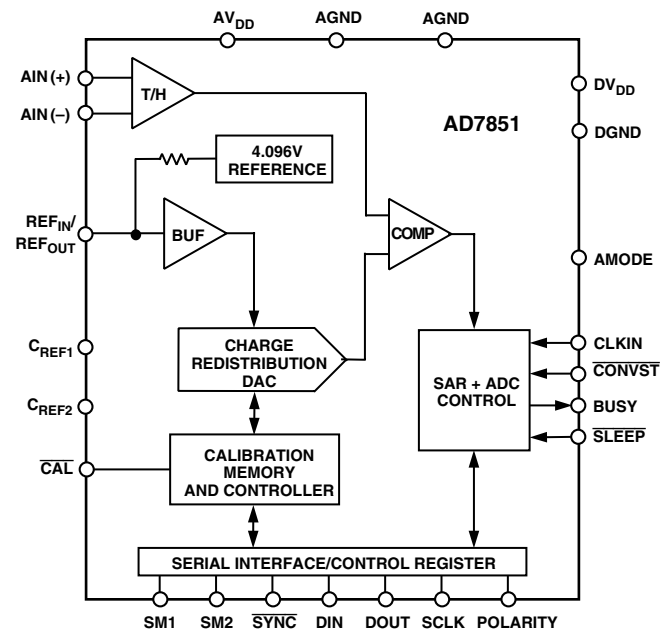

PRODUCT HIGHLIGHTS

1. Single 5 V supply.
2. Operates with reference voltages from 4 V to V_{DD} .
3. Analog input ranges from 0 V to V_{DD} .
4. System and self-calibration including power-down mode.
5. Versatile serial I/O port.

AD7851

TABLE OF CONTENTS

FEATURES	1	CALIBRATION SECTION	21
GENERAL DESCRIPTION	1	Calibration Overview	21
PRODUCT HIGHLIGHTS	1	Automatic Calibration on Power-On	21
SPECIFICATIONS	3	Self-Calibration Description	21
TIMING SPECIFICATIONS	5	Self-Calibration Timing	22
TYPICAL TIMING DIAGRAMS	6	System Calibration Description	22
ABSOLUTE MAXIMUM RATINGS	7	System Gain and Offset Interaction	23
ORDERING GUIDE	7	System Calibration Timing	23
PINOUTS	7	SERIAL INTERFACE SUMMARY	24
TERMINOLOGY	8	Resetting the Serial Interface	24
PIN FUNCTION DESCRIPTIONS	9	DETAILED TIMING	25
AD7851 ON-CHIP REGISTERS	10	Mode 1 (2-Wire 8051 Interface)	25
Addressing the On-Chip Registers	10	Mode 2 (3-Wire SPI/QSPI Interface Mode)	26
Writing/Reading	10	Mode 3 (QSPI Interface Mode)	26
CONTROL REGISTER	11	Mode 4 and 5 (Self-Clocking Modes)	27
STATUS REGISTER	12	CONFIGURING THE AD7851	28
CALIBRATION REGISTERS	13	AD7851 as a Read-Only ADC	28
Addressing the Calibration Registers	13	Writing to the AD7851	29
Writing to/Reading from the Calibration Registers	13	Interface Modes 2 and 3 Configuration	29
Adjusting the Offset Calibration Register	14	Interface Mode 1 Configuration	30
Adjusting the Gain Calibration Registers	14	Interface Modes 4 and 5 Configuration	30
CIRCUIT INFORMATION	15	MICROPROCESSOR INTERFACING	31
CONVERTER DETAILS	15	AD7851 to 8XC51/PIC17C42 Interface	31
TYPICAL CONNECTION DIAGRAM	15	AD7851 to 68HC11/16/L11/PIC16C42 Interface	31
ANALOG INPUT	16	AD7851 to ADSP-21xx Interface	32
Acquisition Time	16	AD7851 to DSP56000/1/2/L002 Interface	32
DC/AC Applications	16	AD7851 to TMS320C20/25/5x/LC5x Interface	32
Input Ranges	17	APPLICATIONS HINTS	33
Transfer Functions	17	Grounding and Layout	33
REFERENCE SECTION	18	Evaluating the AD7851 Performance	33
AD7851 PERFORMANCE CURVES	18	OUTLINE DIMENSIONS	34
POWER-DOWN OPTIONS	19	REVISION HISTORY	35
POWER-UP TIMES	20		
Using an External Reference	20		
Using the Internal (On-Chip) Reference	20		
POWER VS. THROUGHPUT RATE	20		

SPECIFICATIONS^{1, 2}

A Grade: $f_{CLKIN} = 7 \text{ MHz}$ (-40°C to $+85^{\circ}\text{C}$), $f_{SAMPLE} = 333 \text{ kHz}$; K Grade: $f_{CLKIN} = 6 \text{ MHz}$ (0°C to 85°C), $f_{SAMPLE} = 285 \text{ kHz}$; A and K Grade: $f_{CLKIN} = 5 \text{ MHz}$ (to 125°C), $f_{SAMPLE} = 238 \text{ kHz}$; ($AV_{DD} = DV_{DD} = 5.0 \text{ V} \pm 5\%$, $REF_{IN}/REF_{OUT} = 4.096 \text{ V}$ External Reference; SLEEP = Logic High; $T_A = T_{MIN}$ to T_{MAX} , unless otherwise noted.)

Parameter	Version A ¹	Version K ¹	Unit	Test Conditions/Comments
DYNAMIC PERFORMANCE				
Signal-to-Noise + Distortion Ratio ³ (SNR)	77	78	dB min	Typically SNR Is 79.5 dB.
Total Harmonic Distortion (THD)	-86	-86	dB max	$V_{IN} = 10 \text{ kHz}$, Sine Wave, $f_{SAMPLE} = 333 \text{ kHz}$.
Peak Harmonic or Spurious Noise Intermodulation Distortion (IMD)	-87	-87	dB max	$V_{IN} = 10 \text{ kHz}$, Sine Wave, $f_{SAMPLE} = 333 \text{ kHz}$, typically -96 dB.
Second-Order Terms	-86	-90	dB typ	$V_{IN} = 10 \text{ kHz}$, $f_{SAMPLE} = 333 \text{ kHz}$.
Third-Order Terms	-86	-90	dB typ	$f_a = 9.983 \text{ kHz}$, $f_b = 10.05 \text{ kHz}$, $f_{SAMPLE} = 333 \text{ kHz}$.
Full Power Bandwidth	20	20	MHz typ	$f_a = 9.983 \text{ kHz}$, $f_b = 10.05 \text{ kHz}$, $f_{SAMPLE} = 333 \text{ kHz}$. @ 3 dB.
DC ACCURACY				
Resolution	14	14	Bits	Guaranteed No Missed Codes to 14 Bits Review: Adjusting the Offset Calibration Register in the Calibration Registers section.
Integral Nonlinearity	± 2	± 1	LSB max	
Differential Nonlinearity	± 2	± 1	LSB max	
Unipolar Offset Error	± 10	± 10	LSB max	
Positive Full-Scale Error	± 10	± 10	LSB max	
Negative Full-Scale Error	± 10	± 10	LSB typ	
Bipolar Zero Error	± 1	± 1	LSB typ	
ANALOG INPUT				
Input Voltage Ranges	0 V to V_{REF}	0 V to V_{REF}	V	$A_{IN}(+) - A_{IN}(-) = 0 \text{ V}$ to V_{REF} , $A_{IN}(-)$ can be biased up but $A_{IN}(+)$ cannot go below $A_{IN}(-)$. $A_{IN}(+) - A_{IN}(-) = -V_{REF}/2$ to $+V_{REF}/2$, $A_{IN}(-)$ should be biased up and $A_{IN}(+)$ can go below $A_{IN}(-)$ but cannot go below 0 V.
	$\pm V_{REF}/2$	$\pm V_{REF}/2$	V	
Leakage Current	± 1	± 1	μA max	
Input Capacitance	20	20	pF typ	
REFERENCE INPUT/OUTPUT				
REF_{IN} Input Voltage Range	$4/V_{DD}$	$4/V_{DD}$	V min/max	Functional from 1.2 V. Resistor Connected to Internal Reference Node.
Input Impedance	150	150	k Ω typ	
REF_{OUT} Output Voltage	3.696/4.496	3.696/4.496	V min/max	
REF_{OUT} Temperature Coefficient	50	50	ppm/ $^{\circ}\text{C}$ typ	
LOGIC INPUTS				
Input High Voltage, V_{INH}	$V_{DD} - 1.0$	$V_{DD} - 1.0$	V min	$V_{IN} = 0 \text{ V}$ or V_{DD} .
Input Low Voltage, V_{INL}	0.4	0.4	V max	
Input Current, I_{IN}	± 10	± 10	μA max	
Input Capacitance, C_{IN}^4	10	10	pF max	
LOGIC OUTPUTS				
Output High Voltage, V_{OH}	$V_{DD} - 0.4$	$V_{DD} - 0.4$	V min	$I_{SOURCE} = 200 \mu\text{A}$. $I_{SINK} = 0.8 \text{ mA}$.
Output Low Voltage, V_{OL}	0.4	0.4	V max	
Floating State Leakage Current	± 10	± 10	μA max	
Floating State Output Capacitance ⁴	10	10	pF max	
Output Coding	Straight (Natural) Binary Twos Complement			Unipolar Input Range. Bipolar Input Range.
CONVERSION RATE				
Conversion Time	2.78	3.25	μs max	19.5 CLKIN Cycles.
Conversion + Track-and-Hold Acquisition Time	3.0	3.5	μs max	21 CLKIN Cycles Throughput Rate.

AD7851

Parameter	Version A ¹	Version K ¹	Unit	Test Conditions/Comments
POWER PERFORMANCE				
V_{DD}, DV_{DD}	4.75/5.25	4.75/5.25	V min/max	
I_{DD}				
Normal Mode ⁴	17	17	mA max	$V_{DD} = DV_{DD} = 4.75$ V to 5.25 V. Typically 12 mA.
Sleep Mode ⁵				
With External Clock On	20	20	μ A typ	Full Power-Down. Power management bits in control register set as PMGT1 = 1, PMGT0 = 0.
	600	600	μ A typ	Partial Power-Down. Power management bits in control register set as PMGT1 = 1, PMGT0 = 1.
With External Clock Off	10	10	μ A max	Typically 1 μ A. Full Power-Down. Power management bits in control register set as PMGT1 = 1, PMGT0 = 0.
	300	300	μ A typ	Partial Power-Down. Power management bits in control register set as PMGT1 = 1, PMGT0 = 1.
Normal Mode Power Dissipation	89.25	89.25	mW max	$V_{DD} = 5.25$ V; Typically 63 mW; $\overline{SLEEP} = V_{DD}$.
Sleep Mode Power Dissipation				
With External Clock On	105	105	μ W typ	$V_{DD} = 5.25$ V; $\overline{SLEEP} = 0$ V.
With External Clock Off	52.5	52.5	μ W max	$V_{DD} = 5.25$ V; Typically 5.25 μ W; $\overline{SLEEP} = 0$ V.
SYSTEM CALIBRATION				
Offset Calibration Span ⁶	$+0.05 \times V_{REF} / -0.05 \times V_{REF}$		V max/min	Allowable Offset Voltage Span for Calibration.
Gain Calibration Span ⁶	$+1.025 \times V_{REF} / -0.975 \times V_{REF}$		V max/min	Allowable Full-Scale Voltage Span for Calibration.

NOTES

¹Temperature ranges as follows: A Version, -40°C to $+125^{\circ}\text{C}$; K Version, 0°C to 125°C .

²Specifications apply after calibration.

³SNR calculation includes distortion and noise components.

⁴All digital inputs at DGND except for \overline{CONVST} , \overline{SLEEP} , \overline{CAL} , and \overline{SYNC} at DV_{DD} . No load on the digital outputs. Analog inputs at AGND.

⁵CLKIN at DGND when external clock off. All digital inputs at DGND except for \overline{CONVST} , \overline{SLEEP} , \overline{CAL} , and \overline{SYNC} at DV_{DD} . No load on the digital outputs. Analog inputs at AGND.

⁶The offset and gain calibration spans are defined as the range of offset and gain errors that the AD7851 can calibrate. Note also that these are voltage spans and are not absolute voltages (i.e., the allowable system offset voltage presented at AIN(+) for the system offset error to be adjusted out will be $A_{IN}(-) \pm 0.05 \times V_{REF}$, and the allowable system full-scale voltage applied between AIN(+) and AIN(-) for the system full-scale voltage error to be adjusted out will be $V_{REF} \pm 0.025 \times V_{REF}$). This is explained in more detail in the Calibration section of the data sheet.

Specifications subject to change without notice.

TIMING SPECIFICATIONS¹ ($A_{V_{DD}} = DV_{DD} = 5.0\text{ V} \pm 5\%$; $f_{CLKIN} = 6\text{ MHz}$, $T_A = T_{MIN}$ to T_{MAX} , unless otherwise noted.)

Descriptions that refer to SCLK \uparrow (rising) or SCLK \downarrow (falling) edges are with the POLARITY pin HIGH. For the POLARITY pin LOW, then the opposite edge of SCLK will apply.

Parameter	Limit at T_{MIN} , T_{MAX} (A, K Versions)	Unit	Description
f_{CLKIN}^2	500 7	kHz min MHz max	Master Clock Frequency
f_{SCLK}^3	10 f_{CLKIN}	MHz max MHz max	Interface Modes 1, 2, 3 (External Serial Clock) Interface Modes 4, 5 (Internal Serial Clock)
t_1^4	100	ns min	\overline{CONVST} Pulse Width
t_2	50	ns max	$\overline{CONVST}\downarrow$ to $BUSY\uparrow$ Propagation Delay
$t_{CONVERT}$	3.25	μs max	Conversion Time = $20 t_{CLKIN}$
t_3	$-0.4 t_{SCLK}$ $\pm 0.4 t_{SCLK}$	ns min ns min/max	$\overline{SYNC}\downarrow$ to SCLK \downarrow Setup Time (Noncontinuous SCLK Input) $\overline{SYNC}\downarrow$ to SCLK \downarrow Setup Time (Continuous SCLK Input)
t_4	$0.6 t_{SCLK}$	ns min	$\overline{SYNC}\downarrow$ to SCLK \downarrow Setup Time, Interface Mode 4 Only
t_5^5	30	ns max	Delay from $\overline{SYNC}\downarrow$ until DOUT Three-State Disabled
t_{5A}^5	30	ns max	Delay from $\overline{SYNC}\downarrow$ until DIN Three-State Disabled
t_6^5	45	ns max	Data Access Time after SCLK \downarrow
t_7	30	ns min	Data Setup Time prior to SCLK \uparrow
t_8	20	ns min	Data Valid to SCLK Hold Time
t_9^6	$0.4 t_{SCLK}$	ns min	SCLK High Pulse Width (Interface Modes 4 and 5)
t_{10}^6	$0.4 t_{SCLK}$	ns min	SCLK Low Pulse Width (Interface Modes 4 and 5)
t_{11}	30 $30/0.4 t_{SCLK}$	ns min ns min/max	SCLK \uparrow to $\overline{SYNC}\uparrow$ Hold Time (Noncontinuous SCLK) (Continuous SCLK) Does Not Apply to Interface Mode 3
t_{11A}	50	ns max	SCLK \uparrow to $\overline{SYNC}\uparrow$ Hold Time
t_{12}^7	50	ns max	Delay from $\overline{SYNC}\uparrow$ until DOUT Three-State Enabled
t_{13}	90	ns max	Delay from SCLK \uparrow to DIN Being Configured as Output
t_{14}^8	50	ns max	Delay from SCLK \uparrow to DIN Being Configured as Input
t_{15}	$2.5 t_{CLKIN}$	ns max	$\overline{CAL}\uparrow$ to $BUSY\uparrow$ Delay
t_{16}	$2.5 t_{CLKIN}$	ns max	$\overline{CONVST}\downarrow$ to $BUSY\uparrow$ Delay in Calibration Sequence
t_{CAL}^9	41.7	ms typ	Full Self-Calibration Time, Master Clock Dependent ($250026 t_{CLKIN}$)
t_{CAL1}^9	37.04	ms typ	Internal DAC Plus System Full-Scale Calibration Time, Master Clock Dependent ($222228 t_{CLKIN}$)
t_{CAL2}^9	4.63	ms typ	System Offset Calibration Time, Master Clock Dependent ($27798 t_{CLKIN}$)
t_{DELAY}	65	ns max	Delay from CLK to SCLK

NOTES

¹Sample tested at 25°C to ensure compliance. All input signals are specified with $t_r = t_f = 5\text{ ns}$ (10% to 90% of V_{DD}) and timed from a voltage level of 1.6 V. See Table X and timing diagrams for different interface modes and calibration.

²Mark/space ratio for the master clock input is 40/60 to 60/40.

³For Interface Modes 1, 2, 3, the SCLK maximum frequency will be 10 MHz. For Interface Modes 4 and 5, the SCLK will be an output and the frequency will be f_{CLKIN} .

⁴The \overline{CONVST} pulse width will only apply for normal operation. When the part is in power-down mode, a different \overline{CONVST} pulse width will apply (see Power-Down section).

⁵Measured with the load circuit of Figure 1 and defined as the time required for the output to cross 0.8 V or 2.4 V.

⁶For self-clocking mode (Interface Modes 4, 5), the nominal SCLK high and low times will be $0.5 t_{SCLK} = 0.5 t_{CLKIN}$.

⁷The time t_{12} is derived from the measured time taken by the data outputs to change 0.5 V when loaded with the circuit of Figure 1. The measured number is then extrapolated back to remove the effects of charging or discharging the 50 pF capacitor. This means that t_{12} as quoted in the timing characteristics is the true bus relinquish time of the part and is independent of the bus loading.

⁸The time t_{14} is derived from the measured time taken by the data outputs to change 0.5 V when loaded with the circuit of Figure 1. The measured number is then extrapolated back to remove the effects of charging or discharging the 50 pF capacitor. This means that the time quoted in the timing characteristics is the true delay of the part in turning off the output drivers and configuring the DIN line as an input. Once this time has elapsed, the user can drive the DIN line knowing that a bus conflict will not occur.

⁹The typical time specified for the calibration times is for a master clock of 6 MHz.

Specifications subject to change without notice.

AD7851

TYPICAL TIMING DIAGRAMS

Figures 2 and 3 show typical read and write timing diagrams. Figure 2 shows the reading and writing after conversion in Interface Modes 2 and 3. To attain the maximum sample rate of 285 kHz in Interface Modes 2 and 3, reading and writing must be performed during conversion. Figure 3 shows the timing diagram for Interface Modes 4 and 5 with sample rate of 285 kHz. At least a 330 ns acquisition time must be allowed (the time from the falling edge of BUSY to the next rising edge of CONVST) before the next conversion begins to ensure that the part is settled to the 14-bit level. If the user does not want to provide the $\overline{\text{CONVST}}$ signal, the conversion can be initiated in software by writing to the control register.

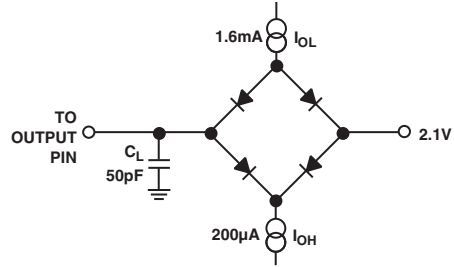

Figure 1. Load Circuit for Digital Output Timing Specifications

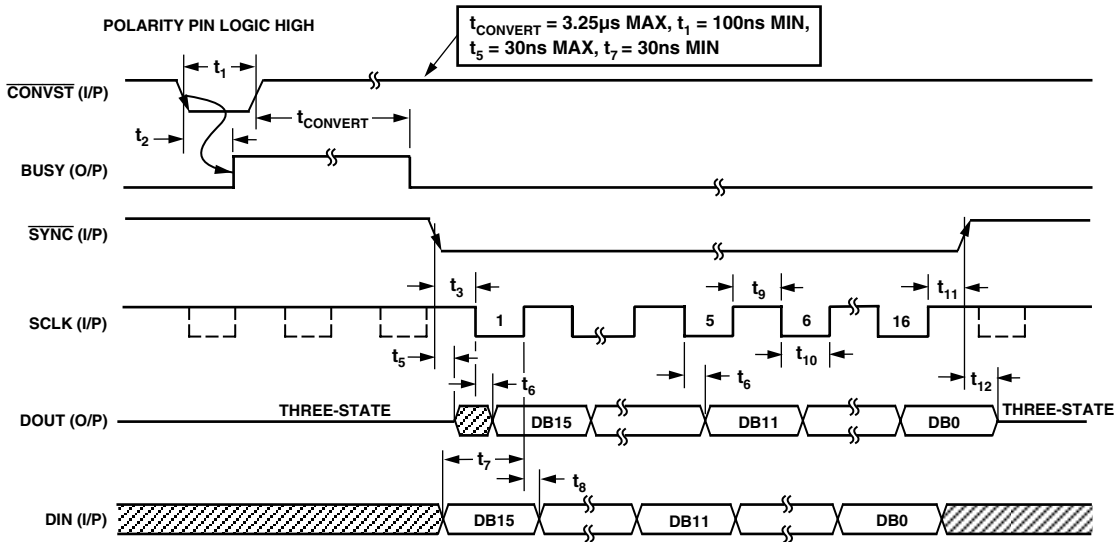

Figure 2. Timing Diagram (Typical Read and Write Operation for Interface Modes 2, 3)

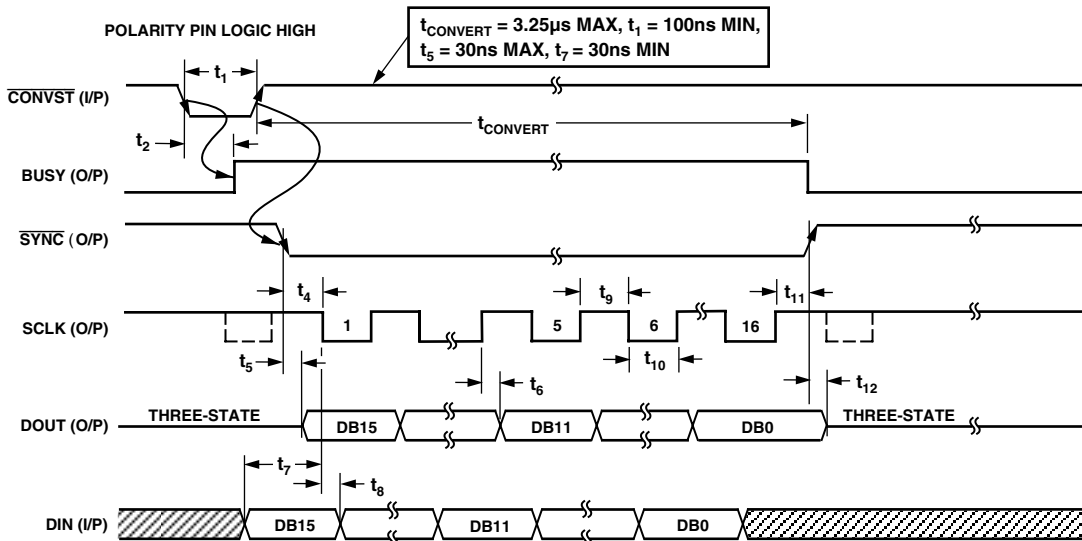

Figure 3. Timing Diagram (Typical Read and Write Operation for Interface Modes 4, 5)

ABSOLUTE MAXIMUM RATINGS¹

(T_A = 25°C, unless otherwise noted.)

AV _{DD} to AGND-0.3 V to +7 V
DV _{DD} to DGND-0.3 V to +7 V
AV _{DD} to DV _{DD} -0.3 V to +0.3 V
Analog Input Voltage to AGND -0.3 V to AV _{DD} + 0.3 V
Digital Input Voltage to DGND -0.3 V to DV _{DD} + 0.3 V
Digital Output Voltage to DGND -0.3 V to DV _{DD} + 0.3 V
REF _{IN} /REF _{OUT} to AGND-0.3 V to AV _{DD} + 0.3 V
Input Current to Any Pin Except Supplies ² ±10 mA

Operating Temperature Range

Commercial (A, K Versions)-40°C to +125°C
Storage Temperature Range-65°C to +150°C

Junction Temperature 150°C

PDIP Package, Power Dissipation 450 mW

θ_{JA} Thermal Impedance 105°C/W

θ_{JC} Thermal Impedance 34.7°C/W

Lead Temperature, (Soldering, 10 secs) 260°C

SOIC, SSOP Package, Power Dissipation 450 mW

θ_{JA} Thermal Impedance .. 75°C/W (SOIC), 122.28°C/W (SSOP)

θ_{JC} Thermal Impedance ... 25°C/W (SOIC), 31.25°C/W (SSOP)

Lead Temperature, Soldering

Vapor Phase (60 secs) 215°C

Infrared (15 secs) 220°C

ESD >1.5 kV

NOTES

¹Stresses above those listed under Absolute Maximum Ratings may cause permanent damage to the device. This is a stress rating only; functional operation of the device at these or any other conditions above those listed in the operational sections of this specification is not implied. Exposure to absolute maximum rating conditions for extended periods may affect device reliability.

²Transient currents of up to 100 mA will not cause SCR latch-up.

PINOUT FOR DIP, SOIC, AND SSOP

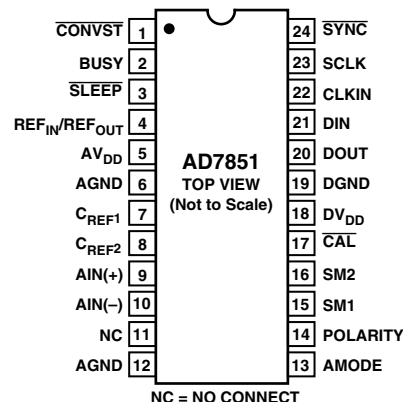

ORDERING GUIDE¹

Model	Temperature Range	Linearity Error (LSB) ²	Throughput Rate (kSPS)	Throughput at 125°C (kSPS)	Description	Package Options ³
AD7851AN	-40°C to +85°C	±2	333	238	PDIP	N-24
AD7851KN	0°C to 85°C	±1	285	238	PDIP	N-24
AD7851AR	-40°C to +85°C	±2	333	238	SOIC	R-24
AD7851AR-REEL	-40°C to +85°C	±2	333	238	SOIC	R-24
AD7851ARZ ³	-40°C to +85°C	±2	333	238	SOIC	R-24
AD7851ARZ-REEL ³	-40°C to +85°C	±2	333	238	SOIC	R-24
AD7851KR	0°C to 85°C	±1	285	238	SOIC	R-24
AD7851KR-REEL	0°C to 85°C	±1	285	238	SOIC	R-24
AD7851KRZ ³	0°C to 85°C	±1	285	238	SOIC	R-24
AD7851KRZ-REEL ³	0°C to 85°C	±1	285	238	SOIC	R-24
AD7851ARS	-40°C to +85°C	±2	333	238	SSOP	RS-24
AD7851ARS-REEL	-40°C to +85°C	±2	333	238	SSOP	RS-24
EVAL-AD7851CB ⁴					Evaluation Board	
EVAL-CONTROL BRD ⁵					Controller Board	

NOTES

¹Both A and K Grades are guaranteed up to 125°C, but at a lower throughput of 238 kHz (5 MHz).

²Linearity error refers to the integral linearity error.

³Z = Pb-free part.

⁴This can be used as a standalone evaluation board or in conjunction with the EVAL-CONTROL BOARD for evaluation/demonstration purposes.

⁵This board is a complete unit allowing a PC to control and communicate with all Analog Devices, Inc. evaluation boards ending in the CB designators. To order a complete evaluation kit, the particular ADC evaluation board needs to be ordered, e.g., EVAL-AD7851CB, the EVAL-CONTROL BRD2, and a 12 V ac transformer. See the Evaluation Board application note for more information.

CAUTION

ESD (electrostatic discharge) sensitive device. Electrostatic charges as high as 4000 V readily accumulate on the human body and test equipment and can discharge without detection. Although the AD7851 features proprietary ESD protection circuitry, permanent damage may occur on devices subjected to high energy electrostatic discharges. Therefore, proper ESD precautions are recommended to avoid performance degradation or loss of functionality.



AD7851

TERMINOLOGY

Integral Nonlinearity

This is the maximum deviation from a straight line passing through the endpoints of the ADC transfer function. The endpoints of the transfer function are zero scale, a point 1/2 LSB below the first code transition, and full scale, a point 1/2 LSB above the last code transition.

Differential Nonlinearity

This is the difference between the measured and the ideal 1 LSB change between any two adjacent codes in the ADC.

Total Unadjusted Error

This is the deviation of the actual code from the ideal code taking all errors into account (gain, offset, integral nonlinearity, and other errors) at any point along the transfer function.

Unipolar Offset Error

This is the deviation of the first code transition (00 . . . 000 to 00 . . . 001) from the ideal AIN(+) voltage (AIN(-) + 1/2 LSB) when operating in unipolar mode.

Positive Full-Scale Error

This applies to unipolar and bipolar modes and is the deviation of the last code transition from the ideal AIN(+) voltage (AIN(-) + full scale - 1.5 LSB) after the offset error has been adjusted out.

Negative Full-Scale Error

This applies to bipolar mode only and is the deviation of the first code transition (10 . . . 000 to 10 . . . 001) from the ideal AIN(+) voltage (AIN(-) - $V_{REF}/2$ + 0.5 LSB).

Bipolar Zero Error

This is the deviation of the midscale transition (all 1s to all 0s) from the ideal AIN(+) voltage (AIN(-) - 1/2 LSB).

Track-and-Hold Acquisition Time

The track-and-hold amplifier returns into track mode at the end of conversion. Track-and-hold acquisition time is the time required for the output of the track-and-hold amplifier to reach its final value, within $\pm 1/2$ LSB, after the end of conversion.

Signal-to-(Noise + Distortion) Ratio

This is the measured ratio of signal-to-(noise + distortion) at the output of the ADC. The signal is the rms amplitude of the fundamental. Noise is the sum of all nonfundamental signals up to half the sampling frequency ($f_s/2$), excluding dc. The ratio is dependent on the number of quantization levels in the digitization process; the more levels, the smaller the quantization noise. The theoretical signal-to-(noise + distortion) ratio for an ideal N-bit converter with a sine wave input is given by

$$\text{Signal-to-(Noise + Distortion)} = (6.02 N + 1.76) \text{ dB}$$

Thus, for a 14-bit converter, this is 86 dB.

Total Harmonic Distortion

Total harmonic distortion (THD) is the ratio of the rms sum of harmonics to the fundamental. For the AD7851, it is defined as

$$\text{THD(dB)} = 20 \log \frac{\sqrt{(V_2^2 + V_3^2 + V_4^2 + V_5^2 + V_6^2)}}{V_1}$$

where V_1 is the rms amplitude of the fundamental and V_2 , V_3 , V_4 , V_5 , and V_6 are the rms amplitudes of the second through the sixth harmonics.

Peak Harmonic or Spurious Noise

Peak harmonic or spurious noise is defined as the ratio of the rms value of the next largest component in the ADC output spectrum (up to $f_s/2$ and excluding dc) to the rms value of the fundamental. Normally, the value of this specification is determined by the largest harmonic in the spectrum, but for parts where the harmonics are buried in the noise floor, it will be a noise peak.

Intermodulation Distortion

With inputs consisting of sine waves at two frequencies, f_a and f_b , any active device with nonlinearities will create distortion products at sum and difference frequencies of $m f_a \pm n f_b$ where $m, n = 0, 1, 2, 3$, etc. Intermodulation distortion terms are those for which neither m nor n are equal to zero. For example, the second-order terms include $(f_a + f_b)$ and $(f_a - f_b)$, while the third-order terms include $(2f_a + f_b)$, $(2f_a - f_b)$, $(f_a + 2f_b)$, and $(f_a - 2f_b)$.

Testing is performed using the CCIF standard where two input frequencies near the top end of the input bandwidth are used. In this case, the second-order terms are usually distanced in frequency from the original sine waves while the third-order terms are usually at a frequency close to the input frequencies. As a result, the second- and third-order terms are specified separately. The calculation of the intermodulation distortion is as per the THD specification where it is the ratio of the rms sum of the individual distortion products to the rms amplitude of the sum of the fundamentals expressed in dBs.

Power Supply Rejection Ratio (PSRR)

PSRR is defined as the ratio of the power in ADC output at frequency f to the power of the full-scale sine wave applied to the supply voltage (V_{DD}). The units are in LSB, % of FS per % of supply voltage, or expressed logarithmically, in dB (PSRR (dB) = $10 \log (P_f/P_{fs})$).

Full Power Bandwidth (FPBW)

FPBW is that frequency at which the amplitude of the reconstructed fundamental (using FFTs and neglecting harmonics and SNR) is reduced by 3 dB for a full-scale input.

PIN FUNCTION DESCRIPTIONS

Pin No.	Mnemonic	Description
1	$\overline{\text{CONVST}}$	Convert Start. Logic input. A low-to-high transition on this input puts the track-and-hold into its hold mode and starts conversion. When this input is not used, it should be tied to DV_{DD} .
2	BUSY	Busy Output. The busy output is triggered high by the falling edge of $\overline{\text{CONVST}}$ or rising edge of $\overline{\text{CAL}}$ and remains high until conversion is completed. BUSY is also used to indicate when the AD7851 has completed its on-chip calibration sequence.
3	$\overline{\text{SLEEP}}$	Sleep Input/Low Power Mode. A Logic 0 initiates a sleep and all circuitry is powered down, including the internal voltage reference, provided there is no conversion or calibration being performed. Calibration data is retained. A Logic 1 results in normal operation. See Power-Down section for more details.
4	$\text{REF}_{\text{IN}}/\text{REF}_{\text{OUT}}$	Reference Input/Output. This pin is connected to the internal reference through a series resistor and is the reference source for the analog-to-digital converter. The nominal reference voltage is 4.096 V and this appears at the pin. This pin can be overdriven by an external reference or can be taken as high as AV_{DD} . When this pin is tied to AV_{DD} , or when an externally applied reference approaches V_{DD} , then the C_{REF1} pin should also be tied to AV_{DD} .
5	AV_{DD}	Analog Positive Supply Voltage, $5.0 \text{ V} \pm 5\%$.
6, 12	AGND	Analog Ground. Ground reference for track and hold, reference, and DAC.
7	C_{REF1}	Reference Capacitor (0.1 μF ceramic disc in parallel with a 470 nF tantalum). This external capacitor is used as a charge source for the internal DAC. The capacitor should be tied between the pin and AGND.
8	C_{REF2}	Reference Capacitor (0.01 μF ceramic disc). This external capacitor is used in conjunction with the on-chip reference. The capacitor should be tied between the pin and AGND.
9	$\text{AIN}(+)$	Analog Input. Positive input of the pseudo-differential analog input. Cannot go below AGND or above AV_{DD} at any time and cannot go below $\text{AIN}(-)$ when the unipolar input range is selected.
10	$\text{AIN}(-)$	Analog Input. Negative input of the pseudo-differential analog input. Cannot go below AGND or above AV_{DD} at any time.
11	NC	No Connect Pin.
13	AMODE	Analog Mode Pin. This pin allows two different analog input ranges to be selected. A Logic 0 selects range 0 to V_{REF} (i.e., $\text{AIN}(+) - \text{AIN}(-) = 0$ to V_{REF}). In this case, $\text{AIN}(+)$ cannot go below $\text{AIN}(-)$ and $\text{AIN}(-)$ cannot go below AGND. A Logic 1 selects range $-\text{V}_{\text{REF}}/2$ to $+\text{V}_{\text{REF}}/2$ (i.e., $\text{AIN}(+) - \text{AIN}(-) = -\text{V}_{\text{REF}}/2$ to $+\text{V}_{\text{REF}}/2$). In this case, $\text{AIN}(+)$ cannot go below AGND so that $\text{AIN}(-)$ needs to be biased to $+\text{V}_{\text{REF}}/2$ to allow $\text{AIN}(+)$ to go from 0 V to $+\text{V}_{\text{REF}}$ V.
14	POLARITY	Serial Clock Polarity. This pin determines the active edge of the serial clock (SCLK). Toggling this pin will reverse the active edge of the serial clock (SCLK). A Logic 1 means that the serial clock (SCLK) idles high and a Logic 0 means that the serial clock (SCLK) idles low. It is best to refer to the timing diagrams and Table IX for the SCLK active edges.
15	SM1	Serial Mode Select Pin. This pin is used in conjunction with the SM2 pin to give different modes of operation as described in Table X.
16	SM2	Serial Mode Select Pin. This pin is used in conjunction with the SM1 pin to give different modes of operation as described in Table X.
17	$\overline{\text{CAL}}$	Calibration Input. This pin has an internal pull-up current source of 0.15 μA . A Logic 0 on this pin resets all calibration control logic and initiates a calibration on its rising edge. There is the option of connecting a 10 nF capacitor from this pin to DGND to allow for an automatic self-calibration on power-up. This input overrides all other internal operations. If the autocalibration is not required, then this pin should be tied to a logic high.
18	DV_{DD}	Digital Supply Voltage, $5.0 \text{ V} \pm 5\%$.
19	DGND	Digital Ground. Ground reference point for digital circuitry.
20	DOUT	Serial Data Output. The data output is supplied to this pin as a 16-bit serial word.
21	DIN	Serial Data Input. The data to be written is applied to this pin in serial form (16-bit word). This pin can act as an input pin or as a input and output pin depending on the serial interface mode the part is in (see Table X).
22	CLKIN	Master Clock Signal for the Device (6 MHz or 7 MHz). Sets the conversion and calibration times.
23	SCLK	Serial Port Clock. Logic input/output. The SCLK pin is configured as an input or output, dependent on the type of serial data transmission (self-clocking or external-clocking) that has been selected by the SM1 and SM2 pins. The SCLK idles high or low depending on the state of the POLARITY pin.
24	$\overline{\text{SYNC}}$	This pin can be an input level triggered active low (similar to a chip select in one case and to a frame sync in the other) or an output (similar to a frame sync) pin depending on SM1, SM2 (see Table X).

AD7851

AD7851 ON-CHIP REGISTERS

The AD7851 powers up with a set of default conditions, and the user need not ever write to the device. In this case, the AD7851 will operate as a read-only ADC. The AD7851 still retains the flexibility for performing a full power-down and a full self-calibration. Note that the DIN pin should be tied to DGND for operating the AD7851 as a read-only ADC.

Extra features and flexibility, such as performing different power-down options, different types of calibrations, including system calibration, and software conversion starts can be selected by writing to the part.

The AD7851 contains a **control register**, **ADC output data register**, **status register**, **test register**, and **10 calibration registers**. The control register is write-only, the ADC output data register and the status register are read-only, and the test and calibration registers are both read/write registers. The test register is used for testing the part and should not be written to.

Addressing the On-Chip Registers

Writing

A write operation to the AD7851 consists of 16 bits. The two MSBs, ADDR0 and ADDR1, are decoded to determine which register is addressed, and the subsequent 14 bits of data are written to the addressed register. It is not until all 16 bits are written that the data is latched into the addressed register. Table I shows the decoding of the address bits, while Figure 4 shows the overall write register hierarchy.

Table I. Write Register Addressing

ADDR1	ADDR0	Comment
0	0	This combination does not address any register so the subsequent 14 data bits are ignored.
0	1	This combination addresses the TEST REGISTER . The subsequent 14 data bits are written to the test register.
1	0	This combination addresses the CALIBRATION REGISTERS . The subsequent 14 data bits are written to the selected calibration register.
1	1	This combination addresses the CONTROL REGISTER . The subsequent 14 data bits are written to the control register.

Reading

To read from the various registers the user must first write to Bits 6 and 7 in the Control Register, RDSLT0 and RDSLT1. These bits are decoded to determine which register is addressed during a read operation. Table II shows the decoding of the read address bits while Figure 5 shows the overall read register hierarchy. The power-up status of these bits is 00 so that the default read will be from the ADC output data register.

Once the read selection bits are set in the control register, all subsequent read operations that follow will be from the selected register until the read selection bits are changed in the control register.

Table II. Read Register Addressing

RDSLT1	RDSLT0	Comment
0	0	All successive read operations will be from ADC OUTPUT DATA REGISTER . This is the power-up default setting. There will always be two leading zeros when reading from the ADC output data register.
0	1	All successive read operations will be from TEST REGISTER .
1	0	All successive read operations will be from CALIBRATION REGISTERS .
1	1	All successive read operations will be from STATUS REGISTER .

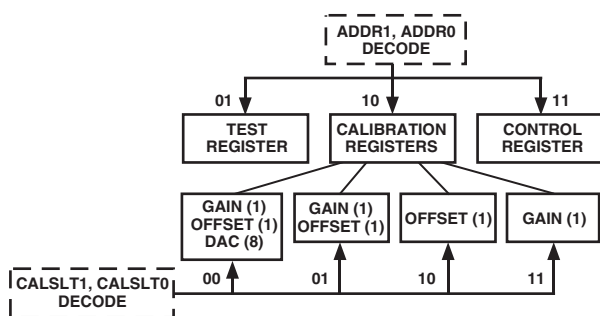

Figure 4. Write Register Hierarchy/Address Decoding

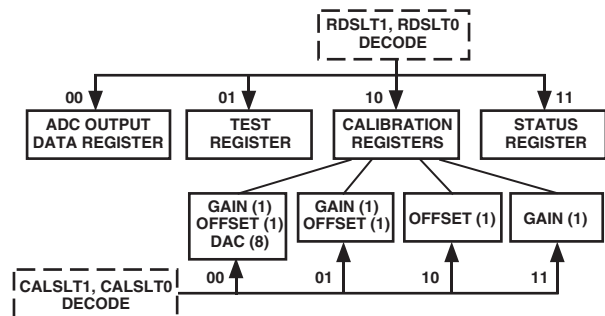

Figure 5. Read Register Hierarchy/Address Decoding

CONTROL REGISTER

The arrangement of the control register is shown below. The control register is a write-only register and contains 14 bits of data. The control register is selected by putting two 1s in ADDR1 and ADDR0. The function of the bits in the control register are described below. The power-up status of all bits is 0.

MSB						
ZERO	ZERO	ZERO	ZERO	PMGT1	PMGT0	RDSL1
RDSL0	$2/\bar{3}$ MODE	$\overline{\text{CONVST}}$	CALMD	CALSL1	CALSL0	STCAL
LSB						

Control Register Bit Function Descriptions

Bit No.	Mnemonic	Comment
13	ZERO	These four bits must be set to 0 when writing to the control register.
12	ZERO	
11	ZERO	
10	ZERO	
9	PMGT1	Power Management Bits. These two bits are used with the $\overline{\text{SLEEP}}$ pin for putting the part into various power-down modes (see Power-Down section for more details).
8	PMGT0	
7	RDSL1	These two bits determine which register is addressed for the read operations. See Table II.
6	RDSL0	
5	$2/\bar{3}$ MODE	Interface Mode Select Bit. With this bit set to 0, Interface Mode 2 is enabled. With this bit set to 1, Interface Mode 1 is enabled where DIN is used as an output as well as an input. This bit is set to 0 by default after every read cycle; thus when using Interface Mode 1, this bit needs to be set to 1 in every write cycle.
4	$\overline{\text{CONVST}}$	Conversion Start Bit. A Logic 1 in this bit position starts a single conversion, and this bit is automatically reset to 0 at the end of conversion. This bit may also be used in conjunction with system calibration (see Calibration section).
3	CALMD	Calibration Mode Bit. A 0 here selects self-calibration and a 1 selects a system calibration (see Table III).
2	CALSL1	Calibration Selection Bits and Start Calibration Bit. These bits have two functions: With the STCAL bit set to 1, the CALSL1 and CALSL0 bits determine the type of calibration performed by the part (see Table III). The STCAL bit is automatically reset to 0 at the end of calibration. With the STCAL bit set to 0, the CALSL1 and CALSL0 bits are decoded to address the calibration register for read/write of calibration coefficients (see section on Calibration Registers for more details).
1	CALSL0	
0	STCAL	

Table III. Calibration Selection

CALMD	CALSL1	CALSL0	Calibration Type
0	0	0	A full internal calibration is initiated where the internal DAC is calibrated followed by the internal gain error, and finally the internal offset error is calibrated out. This is the default setting.
0	0	1	Here the internal gain error is calibrated out followed by the internal offset error calibrated out.
0	1	0	This calibrates out the internal offset error only.
0	1	1	This calibrates out the internal gain error only.
1	0	0	A full system calibration is initiated here where first the internal DAC is calibrated, followed by the system gain error, and finally the system offset error is calibrated out.
1	0	1	Here the system gain error is calibrated out followed by the system offset error .
1	1	0	This calibrates out the system offset error only.
1	1	1	This calibrates out the system gain error only.

AD7851

STATUS REGISTER

The arrangement of the status register is shown below. The status register is a read-only register and contains 16 bits of data. The status register is selected by first writing to the control register and putting two 1s in RDSLT1 and RDSLT0. The function of the bits in the status register is described below. The power-up status of all bits is 0.

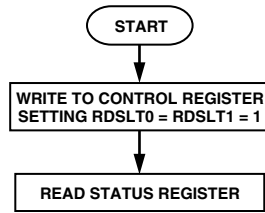

Figure 6. Flowchart for Reading the Status Register

MSB							
ZERO	BUSY	ZERO	ZERO	ZERO	ZERO	PMGT1	PMGT0
RDSLT1	RDSLT0	2/3 MODE	X	CALMD	CALSLT1	CALSLT0	STCAL
LSB							

Status Register Bit Function Descriptions

Bit No.	Mnemonic	Comment
15	ZERO	This bit is always 0.
14	BUSY	Conversion/Calibration Busy Bit. When this bit is 1, this indicates that there is a conversion or calibration in progress. When this bit is 0, there is no conversion or calibration in progress.
13	ZERO	These four bits are always 0.
12	ZERO	
11	ZERO	
10	ZERO	
9	PMGT1	Power Management Bits. These bits along with the $\overline{\text{SLEEP}}$ pin will indicate whether the part is in a power-down mode. (See Table VI in the Power-Down Options section for description.)
8	PMGT0	
7	RDSLT1	Both these bits are always 1 indicating it is the status register that is being read. (See Table II.)
6	RDSLT0	
5	2/3 MODE	Interface Mode Select Bit. With this bit 0, the device is in Interface Mode 2. With this bit 1, the device is in Interface Mode 1. This bit is reset to 0 after every read cycle.
4	X	Don't care bit.
3	CALMD	Calibration Mode Bit. A 0 in this bit indicates self-calibration is selected, and 1 in this bit indicates a system calibration is selected (see Table III).
2	CALSLT1	Calibration Selection Bits and Start Calibration Bit. The STCAL bit is read as a 1 if a calibration is in progress and as a 0 if there is no calibration in progress. The CALSLT1 and CALSLT0 bits indicate which of the calibration registers are addressed for reading and writing (see the Calibration Registers section for more details)
1	CALSLT0	
0	STCAL	

CALIBRATION REGISTERS

The AD7851 has 10 calibration registers in all, 8 for the DAC, 1 for the offset, and 1 for gain. Data can be written to or read from all 10 calibration registers. In self- and system calibration, the part automatically modifies the calibration registers; only if the user needs to modify the calibration registers should an attempt be made to read from and write to the calibration registers.

Addressing the Calibration Registers

The calibration selection bits in the control register, CALSLT1 and CALSLT0, determine which of the calibration registers are addressed (see Table IV). The addressing applies to both the read and write operations for the calibration registers. The user should not attempt to read from and write to the calibration registers at the same time.

Table IV. Calibration Register Addressing

CALSLT1	CALSLT0	This Combination Addresses the
0	0	Gain (1), Offset (1) and DAC Registers (8). Ten registers in total.
0	1	Gain (1) and Offset (1) Registers. Two registers in total.
1	0	Offset Register. One register in total.
1	1	Gain Register. One register in total.

Writing to/Reading from the Calibration Registers

For writing to the calibration registers, a write to the control register is required to set the CALSLT0 and CALSLT1 bits. For reading from the calibration registers, a write to the control register is required to set the CALSLT0 and CALSLT1 bits, but also to set the RDSLT1 and RDSLT0 bits to 10 (this addresses the calibration registers for reading). The calibration register pointer is reset on writing to the control register setting the CALSLT1 and CALSLT0 bits, or upon completion of all the calibration register write/read operations. When reset, it points to the first calibration register in the selected write/read sequence. The calibration register pointer will point to the gain calibration register upon reset in all but one case, this case being where the offset calibration register is selected on its own (CALSLT1 = 1, CALSLT0 = 0). Where more than one calibration register is being accessed, the calibration register pointer will be automatically incremented after each calibration register write/read operation. The order in which the 10 calibration registers are arranged is shown in Figure 7. The user may abort at any time before all the calibration register write/read operations are completed, and the next control register write operation will reset the calibration register pointer. The flowchart in Figure 8 shows the sequence for writing to the calibration registers and Figure 9 shows the sequence for reading.

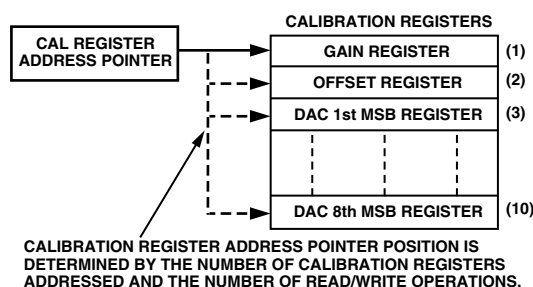

Figure 7. Calibration Register Arrangement

When reading from the calibration registers there will always be two leading zeros for each of the registers. When operating in Serial Interface Mode 1, the read operations to the calibration registers cannot be aborted. The full number of read operations must be completed (see the Serial Interface Summary section for more detail).

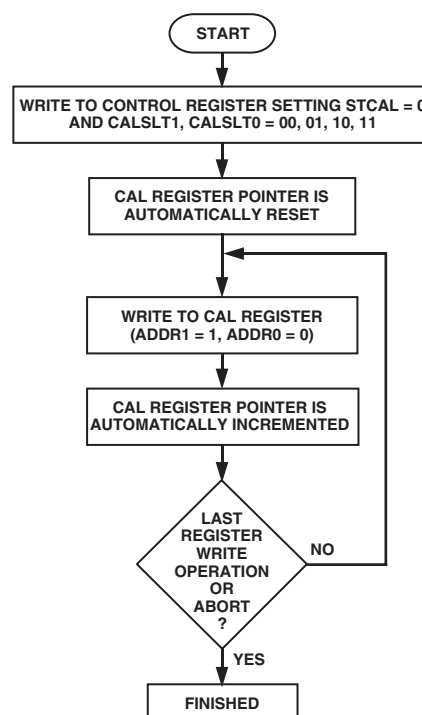

Figure 8. Flowchart for Writing to the Calibration Registers

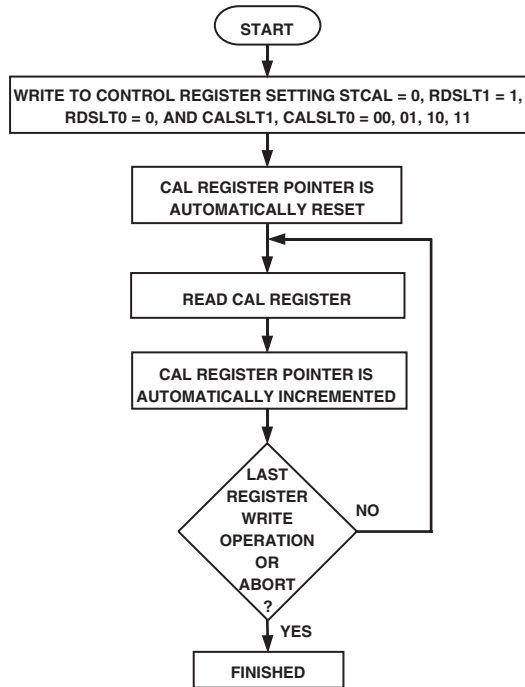

Figure 9. Flowchart for Reading from the Calibration Registers

Adjusting the Offset Calibration Register

The offset calibration register contains 16 bits, 2 leading 0s, and 14 data bits. By changing the contents of the offset register, different amounts of offset on the analog input signal can be compensated for. Increasing the number in the offset calibration register compensates for the negative offset on the analog input signal, and decreasing the number in the offset calibration register compensates for the positive offset on the analog input signal. The default value of the offset calibration register is approximately 0010 0000 0000 0000. This is not an exact value, but the value in the offset register should be close to this value. Each of the 14 data bits in the offset register is binary weighted; the MSB has a weighting of 5% of the reference voltage, the MSB-1 has a weighting of 2.5%, the MSB-2 has a weighting of 1.25%, and so on down to the LSB which has a weighting of 0.0006%.

This gives a resolution of $\pm 0.0006\%$ of V_{REF} approximately. More accurately the resolution is $\pm (0.05 \times V_{REF})/2^{13} \text{ V} = \pm 0.015 \text{ mV}$, with a 2.5 V reference. The maximum offset that can be compensated for is $\pm 5\%$ of the reference voltage, which equates to $\pm 125 \text{ mV}$ with a 2.5 V reference and $\pm 250 \text{ mV}$ with a 5 V reference.

- Q. If a +20 mV offset is present in the analog input signal and the reference voltage is 2.5 V, what code needs to be written to the offset register to compensate for the offset?
- A. The 2.5 V reference implies that the resolution in the offset register is $5\% \times 2.5 \text{ V}/2^{13} = 0.015 \text{ mV}$. $20 \text{ mV}/0.015 \text{ mV} = 1310.72$; rounding to the nearest number gives 1311. In binary terms this is 0101 0001 1111, therefore decrease the offset register by 0101 0001 1111.

This method of compensating for offset in the analog input signal allows for fine-tuning the offset compensation. If the offset on the analog input signal is known, there will be no need to apply the offset voltage to the analog input pins to do a system calibration. The offset compensation can take place in software.

Adjusting the Gain Calibration Register

The gain calibration register contains 16 bits, 2 leading 0s, and 14 data bits. The data bits are binary weighted as in the offset calibration register. The gain register value is effectively multiplied by the analog input to scale the conversion result over the full range. Increasing the gain register compensates for a smaller analog input range and decreasing the gain register compensates for a larger input range. The maximum analog input range that the gain register can compensate for is 1.025 times the reference voltage, and the minimum input range is 0.975 times the reference voltage.

CIRCUIT INFORMATION

The AD7851 is a fast, 14-bit single-supply ADC. The part requires an external 6/7 MHz master clock (CLKIN), two C_{REF} capacitors, a \overline{CONVST} signal to start conversion, and power supply decoupling capacitors. The part provides the user with track-and-hold, on-chip reference, calibration features, ADC, and serial interface logic functions on a single chip. The ADC section of the AD7851 consists of a conventional successive approximation converter based around a capacitor DAC. The AD7851 accepts an analog input range of 0 V to $+V_{DD}$ where the reference can be tied to V_{DD} . The reference input to the part is buffered on-chip.

A major advantage of the AD7851 is that a conversion can be initiated in software as well as applying a signal to the \overline{CONVST} pin. Another innovative feature of the AD7851 is self-calibration on power-up, which is initiated having a capacitor from the CAL pin to AGND, to give superior dc accuracy (see the Automatic Calibration on Power-On section). The part is available in a 24-lead SSOP package which offers the user considerable space-saving advantages over alternative solutions.

CONVERTER DETAILS

The master clock for the part must be applied to the CLKIN pin. Conversion is initiated on the AD7851 by pulsing the \overline{CONVST} input or by writing to the control register and setting the \overline{CONVST} bit to 1. On the rising edge of \overline{CONVST} (or at the end of the control register write operation), the on-chip track-and-hold goes from track to hold mode. The falling edge of the CLKIN signal which follows the rising edge of the \overline{CONVST} signal initiates the conversion, provided the rising edge of \overline{CONVST} occurs at least 10 ns typically before this CLKIN edge. The conversion cycle will take 18.5 CLKIN periods from this CLKIN falling edge. If the 10 ns setup time is not met, the conversion will take 19.5 CLKIN periods. The maxi-

imum specified conversion time is 3.25 μ s (6 MHz) and 2.8 μ s (7 MHz) for the A and K Grades, respectively, for the AD7851 (19.5 t_{CLKIN} , CLKIN = 6 MHz/7 MHz). When a conversion is completed, the BUSY output goes low, and then the result of the conversion can be read by accessing the data through the edge of serial interface. To obtain optimum performance from the part, the read operation should not occur during the conversion or 500 ns prior to the next \overline{CONVST} rising edge. However, the maximum throughput rates are achieved by reading/writing during conversion, and reading/writing during conversion is likely to degrade the signal-to-(noise + distortion) by only 0.5 dBs. The AD7851 can operate at throughput rates up to 333 kHz. For the AD7851, a conversion takes 19.5 CLKIN periods; 2 CLKIN periods are needed for the acquisition time giving a full cycle time of 3.59 μ s (= 279 kHz, CLKIN = 6 MHz) for the K grade and 3.08 μ s (= 325 kHz, CLKIN = 7 MHz) for the A grade.

TYPICAL CONNECTION DIAGRAM

Figure 10 shows a typical connection diagram for the AD7851. The DIN line is tied to DGND so that no data is written to the part. The AGND and the DGND pins are connected together at the device for good noise suppression. The CAL pin has a 0.01 μ F capacitor to enable an automatic self-calibration on power-up. The SCLK and \overline{SYNC} are configured as outputs by having SM1 and SM2 at DV_{DD} . The conversion result is output in a 16-bit word with 2 leading zeros followed by the MSB of the 14-bit result. Note that after the AV_{DD} and DV_{DD} power up, the part will require approximately 150 ms for the internal reference to settle and for the automatic calibration on power-up to be completed.

For applications where power consumption is a major concern, the SLEEP pin can be connected to DGND. (See the Power-Down Options section for more detail on low power applications.)

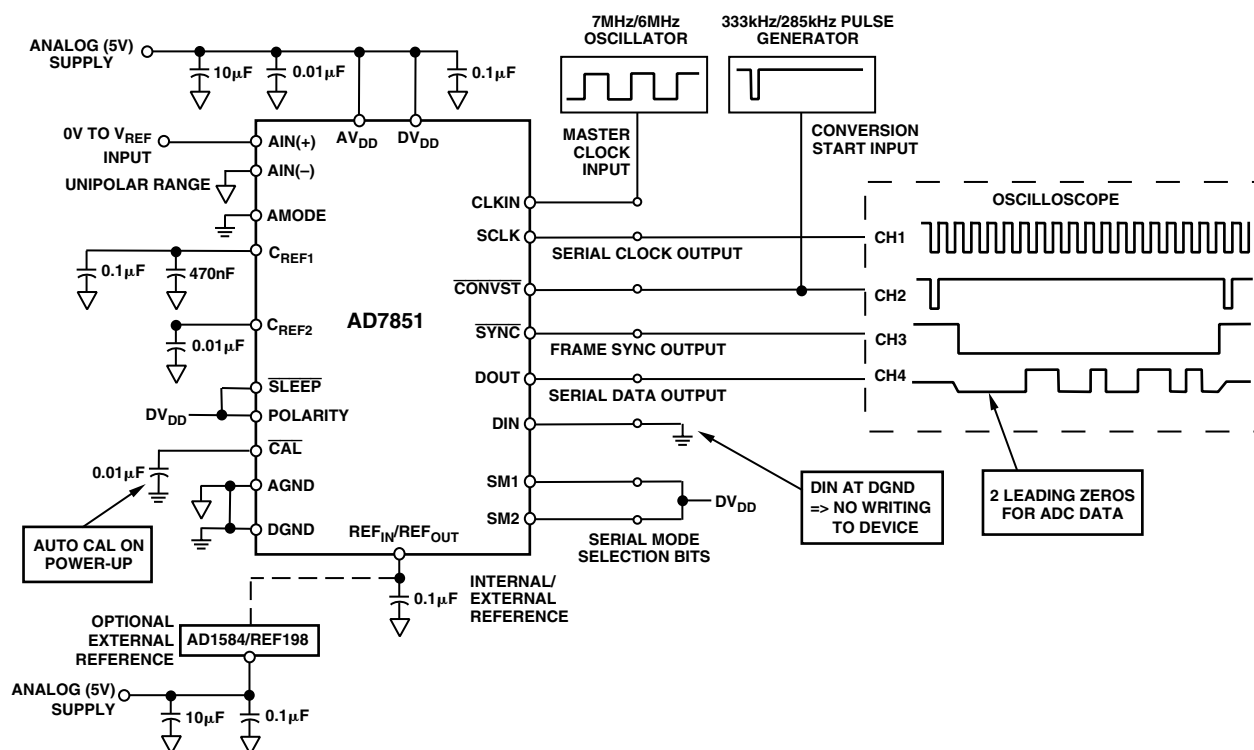

Figure 10. Typical Circuit

AD7851

ANALOG INPUT

The equivalent circuit of the analog input section is shown in Figure 11. During the acquisition interval, the switches are both in the track position and the AIN(+) charges the 20 pF capacitor through the 125 Ω resistance. On the rising edge of $\overline{\text{CONVST}}$, Switches SW1 and SW2 go into the hold position retaining charge on the 20 pF capacitor as a sample of the signal on AIN(+). The AIN(-) is connected to the 20 pF capacitor, and this unbalances the voltage at Node A at the input of the comparator. The capacitor DAC adjusts during the remainder of the conversion cycle to restore the voltage at Node A to the correct value. This action transfers a charge, representing the analog input signal, to the capacitor DAC which in turn forms a digital representation of the analog input signal. The voltage on the AIN(-) pin directly influences the charge transferred to the capacitor DAC at the hold instant. If this voltage changes during the conversion period, the DAC representation of the analog input voltage will be altered. Therefore, it is most important that the voltage on the AIN(-) pin remain constant during the conversion period. Furthermore, it is recommended that the AIN(-) pin always be connected to AGND or to a fixed dc voltage.

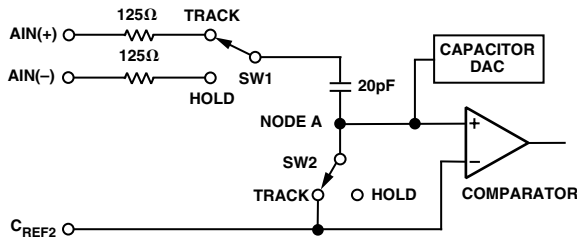

Figure 11. Analog Input Equivalent Circuit

Acquisition Time

The track and hold amplifier enters its tracking mode on the falling edge of the BUSY signal. The time required for the track and hold amplifier to acquire an input signal will depend on how quickly the 20 pF input capacitance is charged. The acquisition time is calculated using the formula

$$t_{ACQ} = 9 \times (R_{IN} + 125 \Omega) \times 20 \text{ pF}$$

where R_{IN} is the source impedance of the input signal, and 125 Ω, 20 pF is the input R, C.

DC/AC Applications

For dc applications, high source impedances are acceptable, provided there is enough acquisition time between conversions to charge the 20 pF capacitor. The acquisition time can be calculated from the above formula for different source impedances. For example, with $R_{IN} = 5 \text{ k}\Omega$, the required acquisition time will be 922 ns.

For ac applications, removing high frequency components from the analog input signal is recommended by use of an RC low-pass filter on the AIN(+) pin, as shown in Figure 13. In applications where harmonic distortion and signal-to-noise ratio are critical, the analog input should be driven from a low impedance source. Large source impedances will significantly affect the ac performance of the ADC. This may necessitate the use of an input buffer amplifier. The choice of the op amp will be a function of the particular application.

When no amplifier is used to drive the analog input, the source impedance should be limited to low values. The maximum source impedance will depend on the amount of total harmonic distortion (THD) that can be tolerated. The THD will increase as the source impedance increases, and the performance will degrade. Figure 12 shows a graph of the total harmonic distortion versus the analog input signal frequency for different source impedances. With the setup as in Figure 13, the THD is at the -90 dB level. With a source impedance of 1 kΩ and no capacitor on the AIN(+) pin, the THD increases with frequency.

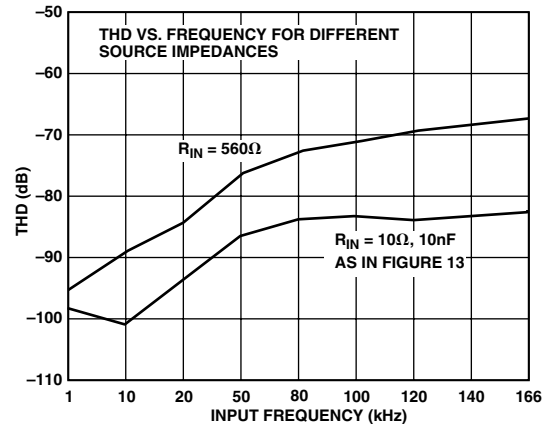

Figure 12. THD vs. Analog Input Frequency

In a single-supply application (5 V), the $V+$ and $V-$ of the op amp can be taken directly from the supplies to the AD7851 which eliminates the need for extra external power supplies. When operating with rail-to-rail inputs and outputs at frequencies greater than 10 kHz, care must be taken in selecting the particular op amp for the application. In particular, for single-supply applications the input amplifiers should be connected in a gain of -1 arrangement to get the optimum performance. Figure 13 shows the arrangement for a single-supply application with a 10 Ω and 10 nF low-pass filter (cutoff frequency 320 kHz) on the AIN(+) pin. Note that the 10 nF is a capacitor with good linearity to ensure good ac performance. Recommended single-supply op amp is the AD820.

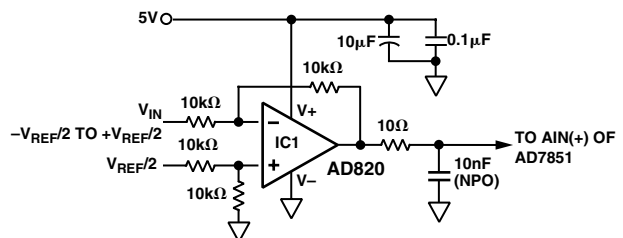

Figure 13. Analog Input Buffering

Input Ranges

The analog input range for the AD7851 is 0 V to V_{REF} in both the unipolar and bipolar ranges.

The only difference between the unipolar range and the bipolar range is that in the bipolar range the $AIN(-)$ has to be biased up to $+V_{REF}/2$ and the output coding is twos complement (see Table V and Figures 14 and 15). The unipolar or bipolar mode is selected by the $AMODE$ pin (0 for the unipolar range and 1 for the bipolar range).

Table V. Analog Input Connections

Analog Input Range	Input Connections		Connection Diagram	AMODE
	AIN(+)	AIN(-)		
0 V to V_{REF} ¹	V_{IN}	AGND	Figure 8	DGND
$\pm V_{REF}/2$ ²	V_{IN}	$V_{REF}/2$	Figure 9	DV_{DD}

NOTES

¹Output code format is straight binary.

²Range is $\pm V_{REF}/2$ biased about $V_{REF}/2$. Output code format is twos complement.

Note that the $AIN(-)$ pin on the AD7851 can be biased up above AGND in the unipolar mode also, if required. The advantage of biasing the lower end of the analog input range away from AGND is that the user does not have to have the analog input swing all the way down to AGND. This has the advantage in true single-supply applications that the input amplifier does not have to swing all the way down to AGND. The upper end of the analog input range is shifted up by the same amount. Care must be taken so that the bias applied does not shift the upper end of the analog input above the AV_{DD} supply. In the case where the reference is the supply, AV_{DD} , the $AIN(-)$ must be tied to AGND in unipolar mode.

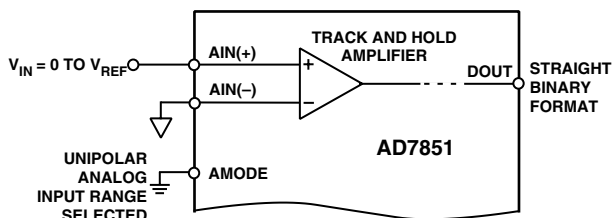

Figure 14. 0 V to V_{REF} Unipolar Input Configuration

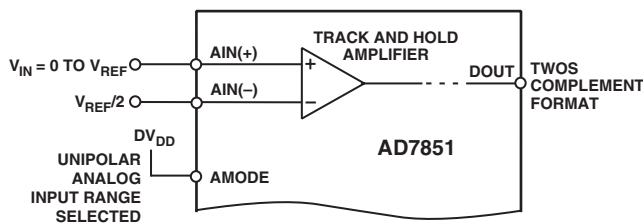

Figure 15. $\pm V_{REF}/2$ about $V_{REF}/2$ Bipolar Input Configuration

Transfer Functions

For the unipolar range, the designed code transitions occur midway between successive integer LSB values (i.e., 1/2 LSB, 3/2 LSBs, 5/2 LSBs . . . $FS - 3/2$ LSBs). The output coding is straight binary for the unipolar range with 1 LSB = $FS/16384$ = $4.096\text{ V}/16384$ = 0.25 mV when $V_{REF} = 4.096\text{ V}$. The ideal input/output transfer characteristic for the unipolar range is shown in Figure 16.

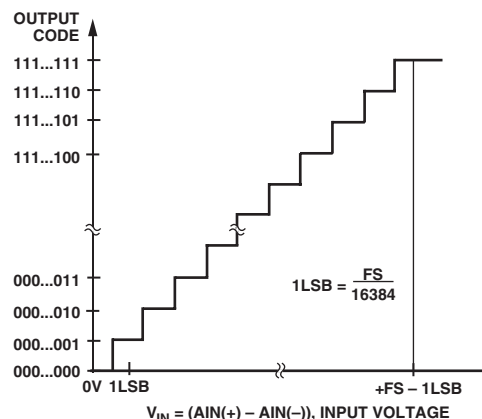

Figure 16. AD7851 Unipolar Transfer Characteristic

Figure 15 shows the AD7851's $\pm V_{REF}/2$ bipolar analog input configuration (where $AIN(+)$ cannot go below 0 V, so for the full bipolar range the $AIN(-)$ pin should be biased to $+V_{REF}/2$). Once again the designed code transitions occur midway between successive integer LSB values. The output coding is twos complement with 1 LSB = 16384 = $4.096\text{ V}/16384$ = 0.25 mV. The ideal input/output transfer characteristic is shown in Figure 17.

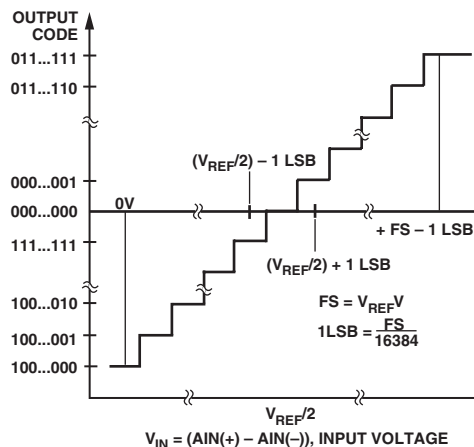

Figure 17. AD7851 Bipolar Transfer Characteristic

AD7851

REFERENCE SECTION

For specified performance, it is recommended that when using an external reference this reference should be between 4 V and the analog supply AV_{DD} . The connections for the relevant reference pins are shown in the typical connection diagrams. If the internal reference is being used, the REF_{IN}/REF_{OUT} pin should have a 100 nF capacitor connected to AGND very close to the REF_{IN}/REF_{OUT} pin. These connections are shown in Figure 18.

If the internal reference is required for use external to the ADC, it should be buffered at the REF_{IN}/REF_{OUT} pin and a 100 nF capacitor connected from this pin to AGND. The typical noise performance for the internal reference with 5 V supplies is $150 \text{ nV}/\sqrt{\text{Hz}}$ @ 1 kHz and dc noise is 100 μV p-p.

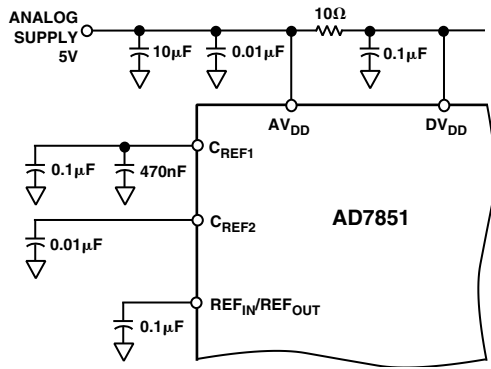

Figure 18. Relevant Connections When Using Internal Reference

The other option is that the REF_{IN}/REF_{OUT} pin be overdriven by connecting it to an external reference. This is possible due to the series resistance from the REF_{IN}/REF_{OUT} pin to the internal reference. This external reference can have a range that includes AV_{DD} . When using AV_{DD} as the reference source, the 100 nF capacitor from the REF_{IN}/REF_{OUT} pin to AGND should be as close as possible to the REF_{IN}/REF_{OUT} pin, and also the C_{REF1} pin should be connected to AV_{DD} to keep this pin at the same level as the reference. The connections for this arrangement are shown in Figure 19. When using AV_{DD} it may be necessary to add a resistor in series with the AV_{DD} supply. This will have the effect of filtering the noise associated with the AV_{DD} supply.

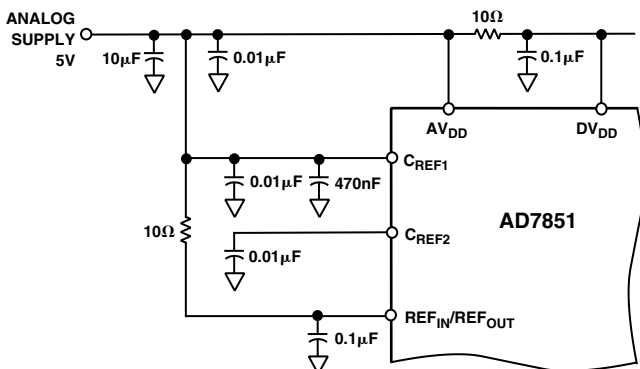

Figure 19. Relevant Connections When Using AV_{DD} as the Reference

AD7851 PERFORMANCE CURVES

Figure 20 shows a typical FFT plot for the AD7851 at 333 kHz sample rate and 10 kHz input frequency.

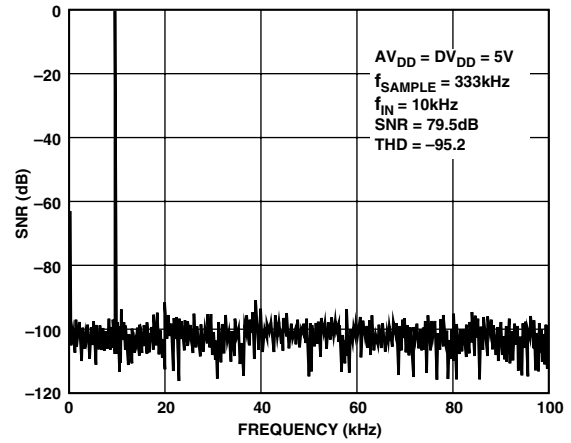

Figure 20. FFT Plot

Figure 21 shows the SNR versus frequency for a 5 V supply and a 4.096 external reference (5 V reference is typically 1 dB better performance).

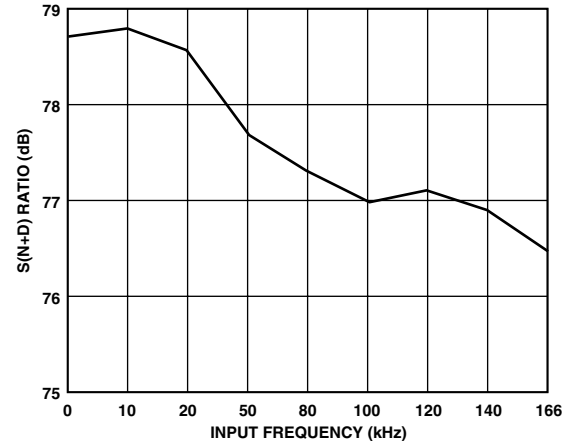

Figure 21. SNR vs. Frequency

Figure 22 shows the power supply rejection ratio versus frequency for the part. The power supply rejection ratio is defined as the ratio of the power in ADC output at frequency f to the power of a full-scale sine wave.

$$PSRR \text{ (dB)} = 10 \log (P_f/P_{fs})$$

P_f is the power at frequency f in ADC output, P_{fs} is the power of a full-scale sine wave. Here a 100 mV peak-to-peak sine wave is coupled onto the AV_{DD} supply while the digital supply is left unaltered.

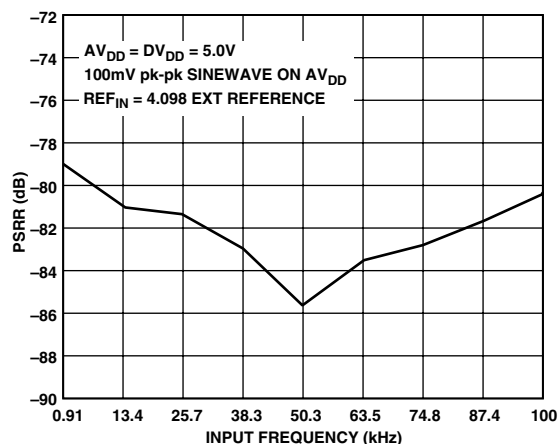

Figure 22. PSRR vs. Frequency

POWER-DOWN OPTIONS

The AD7851 provides flexible power management to allow the user to achieve the best power performance for a given throughput rate. The power management options are selected by programming the power management bits, PMGT1 and PMGT0, in the control register and by use of the SLEEP pin. Table VI summarizes the power-down options that are available and how they can be selected by using either software, hardware, or a combination of both. The AD7851 can be fully or partially powered down. When fully powered down, all the on-chip circuitry is powered down and I_{DD} is 1 μA typ. If a partial power-down is selected, then all the on-chip circuitry except the reference is powered down and I_{DD} is 400 μA typ. The choice of full or partial power-down does not give any significant improvement in throughput with a power-down between conversions. (This is discussed in the Power-Up Times section which follows.) But a partial power-down does allow the on-chip reference to be used externally even though the rest of the AD7851 circuitry is powered down. It also allows the AD7851 to be powered up faster after a long power-down period when using the on-chip reference. (See the Using the Internal (On-Chip) Reference section which follows.)

When using the SLEEP pin, the power management bits PMGT1 and PMGT0 should be set to 0 (default status on power-up). Bringing the SLEEP pin logic high ensures normal operation, and the part does not power down at any stage. This may be necessary if the part is being used at high throughput rates when it is not possible to power down between conversions. If the user wishes to power down between conversions at lower throughput rates (that is, <100 kSPS for the AD7851) to achieve better power performances, then the SLEEP pin should be tied logic low.

If the power-down options are to be selected in software only, then the SLEEP pin should be tied logic high. By setting the power management bits PMGT1 and PMGT0 as shown in Table VI, a full power-down, full power-up, full power-down between conversions, and a partial power-down between conversions can be selected.

A combination of hardware and software selection can also be used to achieve the desired effect.

Table VI. Power Management Options

PMGT1 Bit	PMGT0 Bit	SLEEP Pin	Comment
0	0	0	Full power-down between conversions (HW/SW)
0	0	1	Full power-up (HW/SW)
0	1	X	Full power-down between conversions (SW)
1	0	X	Full power-down (SW)
1	1	X	Partial power-down between conversions (SW)

SW = Software selection, HW = Hardware selection.

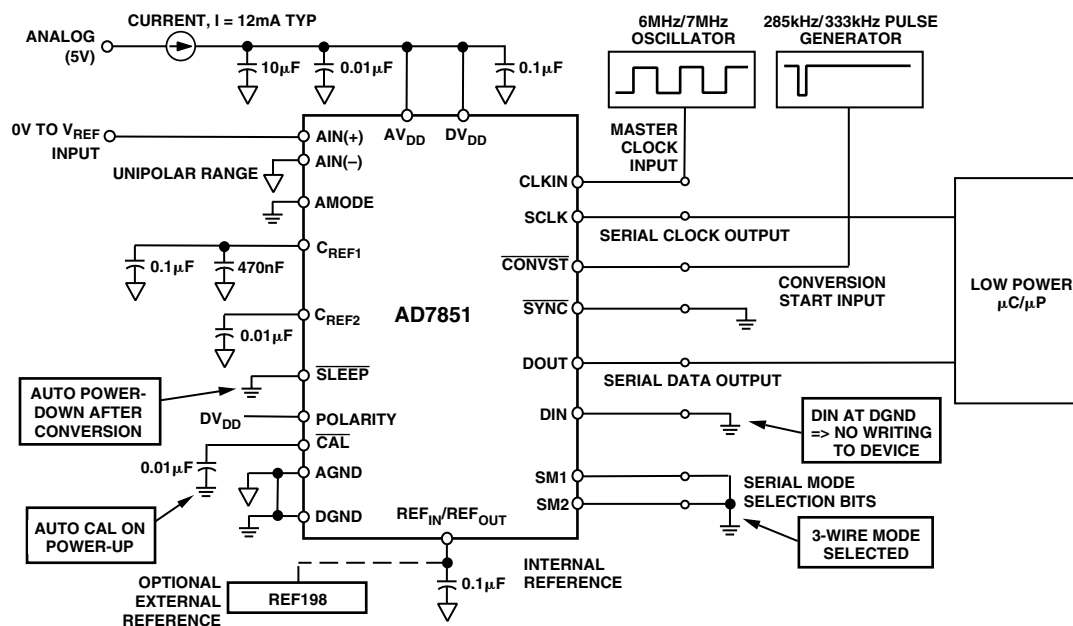

Figure 23. Typical Low Power Circuit

AD7851

POWER-UP TIMES

Using an External Reference

When the AD7851 is powered up, the part is powered up from one of two conditions: first, when the power supplies are initially powered up and; secondly, when the parts are powered up from either a hardware or software power-down (see previous section).

When AV_{DD} and DV_{DD} are powered up, the AD7851 enters a mode whereby the \overline{CONVST} signal initiates a timeout followed by a self-calibration. The total time taken for this timeout and calibration is approximately 35 ms (see the Automatic Calibration on Power-On section). During power-up, the functionality of the \overline{SLEEP} pin is disabled, that is, the part will not power down until the end of the calibration if \overline{SLEEP} is tied logic low. The power-up calibration mode can be disabled if the user writes to the control register before a \overline{CONVST} signal is applied. If the timeout and self-calibration are disabled, then the user must take into account the time required by the AD7851 to power up before a self-calibration is carried out. This power-up time is the time taken for the AD7851 to power up when power is first applied (300 μ s typ), or the time it takes the external reference to settle to the 14-bit level—whichever is longer.

The AD7851 powers up from a full hardware or software power-down in 5 μ s typ. This limits the throughput which the part is capable of to 120 kSPS for the K Grade and 126 kSPS for the A Grade when powering down between conversions. Figure 24 shows how power-down between conversions is implemented using the \overline{CONVST} pin. The user first selects the power-down between conversions option by using the \overline{SLEEP} pin and the power management bits, PMGT1 and PMGT0, in the control register (see previous section). In this mode, the AD7851 automatically enters a full power-down at the end of a conversion, that is, when $BUSY$ goes low. The falling edge of the next \overline{CONVST} pulse causes the part to power up. Assuming the external reference is left powered up, the AD7851 should be ready for normal operation 5 μ s after this falling edge. The rising edge of \overline{CONVST} initiates a conversion so the \overline{CONVST} pulse should be at least 5 μ s wide. The part automatically powers down on completion of the conversion. Where the software convert start is used, the part may be powered up in software before a conversion is initiated.

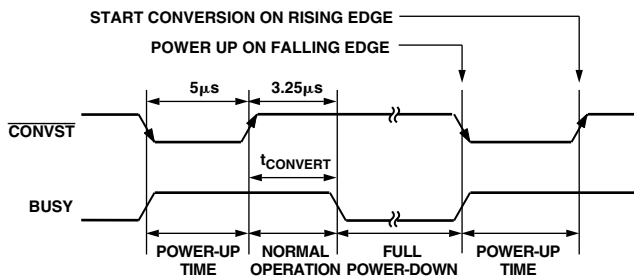

Figure 24. Using the \overline{CONVST} Pin to Power Up for a Conversion

Using the Internal (On-Chip) Reference

As in the case of an external reference, the AD7851 can power up from one of two conditions: power up after the supplies are connected or power up from a hardware/software power-down.

When using the on-chip reference and powering up when AV_{DD} and DV_{DD} are first connected, it is recommended that the power-up calibration mode be disabled as explained previously. When using the on-chip reference, the power-up time is effectively the time it takes to charge up the external capacitor on the REF_{IN}/REF_{OUT} pin. This time is given by the equation

$$t_{UP} = 9 \times R \times C$$

where $R \approx 150K$ and C = external capacitor.

The recommended value of the external capacitor is 100 nF; this gives a power-up time of approximately 135 ms before a calibration is initiated and normal operation should commence.

When C_{REF} is fully charged, the power-up time from a hardware or software power-down reduces to 5 μ s. This is because an internal switch opens to provide a high impedance discharge path for the reference capacitor during power-down—see Figure 25. An added advantage of the low charge leakage from the reference capacitor during power-down is that even though the reference is being powered down between conversions, the reference capacitor holds the reference voltage to within 0.5 LSBs with throughput rates of 100 samples/second and over with a full power-down between conversions. A high input impedance op amp, such as the AD707, should be used to buffer this reference capacitor if it is being used externally. Note, if the AD7851 is left in its powered-down state for more than 100 ms, the charge on C_{REF} will start to leak away and the power-up time will increase. If this long power-up time is a problem, the user can use a partial power-down for the last conversion so the reference remains powered up.

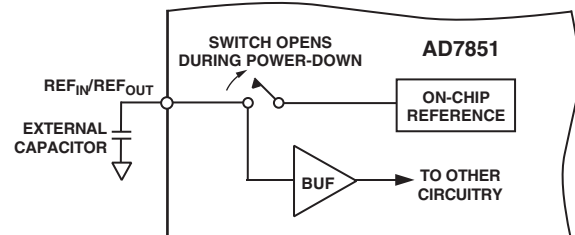

Figure 25. On-Chip Reference During Power-Down

POWER VS. THROUGHPUT RATE

The main advantage of a full power-down after a conversion is that it significantly reduces the power consumption of the part at lower throughput rates. When using this mode of operation, the AD7851 is only powered up for the duration of the conversion. If the power-up time of the AD7851 is taken to be 5 μ s and it is assumed that the current during power up is 12 mA typ, then power consumption as a function of throughput can easily be calculated. The AD7851 has a conversion time of 3.25 μ s with a 6 MHz external clock. This means the AD7851 consumes 12 mA typ for 8.25 μ s in every conversion cycle if the parts are powered down at the end of a conversion. The graph in Figure 26 shows the power consumption of the AD7851 as a function of throughput. Table VII lists the power consumption for various throughput rates.

Table VII. Power Consumption vs. Throughput

Throughput Rate	Power AD7851
1 kSPS	9 mW
2 kSPS	18 mW

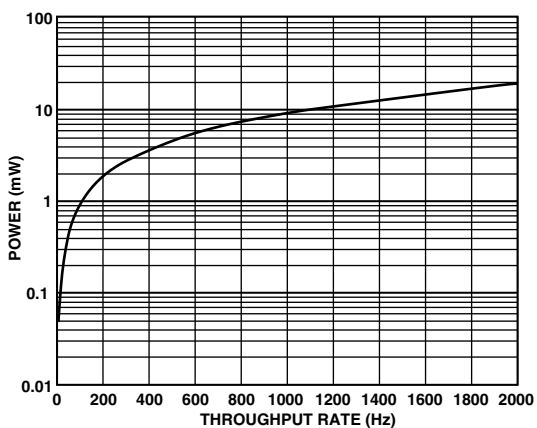

Figure 26. Power vs. Throughput AD7851

NOTE

When setting the power-down mode by writing to the part, operating in an interface mode other than Interface Modes 4 and 5 is recommended. This way the user has more control to initiate power-down and power-up commands.

CALIBRATION SECTION**Calibration Overview**

The automatic calibration that is performed on power-up ensures that the calibration options covered in this section will not be required for a significant number of applications. The user will not have to initiate a calibration unless the operating conditions change (CLKIN frequency, analog input mode, reference voltage, temperature, and supply voltages). The AD7851 has a number of calibration features that may be required in some applications, and there are a number of advantages in performing these different types of calibration. First, the internal errors in the ADC can be reduced significantly to give superior dc performance; and second, system offset and gain errors can be removed. This allows the user to remove reference errors (whether internal or external references) and to make use of the full dynamic range of the AD7851 by adjusting the analog input range of the part for a specific system.

The AD7851 has two main calibration modes: self-calibration and system calibration. There are various options in both self-calibration and system calibration as outlined previously in Table III. All the calibration functions can be initiated by pulsing the $\overline{\text{CAL}}$ pin or by writing to the control register and setting the STCAL bit to 1. The timing diagrams that follow involve using the $\overline{\text{CAL}}$ pin.

The duration of each of the different types of calibrations is given in Table VIII for the AD7851 with a 6 MHz/7 MHz master clock. These calibration times are master-clock dependent.

Table VIII. Calibration Times (AD7851 with 6 MHz CLKIN)

Type of Self- or System Calibration	Time (ms)
Full	41.7
Gain + Offset	9.26
Offset	4.63
Gain	4.63

Automatic Calibration on Power-On

The $\overline{\text{CAL}}$ pin has a 0.15 μA pull-up current source connected to it internally to allow for an automatic full self-calibration on power-on. A full self-calibration will be initiated on power-on if a 10 nF capacitor is connected from the $\overline{\text{CAL}}$ pin to DGND. The internal current source connected to the $\overline{\text{CAL}}$ pin charges up the external capacitor and the time required to charge the external capacitor will depend on the size of the capacitor itself. This time should be large enough to ensure that the internal reference is settled before the calibration is performed. However, if an external reference is being used, this reference must have stabilized before the automatic calibration is initiated (a larger capacitor on the $\overline{\text{CAL}}$ pin should be used if the external reference has not settled when the autocalibration is initiated). Once the capacitor on the $\overline{\text{CAL}}$ pin has charged, the calibration will be performed and will take 32 ms (4 MHz CLKIN). Therefore, the autocalibration should be complete before operating the part. After calibration, the part is accurate to the 12-bit level and the specifications quoted on the data sheet apply. There will be no need to perform another calibration unless the operating conditions change or unless a system calibration is required.

Self-Calibration Description

There are four different calibration options within the self-calibration mode. There is a full self-calibration where the DAC, internal offset, and internal gain errors are calibrated out; there is (Gain + Offset) self-calibration which calibrates out the internal gain error and then the internal offset errors (the internal DAC is not calibrated here); and finally, there are self-offset and self-gain calibrations that calibrate out the internal offset errors and the internal gain errors, respectively.

The internal capacitor DAC is calibrated by trimming each of the capacitors in the DAC. It is the ratio of these capacitors to each other that is critical, and so the calibration algorithm ensures that this ratio is at a specific value by the end of the calibration routine. For the offset and gain there are two separate capacitors, one of which is trimmed when an offset or gain calibration is performed. Again, it is the ratio of these capacitors to the capacitors in the DAC that is critical and the calibration algorithm ensures that this ratio is at a specified value for both the offset and gain calibrations.

In bipolar mode, the midscale error is adjusted for an offset calibration and the positive full-scale error is adjusted for the gain calibration; in unipolar mode, the zero-scale error is adjusted for an offset calibration and the positive full-scale error is adjusted for a gain calibration.

AD7851

Self-Calibration Timing

Figure 27 shows the timing for a full self-calibration. Here the BUSY line stays high for the full length of the self-calibration. A self-calibration is initiated by bringing the $\overline{\text{CAL}}$ pin low (which initiates an internal reset) and then high again or by writing to the control register and setting the STCAL bit to 1 (note that if the part is in a power-down mode, the $\overline{\text{CAL}}$ pulse width must take account of the power-up time). The BUSY line is triggered high from the rising edge of $\overline{\text{CAL}}$ (or the end of the write to the control register if calibration is initiated in the software), and BUSY will go low when the full self-calibration is complete after a time t_{CAL} .

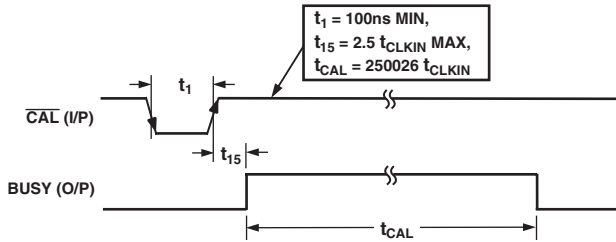

Figure 27. Timing Diagram for Full Self-Calibration

For the self-(gain + offset), self-offset, and self-gain calibrations, the BUSY line will be triggered high by the rising edge of the $\overline{\text{CAL}}$ signal (or the end of the write to the control register if calibration is initiated in the software) and will stay high for the full duration of the self-calibration. The length of time that the BUSY is high will depend on the type of self-calibration that is initiated. Typical figures are given in Table VIII. The timing diagrams for the other self-calibration options will be similar to Figure 27.

System Calibration Description

System calibration allows the user to take out system errors external to the AD7851 as well as calibrate the errors of the AD7851 itself. The maximum calibration range for the system offset errors is $\pm 5\%$ of V_{REF} and for the system gain errors is $\pm 2.5\%$ of V_{REF} . This means that the maximum allowable system offset voltage applied between the AIN(+) and AIN(-) pins for the calibration to adjust out this error is $\pm 0.05 \times V_{\text{REF}}$ (that is, the AIN(+) can be $0.05 \times V_{\text{REF}}$ above AIN(-) or $0.05 \times V_{\text{REF}}$ below AIN(-)). For the system gain error, the maximum allowable system full-scale voltage, in unipolar mode, that can be applied between AIN(+) and AIN(-) for the calibration to adjust out this error is $V_{\text{REF}} \pm 0.025 \times V_{\text{REF}}$ (that is, the AIN(+) can be $V_{\text{REF}} + 0.025 \times V_{\text{REF}}$ above AIN(-) or $V_{\text{REF}} - 0.025 \times V_{\text{REF}}$ above AIN(-)). If the system offset or system gain errors are outside the ranges mentioned, the system calibration algorithm will reduce the errors as much as the trim range allows.

Figures 28, 29, and 30 illustrate why a specific type of system calibration might be used. Figure 28 shows a system offset calibration (assuming a positive offset) where the analog input range has been shifted upwards by the system offset after the system offset calibration is completed. A negative offset may also be accounted for by a system offset calibration.

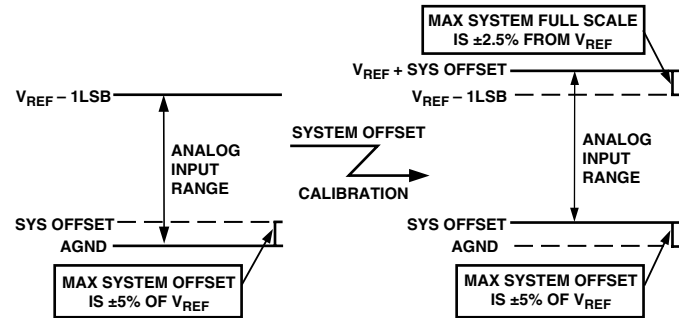

Figure 28. System Offset Calibration

Figure 29 shows a system gain calibration (assuming a system full scale greater than the reference voltage) where the analog input range has been increased after the system gain calibration is completed. A system full-scale voltage less than the reference voltage may also be accounted for by a system gain calibration.

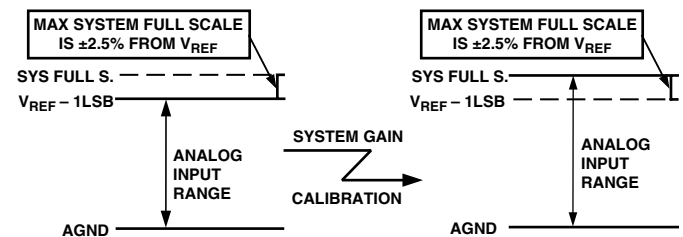

Figure 29. System Gain Calibration

Finally in Figure 30 both the system offset and gain are accounted for by the system offset followed by a system gain calibration. First the analog input range is shifted upwards by the positive system offset and then the analog input range is adjusted at the top end to account for the system full scale.

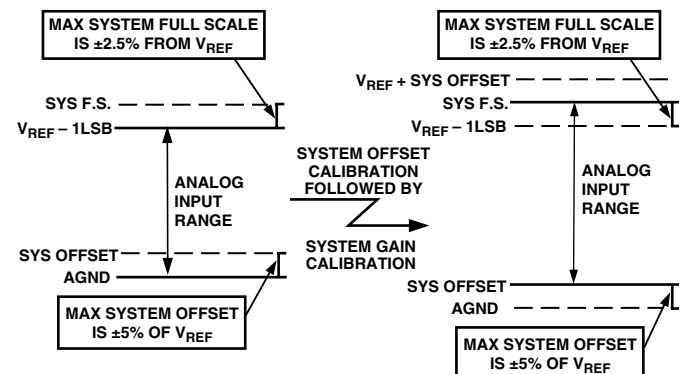

Figure 30. System (Gain + Offset) Calibration

System Gain and Offset Interaction

The inherent architecture of the AD7851 leads to an interaction between the system offset and gain errors when a system calibration is performed. Therefore, it is recommended to perform the cycle of a system offset calibration followed by a system gain calibration twice. Separate system offset and system gain calibrations reduce the offset and gain errors to at least the 14-bit level. By performing a system offset calibration first and a system gain calibration second, priority is given to reducing the gain error to zero before reducing the offset error to zero. If the system errors are small, a system offset calibration would be performed, followed by a system gain calibration. If the systems errors are large (close to the specified limits of the calibration range), this cycle would be repeated twice to ensure that the offset and gain errors were reduced to at least the 14-bit level. The advantage of doing separate system offset and system gain calibrations is that the user has more control over when the analog inputs need to be at the required levels, and the $\overline{\text{CONVST}}$ signal does not have to be used.

Alternatively, a system (gain + offset) calibration can be performed. It is recommended to perform three system (gain + offset) calibrations to reduce the offset and gain errors to the 14-bit level. For the system (gain + offset) calibration priority is given to reducing the offset error to 0 before reducing the gain error to 0. Thus, if the system errors are small then two system (gain + offset) calibrations will be sufficient. If the system errors are large (close to the specified limits of the calibration range), three system (gain + offset) calibrations may be required to reduce the offset and gain errors to at least the 14-bit level. There will never be any need to perform more than three system (offset + gain) calibrations.

In bipolar mode, the midscale error is adjusted for an offset calibration and the positive full-scale error is adjusted for the gain calibration; in unipolar mode, the zero-scale error is adjusted for an offset calibration and the positive full-scale error is adjusted for a gain calibration.

System Calibration Timing

The calibration timing diagram in Figure 31 is for a full system calibration where the falling edge of $\overline{\text{CAL}}$ initiates an internal reset before starting a calibration (note that if the part is in power-down mode the $\overline{\text{CAL}}$ pulse width must take account of the power-up time). If a full system calibration is performed in the software, it is easier to perform separate gain and offset calibrations so that the $\overline{\text{CONVST}}$ bit in the control register does not have to be programmed in the middle of the system calibration sequence. The rising edge of $\overline{\text{CAL}}$ starts calibration of the internal DAC and causes the $\overline{\text{BUSY}}$ line to go high. If the control register is set for a full system calibration, the $\overline{\text{CONVST}}$ must be used also. The full-scale system voltage should be applied to the analog input pins from the start of calibration. The $\overline{\text{BUSY}}$ line will go low once the DAC and system gain calibration are complete.

Next, the system offset voltage is applied to the AIN pin for a minimum setup time (t_{SETUP}) of 100 ns before the rising edge of the $\overline{\text{CONVST}}$ and remains until the $\overline{\text{BUSY}}$ signal goes low. The rising edge of the $\overline{\text{CONVST}}$ starts the system offset calibration section of the full system calibration and also causes the $\overline{\text{BUSY}}$ signal to go high. The $\overline{\text{BUSY}}$ signal will go low after a time t_{CAL2} when the calibration sequence is complete.

The timing for a system (gain + offset) calibration is very similar to that of Figure 31, the only difference being that the time t_{CAL1} will be replaced by a shorter time of the order of t_{CAL2} as the internal DAC will not be calibrated. The $\overline{\text{BUSY}}$ signal will signify when the gain calibration is finished and when the part is ready for the offset calibration.

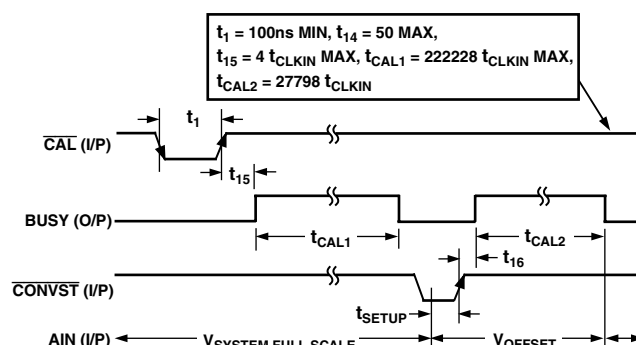

Figure 31. Timing Diagram for Full System Calibration

The timing diagram for a system offset or system gain calibration is shown in Figure 32. Here again the $\overline{\text{CAL}}$ is pulsed and the rising edge of the $\overline{\text{CAL}}$ initiates the calibration sequence (or the calibration can be initiated in software by writing to the control register). The rising edge of the $\overline{\text{CAL}}$ causes the $\overline{\text{BUSY}}$ line to go high and it will stay high until the calibration sequence is finished. The analog input should be set at the correct level for a minimum setup time (t_{SETUP}) of 100 ns before the rising edge of $\overline{\text{CAL}}$ and stay at the correct level until the $\overline{\text{BUSY}}$ signal goes low.

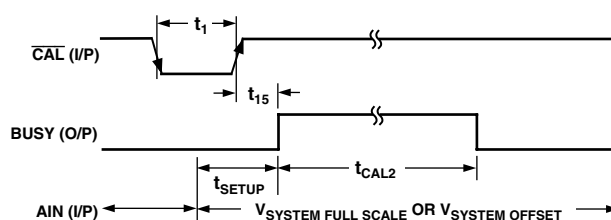

Figure 32. Timing Diagram for System Gain or System Offset Calibration

AD7851

SERIAL INTERFACE SUMMARY

Table IX details the five interface modes and the serial clock edges from which the data is clocked out by the AD7851 (DOUT edge) and that the data is latched in on (DIN edge). The logic level of the POLARITY pin is shown and it is clear that this reverses the edges.

In Interface Modes 4 and 5 the $\overline{\text{SYNC}}$ always clocks out the first data bit and SCLK will clock out the subsequent bits.

In Interface Modes 1, 2, and 3 the $\overline{\text{SYNC}}$ is gated with the SCLK and the POLARITY pin. Thus, the $\overline{\text{SYNC}}$ may clock out the MSB of data. Subsequent bits will be clocked out by the serial clock, SCLK. The conditions for the $\overline{\text{SYNC}}$ clocking out the MSB of data is as follows.

With the POLARITY pin high, the falling edge of $\overline{\text{SYNC}}$ will clock out the MSB if the serial clock is low when the $\overline{\text{SYNC}}$ goes low.

With the POLARITY pin low, the falling edge of $\overline{\text{SYNC}}$ will clock out the MSB if the serial clock is high when the $\overline{\text{SYNC}}$ goes low.

Table IX. SCLK Active Edge for Different Interface Modes

Interface Mode	POLARITY Pin	DOUT Edge	DIN Edge
1, 2, 3	0 1	SCLK \uparrow SCLK \downarrow	SCLK \downarrow SCLK \uparrow
4, 5	0 1	SCLK \downarrow SCLK \uparrow	SCLK \uparrow SCLK \downarrow

Resetting the Serial Interface

When writing to the part via the DIN line there is the possibility of writing data into the incorrect registers, such as the test register for instance, or writing the incorrect data and corrupting the serial interface. The $\overline{\text{SYNC}}$ pin acts as a reset. Bringing the $\overline{\text{SYNC}}$ pin high resets the internal shift register. The first data bit after the next $\overline{\text{SYNC}}$ falling edge will now be the first bit of a new 16-bit transfer. It is also possible that the test register contents were altered when the interface was lost. Therefore, once the serial interface is reset, it may be necessary to write the 16-bit word 0100 0000 0000 0010 to restore the test register to its default value. Now the part and serial interface are completely reset. It is always useful to retain the ability to program the $\overline{\text{SYNC}}$ line from a port of the $\mu\text{Controller/DSP}$ to have the ability to reset the serial interface.

Table X summarizes the interface modes provided by the AD7851. It also outlines the various $\mu\text{P}/\mu\text{C}$ to which the particular interface is suited.

The interface mode is determined by the serial mode selection Pins SM1 and SM2. Interface Mode 2 is the default mode. Note that Interface Mode 1 and 2 have the same combination of

SM1 and SM2. Interface Mode 1 may only be set by programming the control register (see the Control Register section). External SCLK and $\overline{\text{SYNC}}$ signals ($\overline{\text{SYNC}}$ may be hardwired low) are required for Interfaces Modes 1, 2, and 3. In Interface Modes 4 and 5, the AD7851 generates the SCLK and $\overline{\text{SYNC}}$.

Some of the more popular $\mu\text{Processors}$, $\mu\text{Controllers}$, and the DSP machines that the AD7851 will interface to directly are mentioned here. This does not cover all μCs , μPs , and DSPs. The interface mode of the AD7851 that is mentioned here for a specific μC , μP , or DSP is only a guide and in most cases another interface mode may work just as well.

A more detailed timing description on each of the interface modes follows.

Table X. Interface Mode Description

SM1 Pin	SM2 Pin	$\mu\text{Processor}$ $\mu\text{Controller}$	Interface Mode
0	0	8XC51 8XL51 PIC17C42	1 (2-Wire) DIN Is an Input/ Output Pin
0	0	68HC11 68L11	2 (3-Wire, SPI/QSPI) Default Mode
0	1	68HC16 PIC16C64 ADSP-21xx DSP56000 DSP56001 DSP56002 DSP56L002 TMS320C30	3 (QSPI) External Serial Clock, SCLK, and External Frame Sync, $\overline{\text{SYNC}}$ Are Required
1	0	68HC16	4 (DSP Is Slave) AD7851 Generates a Noncontinuous (16 Clocks) Serial Clock, SCLK, and the Frame Sync, $\overline{\text{SYNC}}$
1	1	ADSP-21xx DSP56000 DSP56001 DSP56002 DSP56L002 TMS320C20 TMS320C25 TMS320C30 TMS320C5X TMS320LC5X	5 (DSP Is Slave) AD7851 Generates a Continuous Serial Clock, SCLK, and the Frame Sync, $\overline{\text{SYNC}}$

DETAILED TIMING SECTION

Mode 1 (2-Wire 8051 Interface)

The read and write takes place on the DIN line and the conversion is initiated by pulsing the $\overline{\text{CONVST}}$ pin (note that in every write cycle the $2/3$ MODE bit must be set to 1). The conversion may be started by setting the $\overline{\text{CONVST}}$ bit in the control register to 1 instead of using the CONVST line.

Below in Figure 33 and in Figure 34 are the timing diagrams for Interface Mode 1 in the 2-wire interface mode. Here the DIN pin is used for both input and output as shown. The $\overline{\text{SYNC}}$ input is level-triggered active low and can be pulsed (Figure 33) or can be constantly low (Figure 34).

In Figure 33, the part samples the input data on the rising edge of SCLK. After the 16th rising edge of SCLK, the DIN is configured as an output. When the $\overline{\text{SYNC}}$ is taken high, the DIN is three-stated. Taking $\overline{\text{SYNC}}$ low disables the three-state on the DIN pin and the first SCLK falling edge clocks out the first data bit. Once the 16 clocks have been provided, the DIN pin will automatically revert back to an input after a time t_{14} . Note that a

continuous SCLK shown by the dotted waveform in Figure 33 can be used provided the $\overline{\text{SYNC}}$ is low for only 16 clock pulses in each of the read and write cycles. The POLARITY pin may be used to change the SCLK edge which the data is sampled on and clocked out on.

In Figure 34, the $\overline{\text{SYNC}}$ line is tied low permanently, which results in a different timing arrangement. With $\overline{\text{SYNC}}$ tied low permanently, the DIN pin will never be three-stated. The 16th rising edge of SCLK configures the DIN pin as an input or an output as shown in the diagram. Here no more than 16 SCLK pulses must occur for each of the read and write operations.

If reading from and writing to the calibration registers in this interface mode, all the selected calibration registers must be read from or written to. The read and write operations cannot be aborted. When reading from the calibration registers, the DIN pin will remain as an output for the full duration of all the calibration register read operations. When writing to the calibration registers, the DIN pin will remain as an input for the full duration of all the calibration register write operations.

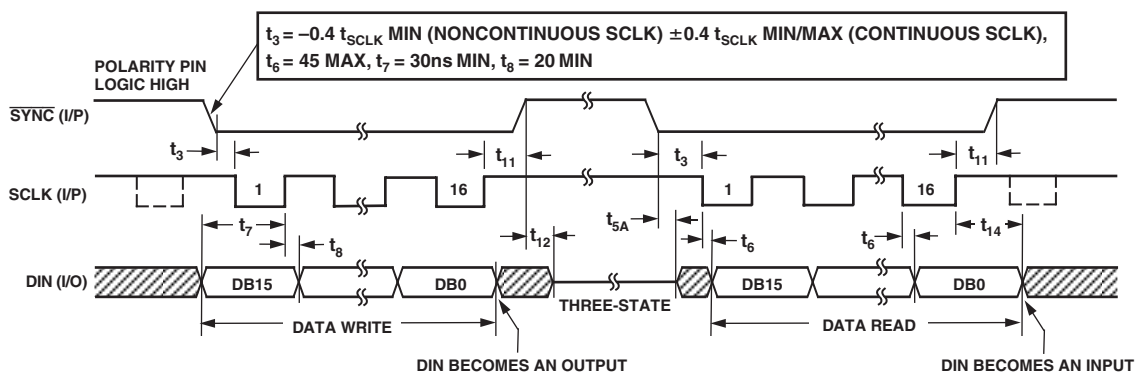

Figure 33. Timing Diagram for Read/Write Operation with DIN as an Input/Output (Interface Mode 1, SM1 = SM2 = 0)

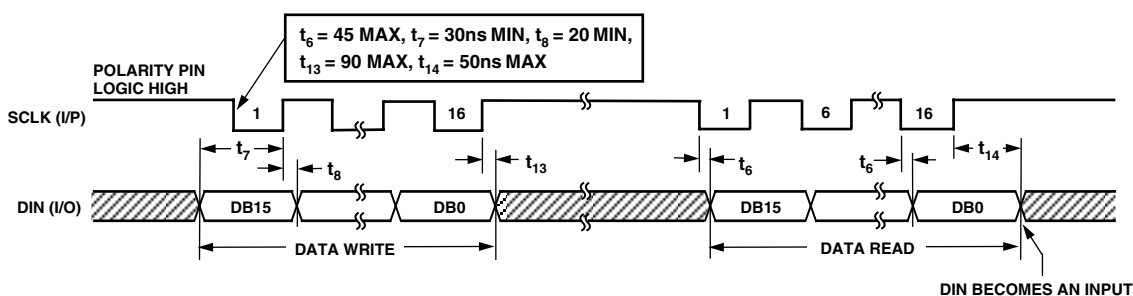

Figure 34. Timing Diagram for Read/Write Operation with DIN as an Input/Output and $\overline{\text{SYNC}}$ Input Tied Low (Interface Mode 1, SM1 = SM2 = 0)

Mode 2 (3-Wire SPI/QSPI Interface Mode)

Default Interface Mode

Figure 35 shows the timing diagram for Interface Mode 2 which is the SPI/QSPI interface mode. Here the $\overline{\text{SYNC}}$ input is active low and may be pulsed or tied permanently low. If $\overline{\text{SYNC}}$ is permanently low, 16 clock pulses must be applied to the SCLK pin for the part to operate correctly, and with a pulsed $\overline{\text{SYNC}}$ input a continuous SCLK may be applied provided $\overline{\text{SYNC}}$ is low for only 16 SCLK cycles. In Figure 35, the $\overline{\text{SYNC}}$ going low disables the three-state on the DOUT pin. The first falling edge of the SCLK after the $\overline{\text{SYNC}}$ going low clocks out the first leading zero on the DOUT pin. The DOUT pin is three-stated again a time t_{12} after the $\overline{\text{SYNC}}$ goes high. With the DIN pin, the data input has to be set up a time t_7 before the SCLK rising edge as the part samples the input data on the SCLK rising edge in this case. The POLARITY pin may be used to change the SCLK edge which the data is sampled on and clocked out on. If resetting the interface is required, the $\overline{\text{SYNC}}$ must be taken high and then low.

Mode 3 (QSPI Interface Mode)

Figure 36 shows the timing diagram for Interface Mode 3. In this mode, the DSP is the master and the part is the slave. Here the $\overline{\text{SYNC}}$ input is edge triggered from high to low, and the 16 clock pulses are counted from this edge. Because the clock pulses are counted internally, the $\overline{\text{SYNC}}$ signal does not have to go high after the 16th SCLK rising edge as shown by the dotted $\overline{\text{SYNC}}$ line. Thus a frame sync that gives a high pulse of one SCLK cycle minimum duration at the beginning of the read/write operation may be used. The rising edge of $\overline{\text{SYNC}}$ enables the three-state on the DOUT pin. The falling edge of $\overline{\text{SYNC}}$ disables the three-state on the DOUT pin, and data is clocked out on the falling edge of SCLK. Once $\overline{\text{SYNC}}$ goes high, the three-state on the DOUT pin is enabled. The data input is sampled on the rising edge of SCLK and thus has to be valid a time t_7 before this rising edge. The POLARITY pin may be used to change the SCLK edge which the data is sampled on and clocked out on. If resetting the interface is required, the $\overline{\text{SYNC}}$ must be taken high and then low.

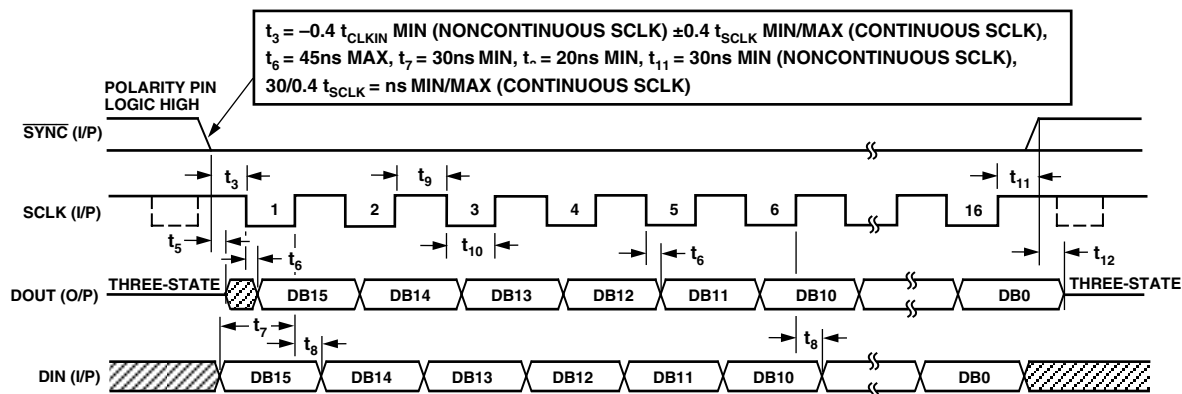

Figure 35. SPI/QSPI Mode 2 Timing Diagram for Read/Write Operation with DIN Input, DOUT Output, and $\overline{\text{SYNC}}$ Input ($SM1 = SM2 = 0$)

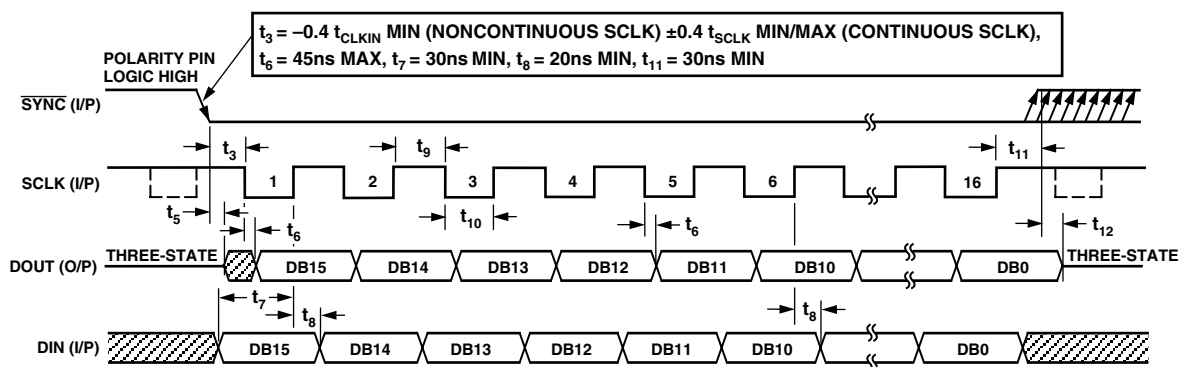

Figure 36. QSPI Mode 3 Timing Diagram for Read/Write Operation with $\overline{\text{SYNC}}$ Input Edge Triggered ($SM1 = 0, SM2 = 1$)

MODE 4 and 5 (Self-Clocking Modes)

The timing diagrams in Figure 38 and Figure 39 are for Interface Modes 4 and 5. Interface Mode 4 has a noncontinuous SCLK output and Interface Mode 5 has a continuous SCLK output (SCLK is switched off internally during calibration for both Modes 4 and 5). These modes of operation are especially different from all the other modes because the SCLK and SYNC are outputs. The SYNC is generated by the part as is the SCLK. The master clock at the CLKIN pin is routed directly to the SCLK pin for Interface Mode 5 (continuous SCLK) and the CLKIN signal is gated with the SYNC to give the SCLK (non-continuous) for Interface Mode 4.

The most important point about these two modes of operation is that the result of the current conversion is clocked out during the same conversion and a write to the part during this conversion is for the next conversion. The arrangement is shown in Figure 37. Figure 38 and Figure 39 show more detailed timing for the arrangement of Figure 37.

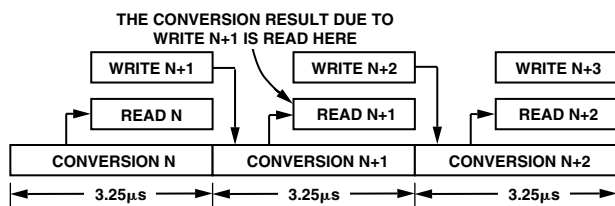

Figure 37.

In Figure 38 the first point to note is that the BUSY, SYNC, and SCLK are all outputs from the AD7851 with the CONVST being the only input signal. Conversion is initiated with the CONVST signal going low. This CONVST falling edge also triggers the BUSY to go high. The CONVST signal rising edge triggers the SYNC to go low after a short delay ($2.5 t_{CLKIN}$ to $3.5 t_{CLKIN}$ typically) after which the SCLK will clock out the data on the DOUT pin during conversion. The data on the DIN pin is also clocked in to the AD7851 by the same SCLK for the next conversion. The read/write operations must be complete after 16 clock cycles (which takes $3.25 \mu s$ approximately from the rising edge of CONVST assuming a 6 MHz CLKIN). At

this time, the conversion will be complete, the SYNC will go high, and the BUSY will go low. The next falling edge of the CONVST must occur at least 330 ns after the falling edge of BUSY to allow the track-and-hold amplifier adequate acquisition time as shown in Figure 38. This gives a throughput time of $3.68 \mu s$. The maximum throughput rate in this case is 272 kHz.

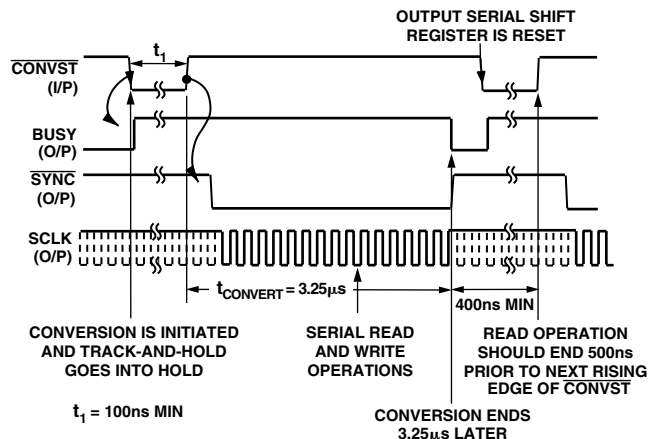

Figure 38. Mode 4 and 5 Timing Diagram ($SM1 = 1$, $SM2 = 1$ and 0)

In these interface modes, the part is now the master and the DSP is the slave. Figure 39 is an expansion of Figure 38. The AD7851 will ensure SYNC goes low after the rising edge C of the continuous SCLK (Interface Mode 5) in Figure 39. Only in the case of a noncontinuous SCLK (Interface Mode 4) will the time t_4 apply. The first data bit is clocked out from the falling edge of SYNC. The SCLK rising edge clocks out all subsequent bits on the DOUT pin. The input data present on the DIN pin is clocked in on the rising edge of the SCLK. The POLARITY pin may be used to change the SCLK edge which the data is sampled on and clocked out on. The SYNC will go high after the 16th SCLK rising edge and before the falling edge D of the continuous SCLK in Figure 39. This ensures the part will not clock in an extra bit from the DIN pin or clock out an extra bit on the DOUT pin.

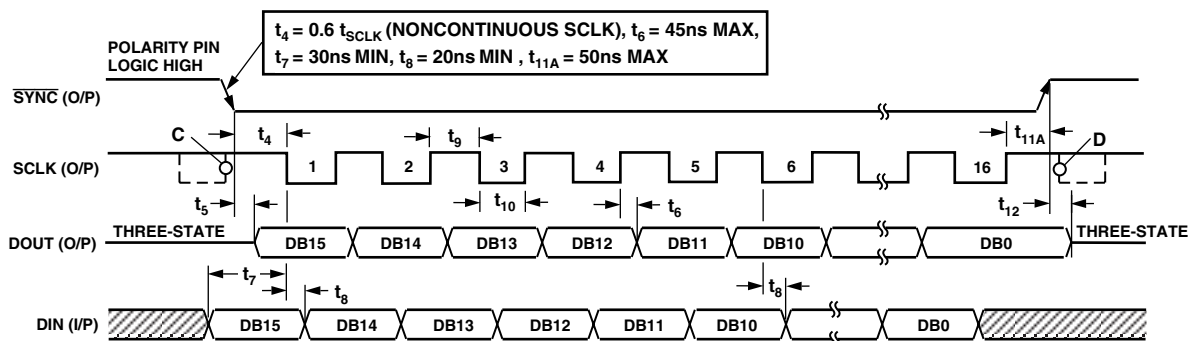

Figure 39. Mode 4 and 5 Timing Diagram for Read/Write with SYNC Output and SCLK Output (Continuous and Noncontinuous, $SM1 = 1$, $SM2 = 1$ and 0)

AD7851

If the user has control of the $\overline{\text{CONVST}}$ pin but does not want to exercise it for every conversion, the control register may be used to start a conversion. Setting the $\overline{\text{CONVST}}$ bit in the control register to 1 starts a conversion. If the user does not have control of the $\overline{\text{CONVST}}$ pin, a conversion should not be initiated by writing to the control register. The reason for this is that the user may get locked out and not be able to perform any further write/read operations. When a conversion is started by writing to the control register, the $\overline{\text{SYNC}}$ goes low and read/write operations take place while the conversion is in progress. However, once the conversion is complete, there is no way of writing to the part unless the $\overline{\text{CONVST}}$ pin is exercised. The $\overline{\text{CONVST}}$ signal triggers the $\overline{\text{SYNC}}$ signal low which allows read/write operations to take place. $\overline{\text{SYNC}}$ must be low to perform read/write operations. The $\overline{\text{SYNC}}$ is triggered low by the $\overline{\text{CONVST}}$ signal rising edge or by setting the $\overline{\text{CONVST}}$ bit in the control register to 1. Therefore, if there is not full control of the $\overline{\text{CONVST}}$ pin, the user may become locked out.

CONFIGURING THE AD7851

AD7851 as a Read-Only ADC

The AD7851 contains 14 on-chip registers that can be accessed via the serial interface. In the majority of applications, it will not be necessary to access all of these registers. Figure 40 outlines the sequence used to configure the AD7851 as a read-only ADC. In this case, there is no writing to the on-chip registers and only the conversion result data is read from the part. Interface Mode 1 cannot be used in this case as it is necessary to write to the control register to set Interface Mode 1. Here the CLKIN signal is applied directly after power-on; the CLKIN signal must be present to allow the part to perform a calibration. This automatic calibration will be completed approximately 42 ms after the AD7851 has powered up (6 MHz CLK).

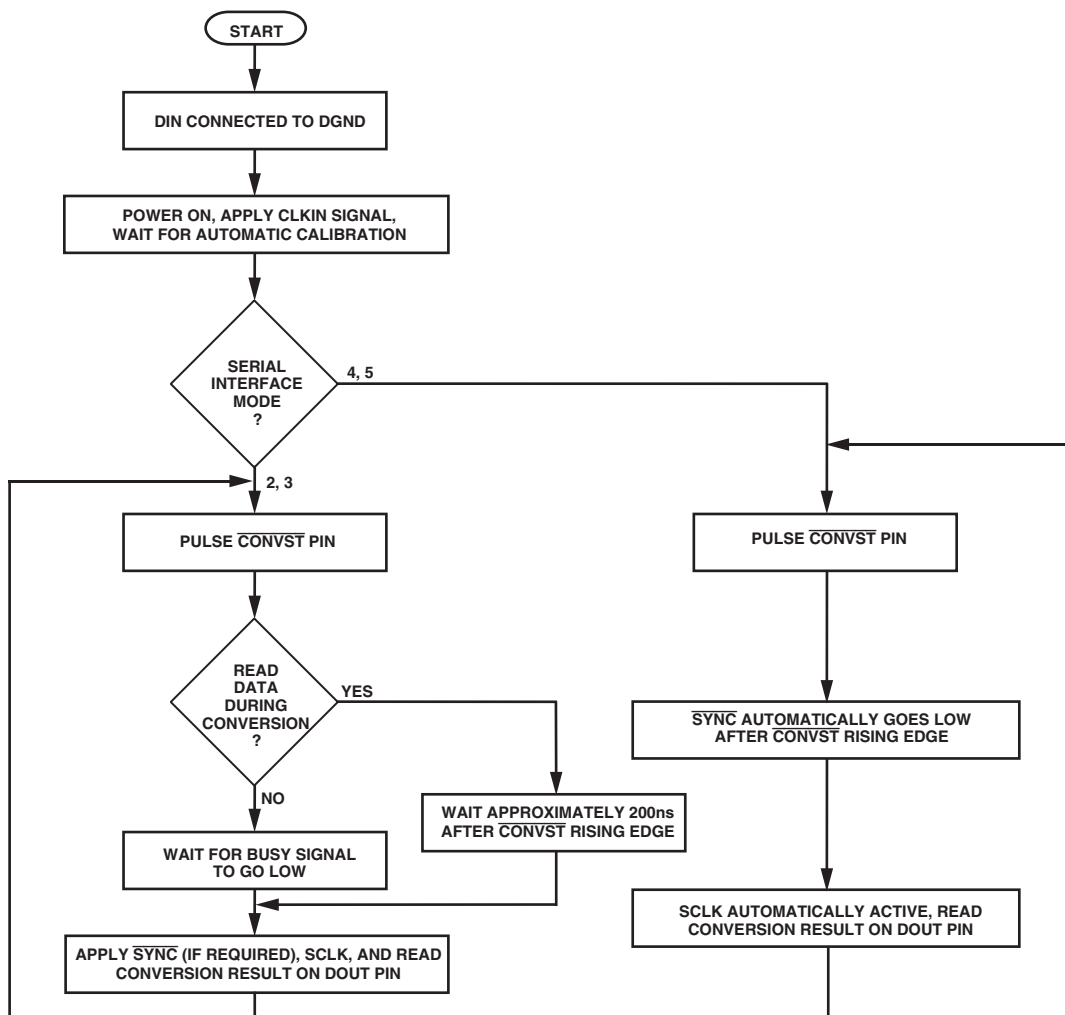

Figure 40. Flowchart for Setting Up and Reading from the AD7851

Writing to the AD7851

For accessing the on-chip registers, it is necessary to write to the part. To enable Serial Interface Mode 1, the user must also write to the part. Figures 41, 42, and 43 shows how to configure the AD7851 for each of the different serial interface modes. The continuous loops on all diagrams indicate the sequence for more than one conversion. The options of using a hardware (pulsing the $\overline{\text{CONVST}}$ pin) or software (setting the $\overline{\text{CONVST}}$ bit to 1) conversion start, and reading/writing during or after conversion are shown in Figures 41 and 42. If the $\overline{\text{CONVST}}$ pin is never used, then it should be tied to DV_{DD} permanently. Where refer-

ence is made to the BUSY bit equal to a Logic 0, to indicate the end of conversion, the user in this case would poll the BUSY bit in the status register.

Interface Modes 2 and 3 Configuration

Figure 41 shows the flowchart for configuring the part in Interface Modes 2 and 3. For these interface modes, the read and write operations take place simultaneously via the serial port. Writing all 0s ensures that no valid data is written to any of the registers. When using the software conversion start and transferring data during conversion, the Figure 41 note must be obeyed.

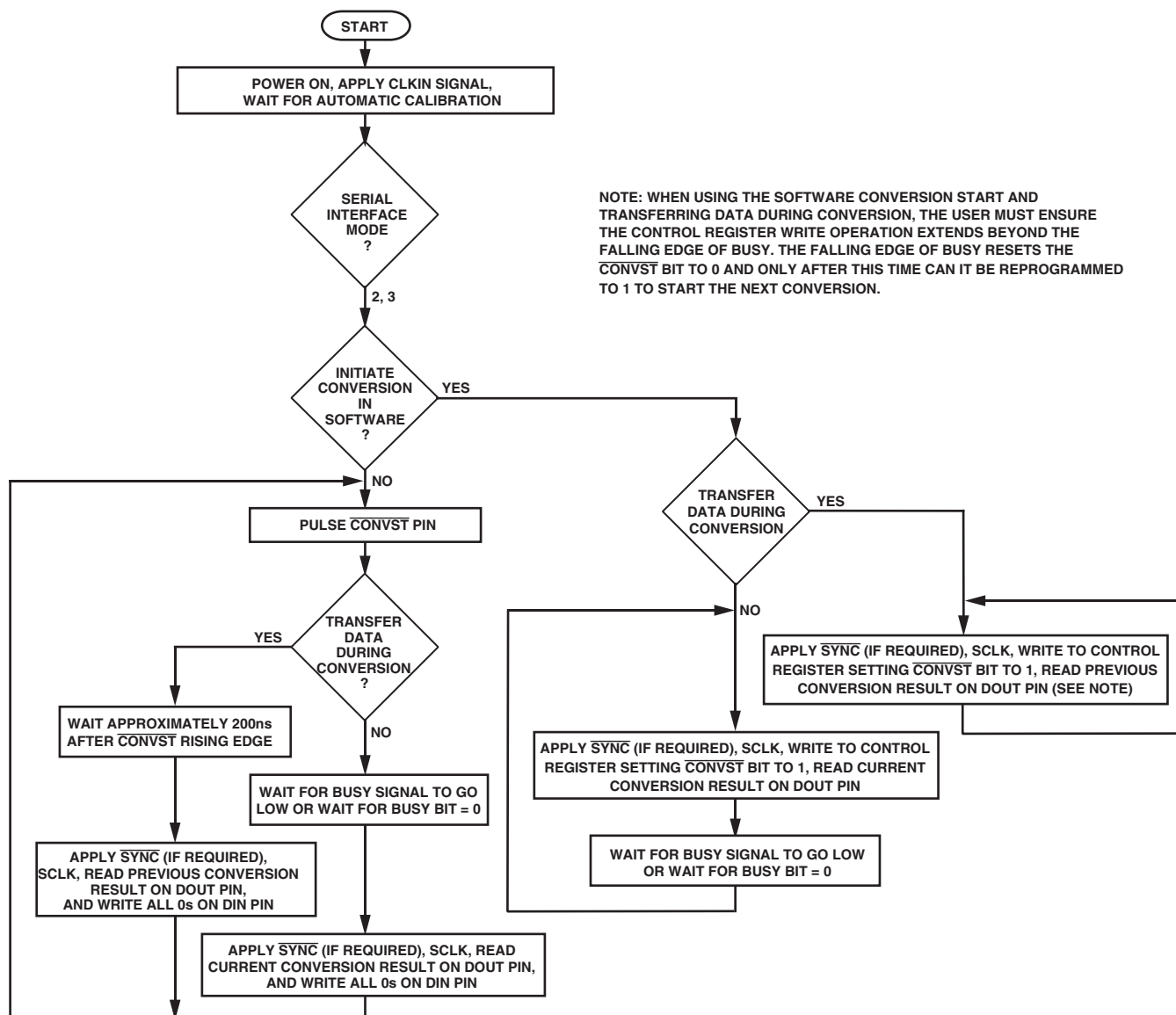

Figure 41. Flowchart for Setting Up, Reading, and Writing in Interface Modes 2 and 3

AD7851

Interface Mode 1 Configuration

Figure 42 shows the flowchart for configuring the part in Interface Mode 1. This mode of operation can only be enabled by writing to the control register and setting the $2/3$ MODE bit. Reading and writing cannot take place simultaneously in this mode as the DIN pin is used for both reading and writing.

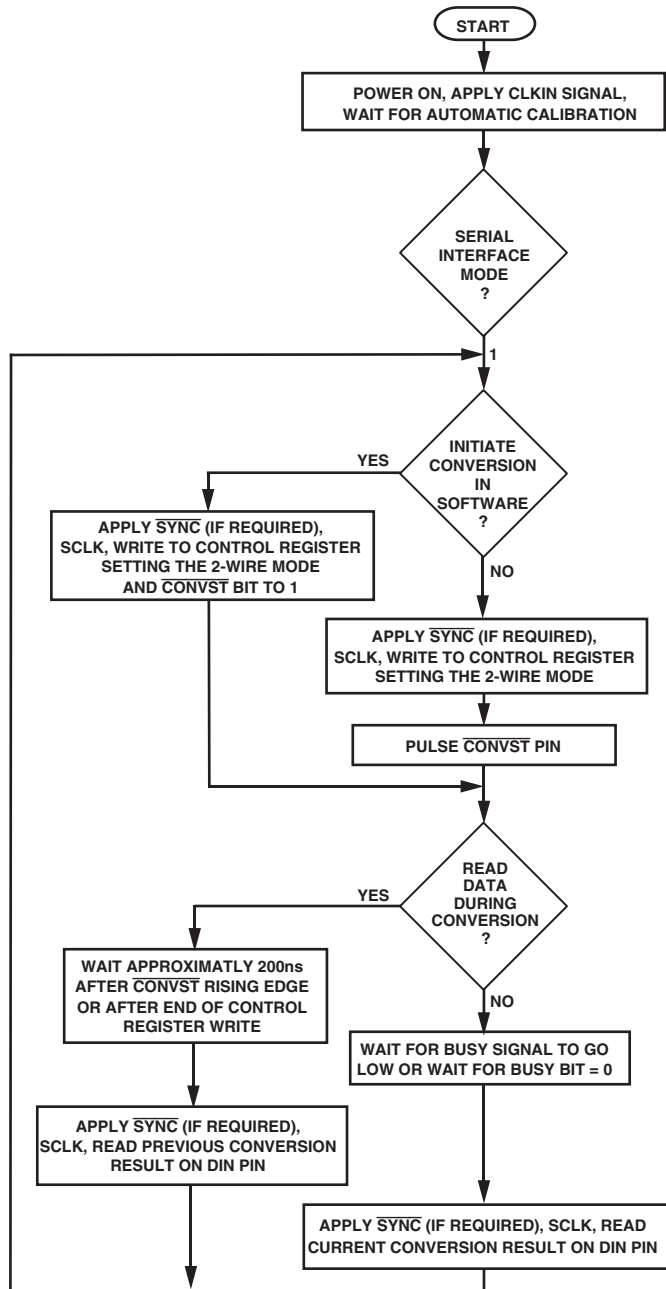

Figure 42. Flowchart for Setting Up, Reading, and Writing in Interface Mode 1

Interface Modes 4 and 5 Configuration

Figure 43 shows the flowchart for configuring the AD7851 in Interface Modes 4 and 5, the self-clocking modes. In this case, it is not recommended to use the software conversion start option. The read and write operations always occur simultaneously and during conversion.

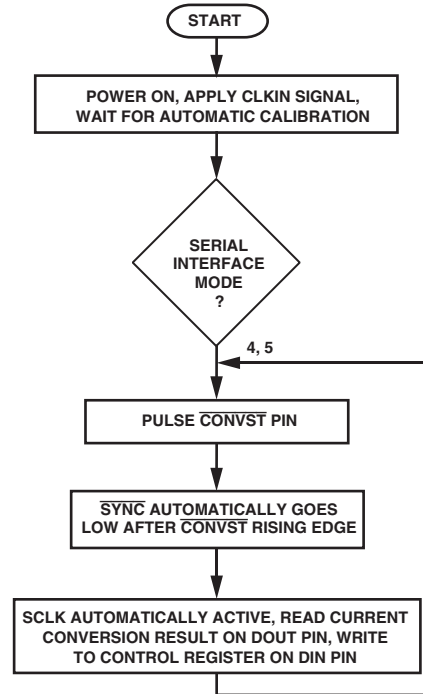

Figure 43. Flowchart for Setting Up, Reading, and Writing in Interface Modes 4 and 5

MICROPROCESSOR INTERFACING

In many applications, the user may not require the facility of writing to the on-chip registers. The user may just want to hardwire the relevant pins to the appropriate levels and read the conversion result. In this case, the DIN pin can be tied low so that the on-chip registers are never used. Now the part will operate as a nonprogrammable analog-to-digital converter where the $\overline{\text{CONVST}}$ is applied, a conversion is performed, and the result may be read using the SCLK to clock out the data from the output register on to the DOUT pin. Note that the DIN pin cannot be tied low when using the 2-wire interface mode of operation.

The SCLK can also be connected to the CLKIN pin if the user does not want to have to provide separate serial and master clocks in Interface Modes 1, 2, and 3. With this arrangement, the $\overline{\text{SYNC}}$ signal must be low for 16 SCLK cycles in Interface Modes 1 and 2 for the read and write operations. For Interface Mode 3, the $\overline{\text{SYNC}}$ can be low for more than 16 SCLK cycles for the read and write operations. Note that in Interface Modes 4 and 5 the CLKIN and SCLK cannot be tied together as the SCLK is an output and the CLKIN is an input.

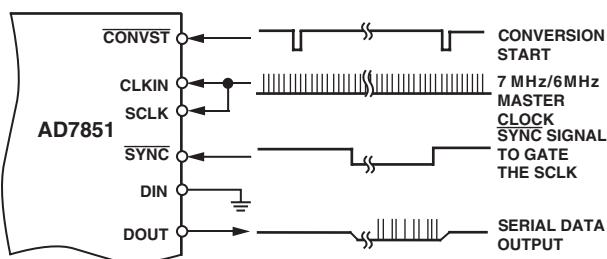

Figure 44. Simplified Interface Diagram with DIN Grounded and SCLK Tied to CLKIN

AD7851 to 8XC51/PIC17C42 Interface

Figure 45 shows the AD7851 interface to the 8XC51/PIC17C42, which only runs at 5 V. The 8XC51 is in Mode 0 operation. This is a 2-wire interface consisting of the SCLK and the DIN which acts as a bidirectional line. The $\overline{\text{SYNC}}$ is tied low. The BUSY line can be used to give an interrupt driven system but this would not normally be the case with the 8XC51/PIC17C42. For the 8XC51, 12 MHz version, the serial clock will run at a maximum of 1 MHz so that the serial interface to the AD7851 will only be running at 1 MHz. The CLKIN signal must be provided separately to the AD7851 from a port line on the 8XC51 or from a source other than the 8XC51. Here the SCLK cannot be tied to the CLKIN as the 8XC51 only provides a noncontinuous serial clock. The $\overline{\text{CONVST}}$ signal can be provided from an external timer or conversion can be started in software if required. The sequence of events would typically be writing to the control register via the DIN line setting a conversion start and at the same time reading data from the previous conversion on the DOUT line, wait for the conversion to be finished (3.25 μs with 6 MHz CLKIN), and then repeat the sequence. The maximum serial frequency will be determined by the data access and hold times of the 8XC51/PIC17C42 and the AD7851.

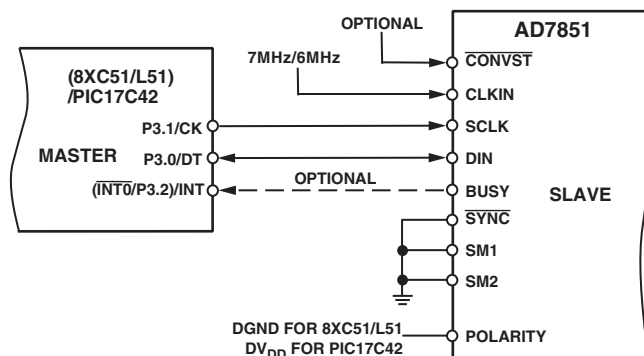

Figure 45. 8XC51/PIC17C42 Interface

AD7851 to 68HC11/16/L11/PIC16C42 Interface

Figure 46 shows the AD7851 SPI/QSPI interface to the 68HC11/16/L11/PIC16C42. The $\overline{\text{SYNC}}$ line is not used and is tied to DGND. The $\mu\text{Controller}$ is configured as the master by setting the MSTR bit in the SPCR to 1, and thus provides the serial clock on the SCK pin. For all the $\mu\text{Controllers}$, the CPOL bit is set to 1, and for the 68HC11/16/L11, the CPHA bit is set to 1. The CLKIN and $\overline{\text{CONVST}}$ signals can be supplied from the $\mu\text{Controller}$ or from separate sources. The BUSY signal can be used as an interrupt to tell the $\mu\text{Controller}$ when the conversion is finished, then the reading and writing can take place. If required, the reading and writing can take place during conversion and there will be no need for the BUSY signal in this case. For no writing to the part then the DIN pin can be tied permanently low. For the 68HC16 and the QSPI interface, the SM2 pin should be tied high and the $\overline{\text{SS}}$ line tied to the SYNC pin. The microsequencer on the 68HC16 QSPI port can be used for performing a number of read and write operations independent of the CPU and storing the conversion results in memory without taxing the CPU. The typical sequence of events would be writing to the control register via the DIN line setting a conversion start and at the same time reading data from the previous conversion on the DOUT line, wait for the conversion to be finished (3.25 μs with 6 MHz CLKIN), and then repeat the sequence. The maximum serial frequency will be determined by the data access and hold times of the $\mu\text{Controllers}$ and the AD7851.

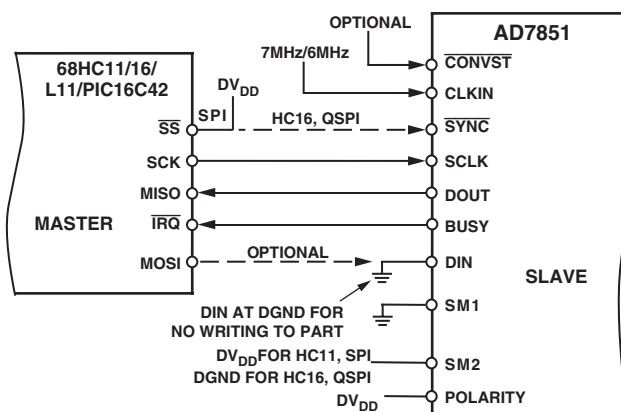

Figure 46. 68HC11 and 68HC16 Interface

AD7851

AD7851 to ADSP-21xx Interface

Figure 47 shows the AD7851 interface to the ADSP-21xx. The ADSP-21xx is the slave and the AD7851 is the master. The AD7851 is in Interface Mode 5. For the ADSP-21xx, the bits in the serial port control register should be set up as TFSR = RFSR = 1 (need a frame sync for every transfer), SLEN = 15 (16-bit word length), TFSW = RFSW = 1 (alternate framing mode for transmit and receive operations), INVRFS = INVTFS = 1 (active low RFS and TFS), IRFS = ITFS = 0 (external RFS and TFS), and ISCLK = 0 (external serial clock). The CLKIN and CONVST signals could be supplied from the ADSP-21xx or from an external source. The AD7851 supplies the SCLK and the SYNC signals to the ADSP-21xx and the reading and writing takes place during conversion. The BUSY signal only indicates when the conversion is finished and may not be required. The data access and hold times of the ADSP-21xx and the AD7851 allow for a CLKIN of 7 MHz/6 MHz with a 5 V supply.

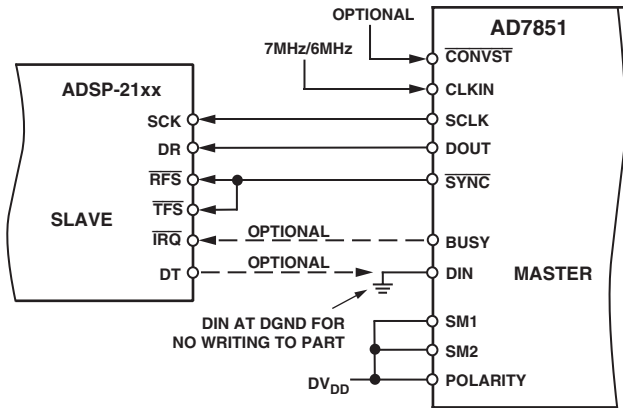

Figure 47. ADSP-21xx Interface

AD7851 to DSP56000/1/2/L002 Interface

Figure 48 shows the AD7851 to DSP56000/1/2/L002 interface. Here the DSP5600x is the master and the AD7851 is the slave. The AD7851 is in Interface Mode 3. The setting of the bits in the registers of the DSP5600x would be for synchronous operation (SYN = 1), internal frame sync (SCD2 = 1), internal clock (SCKD = 1), 16-bit word length (WL1 = 1, WL0 = 0), frames sync only active at beginning of the transfer (FSL1 = 0, FSL0 = 1). A gated clock can be used (GCK = 1) or if the SCLK is to be tied to the CLKIN of the AD7851, then there must be a continuous clock (GCK = 0). Again the data access and hold times of the DSP5600x and the AD7851 should allow for an SCLK of 7 MHz/6 MHz.

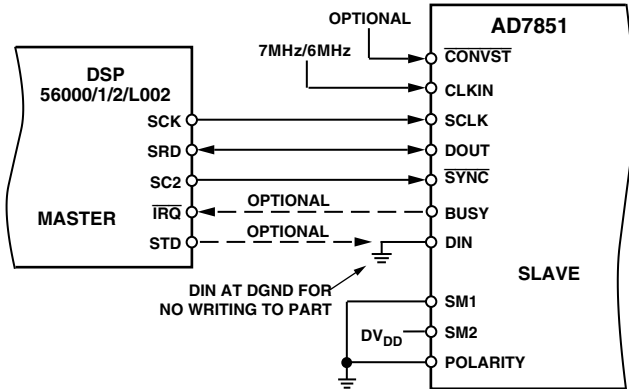

Figure 48. DSP56000/1/2/L002 Interface

AD7851 to TMS320C20/25/5x/LC5x Interface

Figure 49 shows the AD7851 to the TMS320Cxx interface. The AD7851 is the master and operates in Interface Mode 5. For the TMS320Cxx, the CLKX, CLKR, FSX, and FSR pins should all be configured as inputs. The CLKX and the CLKR should be connected together as should the FSX and FSR. Because the AD7851 is the master and the reading and writing occurs during the conversion, the BUSY only indicates when the conversion is finished and thus may not be required. Again the data access and hold times of the TMS320Cxx and the AD7851 allow for a CLKIN of 7 MHz/6 MHz.

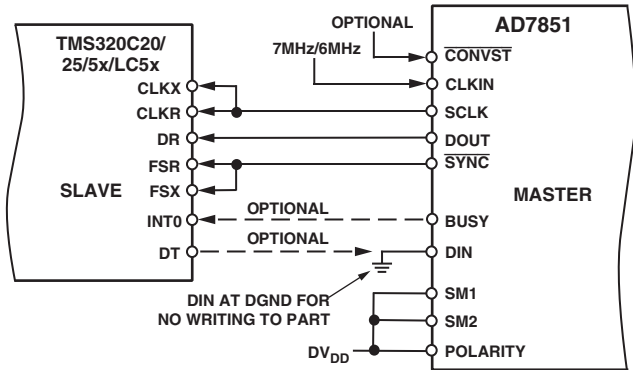

Figure 49. TMS320C20/25/5x Interface

APPLICATION HINTS

Grounding and Layout

The analog and digital supplies to the AD7851 are independent and separately pinned out to minimize coupling between the analog and digital sections of the device. The part has very good immunity to noise on the power supplies as can be seen by the PSRR versus frequency graph. However, care should still be taken with regard to grounding and layout.

The printed circuit board that houses the AD7851 should be designed such that the analog and digital sections are separated and confined to certain areas of the board. This facilitates the use of ground planes that can be separated easily. A minimum etch technique is generally best for ground planes as it gives the best shielding. Digital and analog ground planes should only be joined in one place. If the AD7851 is the only device requiring an AGND to DGND connection, then the ground planes should be connected at the AGND and DGND pins of the AD7851. If the AD7851 is in a system where multiple devices require AGND to DGND connections, the connection should still be made at one point only, a star ground point which should be established as close as possible to the AD7851.

Avoid running digital lines under the device as these will couple noise onto the die. The analog ground plane should be allowed to run under the AD7851 to avoid noise coupling. The power supply lines to the AD7851 should use as large a trace as possible to provide low impedance paths and reduce the effects of glitches on the power supply line. Fast switching signals like clocks should be shielded with digital ground to avoid radiating noise to other sections of the board and clock signals should never be run near the analog inputs. Avoid crossover of digital and analog signals. Traces on opposite sides of the board should run at right angles to each other. This will reduce the effects of feedthrough through the board. A microstrip technique is by far the best but is not always possible with a double-sided board. In this technique, the component side of the board is dedicated to ground planes while signals are placed on the solder side.

Good decoupling is also important. All analog supplies should be decoupled with 10 μF tantalum in parallel with 0.1 μF capacitors to AGND. All digital supplies should have a 0.1 μF disc ceramic capacitor to DGND. To achieve the best from these decoupling components, they must be placed as close as possible to the device, ideally right up against the device. In systems where a common supply voltage is used to drive both the AV_{DD} and DV_{DD} of the AD7851, it is recommended that the system's AV_{DD} supply is used. In this case, there should be a 10 Ω resistor between the AV_{DD} pin and DV_{DD} pin. This supply should have the recommended analog supply decoupling capacitors between the AV_{DD} pin of the AD7851 and AGND and the recommended digital supply decoupling capacitor between the DV_{DD} pin of the AD7851 and DGND.

Evaluating the AD7851 Performance

The recommended layout for the AD7851 is outlined in the evaluation board for the AD7851. The evaluation board package includes a fully assembled and tested evaluation board, documentation, and software for controlling the board from the PC via the EVAL-CONTROL BOARD. The EVAL-CONTROL BOARD can be used in conjunction with the AD7851 Evaluation Board, as well as many other Analog Devices evaluation boards ending in the CB designator, to demonstrate/evaluate the ac and dc performance of the AD7851.

The software allows the user to perform ac (Fast Fourier Transform) and dc (histogram of codes) tests on the AD7851. It also gives full access to all the AD7851 on-chip registers allowing for various calibration and power-down options to be programmed.

AD785x Family

All parts are 12 bit, 200 kSPS, 3.0 V to 5.5 V, except the AD7856 which is 14 bit, 285 kSPS, 5 V supply.

AD7853 – Single-Channel Serial

AD7854 – Single-Channel Parallel

AD7856 – Eight-Channel Serial

AD7858 – Eight-Channel Serial

AD7859 – Eight-Channel Parallel

OUTLINE DIMENSIONS

24-Lead Plastic Dual In-Line Package [PDIP]
(N-24)

Dimensions shown in inches and (millimeters)

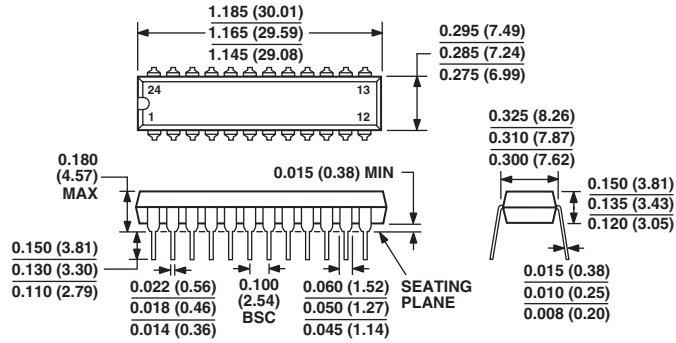

COMPLIANT TO JEDEC STANDARDS MO-095AG

CONTROLLING DIMENSIONS ARE IN INCHES; MILLIMETER DIMENSIONS (IN PARENTHESES) ARE ROUNDED-OFF INCH EQUIVALENTS FOR REFERENCE ONLY AND ARE NOT APPROPRIATE FOR USE IN DESIGN

24-Lead Standard Small Outline Package [SOIC]
Wide Body
(R-24)

Dimensions shown in millimeters and (inches)

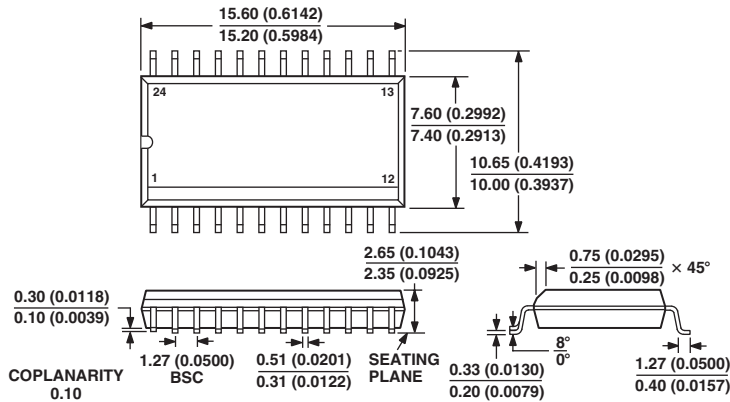

COMPLIANT TO JEDEC STANDARDS MS-013AD

CONTROLLING DIMENSIONS ARE IN MILLIMETERS; INCH DIMENSIONS (IN PARENTHESES) ARE ROUNDED-OFF MILLIMETER EQUIVALENTS FOR REFERENCE ONLY AND ARE NOT APPROPRIATE FOR USE IN DESIGN

24-Lead Shrink Small Outline Package [SSOP]
(RS-24)

Dimensions shown in millimeters

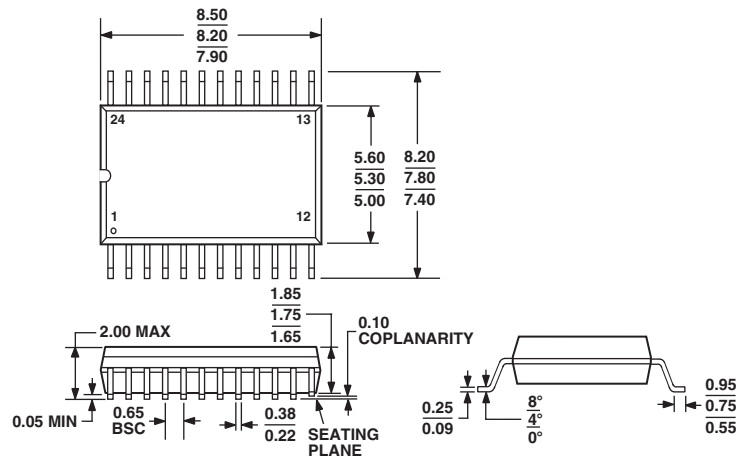

COMPLIANT TO JEDEC STANDARDS MO-150AG

Revision History

Location	Page
3/04—Data Sheet changed from REV. A to REV. B.	
Moved Page Index from Page 33 to Page 2	2
Updated ORDERING GUIDE	7
Updated TERMINOLOGY section	8
Updated PIN FUNCTION DESCRIPTIONS	9
Updated Table II	10
Updated CONTROL REGISTER section	11
Updated Status Register Bit Function Description	12
Updated CIRCUIT INFORMATION section	15
Updated Figure 10	15
Updated TYPICAL CONNECTION DIAGRAM section	15
Updated Figure 12	16
Updated Figure 18 and Figure 19	18
Updated Figure 23	19
Updated Automatic Calibration on Power-On section	21
Updated Mode 4 and 5 section	27
Updated AD7851 as a Read-Only ADC section	28
Updated Figure 40	28
Updated Figure 41	29
Updated Figures 42 and 43	30
Updated Figure 45	31



Компания «ЭлектроПласт» предлагает заключение долгосрочных отношений при поставках импортных электронных компонентов на взаимовыгодных условиях!

Наши преимущества:

- Оперативные поставки широкого спектра электронных компонентов отечественного и импортного производства напрямую от производителей и с крупнейших мировых складов;
- Поставка более 17-ти миллионов наименований электронных компонентов;
- Поставка сложных, дефицитных, либо снятых с производства позиций;
- Оперативные сроки поставки под заказ (от 5 рабочих дней);
- Экспресс доставка в любую точку России;
- Техническая поддержка проекта, помощь в подборе аналогов, поставка прототипов;
- Система менеджмента качества сертифицирована по Международному стандарту ISO 9001;
- Лицензия ФСБ на осуществление работ с использованием сведений, составляющих государственную тайну;
- Поставка специализированных компонентов (Xilinx, Altera, Analog Devices, Intersil, Interpoint, Microsemi, Aeroflex, Peregrine, Syfer, Eurofarad, Texas Instrument, Miteq, Cobham, E2V, MA-COM, Hittite, Mini-Circuits, General Dynamics и др.);

Помимо этого, одним из направлений компании «ЭлектроПласт» является направление «Источники питания». Мы предлагаем Вам помощь Конструкторского отдела:

- Подбор оптимального решения, техническое обоснование при выборе компонента;
- Подбор аналогов;
- Консультации по применению компонента;
- Поставка образцов и прототипов;
- Техническая поддержка проекта;
- Защита от снятия компонента с производства.



Как с нами связаться

Телефон: 8 (812) 309 58 32 (многоканальный)

Факс: 8 (812) 320-02-42

Электронная почта: org@eplast1.ru

Адрес: 198099, г. Санкт-Петербург, ул. Калинина, дом 2, корпус 4, литера А.