

LOW NOISE 150mA LDO REGULATOR

NO. EA-126-0607

OUTLINE

The R1116x Series are CMOS-based voltage regulator ICs with high output voltage accuracy, low supply current, low on Resistance, and high ripple rejection. Each of these ICs consists of a voltage reference unit, an error amplifier, resistor-net for voltage setting, a short current limit circuit, a chip enable circuit, and so on.

These ICs perform with low dropout voltage and the chip-enable function. The supply current at no load of this IC is only 10 μ A, and the line transient response and the load transient response of the R1116x Series are excellent, thus these ICs are very suitable for the power supply for hand-held communication equipment.

The supply current at no load of R1116x Series is remarkably reduced compared with R1114x Series. The mode change signal to reduce the supply current is not necessary. The output voltage accuracy is also improved. ($\pm 1.5\%$)

The output voltage of these ICs is fixed with high accuracy. Since the packages for these ICs are SOT-23-5 and SON1612-6 therefore high density mounting of the ICs on boards is possible.

R1126N Series that a pin configuration differs from R1116N Series are available.

FEATURES

- Low Supply Current Typ. 10 μ A
- Standby Current Typ. 0.1 μ A
- Input Voltage Range 1.8V to 6.0V
- Output Voltage Range 1.5V to 4.0V
- Low Dropout Voltage Typ. 0.29V ($I_{OUT}=150\text{mA}, V_{OUT}=2.8\text{V}$)
- High Ripple Rejection Typ. 70dB ($f=1\text{kHz}, V_{OUT}=3.0\text{V}$)
Typ. 53dB ($f=10\text{kHz}$)
- High Output Voltage Accuracy $\pm 1.5\%$ ($1.5\text{V} \leq V_{OUT} \leq 3.0\text{V}$), $\pm 2.0\%$ ($V_{OUT}>3.0\text{V}$)
- Low Temperature-Drift Coefficient of Output Voltage Typ. $\pm 100\text{ppm}/^\circ\text{C}$
- Excellent Line Regulation Typ. 0.02%/V
- Small Packages SOT-23-5, SON1612-6
- Built-in Fold Back Protection Circuit Typ. 40mA (Current at short mode)
- Ceramic capacitors are recommended to be used with this IC ... $C_{IN}=C_{OUT}=1.0\mu\text{F}$ (Ceramic)

APPLICATIONS

- Power source for portable communication equipment.
- Power source for portable music player.
- Power source for electrical appliances such as cameras, VCRs and camcorders.
- Power source for battery-powered equipment.

BLOCK DIAGRAMS

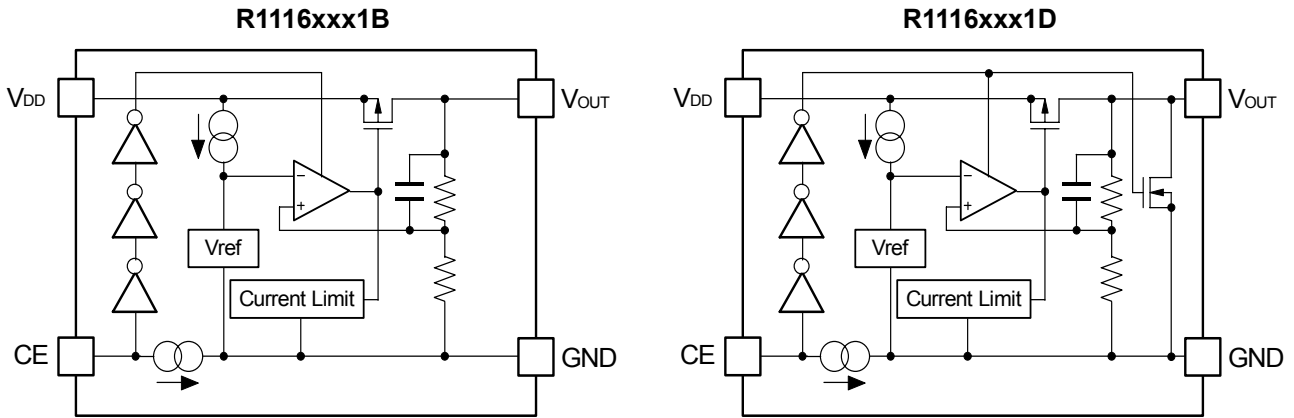

SELECTION GUIDE

The output voltage, version, and the taping type for the ICs can be selected at the user's request. The selection can be made with designating the part number as shown below;

R1116xxx1x-xx-X ← Part Number
 ↑ ↑ ↑ ↑ ↑
 a b c d e

Code	Contents
a	Designation of Package Type: N: SOT-23-5 D: SON1612-6
b	Setting Output Voltage (V_{OUT}): Stepwise setting with a step of 0.1V in the range of 1.5V to 4.0V is possible. Exceptions: 2.85V=R1116x281x5, 1.85V=R1116x181x5
c	Designation of Active Type: B: active high type D: active high, with auto discharge
d	Designation of Taping Type: Ex. TR (refer to Taping Specifications; TR type is the standard direction.)
e	Designation of composition of pin plating: -F: Lead free plating (SOT-23-5, SON1612-6)

PIN CONFIGURATIONS

● SOT-23-5

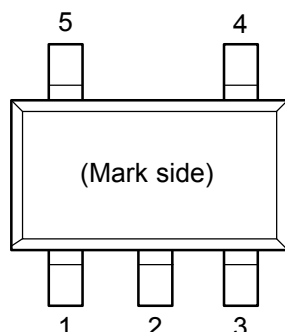

● SON1612-6

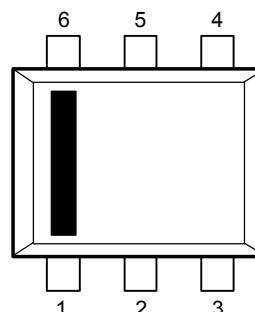

PIN DESCRIPTIONS

● R1116N

Pin No.	Symbol	Description
1	V_{DD}	Input Pin
2	GND	Ground Pin
3	CE	Chip Enable Pin
4	NC	No Connection
5	V_{OUT}	Output pin

● R1116D

Pin No.	Symbol	Description
1	CE	Chip Enable Pin
2	GND	Ground Pin
3	V_{DD}	Input Pin
4	V_{OUT}	Output Pin
5	GND	Ground Pin
6	NC	No Connection

ABSOLUTE MAXIMUM RATINGS

Symbol	Item	Rating	Unit
V_{IN}	Input Voltage	6.5	V
V_{CE}	Input Voltage (CE Pin)	6.5	V
V_{OUT}	Output Voltage	$-0.3 \sim V_{IN} + 0.3$	V
I_{OUT}	Output Current	160	mA
P_D	Power Dissipation (SOT-23-5)*1	420	mW
	Power Dissipation (SON1612-6)*1	500	
T_{opt}	Operating Temperature Range	$-40 \sim 85$	$^{\circ}\text{C}$
T_{stg}	Storage Temperature Range	$-55 \sim 125$	$^{\circ}\text{C}$

*1 For Power Dissipation, please refer to PACKAGE INFORMATION to be described.

ELECTRICAL CHARACTERISTICS

• R1116xxx1B/D

T_{opt}=25°C

Symbol	Item	Conditions	Min.	Typ.	Max.	Unit
V _{OUT}	Output Voltage	V _{IN} = Set V _{OUT} +1V 1mA ≤ I _{OUT} ≤ 30mA	V _{OUT} ≤ 3.0V ×0.985		×1.015	V
			V _{OUT} > 3.0V ×0.980		×1.020	
I _{OUT}	Output Current	V _{IN} -V _{OUT} =1.0V	150			mA
ΔV _{OUT} / ΔI _{OUT}	Load Regulation	V _{IN} =Set V _{OUT} +1V 1mA ≤ I _{OUT} ≤ 150mA 1.5V ≤ V _{OUT} < 2.0V 2.0V ≤ V _{OUT} < 3.0V 3.0V ≤ V _{OUT}		28 33 35	55 66 80	mV
V _{DIF}	Dropout Voltage	Refer to the ELECTRICAL CHARACTERISTICS by OUTPUT VOLTAGE				
I _{SS}	Supply Current	V _{IN} =Set V _{OUT} +1V, I _{OUT} =0mA		10	18	μA
I _{standby}	Supply Current (Standby)	V _{IN} =Set V _{OUT} +1V, V _{CE} =V _{DD}		0.1	1.0	μA
ΔV _{OUT} / ΔV _{IN}	Line Regulation	I _{OUT} =30mA Set V _{OUT} +0.5V ≤ V _{IN} ≤ 6.0V		0.02	0.10	%/V
RR	Ripple Rejection	f=1kHz f=10kHz Ripple 0.2Vp-p V _{IN} -V _{OUT} =1.0V, I _{OUT} =30mA		70 53		dB
V _{IN}	Input Voltage		1.8		6.0	V
ΔV _{OUT} / ΔT _{opt}	Output Voltage Temperature Coefficient	I _{OUT} =30mA -40°C ≤ T _{opt} ≤ 85°C		±100		ppm /°C
I _{lim}	Short Current Limit	V _{OUT} =0V		40		mA
I _{PD}	CE Pull-down Current			0.5		μA
V _{CEH}	CE Input Voltage "H"		1.0		6.0	V
V _{CEL}	CE Input Voltage "L"		0.0		0.3	V
en	Output Noise	BW=10Hz to 100kHz		30		μVrms
R _{LOW}	On Resistance of Nch Tr. for auto-discharge (Only for D version)	V _{CE} =0V		70		Ω

• ELECTRICAL CHARACTERISTICS by OUTPUT VOLTAGE

T_{opt} = 25°C

Output Voltage V _{OUT} (V)	Dropout Voltage V _{DIF} (V)		
	Condition	Typ.	Max.
V _{OUT} = 1.5V	I _{OUT} =150mA	0.54	0.86
1.5V < V _{OUT} ≤ 1.6V		0.50	0.75
1.6V < V _{OUT} ≤ 1.7V		0.46	0.70
1.7V < V _{OUT} ≤ 2.0V		0.44	0.65
2.0V < V _{OUT} ≤ 2.7V		0.37	0.56
2.7V < V _{OUT} ≤ 4.0V		0.29	0.46

TYPICAL APPLICATIONS

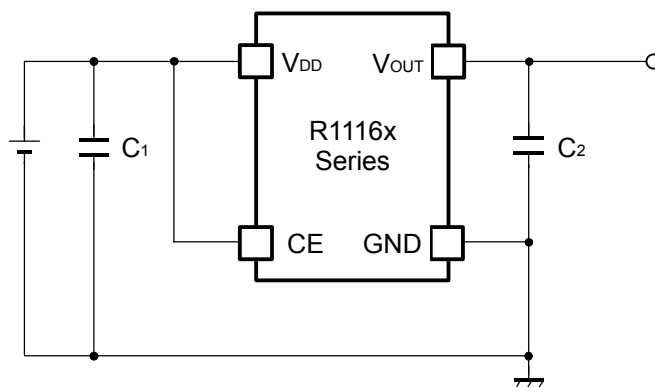

(External Components)

C₂ Ceramic 1.0μF Ex. Murata GRM155B30J105KE18B
Kyocera CM05X5R105K06AB

C₁ Ceramic 1.0μF

TEST CIRCUITS

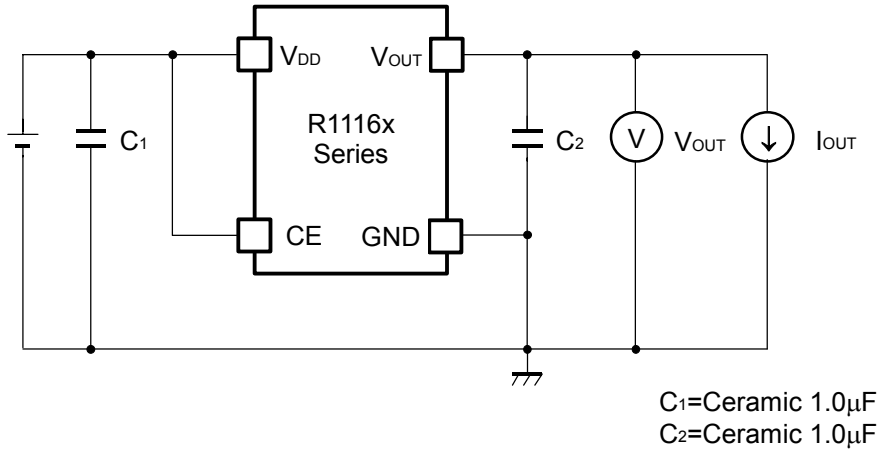

Fig.1 Standard test Circuit

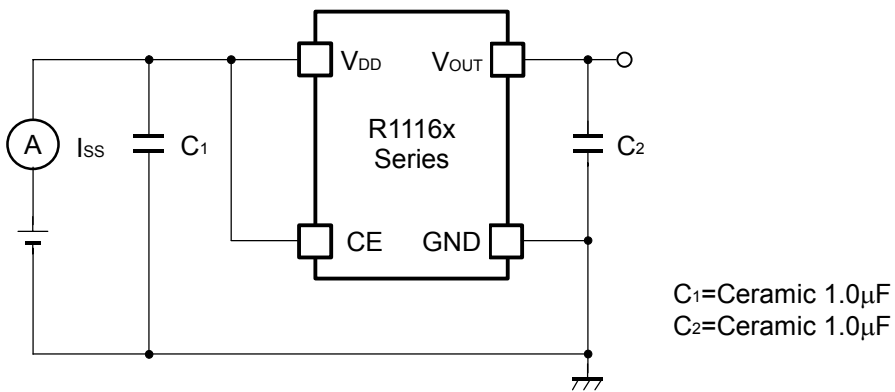

Fig.2 Supply Current Test Circuit

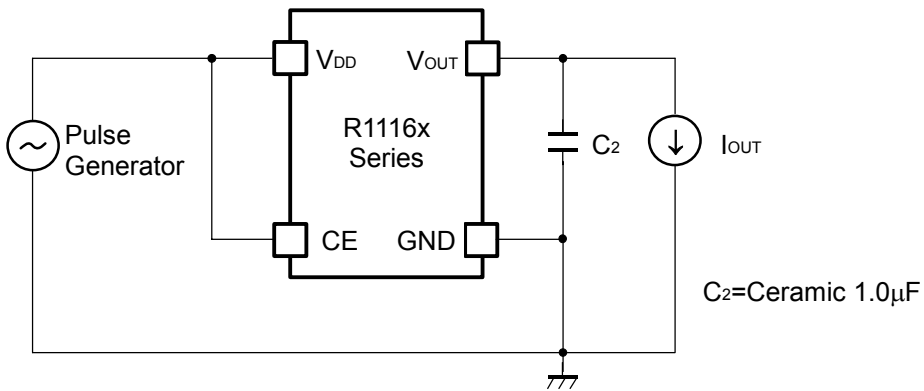
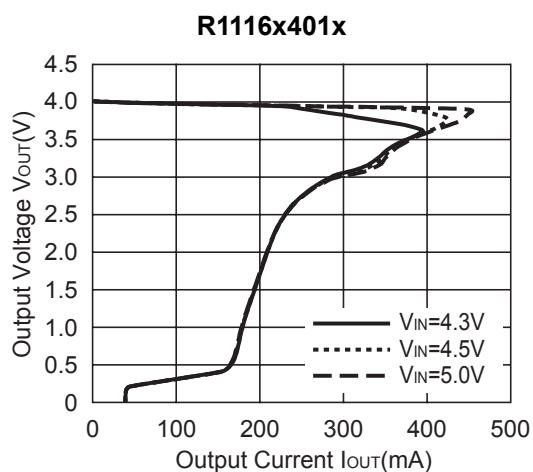
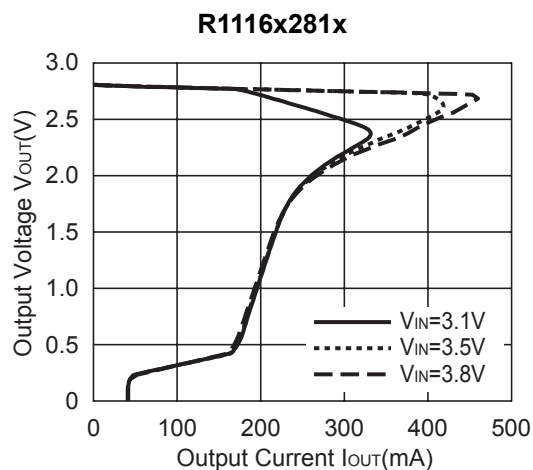
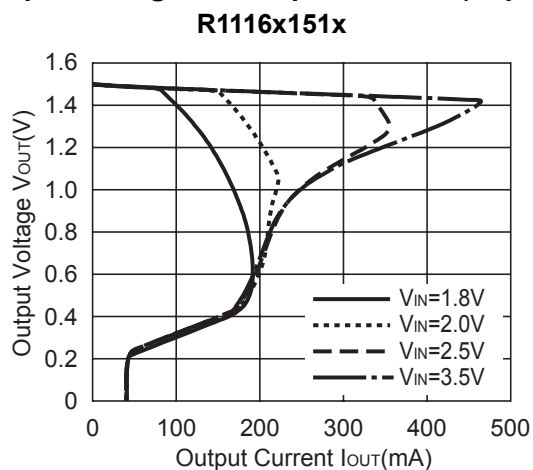

Fig.3 Ripple Rejection, Line Transient Response Test Circuit

TYPICAL CHARACTERISTICS

1) Output Voltage vs. Output Current (T_{opt}=25°C)



2) Output Voltage vs. Input Voltage (T_{opt}=25°C)

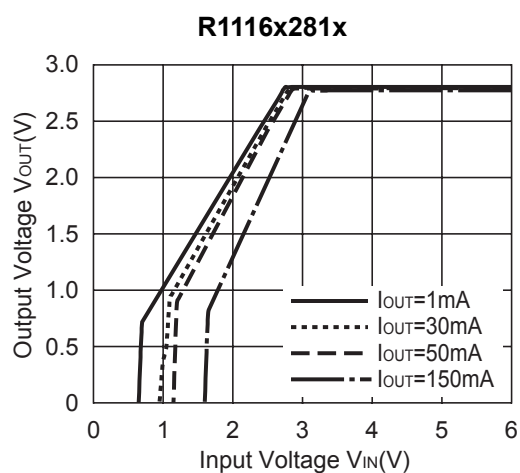
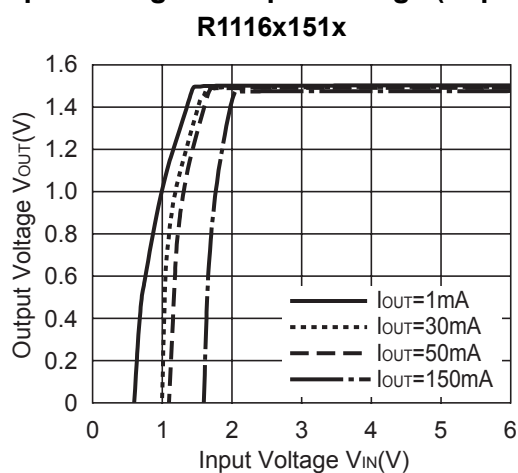

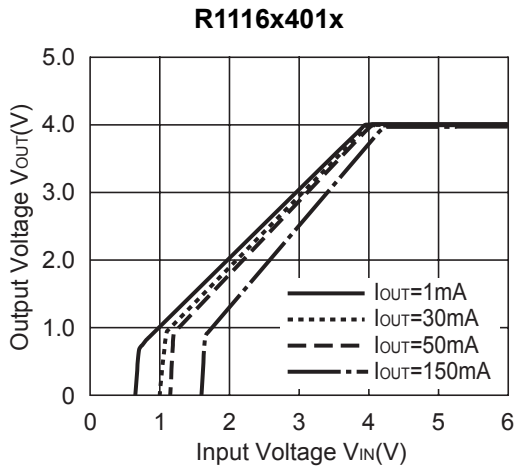

3) Supply Current vs. Input Voltage ($T_{opt}=25^{\circ}C$)

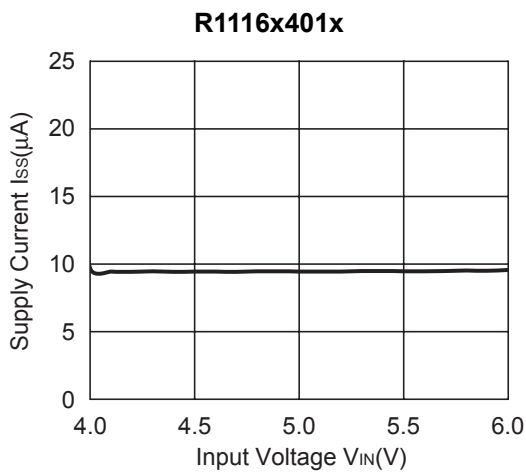
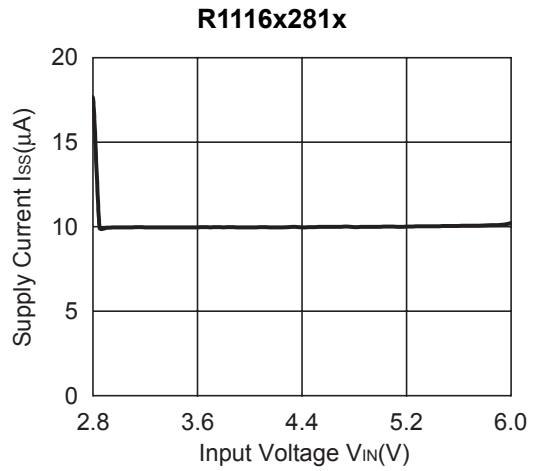
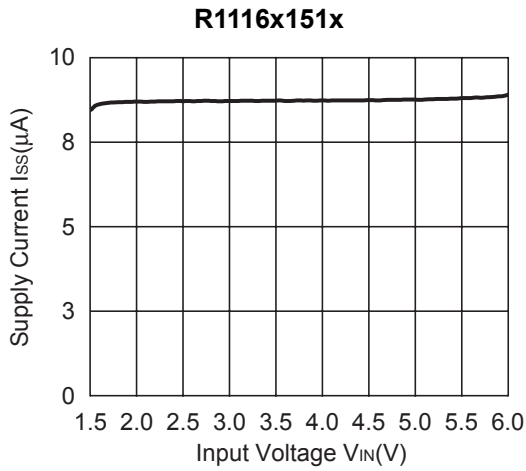

4) Output Voltage vs. Temperature

R1116x151x

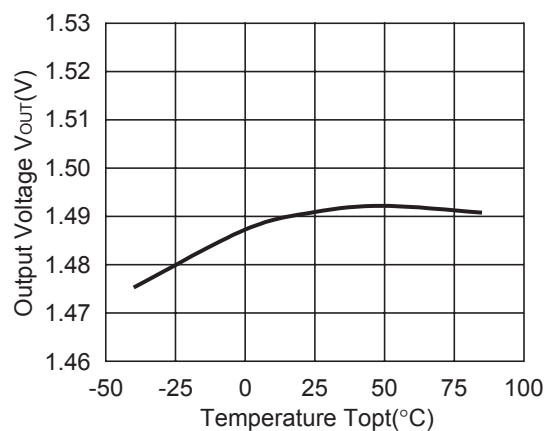

R1116x281x

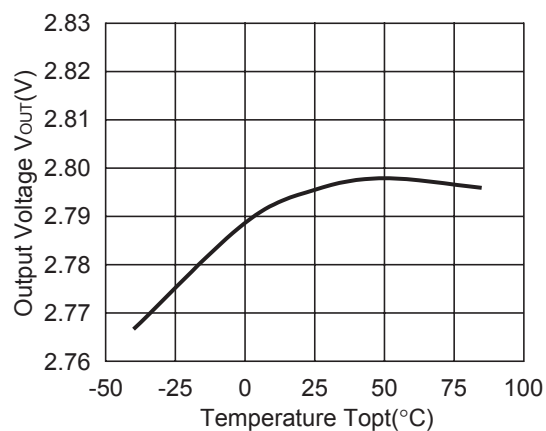

R1116x401x

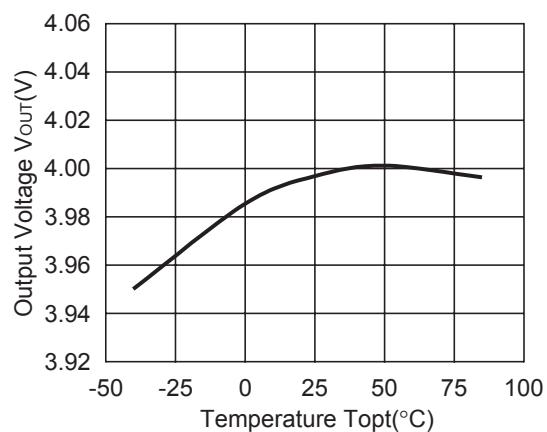

5) Supply Current vs. Temperature

R1116x151x

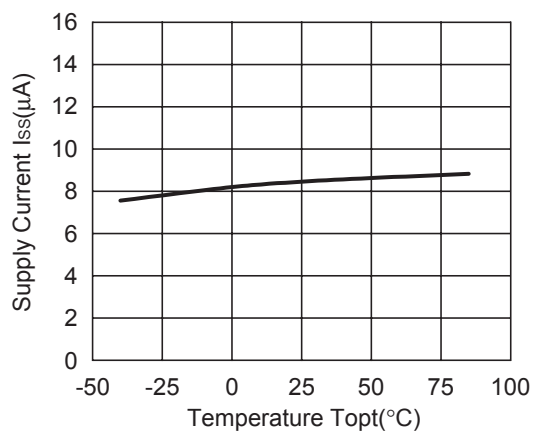

R1116x281x

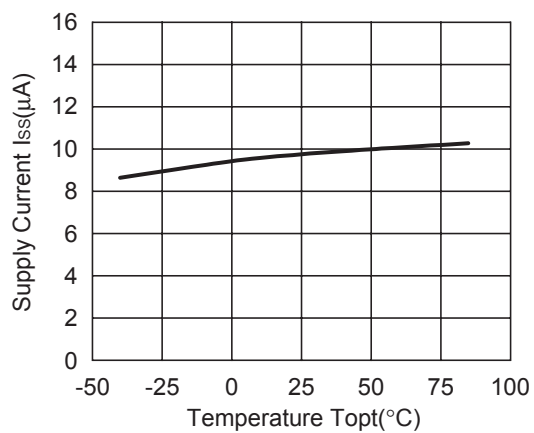

R1116x401x

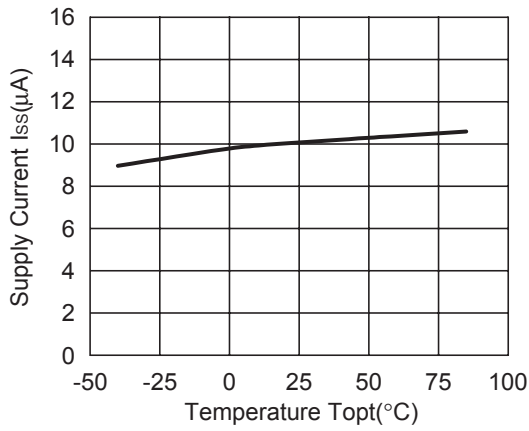

6) Dropout Voltage vs. Temperature

R1116x151x

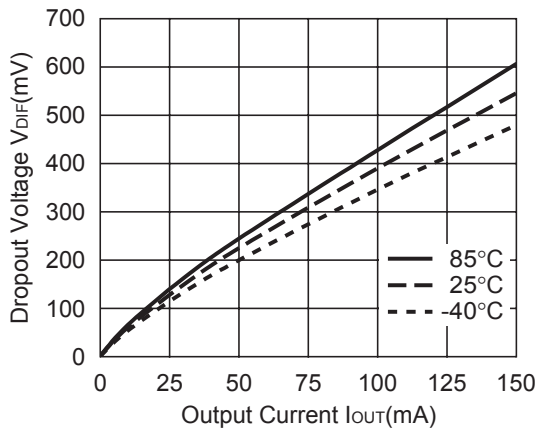

R1116x161x

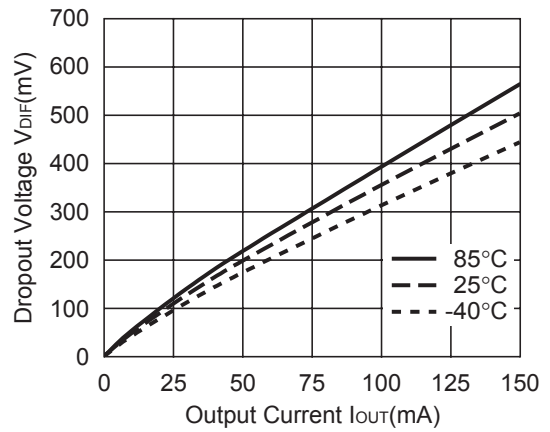

R1116x171x

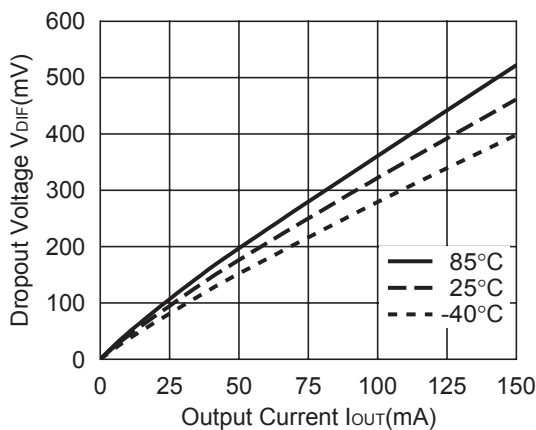

R1116x181x

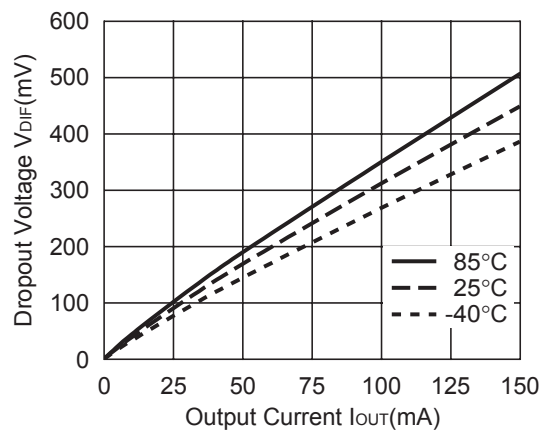

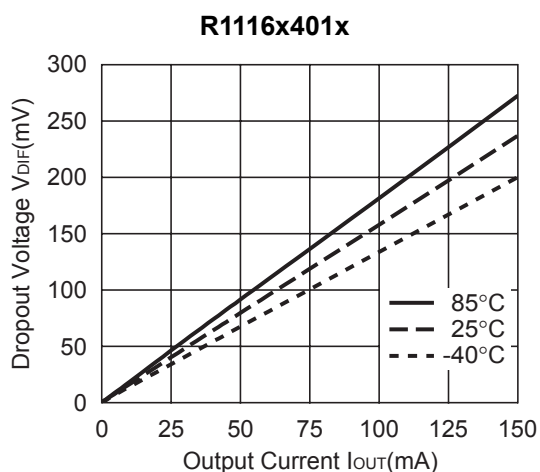
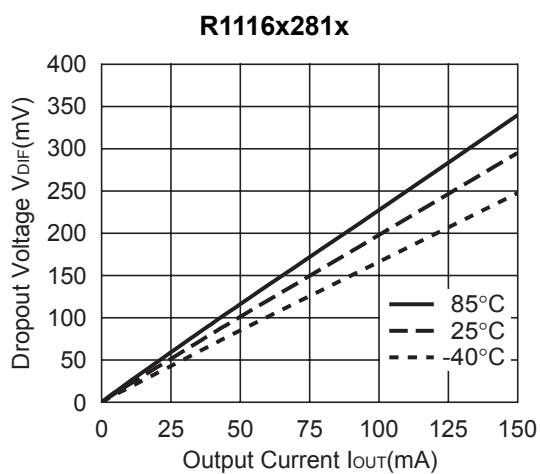
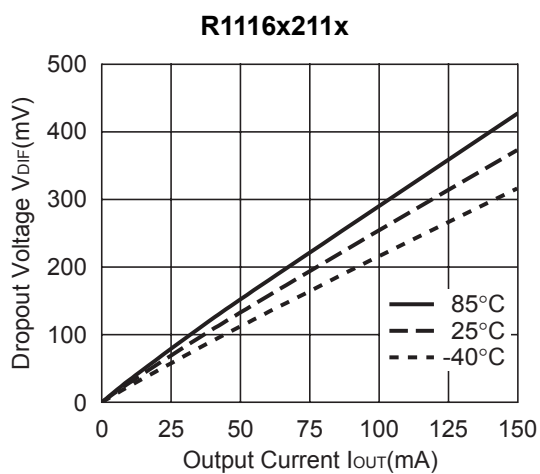

7) Dropout Voltage vs. Set Output Voltage (T_{opt}=25°C)

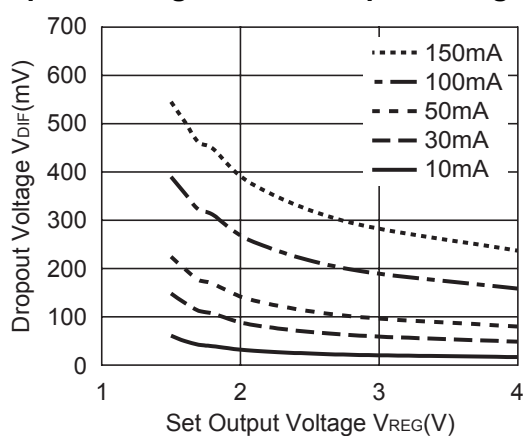

8) Ripple Rejection vs. Input Bias Voltage ($T_{opt}=25^{\circ}C$, $C_{IN} = \text{none}$, $C_{OUT} = 1\mu F$)

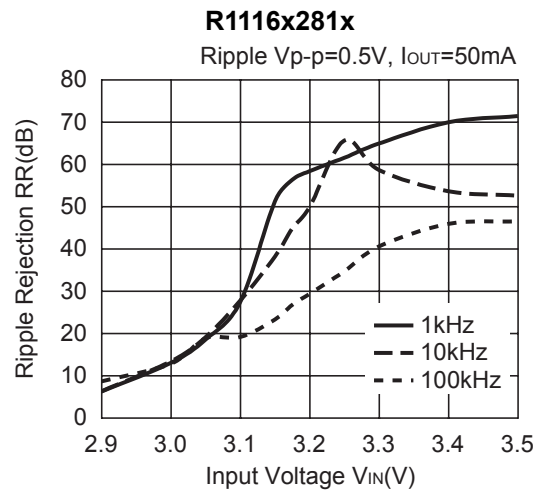
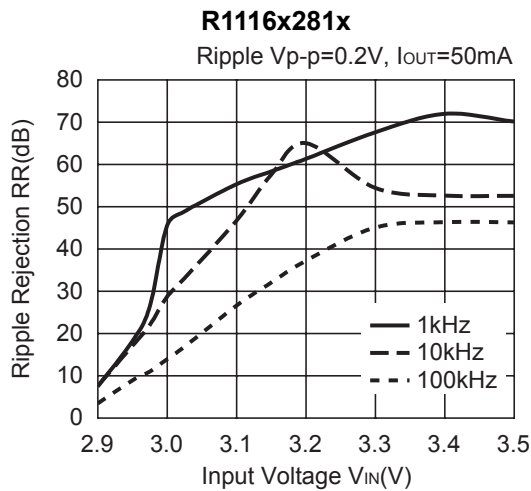
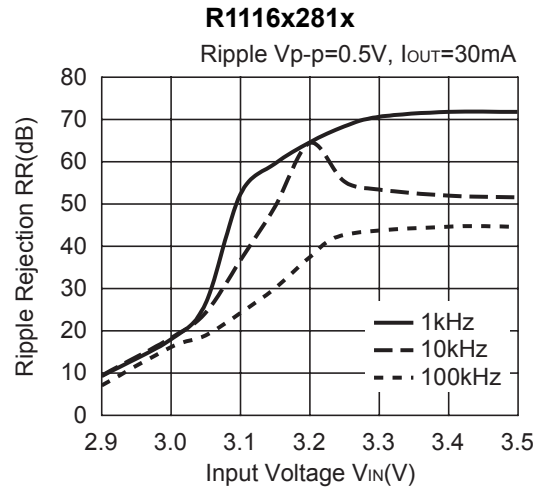
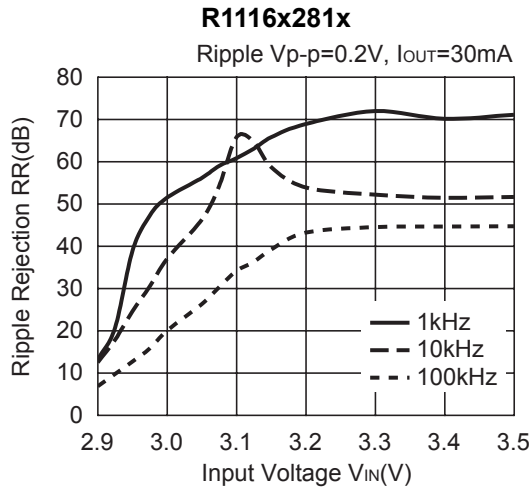
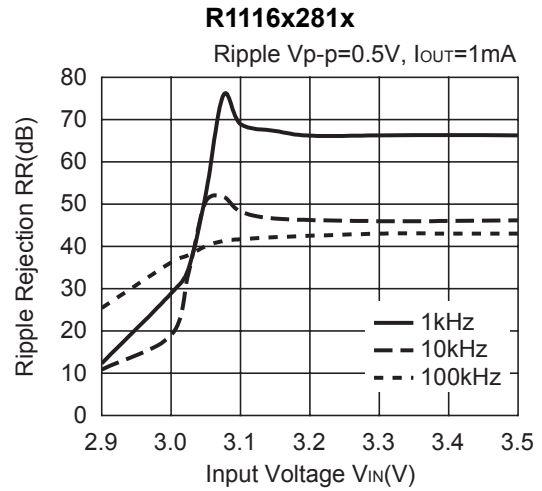
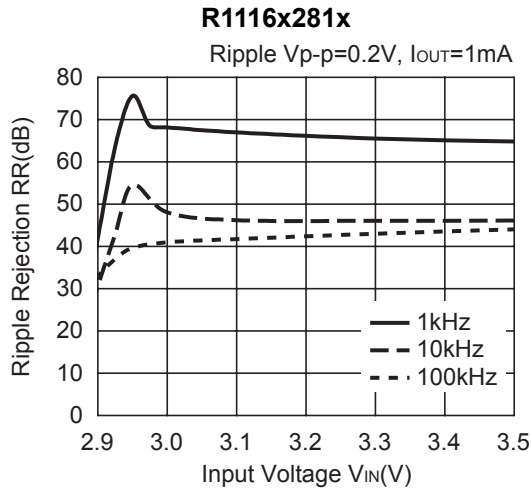

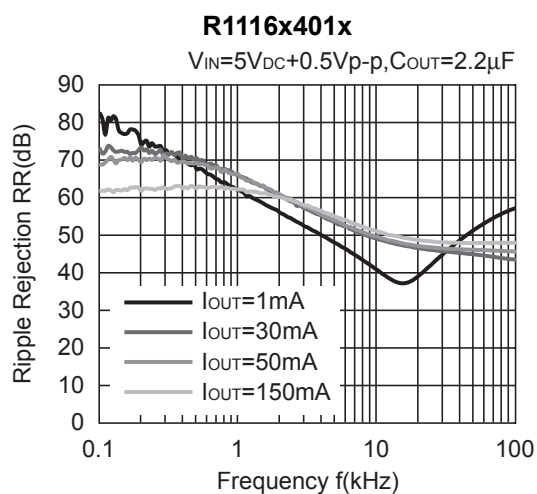
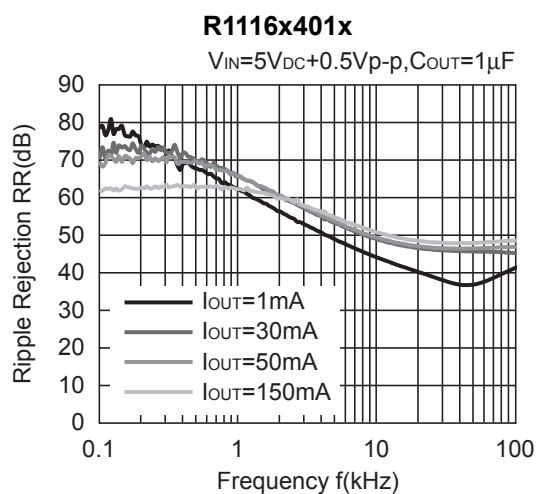
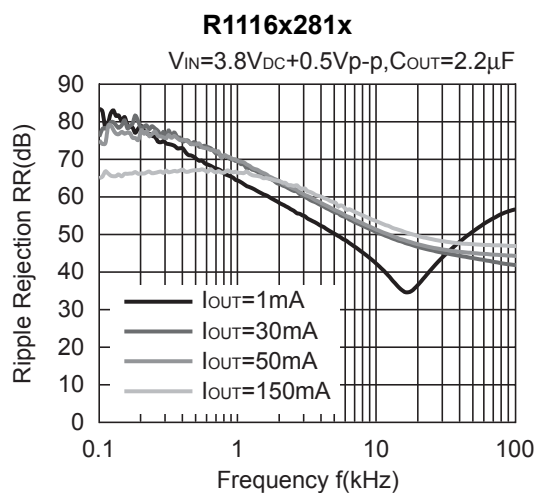
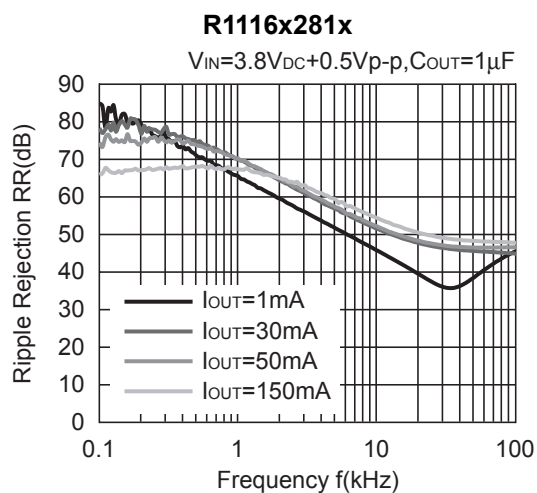
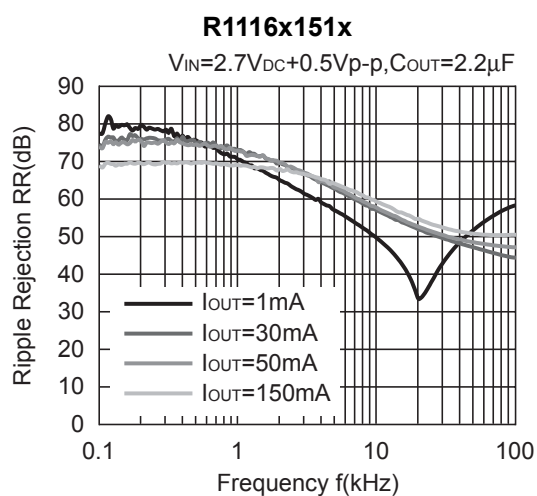
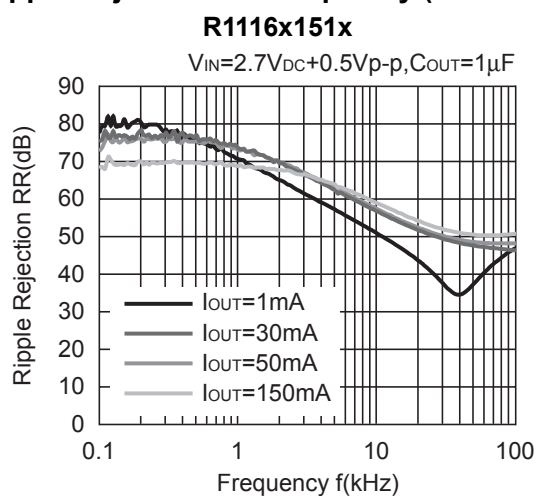
9) Ripple Rejection vs. Frequency ($C_{IN}=\text{none}$)

10) Input Transient Response ($I_{OUT}=30mA$, $C_{IN}=none$, $t_r=t_f=5\mu s$, $C_{OUT}=Ceramic\ 1\mu F$)

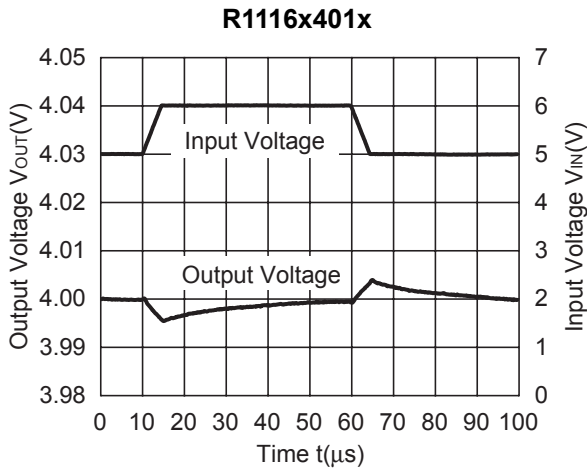
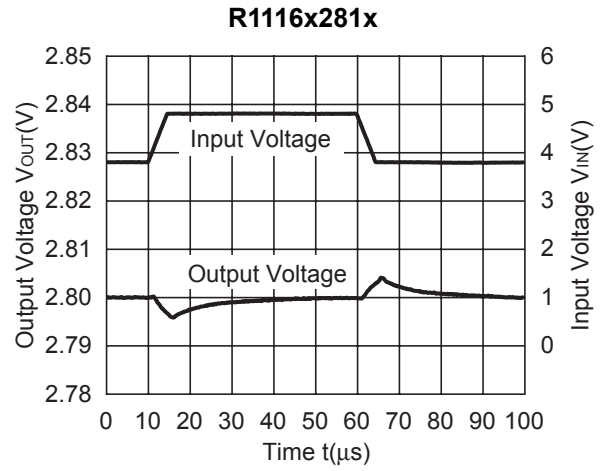
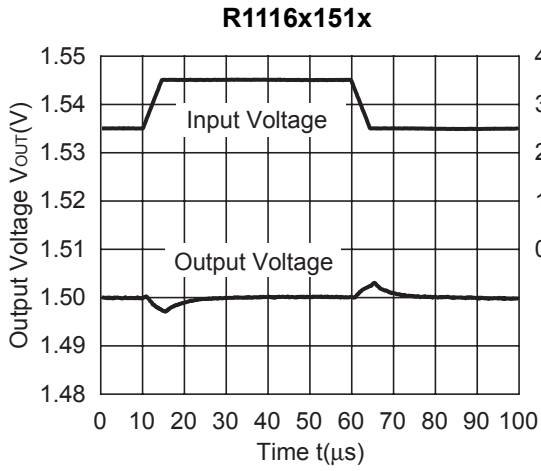

11) Load Transient Response ($t_r=t_f=0.5\mu s$, $C_{IN}=Ceramic\ 1\mu F$)

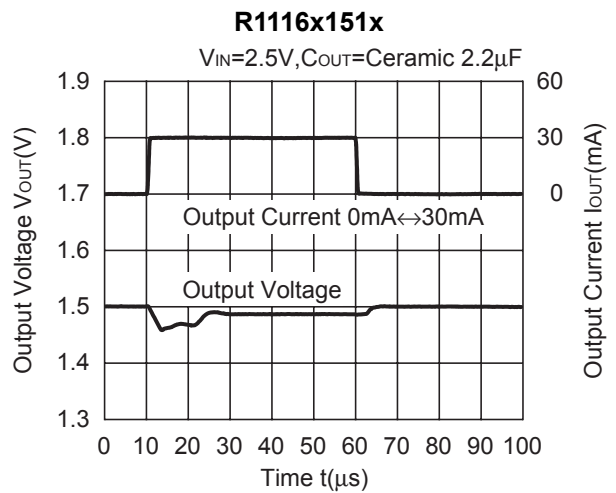
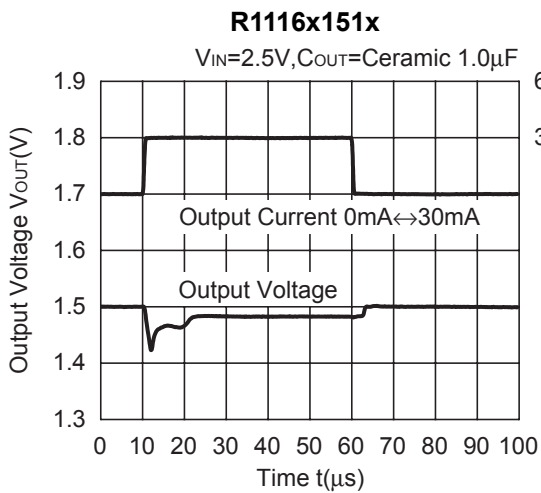

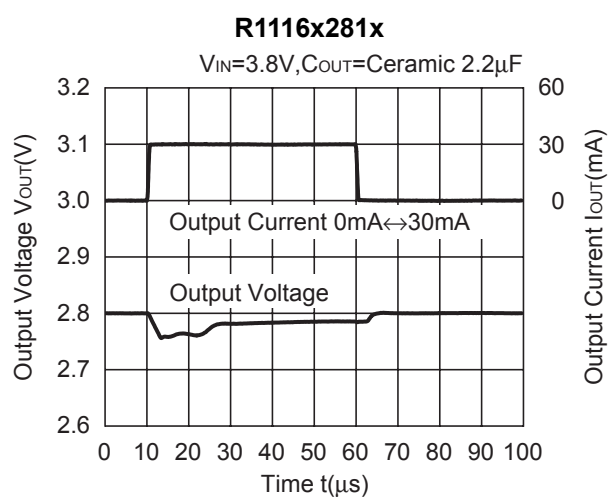
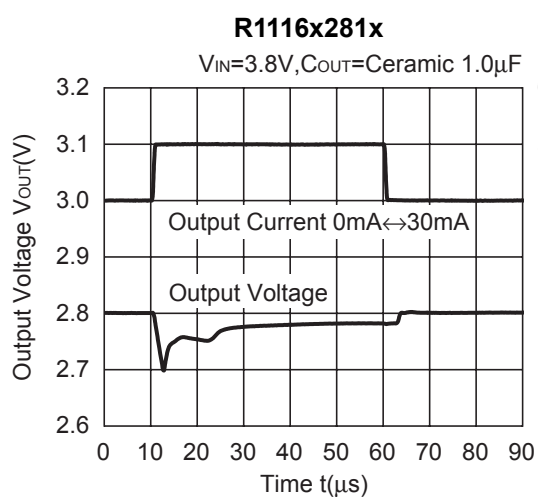
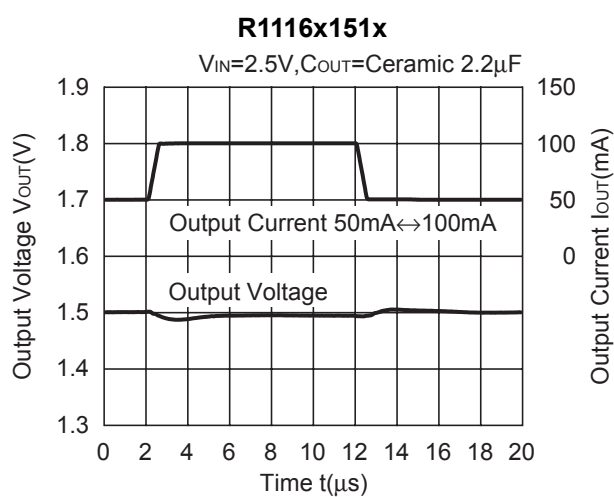
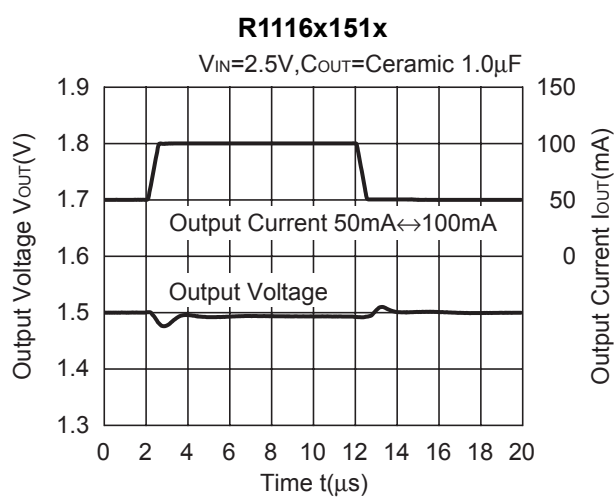
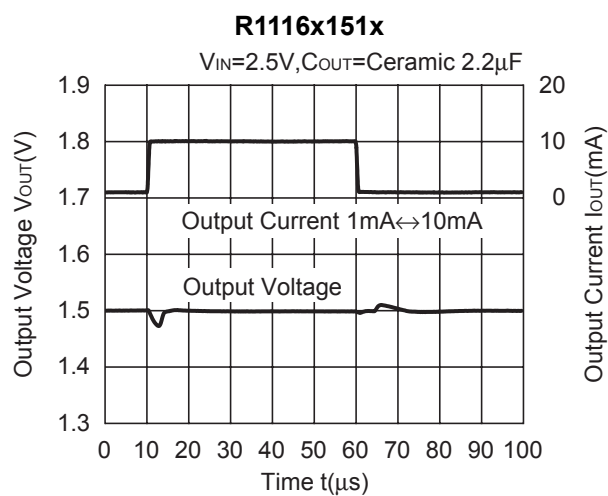
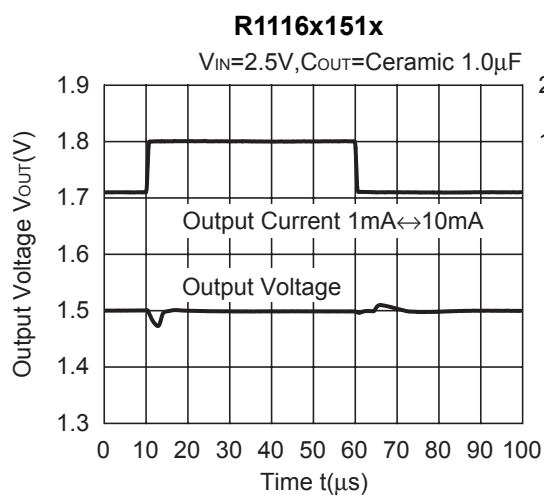

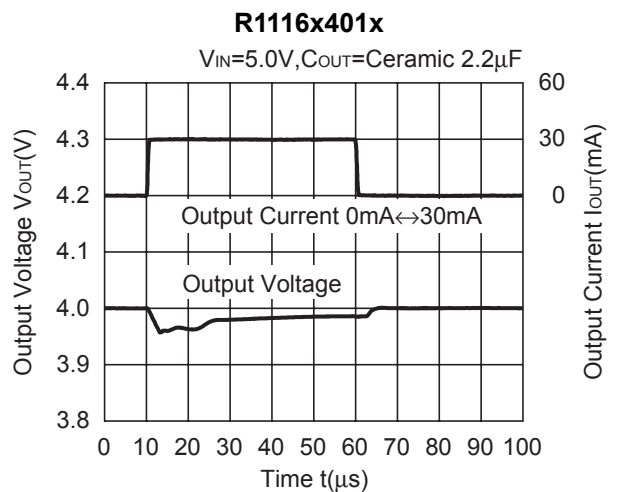
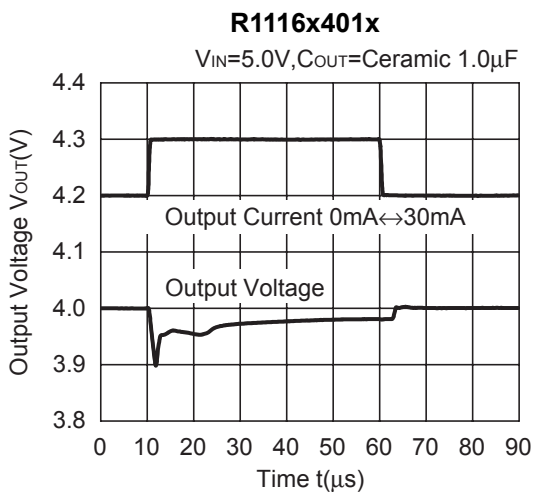
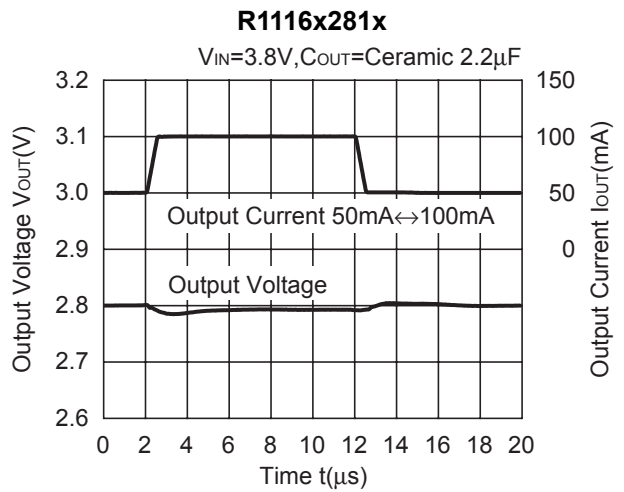
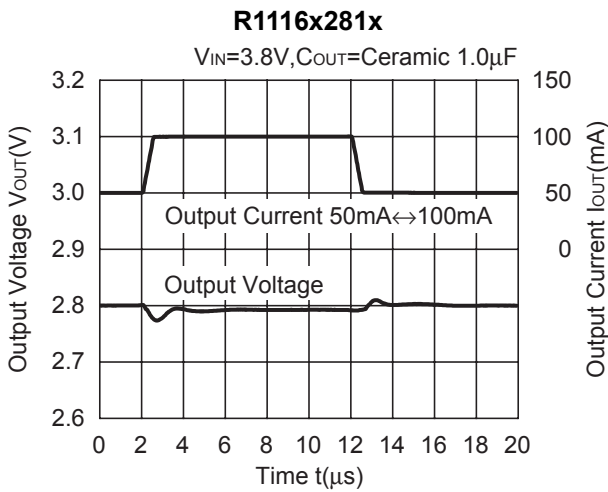
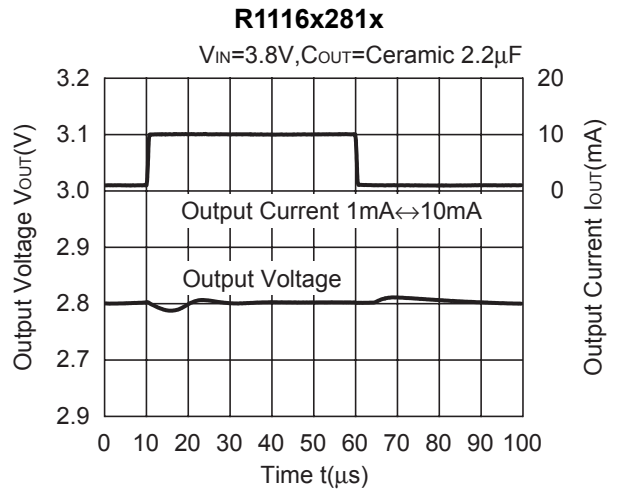
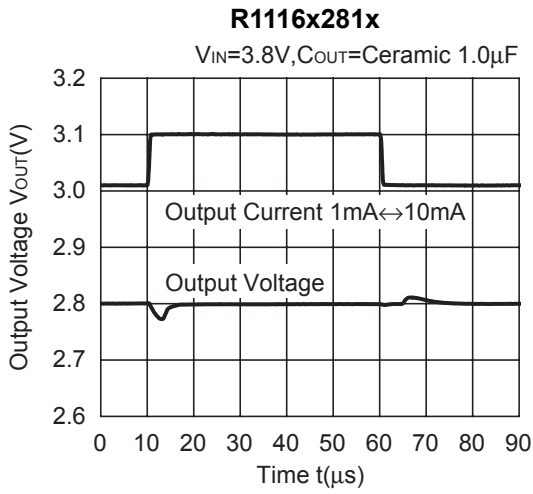

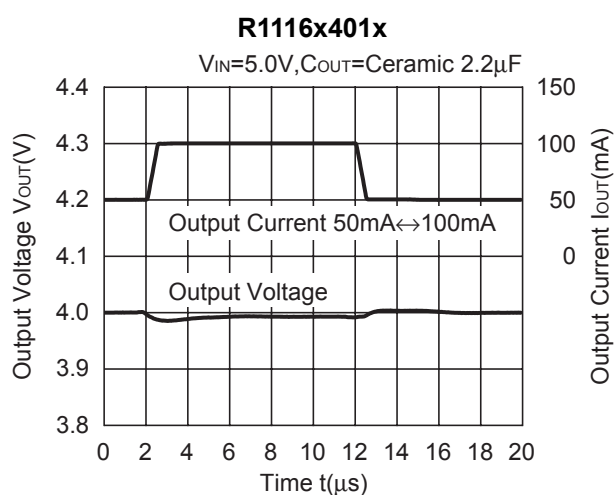
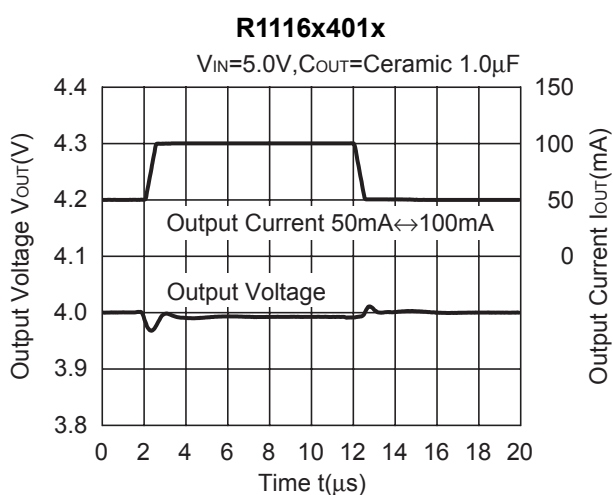
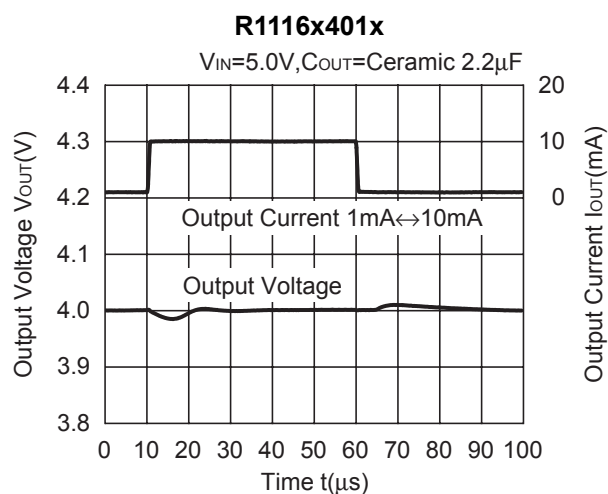
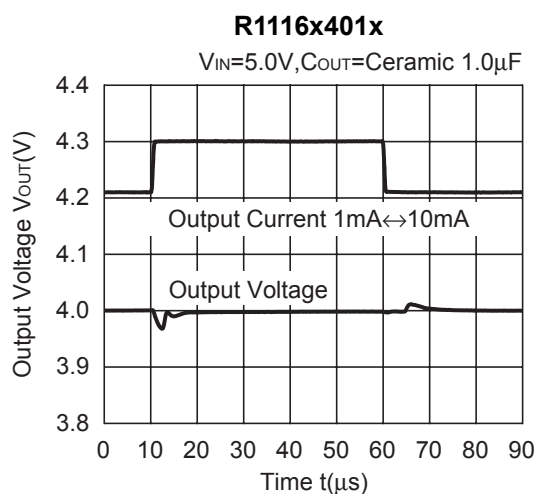

12) Turn-on/off speed with CE pin (D version) ($C_{IN}=\text{Ceramic } 1.0\mu F, C_{OUT}=\text{Ceramic } 1.0\mu F$)

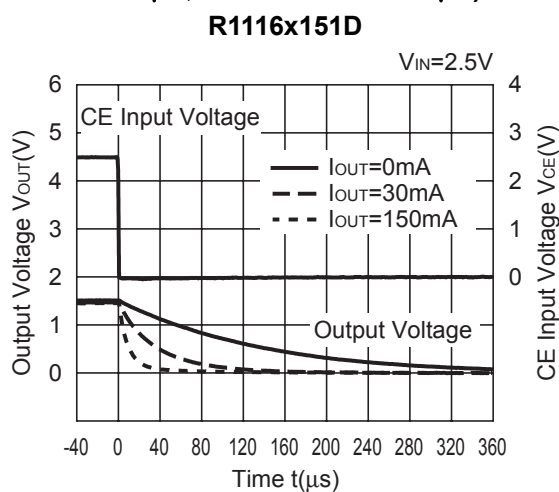
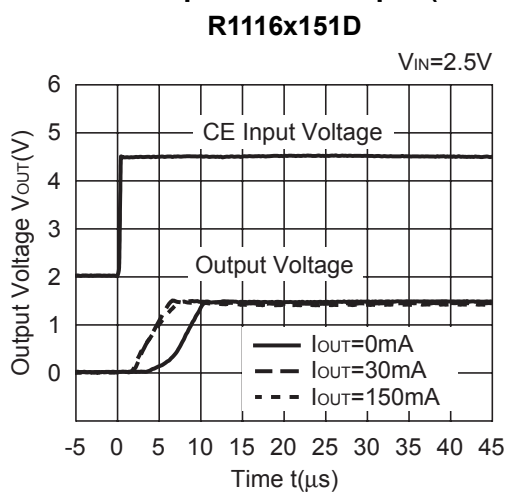

R1116x281D

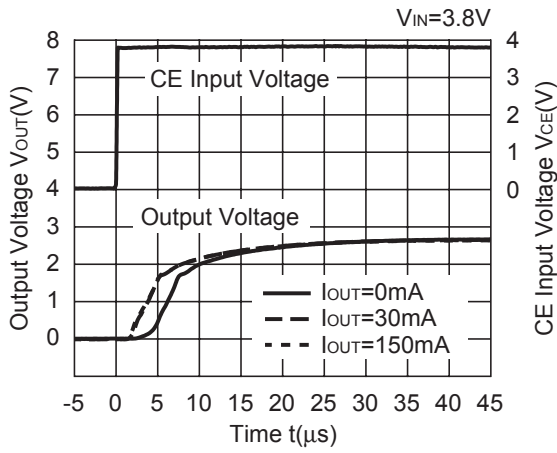

R1116x281D

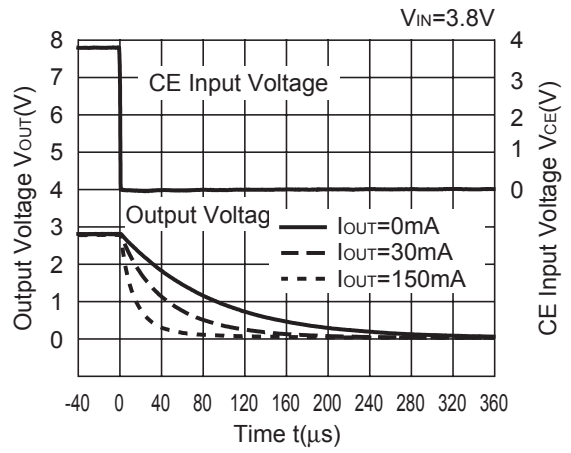

R1116x401D

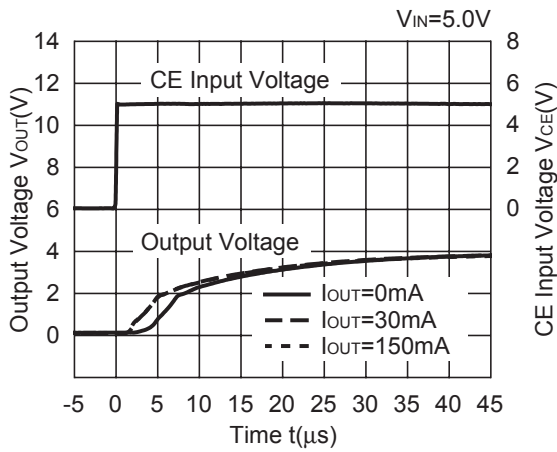

R1116x401D

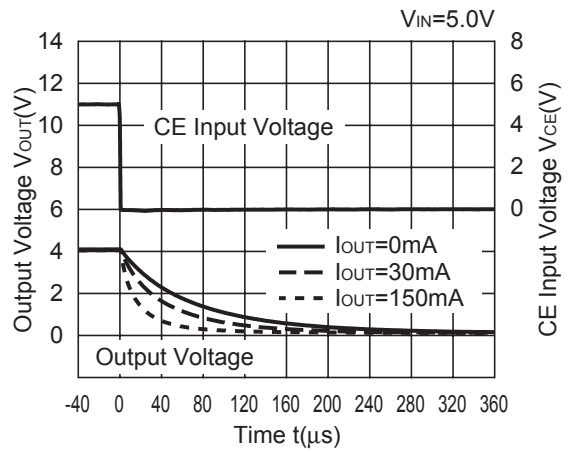

TECHNICAL NOTES

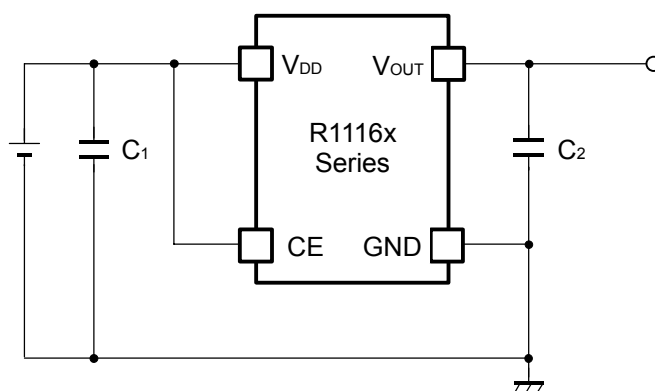

(External Components)

C₂ Ceramic 1.0 μ F Ex. Murata GRM155B30J105KE18B
Kyocera CM05X5R105K06AB

C₁ Ceramic 1.0 μ F

When using these ICs, consider the following points:

1. Mounting on PCB

Make V_{DD} and GND lines sufficient. If their impedance is high, noise pickup or unstable operation may result. Connect a capacitor with a capacitance value as much as 1.0 μ F or more as C₁ between V_{DD} and GND pin, and as close as possible to the pins.

Set external components, especially the output capacitor, as close as possible to the ICs, and make wiring as short as possible.

2. Phase Compensation

In these ICs, phase compensation is made for securing stable operation even if the load current is varied. For this purpose, use a capacitor C₂ with good frequency characteristics and ESR (Equivalent Series Resistance). (Note: If additional ceramic capacitors are connected with parallel to the output pin with an output capacitor for phase compensation, the operation might be unstable. Because of this, test these ICs with as same external components as ones to be used on the PCB.)

If you use a tantalum type capacitor and ESR value of the capacitor is large, output might be unstable. Evaluate your circuit with considering frequency characteristics.

Depending on the capacitor size, manufacturer, and part number, the bias characteristics and temperature characteristics are different. Evaluate the circuit with actual using capacitors.

ESR vs. Output Current

When using these ICs, consider the following points:

The relations between I_{OUT} (Output Current) and ESR of an output capacitor are shown below.

The conditions when the white noise level is under $40\mu\text{V}$ (Avg.) are marked as the hatched area in the graph.

Measurement conditions

$V_{IN}=V_{OUT}+1\text{V}$

C_{OUT} : GRM155B30J105KE18B

Frequency Band: 10Hz to 2MHz

Temperature: -40°C to 25°C

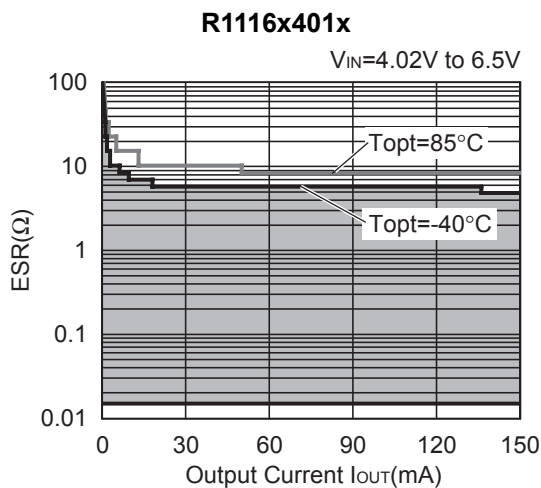
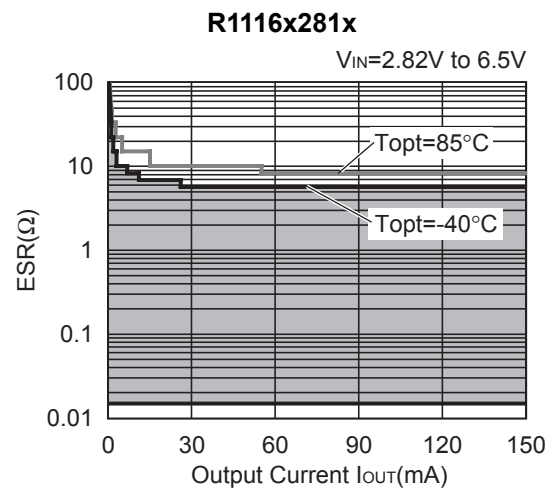
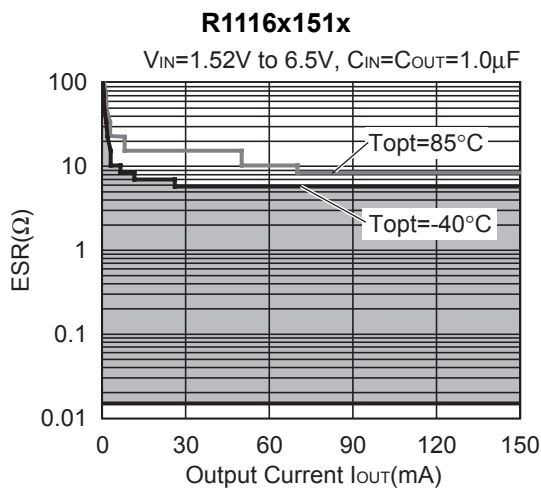

- SOT-23-5 (SC-74A)

Unit: mm

PACKAGE DIMENSIONS

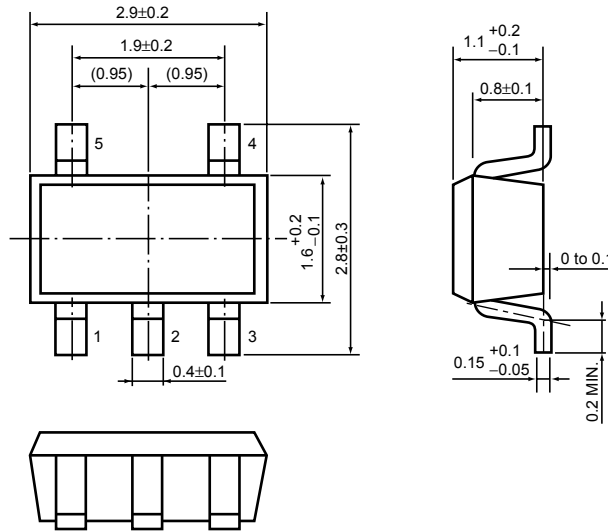

TAPING SPECIFICATION

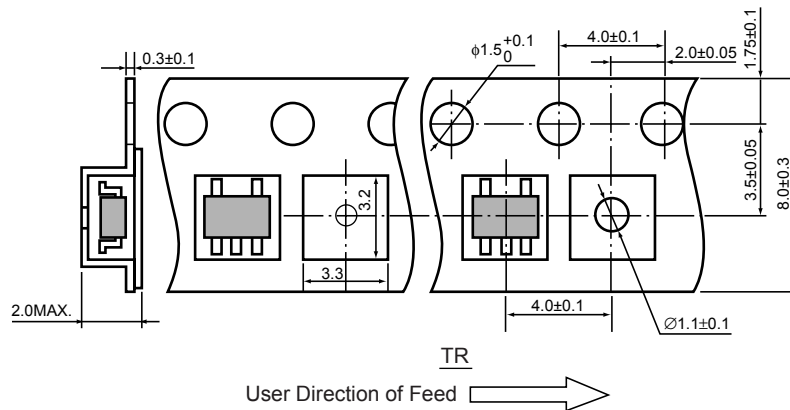

TAPING REEL DIMENSIONS

(1reel=3000pcs)

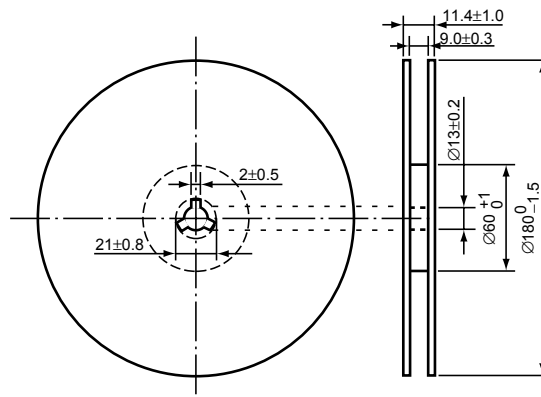

POWER DISSIPATION (SOT-23-5)

This specification is at mounted on board. Power Dissipation (P_D) depends on conditions of mounting on board.

This specification is based on the measurement at the condition below:

(Power Dissipation (SOT-23-5) is substitution of SOT-23-6.)

Measurement Conditions

	Standard Land Pattern
Environment	Mounting on Board (Wind velocity=0m/s)
Board Material	Glass cloth epoxy plactic (Double sided)
Board Dimensions	40mm × 40mm × 1.6mm
Copper Ratio	Top side : Approx. 50% , Back side : Approx. 50%
Through-hole	φ0.5mm × 44pcs

Measurement Result

($T_{opt}=25^{\circ}C, T_{jmax}=125^{\circ}C$)

	Standard Land Pattern	Free Air
Power Dissipation	420mW	250mW
Thermal Resistance	$\theta_{ja}=(125-25^{\circ}C)/0.42W=263^{\circ}C/W$	400 $^{\circ}C/W$

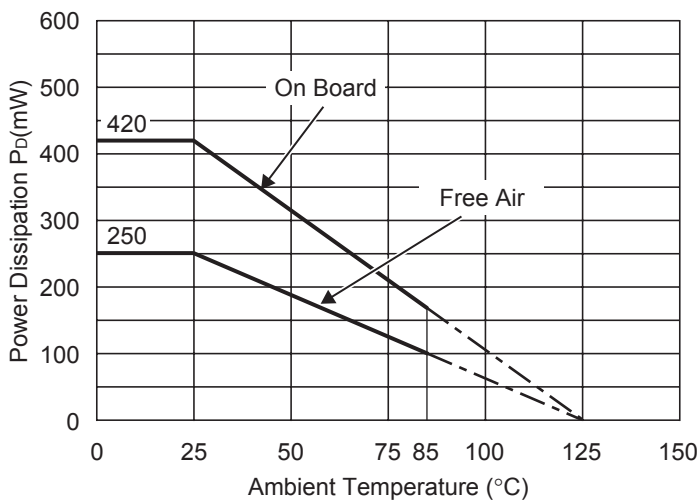

Power Dissipation

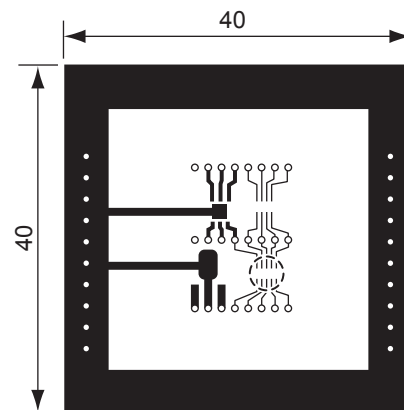

Measurement Board Pattern

○ IC Mount Area Unit : mm

RECOMMENDED LAND PATTERN

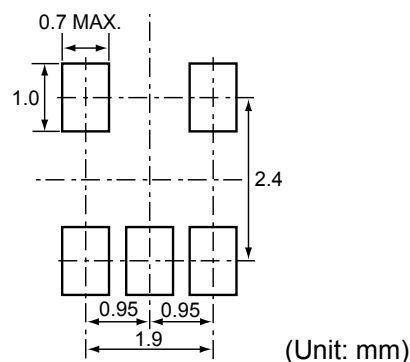

• SON1612-6

Unit: mm

PACKAGE DIMENSIONS

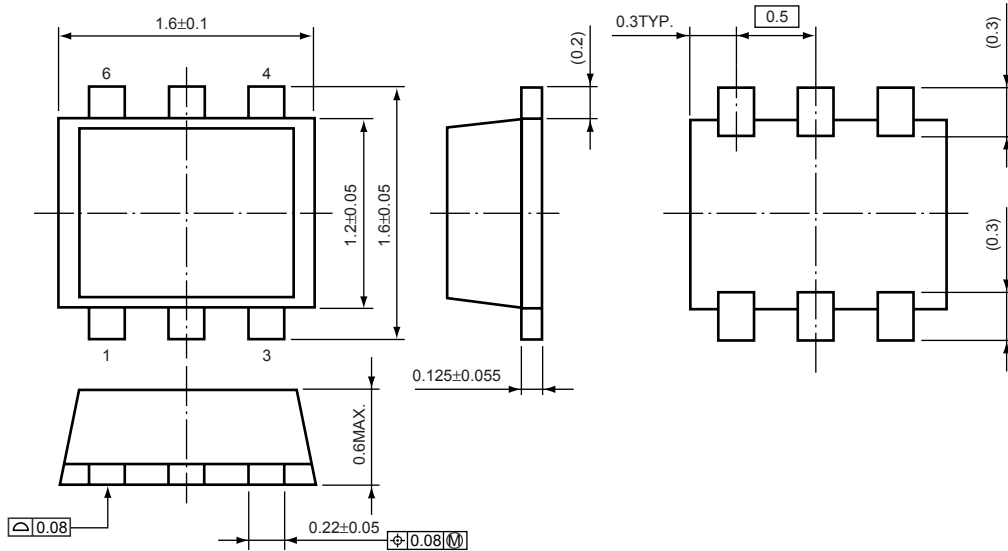

TAPING SPECIFICATION

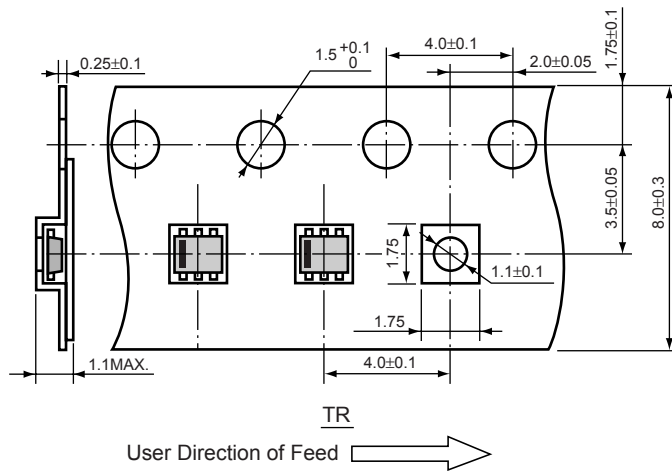

TAPING REEL DIMENSIONS

(1reel=4000pcs)

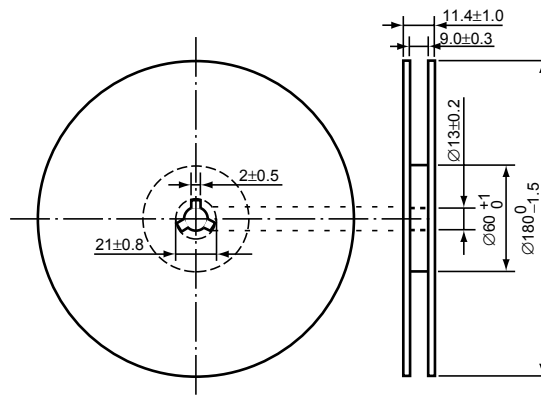

Power Dissipation (SON1612-6)

This specification is at mounted on board.

Power Dissipation (P_D) depends on conditions of mounting on board. This specification is based on the measurement at the condition below:

Measurement Conditions

	Standard Land Pattern
Environment	Mounting on Board (Wind velocity=0m/s)
Board Material	Glass cloth epoxy plastic (Double sided)
Board Dimensions	40mm × 40mm × 1.6mm
Copper Ratio	Top side : Approx. 50%, Back side : Approx.50%
Through-hole	φ0.5mm × 24pcs

Measurement Result

($T_{opt}=25^{\circ}C, T_{jmax}=125^{\circ}C$)

	Standard Land Pattern
Power Dissipation	500mW
Thermal Resistance	$\theta_{ja}=(125-25^{\circ}C)/0.5W=200^{\circ}C/W$

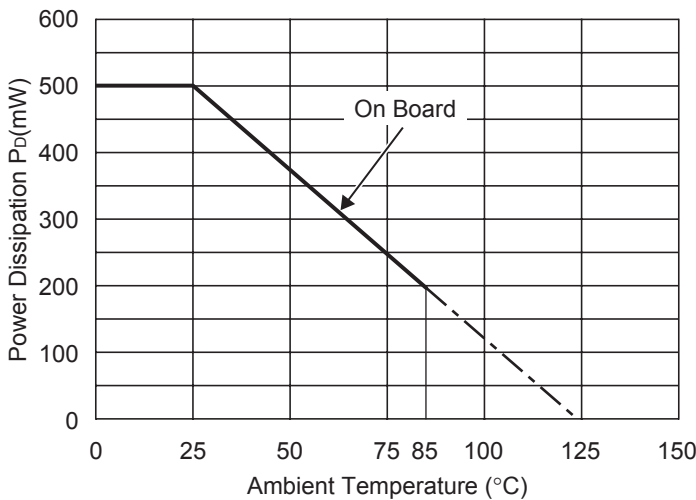

Power Dissipation

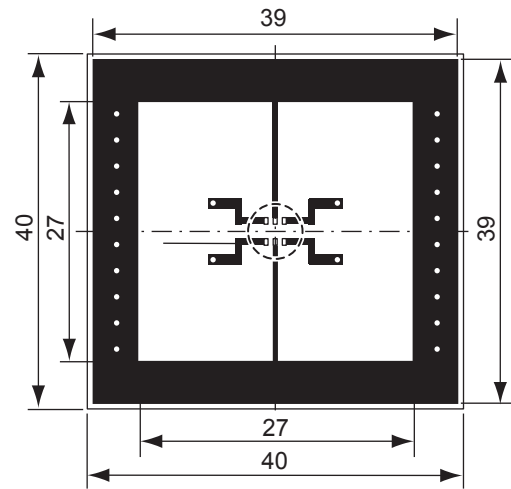

Measurement Board Pattern

○ IC Mount Area Unit : mm

RECOMMENDED LAND PATTERN

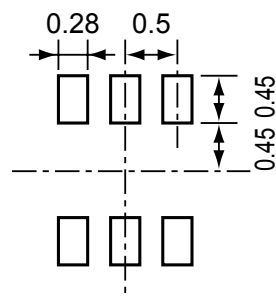

(Unit: mm)

R1116N SERIES MARK SPECIFICATION

● **SOT-23-5 (SC-74A)**

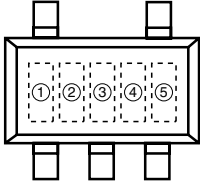

①, ②, ③ : Product Code (refer to Part Number vs. Product Code)

④, ⑤ : Lot Number (④, ⑤ : alphabetic character)

● **Part Number vs. Product Code**

Part Number	Product Code		
	①	②	③
R1116N151B	0	1	5
R1116N161B	0	1	6
R1116N171B	0	1	7
R1116N181B	0	1	8
R1116N191B	0	1	9
R1116N201B	0	2	0
R1116N211B	0	2	1
R1116N221B	0	2	2
R1116N231B	0	2	3
R1116N241B	0	2	4
R1116N251B	0	2	5
R1116N261B	0	2	6
R1116N271B	0	2	7
R1116N281B	0	2	8
R1116N291B	0	2	9
R1116N301B	0	3	0
R1116N311B	0	3	1
R1116N321B	0	3	2
R1116N331B	0	3	3
R1116N341B	0	3	4
R1116N351B	0	3	5
R1116N361B	0	3	6
R1116N371B	0	3	7
R1116N381B	0	3	8
R1116N391B	0	3	9
R1116N401B	0	4	0
R1116N181D5	0	4	1
R1116N281D5	0	4	2

Part Number	Product Code		
	①	②	③
R1116N151D	1	1	5
R1116N161D	1	1	6
R1116N171D	1	1	7
R1116N181D	1	1	8
R1116N191D	1	1	9
R1116N201D	1	2	0
R1116N211D	1	2	1
R1116N221D	1	2	2
R1116N231D	1	2	3
R1116N241D	1	2	4
R1116N251D	1	2	5
R1116N261D	1	2	6
R1116N271D	1	2	7
R1116N281D	1	2	8
R1116N291D	1	2	9
R1116N301D	1	3	0
R1116N311D	1	3	1
R1116N321D	1	3	2
R1116N331D	1	3	3
R1116N341D	1	3	4
R1116N351D	1	3	5
R1116N361D	1	3	6
R1116N371D	1	3	7
R1116N381D	1	3	8
R1116N391D	1	3	9
R1116N401D	1	4	0
R1116N181D5	1	4	1
R1116N281D5	1	4	2

R1116D SERIES MARK SPECIFICATION

● SON1612-6

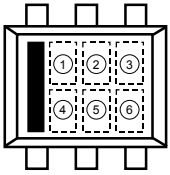

①~④ : Product Code (refer to Part Number vs. Product Code)

⑤, ⑥ : Lot Number

● Part Number vs. Product Code

Part Number	Product Code			
	①	②	③	④
R1116D151B	K	1	5	B
R1116D161B	K	1	6	B
R1116D171B	K	1	7	B
R1116D181B	K	1	8	B
R1116D191B	K	1	9	B
R1116D201B	K	2	0	B
R1116D211B	K	2	1	B
R1116D221B	K	2	2	B
R1116D231B	K	2	3	B
R1116D241B	K	2	4	B
R1116D251B	K	2	5	B
R1116D261B	K	2	6	B
R1116D271B	K	2	7	B
R1116D281B	K	2	8	B
R1116D291B	K	2	9	B
R1116D301B	K	3	0	B
R1116D311B	K	3	1	B
R1116D321B	K	3	2	B
R1116D331B	K	3	3	B
R1116D341B	K	3	4	B
R1116D351B	K	3	5	B
R1116D361B	K	3	6	B
R1116D371B	K	3	7	B
R1116D381B	K	3	8	B
R1116D391B	K	3	9	B
R1116D401B	K	4	0	B
R1116D181B5	K	4	1	B
R1116D281B5	K	4	2	B

Part Number	Product Code			
	①	②	③	④
R1116D151D	K	1	5	D
R1116D161D	K	1	6	D
R1116D171D	K	1	7	D
R1116D181D	K	1	8	D
R1116D191D	K	1	9	D
R1116D201D	K	2	0	D
R1116D211D	K	2	1	D
R1116D221D	K	2	2	D
R1116D231D	K	2	3	D
R1116D241D	K	2	4	D
R1116D251D	K	2	5	D
R1116D261D	K	2	6	D
R1116D271D	K	2	7	D
R1116D281D	K	2	8	D
R1116D291D	K	2	9	D
R1116D301D	K	3	0	D
R1116D311D	K	3	1	D
R1116D321D	K	3	2	D
R1116D331D	K	3	3	D
R1116D341D	K	3	4	D
R1116D351D	K	3	5	D
R1116D361D	K	3	6	D
R1116D371D	K	3	7	D
R1116D381D	K	3	8	D
R1116D391D	K	3	9	D
R1116D401D	K	4	0	D
R1116D181D5	K	4	1	D
R1116D281D5	K	4	2	D



Компания «ЭлектроПласт» предлагает заключение долгосрочных отношений при поставках импортных электронных компонентов на взаимовыгодных условиях!

Наши преимущества:

- Оперативные поставки широкого спектра электронных компонентов отечественного и импортного производства напрямую от производителей и с крупнейших мировых складов;
- Поставка более 17-ти миллионов наименований электронных компонентов;
- Поставка сложных, дефицитных, либо снятых с производства позиций;
- Оперативные сроки поставки под заказ (от 5 рабочих дней);
- Экспресс доставка в любую точку России;
- Техническая поддержка проекта, помощь в подборе аналогов, поставка прототипов;
- Система менеджмента качества сертифицирована по Международному стандарту ISO 9001;
- Лицензия ФСБ на осуществление работ с использованием сведений, составляющих государственную тайну;
- Поставка специализированных компонентов (Xilinx, Altera, Analog Devices, Intersil, Interpoint, Microsemi, Aeroflex, Peregrine, Syfer, Eurofarad, Texas Instrument, Miteq, Cobham, E2V, MA-COM, Hittite, Mini-Circuits, General Dynamics и др.);

Помимо этого, одним из направлений компании «ЭлектроПласт» является направление «Источники питания». Мы предлагаем Вам помощь Конструкторского отдела:

- Подбор оптимального решения, техническое обоснование при выборе компонента;
- Подбор аналогов;
- Консультации по применению компонента;
- Поставка образцов и прототипов;
- Техническая поддержка проекта;
- Защита от снятия компонента с производства.



Как с нами связаться

Телефон: 8 (812) 309 58 32 (многоканальный)

Факс: 8 (812) 320-02-42

Электронная почта: org@eplast1.ru

Адрес: 198099, г. Санкт-Петербург, ул. Калинина, дом 2, корпус 4, литера А.