

Wirewound Resistors, Industrial Power, Silicone Coated, Printed Circuit Board Mount

FEATURES

- High temperature silicone coating
- Eliminates lead forming to keep parts off of PC board
- Built in standoffs provide PC board heat protection and opposing feet to avoid rocking
- Available in non-inductive style (special "NI") with Ayrton-Perry winding
- Material categorization: for definitions of compliance please see www.vishay.com/doc?99912

RoHS
COMPLIANT

STANDARD ELECTRICAL SPECIFICATIONS

GLOBAL MODEL	HISTORICAL MODEL	POWER RATING $P_{25^{\circ}\text{C}}$ W	RESISTANCE RANGE Ω $\pm 5\%$	RESISTANCE RANGE Ω $\pm 10\%$	WEIGHT (typical) g
FS-003	FS-3	3	1.0 to 6K	0.1 to 6K	1.16
FS-05A	FS-5A	5	1.0 to 15K	0.1 to 15K	2.12
FS-005	FS-5	7	1.0 to 17.5K	0.1 to 17.5K	3.36
FS-05S	FS-5S	8	1.0 to 20.5K	0.1 to 20.5K	4.60
FS-010	FS-10	10	1.0 to 29K	0.1 to 29K	6.24
FS-10S	FS-10S	12	1.0 to 58K	0.1 to 58K	6.60
FS-020	FS-20	20	1.0 to 60K	0.1 to 60K	8.82
FS-20S	FS-20S	20	1.0 to 95K	0.1 to 95K	11.36

TECHNICAL SPECIFICATIONS

PARAMETER	UNIT	FS RESISTOR CHARACTERISTICS
Temperature Coefficient	ppm/°C	± 260 for 20 Ω and above, ± 400 for 1 Ω to 19.99 Ω , special TC's available please contact factory
Short Time Overload	-	10 x rated power for 5 s
Dielectric Withstanding Voltage	V _{AC}	1000, from terminal to mounting hardware
Maximum Working Voltage	V	$(P \times R)^{1/2}$
Operating Temperature Range	°C	-55 to +350

GLOBAL PART NUMBER INFORMATION

 Global Part Numbering example: **FS-010CBE1K000JE** (visit www.vishay.net SAP parts manual for all options)

F	S	-	0	1	0	C	B	E	1	K	0	0	0	J	E		
---	---	---	---	---	---	---	---	---	---	---	---	---	---	---	---	--	--

GLOBAL MODEL (6 digits)	TERMINAL DESIGNATION (2 digits)	TERMINAL FINISH (1 digit)	VALUE (5 digits)	TOLERANCE (1 digit)	PACKAGING CODE (1 digit)	SPECIAL (up to 2 digits)
(see Standard Electrical Specifications Global Model column for options)	CB	E = lead (Pb)-free	R = decimal K = thousand 1R500 = 1.5 Ω 1K500 = 1.5 k Ω	J = $\pm 5\%$ K = $\pm 10\%$	E = lead (Pb)-free cell and bulk pack	(dash number) from 1 to 99 as applicable NI = non-inductive

 Historical Part Number example: **FS-10-1K-5 %**

FS-10	1K Ω	5 %	
HISTORICAL MODEL	RESISTANCE VALUE	TOLERANCE	SPECIAL

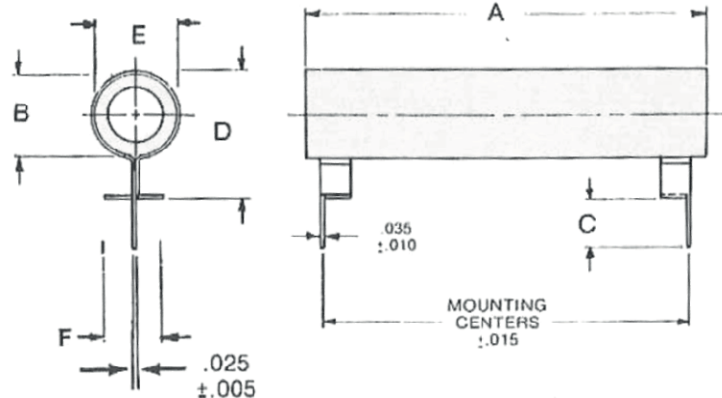
DIMENSIONS in inches [millimeters]

Note

- Recommended mounting hole is 0.078 diameter.

MODEL	DIMENSIONS in inches [millimeters]						
	CORE		C ± 0.062 [± 1.57]	D MAX.	E MAX.	F MAX.	STANDARD MOUNTING CENTERS ± 0.015 [± 0.381]
	A ± 0.062 [± 1.57]	B ± 0.031 [± 0.78]					
FS-003	1.000	0.200	0.360	0.450	0.281	0.400	0.600
FS-002	[25.4]	[5.08]	[9.14]	[11.43]	[7.14]	[10.16]	[15.24]
FS-05A	1.125	0.200	0.360	0.450	0.281	0.400	0.900
	[28.58]	[5.08]	[9.14]	[11.43]	[7.14]	[10.16]	[22.86]
FS-005	1.000	0.312	0.360	0.600	0.410	0.500	0.600
FS-006	[25.4]	[7.94]	[9.14]	[15.24]	[10.41]	[12.7]	[15.24]
FS-05S	1.125	0.312	0.360	0.600	0.410	0.500	0.900
	[28.58]	[7.94]	[9.14]	[15.24]	[10.41]	[12.7]	[22.86]
FS-010	1.750	0.312	0.360	0.600	0.410	0.500	1.300
	[44.45]	[7.94]	[9.14]	[15.24]	[10.41]	[12.7]	[33.02]
FS-10S	2.125	0.312	0.360	0.600	0.410	0.500	1.700
	[53.98]	[7.94]	[9.14]	[15.24]	[10.41]	[12.7]	[43.18]
FS-015	2.000	0.437	0.19	0.725	0.531	0.531	1.700
FS-020	[50.8]	[11.11]	[4.82]	[18.41]	[13.49]	[13.49]	[43.18]
FS-20S	2.375	0.437	0.19	0.725	0.531	0.531	2.200
	[9.53]	[11.11]	[4.82]	[18.41]	[13.49]	[13.49]	[55.88]

Notes

- The pin configuration on the terminals for the FS-10S and smaller products is on the center of the terminal.
- The pin configuration on the terminals for the FS-015 and larger products is on the edge of the terminal

MATERIAL SPECIFICATIONS

Element: Copper-nickel alloy or nickel-chrome alloy, depending on resistance value

Core: Ceramic, steatite

Coating: Special high temperature silicone

Standard Terminals: Tinned alloy 42

Terminal Bands: Alloy 42

Part Marking: HEI, model, wattage, value, tolerance, date code

NON-INDUCTIVE

Models of equivalent physical and electrical specifications are available with non-inductive (Ayrton-Perry) winding. They are identified by adding the letters "NI" to the end of the part number in the special section. For non-inductive models the maximum resistance values are one-half the standard part.

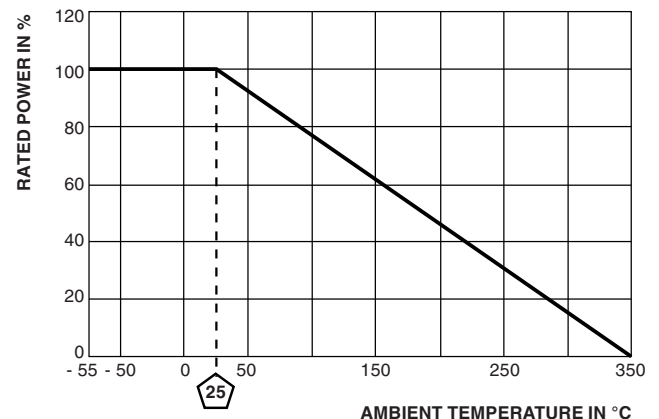
DERATING



Disclaimer

ALL PRODUCT, PRODUCT SPECIFICATIONS AND DATA ARE SUBJECT TO CHANGE WITHOUT NOTICE TO IMPROVE RELIABILITY, FUNCTION OR DESIGN OR OTHERWISE.

Vishay Intertechnology, Inc., its affiliates, agents, and employees, and all persons acting on its or their behalf (collectively, "Vishay"), disclaim any and all liability for any errors, inaccuracies or incompleteness contained in any datasheet or in any other disclosure relating to any product.

Vishay makes no warranty, representation or guarantee regarding the suitability of the products for any particular purpose or the continuing production of any product. To the maximum extent permitted by applicable law, Vishay disclaims (i) any and all liability arising out of the application or use of any product, (ii) any and all liability, including without limitation special, consequential or incidental damages, and (iii) any and all implied warranties, including warranties of fitness for particular purpose, non-infringement and merchantability.

Statements regarding the suitability of products for certain types of applications are based on Vishay's knowledge of typical requirements that are often placed on Vishay products in generic applications. Such statements are not binding statements about the suitability of products for a particular application. It is the customer's responsibility to validate that a particular product with the properties described in the product specification is suitable for use in a particular application. Parameters provided in datasheets and / or specifications may vary in different applications and performance may vary over time. All operating parameters, including typical parameters, must be validated for each customer application by the customer's technical experts. Product specifications do not expand or otherwise modify Vishay's terms and conditions of purchase, including but not limited to the warranty expressed therein.

Except as expressly indicated in writing, Vishay products are not designed for use in medical, life-saving, or life-sustaining applications or for any other application in which the failure of the Vishay product could result in personal injury or death. Customers using or selling Vishay products not expressly indicated for use in such applications do so at their own risk. Please contact authorized Vishay personnel to obtain written terms and conditions regarding products designed for such applications.

No license, express or implied, by estoppel or otherwise, to any intellectual property rights is granted by this document or by any conduct of Vishay. Product names and markings noted herein may be trademarks of their respective owners.



Компания «ЭлектроПласт» предлагает заключение долгосрочных отношений при поставках импортных электронных компонентов на взаимовыгодных условиях!

Наши преимущества:

- Оперативные поставки широкого спектра электронных компонентов отечественного и импортного производства напрямую от производителей и с крупнейших мировых складов;
- Поставка более 17-ти миллионов наименований электронных компонентов;
- Поставка сложных, дефицитных, либо снятых с производства позиций;
- Оперативные сроки поставки под заказ (от 5 рабочих дней);
- Экспресс доставка в любую точку России;
- Техническая поддержка проекта, помощь в подборе аналогов, поставка прототипов;
- Система менеджмента качества сертифицирована по Международному стандарту ISO 9001;
- Лицензия ФСБ на осуществление работ с использованием сведений, составляющих государственную тайну;
- Поставка специализированных компонентов (Xilinx, Altera, Analog Devices, Intersil, Interpoint, Microsemi, Aeroflex, Peregrine, Syfer, Eurofarad, Texas Instrument, Miteq, Cobham, E2V, MA-COM, Hittite, Mini-Circuits, General Dynamics и др.);

Помимо этого, одним из направлений компании «ЭлектроПласт» является направление «Источники питания». Мы предлагаем Вам помощь Конструкторского отдела:

- Подбор оптимального решения, техническое обоснование при выборе компонента;
- Подбор аналогов;
- Консультации по применению компонента;
- Поставка образцов и прототипов;
- Техническая поддержка проекта;
- Защита от снятия компонента с производства.



Как с нами связаться

Телефон: 8 (812) 309 58 32 (многоканальный)

Факс: 8 (812) 320-02-42

Электронная почта: org@eplast1.ru

Адрес: 198099, г. Санкт-Петербург, ул. Калинина, дом 2, корпус 4, литера А.