

NB7V52M

1.8V / 2.5V Differential D Flip-Flop w/ Reset and CML Outputs

Multi-Level Inputs w/ Internal Termination

Description

The NB7V52M is a 10 GHz differential D flip-flop with a differential asynchronous Reset. The differential D/ \bar{D} , CLK/ \bar{CLK} and R/ \bar{R} inputs incorporate dual internal 50 Ω termination resistors and will accept LVPECL, CML, LVDS logic levels.

When Clock transitions from logic Low to High, Data will be transferred to the differential CML outputs. The differential Clock inputs allow the NB7V52M to also be used as a negative edge triggered device.

The 16 mA differential CML outputs provide matching internal 50 Ω termination and produce 400 mV output swings when externally receiver terminated with a 50 Ω resistor to V_{CC} .

The NB7V52M is offered in a low profile 3 mm x 3 mm 16-pin QFN package. The NB7V52M is a member of the GigaComm™ family of high performance clock products. Application notes, models, and support documentation are available at www.onsemi.com.

Features

- Maximum Input Clock Frequency > 10 GHz
- Maximum Input Data Rate > 10 Gb/s
- Random Clock Jitter < 0.8 ps RMS, Max
- 200 ps Typical Propagation Delay
- 35 ps Typical Rise and Fall Times
- Differential CML Outputs, 400 mV Peak-to-Peak, Typical
- Operating Range: $V_{CC} = 1.71$ V to 2.625 V with $V_{EE} = 0$ V
- Internal 50 Ω Input Termination Resistors
- QFN-16 Package, 3mm x 3mm
- -40°C to +85°C Ambient Operating Temperature
- These are Pb-Free Devices



ON Semiconductor®

<http://onsemi.com>

MARKING DIAGRAM*



QFN-16
MN SUFFIX
CASE 485G

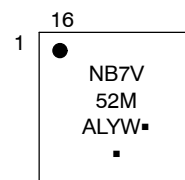

A = Assembly Location
L = Wafer Lot
Y = Year
W = Work Week
▪ = Pb-Free Package
(Note: Microdot may be in either location)

*For additional marking information, refer to Application Note AND8002/D.

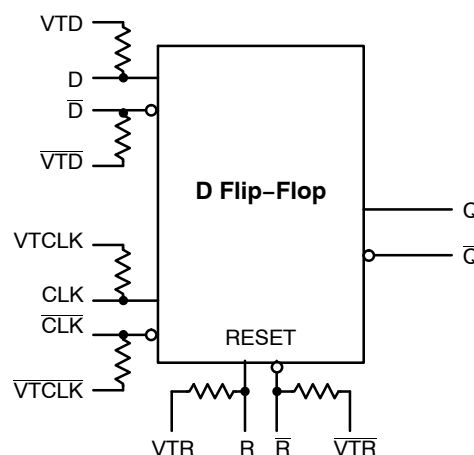

Figure 1. Logic Diagram

ORDERING INFORMATION

See detailed ordering and shipping information in the package dimensions section on page 9 of this data sheet.

NB7V52M

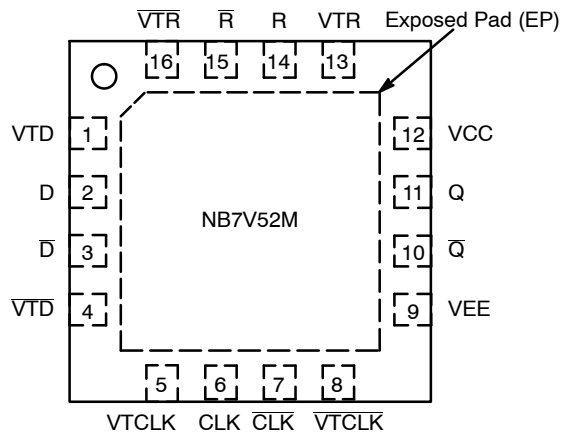

Figure 2. Pin Configuration (Top View)

Table 1. INPUT/OUTPUT SELECT TRUTH TABLE

R	D	CLK	Q
H	x	x	L
L	L	Z	L
L	H	Z	H

Z = LOW to HIGH Transition
x = Don't care

Table 1. Pin Description

Pin	Name	I/O	Description
1	VTD	-	Internal 50 Ω Termination Pin for D
2	D	LVPECL, CML, LVDS Input	Noninverted Differential Data Input. (Note 1)
3	\bar{D}	LVPECL, CML, LVDS Input	Inverted Differential Data Input. (Note 1)
4	\bar{VTD}	-	Internal 50 Ω Termination Pin for \bar{D}
5	VTCLK	-	Internal 50 Ω Termination Pin for CLK
6	CLK	LVPECL, CML, LVDS Input	Noninverted Differential Clock Input. (Note 1)
7	\bar{CLK}	LVPECL, CML, LVDS Input	Inverted Differential Clock Input. (Note 1)
8	\bar{VTCLK}	-	Internal 50 Ω Termination Pin for \bar{CLK}
9	VEE	-	Negative Supply Voltage. (Note 2)
10	\bar{Q}	CML Output	Inverted Differential Output
11	Q	CML Output	Noninverted Differential Output
12	VCC	-	Positive Supply Voltage. (Note 2)
13	VTR	-	Internal 50 Ω Termination Pin for R
14	R	LVPECL, CML, LVDS Input	Noninverted Asynchronous Differential Reset Input. (Note 1)
15	\bar{R}	LVPECL, CML, LVDS Input	Inverted Asynchronous Differential Reset Input. (Note 1)
16	\bar{VTR}	-	Internal 50 Ω Termination Pin for \bar{R}
-	EP	-	The Exposed Pad (EP) on the QFN-16 package bottom is thermally connected to the die for improved heat transfer out of package. The exposed pad must be attached to a heat-sinking conduit. The pad is not electrically connected to the die, but is recommended to be electrically and thermally connected to VEE on the PC board.

1. In the differential configuration when the input termination pins (\bar{VTx} , \bar{VTx}) are connected to a common termination voltage or left open, and if no signal is applied on CLK/ \bar{CLK} input, then the device will be susceptible to self-oscillation.
2. All VCC and GND pins must be externally connected to a power supply for proper operation.

NB7V52M

Table 2. ATTRIBUTES

Characteristics		Value
ESD Protection	Human Body Model Machine Model	> 2 kV > 200 V
Moisture Sensitivity	16-QFN	Level 1
Flammability Rating	Oxygen Index: 28 to 34	UL 94 V-0 @ 0.125 in
Transistor Count		173
Meets or exceeds JEDEC Spec EIA/JESD78 IC Latchup Test		

For additional information, see Application Note AND8003/D.

Table 3. MAXIMUM RATINGS

Symbol	Parameter	Condition 1	Condition 2	Rating	Unit
V _{CC}	Positive Power Supply	V _{EE} = 0 V		3.0	V
V _{IO}	Positive Input/Output Voltage	V _{EE} = 0 V	-0.5 ≤ V _{IO} ≤ V _{CC} + 0.5	-0.5 to V _{CC} + 0.5	V
V _{INPP}	Differential Input Voltage CLK - $\overline{\text{CLK}}$, D - $\overline{\text{D}}$, R - $\overline{\text{R}}$			1.89	V
I _{OUT}	Output Current Through R _{TOUT} (50 Ω Resistor)	Continuous Surge		34 40	mA
I _{IN}	Input Current Through R _{TIN} (50 Ω Resistor)			± 40	mA
T _A	Operating Temperature Range			-40 to +85	°C
T _{stg}	Storage Temperature Range			-65 to +150	°C
θ _{JA}	Thermal Resistance (Junction-to-Ambient) (Note 3)	0 lfpm 500 lfpm	QFN-16 QFN-16	42 35	°C/W °C/W
θ _{JC}	Thermal Resistance (Junction-to-Case) (Note 3)		QFN-16	4	°C/W
T _{sol}	Wave Solder Pb-Free			265	°C

Stresses exceeding Maximum Ratings may damage the device. Maximum Ratings are stress ratings only. Functional operation above the Recommended Operating Conditions is not implied. Extended exposure to stresses above the Recommended Operating Conditions may affect device reliability.

3. JEDEC standard multilayer board – 2S2P (2 signal, 2 power) with 8 filled thermal vias under exposed pad.

NB7V52M

Table 4. DC CHARACTERISTICS, Multi-Level Inputs $V_{CC} = 1.71\text{ V to }2.625\text{ V}$, $V_{EE} = 0\text{ V}$, $T_A = -40^\circ\text{C to }+85^\circ\text{C}$ (Note 4)

Symbol	Characteristic	Min	Typ	Max	Unit
POWER SUPPLY CURRENT					
I_{CC}	Power Supply Current (Inputs and Outputs Open) $V_{CC} = 2.5\text{ V}$ $V_{CC} = 1.8\text{ V}$		90 70	110 90	mA
CML OUTPUTS					
V_{OH}	Output HIGH Voltage (Note 5) $V_{CC} = 2.5\text{ V}$ $V_{CC} = 1.8\text{ V}$	$V_{CC} - 30$ 2470 1770	$V_{CC} - 10$ 2490 1790	V_{CC} 2500 1800	mV
V_{OL}	Output LOW Voltage (Note 5) $V_{CC} = 2.5\text{ V}$ $V_{CC} = 1.8\text{ V}$	$V_{CC} - 650$ 1850	$V_{CC} - 500$ 2000	$V_{CC} - 400$ 2100	mV
		$V_{CC} - 600$ 1200	$V_{CC} - 450$ 1350	$V_{CC} - 350$ 1450	
DIFFERENTIAL CLOCK INPUTS DRIVEN SINGLE-ENDED (Note 6) (Figures 5 and 7)					
V_{th}	Input Threshold Reference Voltage Range (Note 7)	1000		$V_{CC} - 100$	mV
V_{IH}	Single-Ended Input HIGH Voltage	$V_{th} + 100$		V_{CC}	mV
V_{IL}	Single-Ended Input LOW Voltage	V_{EE}		$V_{th} - 100$	mV
V_{ISE}	Single-Ended Input Voltage ($V_{IH} - V_{IL}$)	200		1200	mV
DIFFERENTIAL D/D, CLK/CLK, R/R INPUTS DRIVEN DIFFERENTIALLY (Figures 6 and 8) (Note 8)					
V_{IHD}	Differential Input HIGH Voltage	1100		V_{CC}	mV
V_{ILD}	Differential Input LOW Voltage	V_{EE}		$V_{CC} - 100$	mV
V_{ID}	Differential Input Voltage ($V_{IHD} - V_{ILD}$)	100		1200	mV
V_{CMR}	Input Common Mode Range (Differential Configuration, Note 9) (Figure 10)	1050		$V_{CC} - 50$	mV
I_{IH}	Input HIGH Current (V_{TX}/V_{TX} Open)	-250		250	μA
I_{IL}	Input LOW Current (V_{TX}/V_{TX} Open)	-250		250	μA
TERMINATION RESISTORS					
R_{TIN}	Internal Input Termination Resistor	45	50	55	Ω
R_{TOUT}	Internal Output Termination Resistor	45	50	55	Ω

NOTE: Device will meet the specifications after thermal equilibrium has been established when mounted in a test socket or printed circuit board with maintained transverse airflow greater than 500 lfm. Electrical parameters are guaranteed only over the declared operating temperature range. Functional operation of the device exceeding these conditions is not implied. Device specification limit values are applied individually under normal operating conditions and not valid simultaneously.

- Input and output parameters vary 1:1 with V_{CC} .
- CML outputs loaded with $50\ \Omega$ to V_{CC} for proper operation.
- V_{th} , V_{IH} , V_{IL} , and V_{ISE} parameters must be complied with simultaneously.
- V_{th} is applied to the complementary input when operating in single-ended mode.
- V_{IHD} , V_{ILD} , V_{ID} and V_{CMR} parameters must be complied with simultaneously.
- V_{CMR} min varies 1:1 with V_{EE} , V_{CMR} max varies 1:1 with V_{CC} . The V_{CMR} range is referenced to the most positive side of the differential input signal.

NB7V52M

Table 5. AC CHARACTERISTICS $V_{CC} = 1.71\text{ V to }2.625\text{ V}$; $V_{EE} = 0\text{ V}$; $T_A = -40^\circ\text{C to }85^\circ\text{C}$ (Note 10)

Symbol	Characteristic	Min	Typ	Max	Unit	
f_{MAX}	Maximum Input Clock Frequency	10	12		GHz	
$f_{DATA\ MAX}$	Maximum Input Data Rate (PRBS23)	10	12		Gbps	
V_{OUTPP}	Output Voltage Amplitude (@ $V_{INPPmin}$) (See Figures 3 and 10, Note 11)	$f_{in} \leq 7\text{ GHz}$ 300 $f_{in} \leq 10\text{ GHz}$ 250	400 400		mV	
t_{PLH} , t_{PHL}	Propagation Delay to Differential Outputs, @ 1 GHz, Measured at Differential Cross-point	CLK/ \overline{CLK} to Q/ \overline{Q} R/ \overline{R} to Q/ \overline{Q}	200 300	350 600	ps	
t_S	Setup Time (D to CLK)	40	15		ps	
t_H	Hold Time (D to CLK)	50	20		ps	
t_{RR}	Reset Recovery	275	200		ps	
t_{PW}	Minimum Pulse Width	R/ \overline{R}	1		ns	
t_{JITTER}	RJ – Output Random Jitter (Note 12)	$f_{in} \leq 10\text{ GHz}$	0.2	0.8	ps RMS	
V_{INPP}	Input Voltage Swing (Differential Configuration) (Note 13)	100		1200	mV	
t_r , t_f	Output Rise/Fall Times @ 1 GHz (20% – 80%),	Q, \overline{Q}	20	35	50	ps

NOTE: Device will meet the specifications after thermal equilibrium has been established when mounted in a test socket or printed circuit board with maintained transverse airflow greater than 500 lfpm. Electrical parameters are guaranteed only over the declared operating temperature range. Functional operation of the device exceeding these conditions is not implied. Device specification limit values are applied individually under normal operating conditions and not valid simultaneously.

10. Measured using a 400 mV V_{INPP} source, 50% duty cycle clock source. All output loading with external $50\ \Omega$ to V_{CC} . Input edge rates $\geq 40\text{ ps}$ (20% – 80%).

11. Output voltage swing is a single-ended measurement operating in differential mode.

12. Additive RMS jitter with 50% duty cycle clock signal.

13. Input voltage swing is a single-ended measurement operating in differential mode.

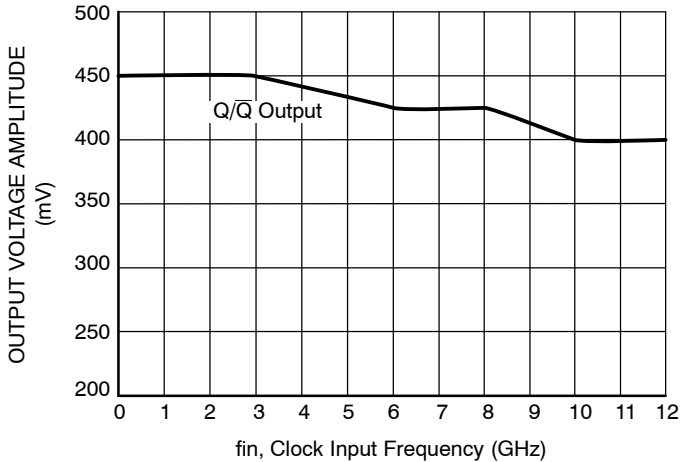

Figure 3. Clock Output Voltage Amplitude (V_{OUTPP}) vs. Input Frequency (f_{in}) at Ambient Temperature (Typ)

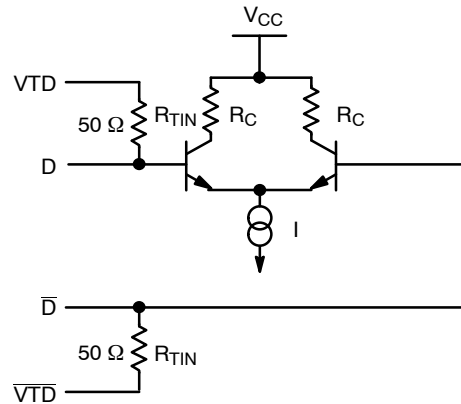

Figure 4. Simplified Input Structure

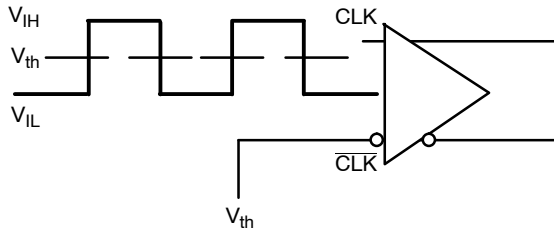

Figure 5. Differential Input Driven Single-Ended

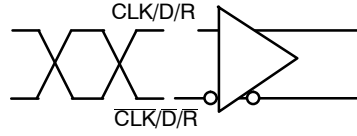

Figure 6. Differential Inputs Driven Differentially

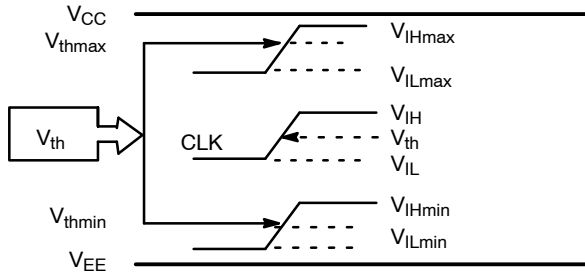

Figure 7. V_{th} Diagram

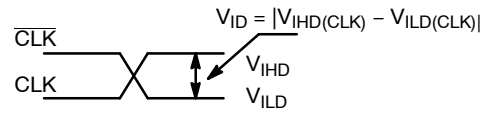

Figure 8. Differential Inputs Driven Differentially

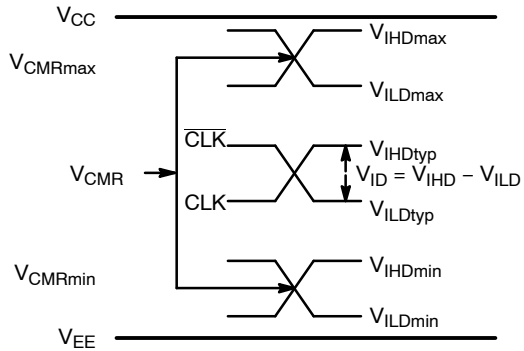

Figure 9. V_{CMR} Diagram

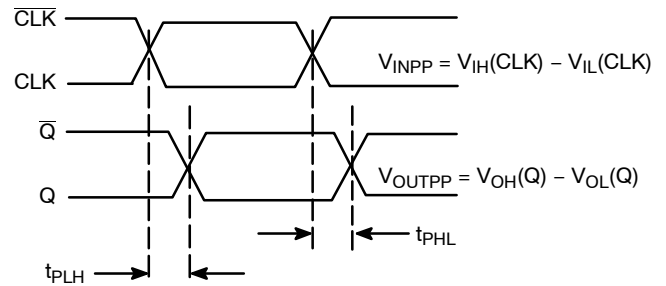

Figure 10. AC Reference Measurement

NB7V52M

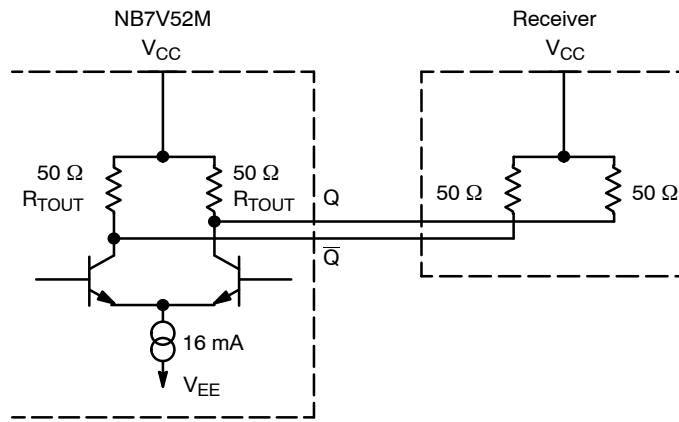

Figure 11. Typical CML Output Structure and Termination

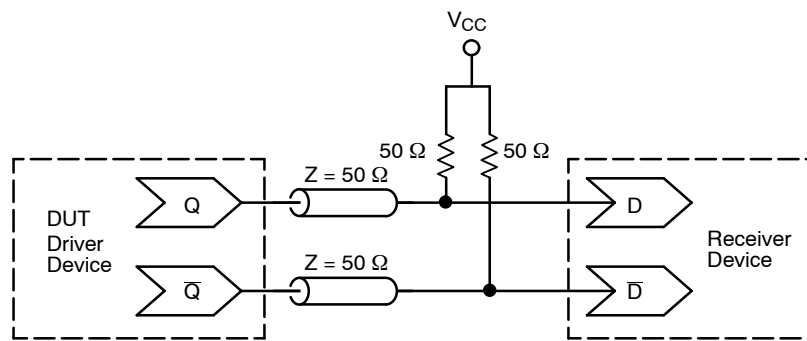

Figure 12. Typical Termination for CML Output Driver and Device Evaluation

NB7V52M

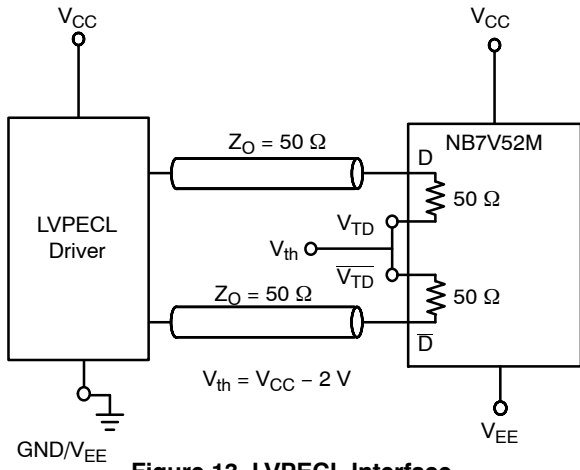

Figure 13. LVPECL Interface

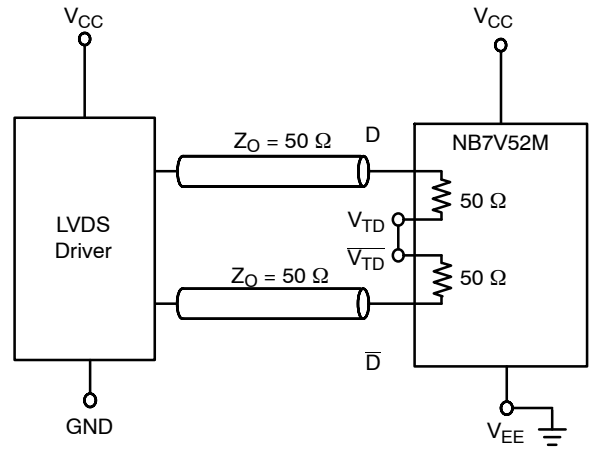

Figure 14. LVDS Interface

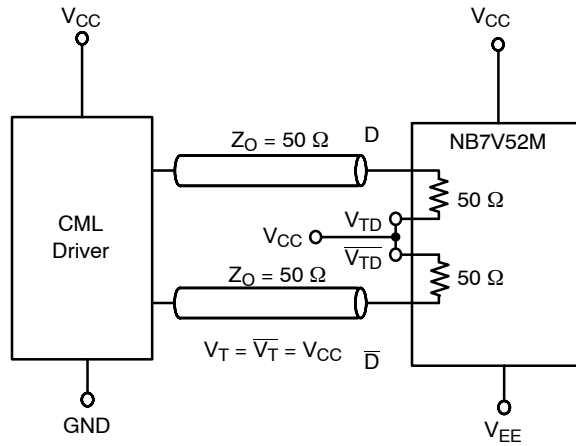

Figure 15. Standard 50 Ω Load CML Interface

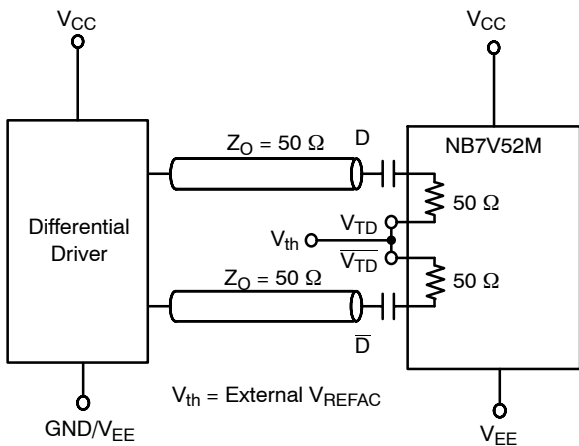

Figure 16. Capacitor-Coupled Differential Interface ($V_T/\overline{V_T}$ Connected to External V_{REFAC} ; V_{REFAC} Bypassed to Ground with 0.1 μF Capacitor)

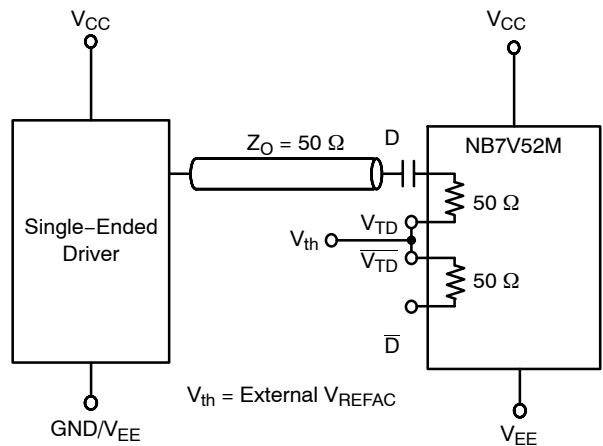

Figure 17. Capacitor-Coupled Single-Ended Interface ($V_T/\overline{V_T}$ Connected to External V_{REFAC} ; V_{REFAC} Bypassed to Ground with 0.1 μF Capacitor)

NB7V52M

ORDERING INFORMATION

Device	Package	Shipping†
NB7V52MMNG	QFN-16 (Pb-free)	123 Units / Rail
NB7V52MMNHTBG	QFN-16 (Pb-free)	100 / Tape & Reel
NB7V52MMNTXG	QFN-16 (Pb-free)	3000 / Tape & Reel

†For information on tape and reel specifications, including part orientation and tape sizes, please refer to our Tape and Reel Packaging Specifications Brochure, BRD8011/D.

NB7V52M

PACKAGE DIMENSIONS

16 PIN QFN CASE 485G-01 ISSUE D

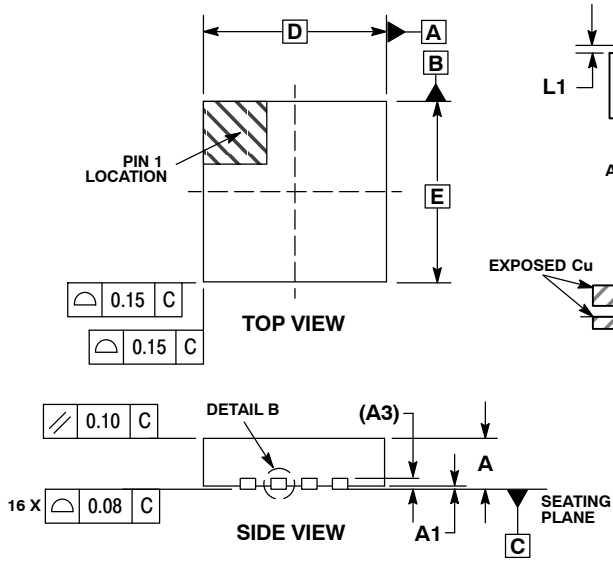

- NOTES:
1. DIMENSIONING AND TOLERANCING PER ASME Y14.5M, 1994.
 2. CONTROLLING DIMENSION: MILLIMETERS.
 3. DIMENSION b APPLIES TO PLATED TERMINAL AND IS MEASURED BETWEEN 0.25 AND 0.30 MM FROM TERMINAL.
 4. COPLANARITY APPLIES TO THE EXPOSED PAD AS WELL AS THE TERMINALS.
 5. L_{max} CONDITION CAN NOT VIOLATE 0.2 MM MINIMUM SPACING BETWEEN LEAD TIP AND FLAG

MILLIMETERS		
DIM	MIN	MAX
A	0.80	1.00
A1	0.00	0.05
A3	0.20	REF
b	0.18	0.30
D	3.00	BSC
D2	1.65	1.85
E	3.00	BSC
E2	1.65	1.85
e	0.50	BSC
K	0.18	TYP
L	0.30	0.50
L1	0.00	0.15

SOLDERING FOOTPRINT*

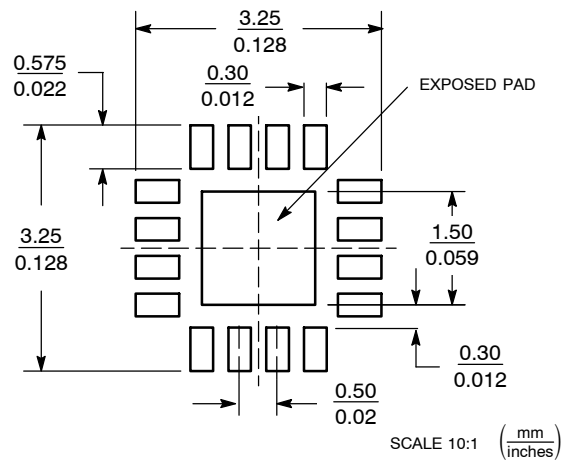

*For additional information on our Pb-Free strategy and soldering details, please download the ON Semiconductor Soldering and Mounting Techniques Reference Manual, SOLDERRM/D.

The products described herein (NB7V52M), may be covered by U.S. patents including 6,362,644. There may be other patents pending. GigaComm is a trademark of Semiconductor Components Industries, LLC (SCILLC).

ON Semiconductor and are registered trademarks of Semiconductor Components Industries, LLC (SCILLC). SCILLC reserves the right to make changes without further notice to any products herein. SCILLC makes no warranty, representation or guarantee regarding the suitability of its products for any particular purpose, nor does SCILLC assume any liability arising out of the application or use of any product or circuit, and specifically disclaims any and all liability, including without limitation special, consequential or incidental damages. "Typical" parameters which may be provided in SCILLC data sheets and/or specifications can and do vary in different applications and actual performance may vary over time. All operating parameters, including "Typicals" must be validated for each customer application by customer's technical experts. SCILLC does not convey any license under its patent rights nor the rights of others. SCILLC products are not designed, intended, or authorized for use as components in systems intended for surgical implant into the body, or other applications intended to support or sustain life, or for any other application in which the failure of the SCILLC product could create a situation where personal injury or death may occur. Should Buyer purchase or use SCILLC products for any such unintended or unauthorized application, Buyer shall indemnify and hold SCILLC and its officers, employees, subsidiaries, affiliates, and distributors harmless against all claims, costs, damages, and expenses, and reasonable attorney fees arising out of, directly or indirectly, any claim of personal injury or death associated with such unintended or unauthorized use, even if such claim alleges that SCILLC was negligent regarding the design or manufacture of the part. SCILLC is an Equal Opportunity/Affirmative Action Employer. This literature is subject to all applicable copyright laws and is not for resale in any manner.

PUBLICATION ORDERING INFORMATION

LITERATURE FULFILLMENT:
Literature Distribution Center for ON Semiconductor
P.O. Box 5163, Denver, Colorado 80217 USA
Phone: 303-675-2175 or 800-344-3860 Toll Free USA/Canada
Fax: 303-675-2176 or 800-344-3867 Toll Free USA/Canada
Email: orderlit@onsemi.com

N. American Technical Support: 800-282-9855 Toll Free USA/Canada
Japan: ON Semiconductor, Japan Customer Focus Center
2-9-1 Kamimeguro, Meguro-ku, Tokyo, Japan 153-0051
Phone: 81-3-5773-3850

ON Semiconductor Website: <http://onsemi.com>
Order Literature: <http://www.onsemi.com/litorder>

For additional information, please contact your local Sales Representative.



Компания «ЭлектроПласт» предлагает заключение долгосрочных отношений при поставках импортных электронных компонентов на взаимовыгодных условиях!

Наши преимущества:

- Оперативные поставки широкого спектра электронных компонентов отечественного и импортного производства напрямую от производителей и с крупнейших мировых складов;
- Поставка более 17-ти миллионов наименований электронных компонентов;
- Поставка сложных, дефицитных, либо снятых с производства позиций;
- Оперативные сроки поставки под заказ (от 5 рабочих дней);
- Экспресс доставка в любую точку России;
- Техническая поддержка проекта, помощь в подборе аналогов, поставка прототипов;
- Система менеджмента качества сертифицирована по Международному стандарту ISO 9001;
- Лицензия ФСБ на осуществление работ с использованием сведений, составляющих государственную тайну;
- Поставка специализированных компонентов (Xilinx, Altera, Analog Devices, Intersil, Interpoint, Microsemi, Aeroflex, Peregrine, Syfer, Eurofarad, Texas Instrument, Miteq, Cobham, E2V, MA-COM, Hittite, Mini-Circuits, General Dynamics и др.);

Помимо этого, одним из направлений компании «ЭлектроПласт» является направление «Источники питания». Мы предлагаем Вам помощь Конструкторского отдела:

- Подбор оптимального решения, техническое обоснование при выборе компонента;
- Подбор аналогов;
- Консультации по применению компонента;
- Поставка образцов и прототипов;
- Техническая поддержка проекта;
- Защита от снятия компонента с производства.



Как с нами связаться

Телефон: 8 (812) 309 58 32 (многоканальный)

Факс: 8 (812) 320-02-42

Электронная почта: org@eplast1.ru

Адрес: 198099, г. Санкт-Петербург, ул. Калинина, дом 2, корпус 4, литера А.