

Kinetis K21F Sub-Family Data Sheet

120 MHz ARM® Cortex®-M4-based Microcontroller with FPU

The K21 product family members are optimized for cost-sensitive applications requiring low-power, USB connectivity, processing efficiency with floating point unit and the need for extensive tamper protection, such as Electronic Point of Sales. It shares the comprehensive enablement and scalability of the Kinetis family. This product offers:

- Up to 1 MB of flash memory with up to 128 KB of SRAM
- Drylce Tamper Detection with active/passive pin, temperature, clock, supply voltage monitoring
- Run power consumption down to 279 μ A/MHz. Static power consumption down to 5.1 μ A with full state retention and 5 μ s wakeup. Lowest Static mode down to 268 nA
- USB LS/FS OTG 2.0 with embedded 3.3 V, 120 mA LDO voltage regulator

MK21FX512VLQ12
MK21FN1M0VLQ12
MK21FX512VMD12
MK21FN1M0VMD12

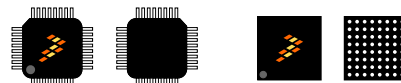

144 LQFP 20 x 20 x 1.6 mm Pitch 0.5 mm
144 BGA 13 x 13 x 1.7 mm Pitch 1 mm

Performance

- Up to 120 MHz ARM Cortex-M4-based core with DSP instructions delivering 1.25 Dhrystone MIPS per MHz

Memories and memory interfaces

- Up to 1 MB program flash memory and 128 KB RAM
- Up to 128 KB FlexNVM and 4 KB FlexRAM on FlexMemory devices
- FlexBus external bus interface

System peripherals

- Multiple low-power modes; low leakage wakeup unit
- Memory protection unit with multi-master protection
- 16-channel DMA controller
- External watchdog monitor and software watchdog

Security and integrity modules

- Hardware CRC module
- Tamper detect and secure storage
- Hardware random-number generator
- Hardware encryption
- 128-bit unique identification (ID) number per chip

Analog modules

- Two 16-bit SAR ADCs
- Two 12-bit DACs

Communication interfaces

- USB full-/low-speed On-the-Go controller
- USB Device Charger detect
- Controller Area Network (CAN) module
- Three SPI modules
- Three I2C modules
- Six UART modules
- Secure Digital host controller (SDHC)
- I2S module

Timers

- Two 8-channel Flex-Timers (PWM/Motor Control)
- Two 2-channel Flex-Timers (PWM/Quad Decoder)
- Periodic interrupt timers and 16-bit low-power timer
- Carrier modulator transmitter
- Real-time clock
- Programmable delay block

Clocks

- 3 to 32 MHz and 32 kHz crystal oscillator
- PLL, FLL, and multiple internal oscillators

Operating Characteristics

- Voltage range: 1.71 to 3.6 V
- Flash write voltage range: 1.71 to 3.6 V
- Temperature range (ambient): -40 to 105°C

- Three analog comparators (CMP)
- Voltage reference

Ordering Information ¹

| Part Number | Memory | | Maximum number of I/O's |
|----------------|------------|-----------|-------------------------|
| | Flash (KB) | SRAM (KB) | |
| MK21FX512VLQ12 | 512 KB | 128 | 104 |
| MK21FN1M0VLQ12 | 1 MB | 128 | 104 |
| MK21FX512VMD12 | 512 KB | 128 | 104 |
| MK21FN1M0VMD12 | 1 MB | 128 | 104 |

1. To confirm current availability of orderable part numbers, go to <http://www.freescale.com> and perform a part number search.

Related Resources

| Type | Description | Resource |
|------------------|--|--|
| Selector Guide | The Freescale Solution Advisor is a web-based tool that features interactive application wizards and a dynamic product selector. | Solution Advisor |
| Product Brief | The Product Brief contains concise overview/summary information to enable quick evaluation of a device for design suitability. | K20PB ¹ |
| Reference Manual | The Reference Manual contains a comprehensive description of the structure and function (operation) of a device. | K21P144M50SF5RM ¹ |
| Data Sheet | The Data Sheet includes electrical characteristics and signal connections. | K21P144M50SF5 ¹ |
| Package drawing | Package dimensions are provided in package drawings. | <ul style="list-style-type: none"> • LQFP 144-pin: 98ASS23177W¹ • MAPBGA 144-pin: 98ASA00222D¹ |

1. To find the associated resource, go to <http://www.freescale.com> and perform a search using this term.

Kinetic K21D Family

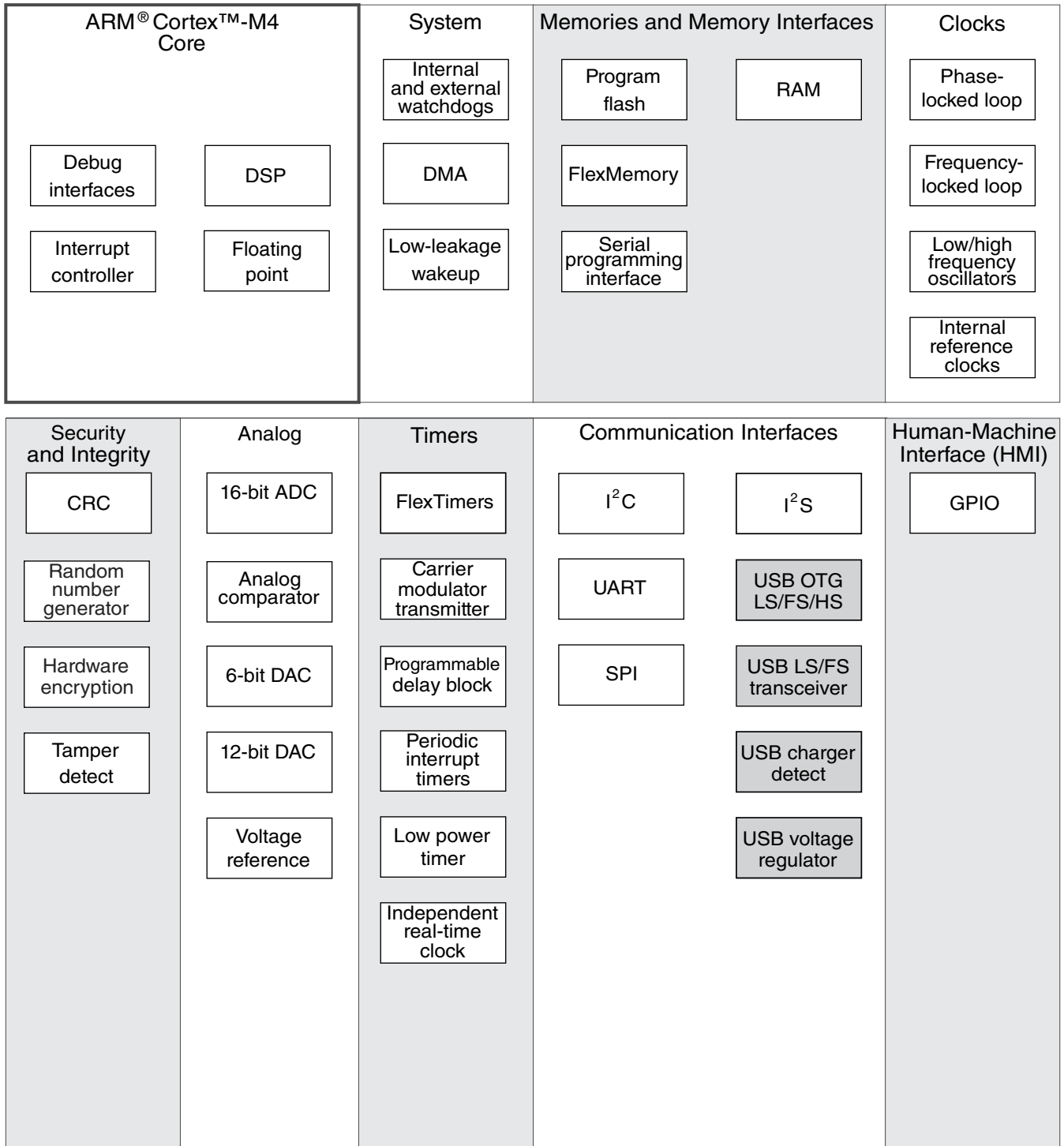

Figure 1. K20 block diagram



Table of Contents

| | | | |
|---|----|--|----|
| 1 Ratings..... | 5 | 3.4.1 Flash (FTFE) electrical specifications..... | 28 |
| 1.1 Thermal handling ratings..... | 5 | 3.4.2 EzPort switching specifications..... | 33 |
| 1.2 Moisture handling ratings..... | 5 | 3.4.3 Flexbus switching specifications..... | 34 |
| 1.3 ESD handling ratings..... | 5 | 3.5 Security and integrity modules..... | 37 |
| 1.4 Voltage and current operating ratings..... | 5 | 3.5.1 DryIce Tamper Electrical Specifications..... | 37 |
| 2 General..... | 6 | 3.6 Analog..... | 38 |
| 2.1 AC electrical characteristics..... | 6 | 3.6.1 ADC electrical specifications..... | 38 |
| 2.2 Nonswitching electrical specifications..... | 7 | 3.6.2 CMP and 6-bit DAC electrical specifications..... | 42 |
| 2.2.1 Voltage and current operating requirements..... | 7 | 3.6.3 12-bit DAC electrical characteristics..... | 44 |
| 2.2.2 LVD and POR operating requirements..... | 8 | 3.6.4 Voltage reference electrical specifications..... | 47 |
| 2.2.3 Voltage and current operating behaviors..... | 9 | 3.7 Timers..... | 48 |
| 2.2.4 Power mode transition operating behaviors..... | 10 | 3.8 Communication interfaces..... | 48 |
| 2.2.5 Power consumption operating behaviors..... | 11 | 3.8.1 USB electrical specifications..... | 48 |
| 2.2.6 EMC radiated emissions operating behaviors..... | 15 | 3.8.2 USB DCD electrical specifications..... | 49 |
| 2.2.7 Designing with radiated emissions in mind..... | 16 | 3.8.3 USB VREG electrical specifications..... | 49 |
| 2.2.8 Capacitance attributes..... | 16 | 3.8.4 CAN switching specifications..... | 50 |
| 2.3 Switching specifications..... | 16 | 3.8.5 DSPI switching specifications (limited voltage range)..... | 50 |
| 2.3.1 Device clock specifications..... | 16 | 3.8.6 DSPI switching specifications (full voltage range)..... | 52 |
| 2.3.2 General switching specifications..... | 17 | 3.8.7 I2C switching specifications..... | 53 |
| 2.4 Thermal specifications..... | 18 | 3.8.8 UART switching specifications..... | 54 |
| 2.4.1 Thermal operating requirements..... | 18 | 3.8.9 SDHC specifications..... | 54 |
| 2.4.2 Thermal attributes..... | 18 | 3.8.10 I2S switching specifications..... | 55 |
| 3 Peripheral operating requirements and behaviors..... | 20 | 4 Dimensions..... | 67 |
| 3.1 Core modules..... | 20 | 4.1 Obtaining package dimensions..... | 67 |
| 3.1.1 Debug trace timing specifications..... | 20 | 5 Pinout..... | 68 |
| 3.1.2 JTAG electricals..... | 20 | 5.1 K21 Signal Multiplexing and Pin Assignments..... | 68 |
| 3.2 System modules..... | 23 | 5.2 K21 Pinouts..... | 74 |
| 3.3 Clock modules..... | 23 | 6 Revision History..... | 76 |
| 3.3.1 MCG specifications..... | 23 | 7 Copyright..... | 0 |
| 3.3.2 Oscillator electrical specifications..... | 26 | 8 Legal..... | 0 |
| 3.3.3 32 kHz oscillator electrical characteristics..... | 28 | | |
| 3.4 Memories and memory interfaces..... | 28 | | |

1 Ratings

1.1 Thermal handling ratings

| Symbol | Description | Min. | Max. | Unit | Notes |
|------------------|-------------------------------|------|------|------|-------|
| T _{STG} | Storage temperature | -55 | 150 | °C | 1 |
| T _{SDR} | Solder temperature, lead-free | — | 260 | °C | 2 |

1. Determined according to JEDEC Standard JESD22-A103, *High Temperature Storage Life*.
2. Determined according to IPC/JEDEC Standard J-STD-020, *Moisture/Reflow Sensitivity Classification for Nonhermetic Solid State Surface Mount Devices*.

1.2 Moisture handling ratings

| Symbol | Description | Min. | Max. | Unit | Notes |
|--------|----------------------------|------|------|------|-------|
| MSL | Moisture sensitivity level | — | 3 | — | 1 |

1. Determined according to IPC/JEDEC Standard J-STD-020, *Moisture/Reflow Sensitivity Classification for Nonhermetic Solid State Surface Mount Devices*.

1.3 ESD handling ratings

| Symbol | Description | Min. | Max. | Unit | Notes |
|------------------|---|-------|-------|------|-------|
| V _{HBM} | Electrostatic discharge voltage, human body model | -2000 | +2000 | V | 1 |
| V _{CDM} | Electrostatic discharge voltage, charged-device model | -500 | +500 | V | 2 |
| I _{LAT} | Latch-up current at ambient temperature of 105°C | -100 | +100 | mA | 3 |

1. Determined according to JEDEC Standard JESD22-A114, *Electrostatic Discharge (ESD) Sensitivity Testing Human Body Model (HBM)*.
2. Determined according to JEDEC Standard JESD22-C101, *Field-Induced Charged-Device Model Test Method for Electrostatic-Discharge-Withstand Thresholds of Microelectronic Components*.
3. Determined according to JEDEC Standard JESD78, *IC Latch-Up Test*.

1.4 Voltage and current operating ratings

| Symbol | Description | Min. | Max. | Unit |
|----------------|--|----------------|----------------|------|
| V_{DD} | Digital supply voltage | -0.3 | 3.8 | V |
| I_{DD} | Digital supply current | — | 185 | mA |
| V_{DIO} | Digital input voltage (except RESET, EXTAL, and XTAL) | -0.3 | 5.5 | V |
| V_{AIO} | Analog ¹ , RESET, EXTAL, and XTAL input voltage | -0.3 | $V_{DD} + 0.3$ | V |
| I_D | Maximum current single pin limit (applies to all digital pins) | -25 | 25 | mA |
| V_{DDA} | Analog supply voltage | $V_{DD} - 0.3$ | $V_{DD} + 0.3$ | V |
| V_{USB0_DP} | USB0_DP input voltage | -0.3 | 3.63 | V |
| V_{USB0_DM} | USB0_DM input voltage | -0.3 | 3.63 | V |
| V_{BAT} | RTC battery supply voltage | -0.3 | 3.8 | V |

1. Analog pins are defined as pins that do not have an associated general purpose I/O port function.

2 General

2.1 AC electrical characteristics

Unless otherwise specified, propagation delays are measured from the 50% to the 50% point, and rise and fall times are measured at the 20% and 80% points, as shown in the following figure.

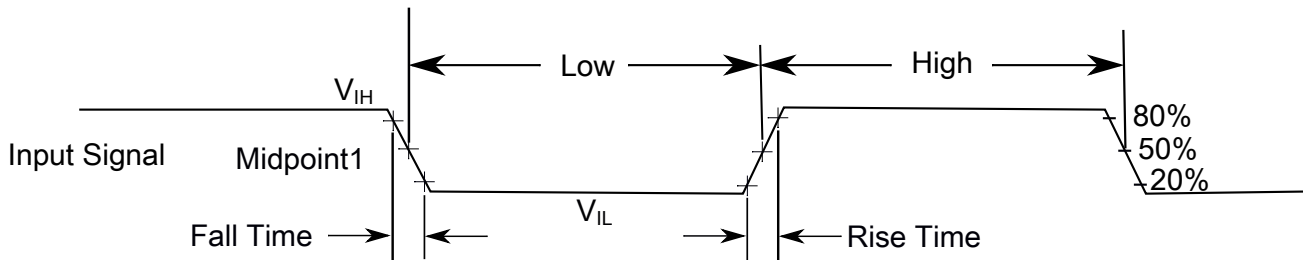

The midpoint is $V_{IL} + (V_{IH} - V_{IL}) / 2$

Figure 2. Input signal measurement reference

All digital I/O switching characteristics assume:

1. output pins
 - have $C_L=30\text{pF}$ loads,
 - are configured for fast slew rate ($\text{PORTx_PCRn}[\text{SRE}]=0$), and
 - are configured for high drive strength ($\text{PORTx_PCRn}[\text{DSE}]=1$)
2. input pins
 - have their passive filter disabled ($\text{PORTx_PCRn}[\text{PFE}]=0$)

2.2 Nonswitching electrical specifications

2.2.1 Voltage and current operating requirements

Table 1. Voltage and current operating requirements

| Symbol | Description | Min. | Max. | Unit | Notes |
|--------------------|--|---|---|--------|-------|
| V_{DD} | Supply voltage | 1.71 | 3.6 | V | |
| V_{DDA} | Analog supply voltage | 1.71 | 3.6 | V | |
| $V_{DD} - V_{DDA}$ | V_{DD} -to- V_{DDA} differential voltage | -0.1 | 0.1 | V | |
| $V_{SS} - V_{SSA}$ | V_{SS} -to- V_{SSA} differential voltage | -0.1 | 0.1 | V | |
| V_{BAT} | RTC battery supply voltage | 1.71 | 3.6 | V | |
| V_{IH} | Input high voltage <ul style="list-style-type: none"> $2.7\text{ V} \leq V_{DD} \leq 3.6\text{ V}$ $1.71\text{ V} \leq V_{DD} \leq 2.7\text{ V}$ | $0.7 \times V_{DD}$ $0.75 \times V_{DD}$ | — — | V V | |
| V_{IL} | Input low voltage <ul style="list-style-type: none"> $2.7\text{ V} \leq V_{DD} \leq 3.6\text{ V}$ $1.71\text{ V} \leq V_{DD} \leq 2.7\text{ V}$ | — — | $0.35 \times V_{DD}$ $0.3 \times V_{DD}$ | V V | |
| V_{HYS} | Input hysteresis | $0.06 \times V_{DD}$ | — | V | |
| I_{ICDIO} | Digital pin (except Tamper pins) negative DC injection current — single pin <ul style="list-style-type: none"> $V_{IN} < V_{SS}-0.3\text{V}$ | -5 | — | mA | 1 |
| I_{ICAI0} | Analog ² , EXTAL, and XTAL pin DC injection current — single pin <ul style="list-style-type: none"> $V_{IN} < V_{SS}-0.3\text{V}$ (Negative current injection) $V_{IN} > V_{DD}+0.3\text{V}$ (Positive current injection) | -5 — | — +5 | mA | 3 |
| I_{ICcont} | Contiguous pin DC injection current — regional limit, includes sum of negative injection currents or sum of positive injection currents of 16 contiguous pins <ul style="list-style-type: none"> Negative current injection Positive current injection | -25 — | — +25 | mA | |
| V_{ODPU} | Open drain pullup voltage level | V_{DD} | V_{DD} | V | 4 |
| V_{RAM} | V_{DD} voltage required to retain RAM | 1.2 | — | V | |
| V_{RFVBAT} | V_{BAT} voltage required to retain the VBAT register file | V_{POR_VBAT} | — | V | |

1. All 5 V tolerant digital I/O pins are internally clamped to V_{SS} through an ESD protection diode. There is no diode connection to V_{DD} . If V_{IN} is less than V_{DIO_MIN} , a current limiting resistor is required. If V_{IN} greater than V_{DIO_MIN} ($=V_{SS}-0.3\text{V}$) is observed, then there is no need to provide current limiting resistors at the pads. The negative DC injection current limiting resistor is calculated as $R=(V_{DIO_MIN}-V_{IN})/|I_{ICDIO}|$.

General

- Analog pins are defined as pins that do not have an associated general purpose I/O port function. Additionally, EXTAL and XTAL are analog pins.
- All analog pins are internally clamped to V_{SS} and V_{DD} through ESD protection diodes. If V_{IN} is less than V_{AIO_MIN} or greater than V_{AIO_MAX} , a current limiting resistor is required. The negative DC injection current limiting resistor is calculated as $R=(V_{AIO_MIN}-V_{IN})/|I_{CAIO}|$. The positive injection current limiting resistor is calculated as $R=(V_{IN}-V_{AIO_MAX})/|I_{CAIO}|$. Select the larger of these two calculated resistances if the pin is exposed to positive and negative injection currents.
- Open drain outputs must be pulled to V_{DD} .

2.2.2 LVD and POR operating requirements

Table 2. V_{DD} supply LVD and POR operating requirements

| Symbol | Description | Min. | Typ. | Max. | Unit | Notes |
|-------------|--|------|------|------|---------|-------|
| V_{POR} | Falling VDD POR detect voltage | 0.8 | 1.1 | 1.5 | V | |
| V_{LVDH} | Falling low-voltage detect threshold — high range (LVDV=01) | 2.48 | 2.56 | 2.64 | V | |
| V_{LVW1H} | Low-voltage warning thresholds — high range <ul style="list-style-type: none"> Level 1 falling (LVWV=00) Level 2 falling (LVWV=01) Level 3 falling (LVWV=10) Level 4 falling (LVWV=11) | 2.62 | 2.70 | 2.78 | V | 1 |
| V_{LVW2H} | | 2.72 | 2.80 | 2.88 | V | |
| V_{LVW3H} | | 2.82 | 2.90 | 2.98 | V | |
| V_{LVW4H} | | 2.92 | 3.00 | 3.08 | V | |
| V_{HYSH} | Low-voltage inhibit reset/recover hysteresis — high range | — | 80 | — | mV | |
| V_{LVDL} | Falling low-voltage detect threshold — low range (LVDV=00) | 1.54 | 1.60 | 1.66 | V | |
| V_{LVW1L} | Low-voltage warning thresholds — low range <ul style="list-style-type: none"> Level 1 falling (LVWV=00) Level 2 falling (LVWV=01) Level 3 falling (LVWV=10) Level 4 falling (LVWV=11) | 1.74 | 1.80 | 1.86 | V | 1 |
| V_{LVW2L} | | 1.84 | 1.90 | 1.96 | V | |
| V_{LVW3L} | | 1.94 | 2.00 | 2.06 | V | |
| V_{LVW4L} | | 2.04 | 2.10 | 2.16 | V | |
| V_{HYSL} | Low-voltage inhibit reset/recover hysteresis — low range | — | 60 | — | mV | |
| V_{BG} | Bandgap voltage reference | 0.97 | 1.00 | 1.03 | V | |
| t_{LPO} | Internal low power oscillator period — factory trimmed | 900 | 1000 | 1100 | μ s | |

- Rising threshold is the sum of falling threshold and hysteresis voltage

Table 3. VBAT power operating requirements

| Symbol | Description | Min. | Typ. | Max. | Unit | Notes |
|-----------------|--|------|------|------|------|-------|
| V_{POR_VBAT} | Falling VBAT supply POR detect voltage | 0.8 | 1.1 | 1.5 | V | |

2.2.3 Voltage and current operating behaviors

Table 4. Voltage and current operating behaviors

| Symbol | Description | Min. | Typ | Max. | Unit | Notes | |
|---|---|---|------------------------|------|------|-------|--|
| V _{OH} | Output high voltage — high drive strength | | | | | | |
| | • 2.7 V ≤ V _{DD} ≤ 3.6 V, I _{OH} = -8mA | V _{DD} - 0.5 | — | — | V | | |
| | • 1.71 V ≤ V _{DD} ≤ 2.7 V, I _{OH} = -3mA | V _{DD} - 0.5 | — | — | V | | |
| | Output high voltage — low drive strength | | | | | | |
| I _{OHT} | Output high current total for all ports | — | — | 100 | mA | | |
| | V _{OH_Tamper} | Output high voltage — high drive strength | V _{BAT} - 0.5 | | | V | |
| | | • 2.7 V ≤ V _{BAT} ≤ 3.6 V, I _{OH} = -10mA | V _{BAT} - 0.5 | — | — | V | |
| | • 1.71 V ≤ V _{BAT} ≤ 2.7 V, I _{OH} = -3mA | | — | — | | | |
| Output high voltage — low drive strength | V _{BAT} - 0.5 | | | V | | | |
| • 2.7 V ≤ V _{BAT} ≤ 3.6 V, I _{OH} = -2mA | V _{BAT} - 0.5 | — | — | V | | | |
| • 1.71 V ≤ V _{BAT} ≤ 2.7 V, I _{OH} = -0.6mA | | — | — | | | | |
| I _{OH_Tamper} | Output high current total for Tamper pins | — | — | 100 | mA | | |
| V _{OL} | Output low voltage — high drive strength | | | | | 1 | |
| | • 2.7 V ≤ V _{DD} ≤ 3.6 V, I _{OL} = 9mA | — | — | 0.5 | V | | |
| | • 1.71 V ≤ V _{DD} ≤ 2.7 V, I _{OL} = 3mA | — | — | 0.5 | V | | |
| | Output low voltage — low drive strength | | | | | | |
| I _{OLT} | Output low current total for all ports | — | — | 100 | mA | | |
| | V _{OL_Tamper} | Output low voltage — high drive strength | | | 0.5 | V | |
| | | • 2.7 V ≤ V _{BAT} ≤ 3.6 V, I _{OL} = 10mA | — | — | 0.5 | V | |
| | • 1.71 V ≤ V _{BAT} ≤ 2.7 V, I _{OL} = 3mA | — | — | | | | |
| Output low voltage — low drive strength | | | 0.5 | V | | | |
| • 2.7 V ≤ V _{BAT} ≤ 3.6 V, I _{OL} = 2mA | — | — | 0.5 | V | | | |
| • 1.71 V ≤ V _{BAT} ≤ 2.7 V, I _{OL} = 0.6mA | — | — | | | | | |
| I _{OL_Tamper} | Output low current total for Tamper pins | — | — | 100 | mA | | |
| I _{IND} | Input leakage current, digital pins | | | | | 2, 3 | |
| | • V _{SS} ≤ V _{IN} ≤ V _{IL} | | | | | | |
| | • All digital pins | — | 0.002 | 0.5 | μA | | |

Table continues on the next page...

Table 4. Voltage and current operating behaviors (continued)

| Symbol | Description | Min. | Typ | Max. | Unit | Notes |
|------------------|---|------|-------|-------|------------------|-------|
| | <ul style="list-style-type: none"> $V_{IN} = V_{DD}$ All digital pins except PTD7 PTD7 | — | 0.002 | 0.5 | μA | |
| | | — | 0.004 | 1 | μA | |
| I_{IND} | Input leakage current, digital pins <ul style="list-style-type: none"> $V_{IL} < V_{IN} < V_{DD}$ $V_{DD} = 3.6\text{ V}$ $V_{DD} = 3.0\text{ V}$ $V_{DD} = 2.5\text{ V}$ $V_{DD} = 1.7\text{ V}$ | — | 18 | 26 | μA | 2 |
| | | — | 12 | 19 | μA | |
| | | — | 8 | 13 | μA | |
| | | — | 3 | 6 | μA | |
| I_{IND} | Input leakage current, digital pins <ul style="list-style-type: none"> $V_{DD} < V_{IN} < 5.5\text{ V}$ | — | 1 | 50 | μA | |
| I_{IN_Tamper} | Input leakage current (per Tamper pin) for full temperature range | — | — | 1 | μA | |
| I_{IN_Tamper} | Input leakage current (per Tamper pin) at 25°C | — | — | 0.025 | μA | |
| I_{OZ} | Hi-Z (off-state) leakage current (per pin) | — | — | 0.25 | μA | |
| I_{OZ_Tamper} | Hi-Z (off-state) leakage current (per Tamper pin) | — | — | 0.25 | μA | |
| R_{PU} | Internal pullup resistors (except Tamper pins) | 20 | 35 | 50 | $\text{k}\Omega$ | 4 |
| R_{PD} | Internal pulldown resistors (except Tamper pins) | 20 | 35 | 50 | $\text{k}\Omega$ | 5 |

1. Open drain outputs must be pulled to V_{DD} .
2. Measured at $V_{DD}=3.6\text{V}$
3. Internal pull-up/pull-down resistors disabled.
4. Measured at V_{DD} supply voltage = V_{DD} min and $V_{input} = V_{SS}$
5. Measured at V_{DD} supply voltage = V_{DD} min and $V_{input} = V_{DD}$

2.2.4 Power mode transition operating behaviors

All specifications except t_{POR} , and $V_{LLSx} \rightarrow \text{RUN}$ recovery times in the following table assume this clock configuration:

- CPU and system clocks = 100 MHz
- Bus clock = 50 MHz
- FlexBus clock = 50 MHz
- Flash clock = 25 MHz

Table 5. Power mode transition operating behaviors

| Symbol | Description | Min. | Max. | Unit | Notes |
|------------------|---|------|------|------|-------|
| t _{POR} | After a POR event, amount of time from the point V _{DD} reaches 1.71 V to execution of the first instruction across the operating temperature range of the chip. | — | 300 | μs | |
| | • VLLS0 → RUN | — | 183 | μs | |
| | • VLLS1 → RUN | — | 183 | μs | |
| | • VLLS2 → RUN | — | 105 | μs | |
| | • VLLS3 → RUN | — | 105 | μs | |
| | • LLS → RUN | — | 5.0 | μs | |
| | • VLPS → RUN | — | 4.4 | μs | |
| | • STOP → RUN | — | 4.4 | μs | |

2.2.5 Power consumption operating behaviors

Table 6. Power consumption operating behaviors

| Symbol | Description | Min. | Typ. | Max. | Unit | Notes |
|----------------------|---|------|-------|----------|------|-------|
| I _{DDA} | Analog supply current | — | — | See note | mA | 1 |
| I _{DD_RUN} | Run mode current — all peripheral clocks disabled, code executing from flash | | | | | 2 |
| | • @ 1.8V | — | 33.57 | 36.2 | mA | |
| | • @ 3.0V | — | 33.51 | 36.1 | mA | |
| I _{DD_RUN} | Run mode current — all peripheral clocks enabled, code executing from flash | | | | | 3, 4 |
| | • @ 1.8V | — | 46.36 | 50.1 | mA | |
| | • @ 3.0V | | | | | |
| | • @ 25°C | — | 46.31 | 49.9 | mA | |
| | • @ 125°C | — | 57.4 | — | mA | |
| I _{DD_WAIT} | Wait mode high frequency current at 3.0 V — all peripheral clocks disabled | — | 18.2 | — | mA | 2 |
| I _{DD_WAIT} | Wait mode reduced frequency current at 3.0 V — all peripheral clocks disabled | — | 7.2 | — | mA | 5 |

Table continues on the next page...

Table 6. Power consumption operating behaviors (continued)

| Symbol | Description | Min. | Typ. | Max. | Unit | Notes |
|-----------------------|--|------|-------|------|------|-------|
| I _{DD_VLPR} | Very-low-power run mode current at 3.0 V — all peripheral clocks disabled | — | 1.21 | — | mA | 6 |
| I _{DD_VLPR} | Very-low-power run mode current at 3.0 V — all peripheral clocks enabled | — | 1.88 | — | mA | 7 |
| I _{DD_VLPW} | Very-low-power wait mode current at 3.0 V — all peripheral clocks disabled | — | 0.80 | — | mA | 8 |
| I _{DD_STOP} | Stop mode current at 3.0 V <ul style="list-style-type: none"> • @ -40 to 25°C • @ 70°C • @ 105°C | — | 0.528 | 2.25 | mA | |
| I _{DD_VLPS} | Very-low-power stop mode current at 3.0 V <ul style="list-style-type: none"> • @ -40 to 25°C • @ 70°C • @ 105°C | — | 78 | 700 | μA | |
| I _{DD_LLS} | Low leakage stop mode current at 3.0 V <ul style="list-style-type: none"> • @ -40 to 25°C • @ 70°C • @ 105°C | — | 5.1 | 15 | μA | |
| I _{DD_VLLS3} | Very low-leakage stop mode 3 current at 3.0 V <ul style="list-style-type: none"> • @ -40 to 25°C • @ 70°C • @ 105°C | — | 3.1 | 7.5 | μA | |
| I _{DD_VLLS2} | Very low-leakage stop mode 2 current at 3.0 V <ul style="list-style-type: none"> • @ -40 to 25°C • @ 70°C • @ 105°C | — | 2.0 | 5 | μA | |
| I _{DD_VLLS1} | Very low-leakage stop mode 1 current at 3.0 V <ul style="list-style-type: none"> • @ -40 to 25°C • @ 70°C • @ 105°C | — | 1.25 | 2.1 | μA | |
| I _{DD_VLLS0} | Very low-leakage stop mode 0 current at 3.0 V with POR detect circuit enabled <ul style="list-style-type: none"> • @ -40 to 25°C • @ 70°C • @ 105°C | — | 0.745 | 1.65 | μA | |

Table continues on the next page...

Table 6. Power consumption operating behaviors (continued)

| Symbol | Description | Min. | Typ. | Max. | Unit | Notes |
|-----------------------|--|------|-------|------|------|-------|
| I _{DD_VLLS0} | Very low-leakage stop mode 0 current at 3.0 V with POR detect circuit disabled <ul style="list-style-type: none"> • @ -40 to 25°C • @ 70°C • @ 105°C | — | 0.268 | 1.25 | μA | |
| | | — | 3.7 | 15 | μA | |
| | | — | 22.9 | 95 | μA | |
| I _{DD_VBAT} | Average current with RTC and 32kHz disabled at 3.0 V <ul style="list-style-type: none"> • @ -40 to 25°C • @ 70°C • @ 105°C | — | 0.19 | 0.22 | μA | |
| | | — | 0.49 | 0.64 | μA | |
| | | — | 2.2 | 3.2 | μA | |
| I _{DD_VBAT} | Average current when CPU is not accessing RTC registers <ul style="list-style-type: none"> • @ 1.8V <ul style="list-style-type: none"> • @ -40 to 25°C • @ 70°C • @ 105°C • @ 3.0V <ul style="list-style-type: none"> • @ -40 to 25°C • @ 70°C • @ 105°C | — | 0.68 | 0.8 | μA | 9 |
| | | — | 1.2 | 1.56 | μA | |
| | | — | 3.6 | 5.3 | μA | |
| | | — | 0.81 | 0.96 | μA | |
| | | — | 1.45 | 1.89 | μA | |
| | | — | 4.3 | 6.33 | μA | |
| | | — | 4.3 | 6.33 | μA | |

1. The analog supply current is the sum of the active or disabled current for each of the analog modules on the device. See each module's specification for its supply current.
2. 120 MHz core and system clock, 60 MHz bus and FlexBus clock, and 24 MHz flash clock. MCG configured for PEE mode. All peripheral clocks disabled.
3. 120 MHz core and system clock, 60 MHz bus and FlexBus clock, and 24 MHz flash clock. MCG configured for PEE mode. All peripheral clocks enabled.
4. Max values are measured with CPU executing DSP instructions.
5. 25 MHz core and system clock, 25 MHz bus clock, and 12.5 MHz FlexBus and flash clock. MCG configured for FEI mode.
6. 4 MHz core, system, FlexBus, and bus clock and 1 MHz flash clock. MCG configured for BLPE mode. All peripheral clocks disabled. Code executing from flash.
7. 4 MHz core, system, FlexBus, and bus clock and 1 MHz flash clock. MCG configured for BLPE mode. All peripheral clocks enabled but peripherals are not in active operation. Code executing from flash.
8. 4 MHz core, system, FlexBus, and bus clock and 1 MHz flash clock. MCG configured for BLPE mode. All peripheral clocks disabled.
9. Includes 32kHz oscillator current and RTC operation.

2.2.5.1 Diagram: Typical I_{DD_RUN} operating behavior

The following data was measured under these conditions:

- MCG in PEE mode at greater than 100 MHz frequencies

- No GPIOs toggled
- Code execution from flash with cache enabled
- For the ALLOFF curve, all peripheral clocks are disabled except FTFE

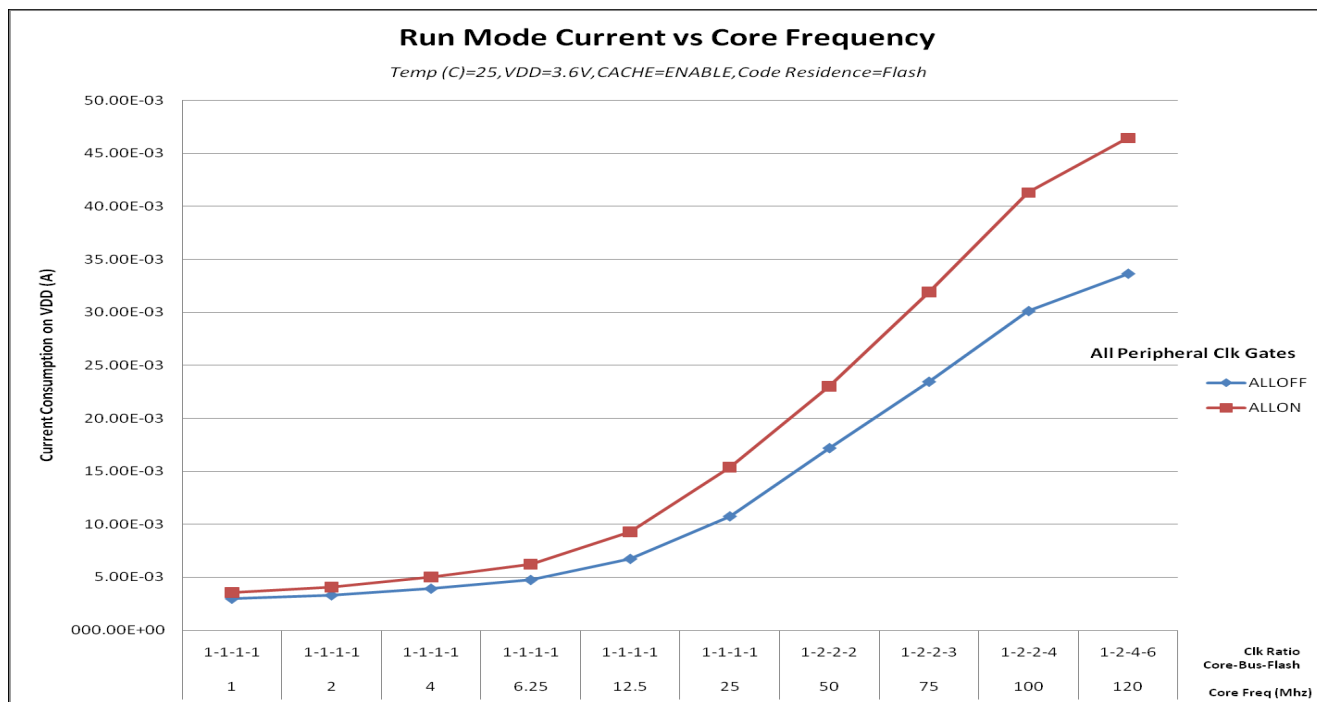

Figure 3. Run mode supply current vs. core frequency

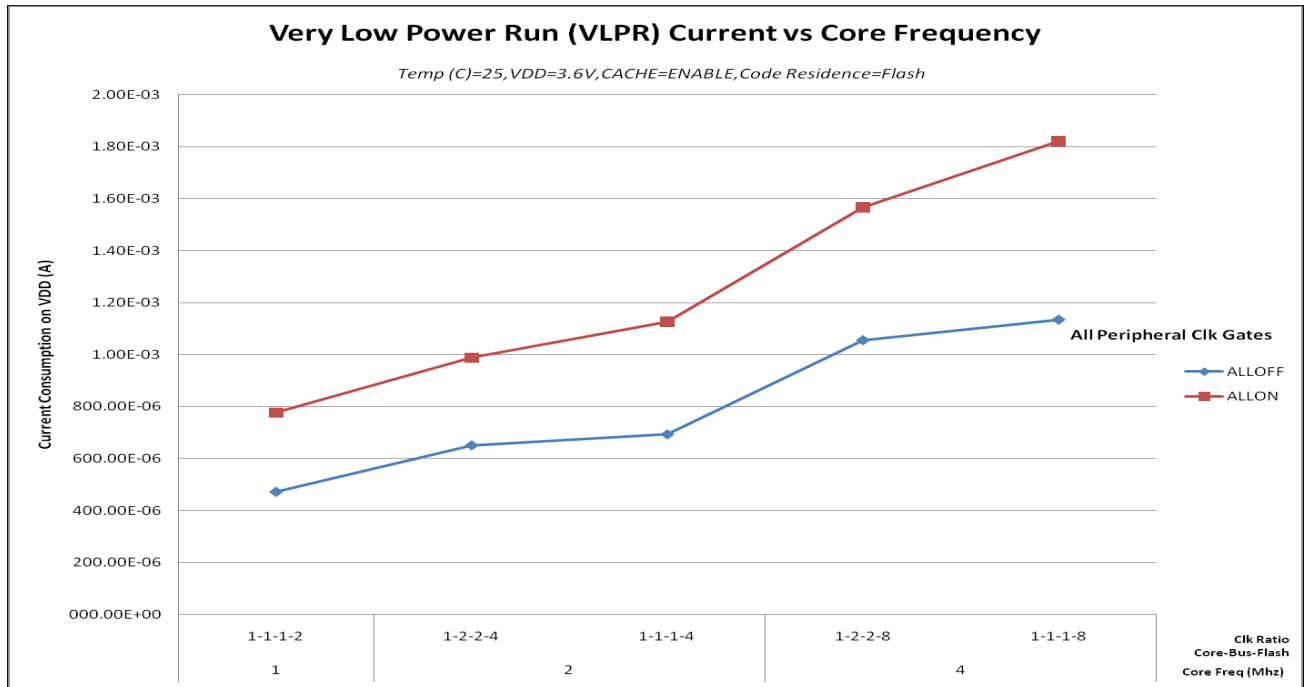

Figure 4. VLPR mode supply current vs. core frequency

2.2.6 EMC radiated emissions operating behaviors

Table 7. EMC radiated emissions operating behaviors

| Symbol | Description | Frequency band (MHz) | Typ. | Unit | Notes |
|---------------------|------------------------------------|----------------------|------|------|-------|
| V _{RE1} | Radiated emissions voltage, band 1 | 0.15–50 | 23 | dBμV | 1, 2 |
| V _{RE2} | Radiated emissions voltage, band 2 | 50–150 | 27 | dBμV | |
| V _{RE3} | Radiated emissions voltage, band 3 | 150–500 | 28 | dBμV | |
| V _{RE4} | Radiated emissions voltage, band 4 | 500–1000 | 14 | dBμV | |
| V _{RE_IEC} | IEC level | 0.15–1000 | K | — | 2, 3 |

1. Determined according to IEC Standard 61967-1, *Integrated Circuits - Measurement of Electromagnetic Emissions, 150 kHz to 1 GHz Part 1: General Conditions and Definitions* and IEC Standard 61967-2, *Integrated Circuits - Measurement of Electromagnetic Emissions, 150 kHz to 1 GHz Part 2: Measurement of Radiated Emissions—TEM Cell and Wideband TEM Cell Method*. Measurements were made while the microcontroller was running basic

General

application code. The reported emission level is the value of the maximum measured emission, rounded up to the next whole number, from among the measured orientations in each frequency range.

2. $V_{DD} = 3.3\text{ V}$, $T_A = 25\text{ }^\circ\text{C}$, $f_{OSC} = 12\text{ MHz}$ (crystal), $f_{SYS} = 96\text{ MHz}$, $f_{BUS} = 48\text{ MHz}$
3. Specified according to Annex D of IEC Standard 61967-2, *Measurement of Radiated Emissions—TEM Cell and Wideband TEM Cell Method*

2.2.7 Designing with radiated emissions in mind

To find application notes that provide guidance on designing your system to minimize interference from radiated emissions:

1. Go to www.freescale.com.
2. Perform a keyword search for “EMC design.”

2.2.8 Capacitance attributes

Table 8. Capacitance attributes

| Symbol | Description | Min. | Max. | Unit |
|-------------|---------------------------------|------|------|------|
| C_{IN_A} | Input capacitance: analog pins | — | 7 | pF |
| C_{IN_D} | Input capacitance: digital pins | — | 7 | pF |

2.3 Switching specifications

2.3.1 Device clock specifications

Table 9. Device clock specifications

| Symbol | Description | Min. | Max. | Unit | Notes |
|------------------------|--|------|------|------|-------|
| Normal run mode | | | | | |
| f_{SYS} | System and core clock | — | 120 | MHz | |
| f_{SYS_USB} | System and core clock when Full Speed USB in operation | 20 | — | MHz | |
| f_{BUS} | Bus clock | — | 60 | MHz | |
| FB_CLK | FlexBus clock | — | 50 | MHz | |
| f_{FLASH} | Flash clock | — | 25 | MHz | |
| f_{LPTMR} | LPTMR clock | — | 25 | MHz | |
| VLPR mode ¹ | | | | | |
| f_{SYS} | System and core clock | — | 4 | MHz | |
| f_{BUS} | Bus clock | — | 4 | MHz | |

Table continues on the next page...

Table 9. Device clock specifications (continued)

| Symbol | Description | Min. | Max. | Unit | Notes |
|----------------------------|----------------------------------|------|------|------|-------|
| FB_CLK | FlexBus clock | — | 4 | MHz | |
| f _{FLASH} | Flash clock | — | 0.8 | MHz | |
| f _{ERCLK} | External reference clock | — | 16 | MHz | |
| f _{LPTMR_pin} | LPTMR clock | — | 25 | MHz | |
| f _{LPTMR_ERCLK} | LPTMR external reference clock | — | 16 | MHz | |
| f _{FlexCAN_ERCLK} | FlexCAN external reference clock | — | 8 | MHz | |
| f _{I2S_MCLK} | I2S master clock | — | 12.5 | MHz | |
| f _{I2S_BCLK} | I2S bit clock | — | 4 | MHz | |

1. The frequency limitations in VLPR mode here override any frequency specification listed in the timing specification for any other module.

2.3.2 General switching specifications

These general purpose specifications apply to all pins configured for:

- GPIO signaling
- Other peripheral module signaling not explicitly stated elsewhere

Table 10. General switching specifications

| Symbol | Description | Min. | Max. | Unit | Notes |
|--------|---|------|------|------------------|-------|
| | GPIO pin interrupt pulse width (digital glitch filter disabled) — Synchronous path | 1.5 | — | Bus clock cycles | 1, 2 |
| | GPIO pin interrupt pulse width (digital glitch filter disabled, analog filter enabled) — Asynchronous path | 100 | — | ns | 3 |
| | GPIO pin interrupt pulse width (digital glitch filter disabled, analog filter disabled) — Asynchronous path | 16 | — | ns | 3 |
| | External reset pulse width (digital glitch filter disabled) | 100 | — | ns | 3 |
| | Mode select ($\overline{\text{EZP_CS}}$) hold time after reset deassertion | 2 | — | Bus clock cycles | |
| | Port rise and fall time (high drive strength) | | | | 4 |
| | <ul style="list-style-type: none"> • Slew disabled <ul style="list-style-type: none"> • $1.71 \leq V_{DD} \leq 2.7V$ • $2.7 \leq V_{DD} \leq 3.6V$ • Slew enabled <ul style="list-style-type: none"> • $1.71 \leq V_{DD} \leq 2.7V$ • $2.7 \leq V_{DD} \leq 3.6V$ | — | 12 | ns | |
| | | — | 6 | ns | |
| | | — | 36 | ns | |
| | | — | 24 | ns | |

Table continues on the next page...

Table 10. General switching specifications (continued)

| Symbol | Description | Min. | Max. | Unit | Notes |
|--------|---|------|------|------|-------|
| | Port rise and fall time (low drive strength) | | | | 5 |
| | <ul style="list-style-type: none"> • Slew disabled <ul style="list-style-type: none"> • $1.71 \leq V_{DD} \leq 2.7V$ • $2.7 \leq V_{DD} \leq 3.6V$ • Slew enabled <ul style="list-style-type: none"> • $1.71 \leq V_{DD} \leq 2.7V$ • $2.7 \leq V_{DD} \leq 3.6V$ | — | 12 | ns | |
| | | — | 6 | ns | |
| | | — | 36 | ns | |
| | | — | 24 | ns | |

1. This is the minimum pulse width that is guaranteed to pass through the pin synchronization circuitry. Shorter pulses may or may not be recognized. In Stop, VLPS, LLS, and VLLSx modes, the synchronizer is bypassed so shorter pulses can be recognized in that case.
2. The greater synchronous and asynchronous timing must be met.
3. This is the minimum pulse width that is guaranteed to be recognized as a pin interrupt request in Stop, VLPS, LLS, and VLLSx modes.
4. 75 pF load
5. 15 pF load

2.4 Thermal specifications

2.4.1 Thermal operating requirements

Table 11. Thermal operating requirements

| Symbol | Description | Min. | Max. | Unit |
|--------|--------------------------|------|------|------|
| T_J | Die junction temperature | -40 | 125 | °C |
| T_A | Ambient temperature | -40 | 105 | °C |

2.4.2 Thermal attributes

| Board type | Symbol | Description | 144 LQFP | 144 MAPBGA | Unit | Notes |
|-------------------|-----------------|--|----------|------------|------|-------|
| Single-layer (1s) | $R_{\theta JA}$ | Thermal resistance, junction to ambient (natural convection) | 45 | 48 | °C/W | 1 |
| Four-layer (2s2p) | $R_{\theta JA}$ | Thermal resistance, | 36 | 29 | °C/W | 1 |

Table continues on the next page...

| Board type | Symbol | Description | 144 LQFP | 144 MAPBGA | Unit | Notes |
|-------------------|------------------|---|----------|------------|------|-------|
| | | junction to ambient (natural convection) | | | | |
| Single-layer (1s) | $R_{\theta JMA}$ | Thermal resistance, junction to ambient (200 ft./min. air speed) | 36 | 38 | °C/W | 1 |
| Four-layer (2s2p) | $R_{\theta JMA}$ | Thermal resistance, junction to ambient (200 ft./min. air speed) | 30 | 25 | °C/W | 1 |
| — | $R_{\theta JB}$ | Thermal resistance, junction to board | 24 | 16 | °C/W | 2 |
| — | $R_{\theta JC}$ | Thermal resistance, junction to case | 9 | 9 | °C/W | 3 |
| — | Ψ_{JT} | Thermal characterization parameter, junction to package top outside center (natural convection) | 2 | 2 | °C/W | 4 |

Notes

1. Determined according to JEDEC Standard JESD51-2, *Integrated Circuits Thermal Test Method Environmental Conditions—Natural Convection (Still Air)*, or EIA/JEDEC Standard JESD51-6, *Integrated Circuit Thermal Test Method Environmental Conditions—Forced Convection (Moving Air)*.
2. Determined according to JEDEC Standard JESD51-8, *Integrated Circuit Thermal Test Method Environmental Conditions—Junction-to-Board*.
3. Determined according to Method 1012.1 of MIL-STD 883, *Test Method Standard, Microcircuits*, with the cold plate temperature used for the case temperature. The value includes the thermal resistance of the interface material between the top of the package and the cold plate.
4. Determined according to JEDEC Standard JESD51-2, *Integrated Circuits Thermal Test Method Environmental Conditions—Natural Convection (Still Air)*.

3 Peripheral operating requirements and behaviors

3.1 Core modules

3.1.1 Debug trace timing specifications

Table 12. Debug trace operating behaviors

| Symbol | Description | Min. | Max. | Unit |
|-----------|--------------------------|---|------|------|
| T_{cyc} | Clock period | Frequency dependent (limited to 50 MHz) | | MHz |
| T_{wl} | Low pulse width | 2 | — | ns |
| T_{wh} | High pulse width | 2 | — | ns |
| T_r | Clock and data rise time | — | 3 | ns |
| T_f | Clock and data fall time | — | 3 | ns |
| T_s | Data setup | 3 | — | ns |
| T_h | Data hold | 2 | — | ns |

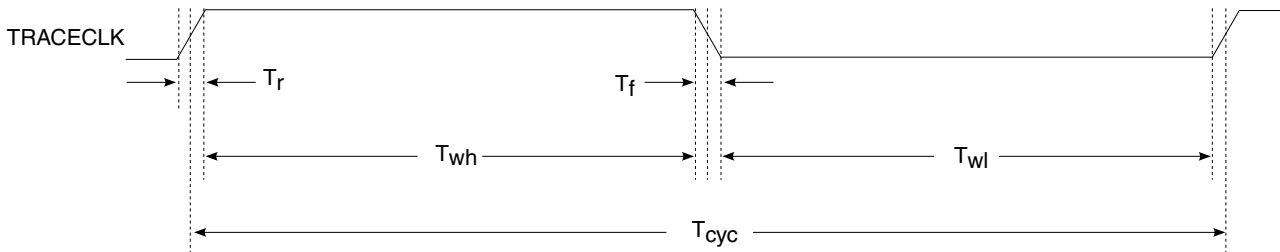

Figure 5. TRACE_CLKOUT specifications

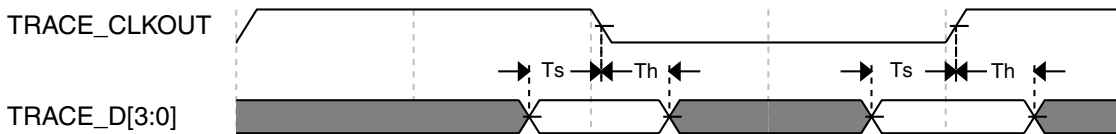

Figure 6. Trace data specifications

3.1.2 JTAG electricals

Table 13. JTAG limited voltage range electricals

| Symbol | Description | Min. | Max. | Unit |
|--------|--|----------------|----------------|----------------|
| | Operating voltage | 2.7 | 3.6 | V |
| J1 | TCLK frequency of operation <ul style="list-style-type: none"> • Boundary Scan • JTAG and CJTAG • Serial Wire Debug | 0 0 0 | 10 25 50 | MHz |
| J2 | TCLK cycle period | 1/J1 | — | ns |
| J3 | TCLK clock pulse width <ul style="list-style-type: none"> • Boundary Scan • JTAG and CJTAG • Serial Wire Debug | 50 20 10 | — — — | ns ns ns |
| J4 | TCLK rise and fall times | — | 3 | ns |
| J5 | Boundary scan input data setup time to TCLK rise | 20 | — | ns |
| J6 | Boundary scan input data hold time after TCLK rise | 2.6 | — | ns |
| J7 | TCLK low to boundary scan output data valid | — | 25 | ns |
| J8 | TCLK low to boundary scan output high-Z | — | 25 | ns |
| J9 | TMS, TDI input data setup time to TCLK rise | 8 | — | ns |
| J10 | TMS, TDI input data hold time after TCLK rise | 1 | — | ns |
| J11 | TCLK low to TDO data valid | — | 17 | ns |
| J12 | TCLK low to TDO high-Z | — | 17 | ns |
| J13 | $\overline{\text{TRST}}$ assert time | 100 | — | ns |
| J14 | $\overline{\text{TRST}}$ setup time (negation) to TCLK high | 8 | — | ns |

Table 14. JTAG full voltage range electricals

| Symbol | Description | Min. | Max. | Unit |
|--------|--|------------------|----------------|----------------|
| | Operating voltage | 1.71 | 3.6 | V |
| J1 | TCLK frequency of operation <ul style="list-style-type: none"> • Boundary Scan • JTAG and CJTAG • Serial Wire Debug | 0 0 0 | 10 20 40 | MHz |
| J2 | TCLK cycle period | 1/J1 | — | ns |
| J3 | TCLK clock pulse width <ul style="list-style-type: none"> • Boundary Scan • JTAG and CJTAG • Serial Wire Debug | 50 25 12.5 | — — — | ns ns ns |

Table continues on the next page...

Table 14. JTAG full voltage range electricals (continued)

| Symbol | Description | Min. | Max. | Unit |
|--------|---|------|------|------|
| J4 | TCLK rise and fall times | — | 3 | ns |
| J5 | Boundary scan input data setup time to TCLK rise | 20 | — | ns |
| J6 | Boundary scan input data hold time after TCLK rise | 0 | — | ns |
| J7 | TCLK low to boundary scan output data valid | — | 25 | ns |
| J8 | TCLK low to boundary scan output high-Z | — | 25 | ns |
| J9 | TMS, TDI input data setup time to TCLK rise | 8 | — | ns |
| J10 | TMS, TDI input data hold time after TCLK rise | 1.4 | — | ns |
| J11 | TCLK low to TDO data valid | — | 22.1 | ns |
| J12 | TCLK low to TDO high-Z | — | 22.1 | ns |
| J13 | $\overline{\text{TRST}}$ assert time | 100 | — | ns |
| J14 | $\overline{\text{TRST}}$ setup time (negation) to TCLK high | 8 | — | ns |

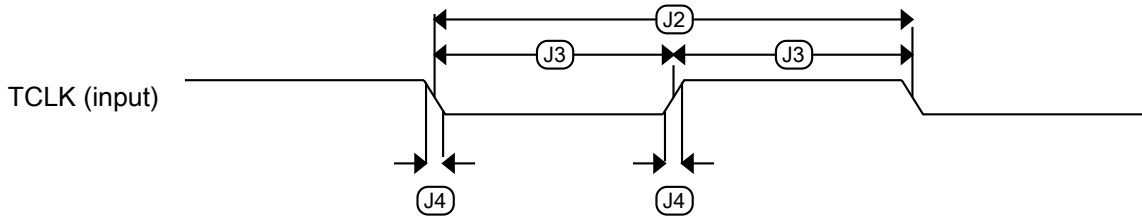

Figure 7. Test clock input timing

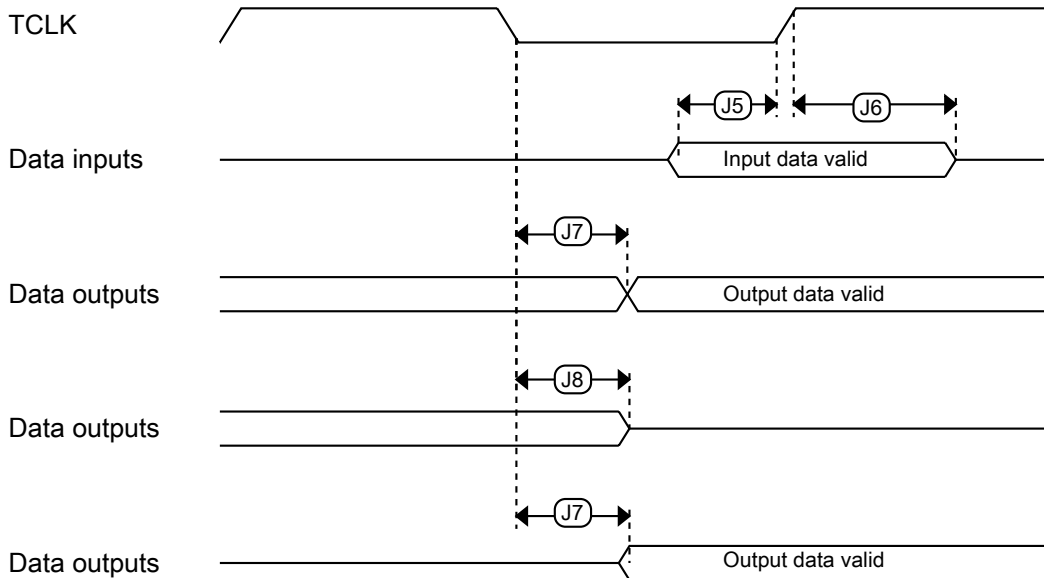

Figure 8. Boundary scan (JTAG) timing

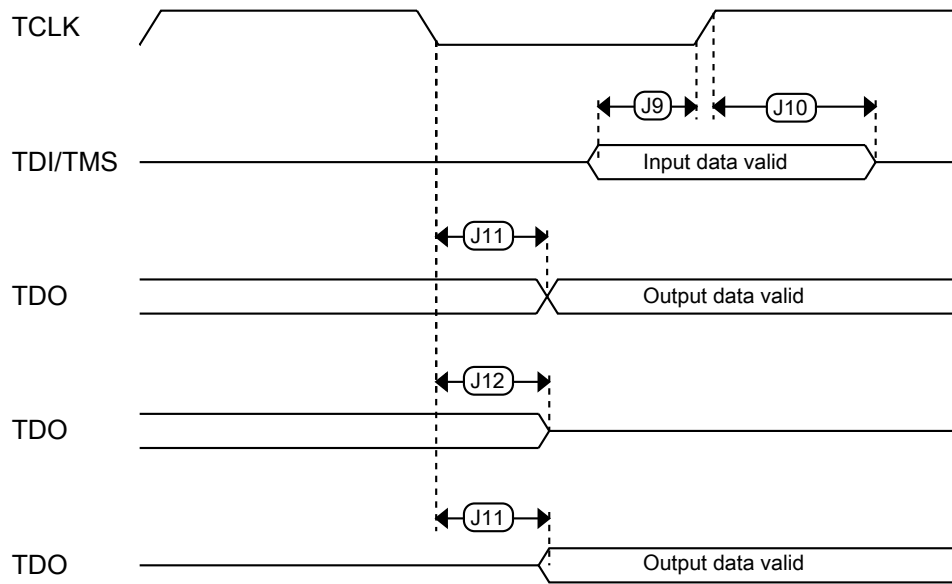

Figure 9. Test Access Port timing

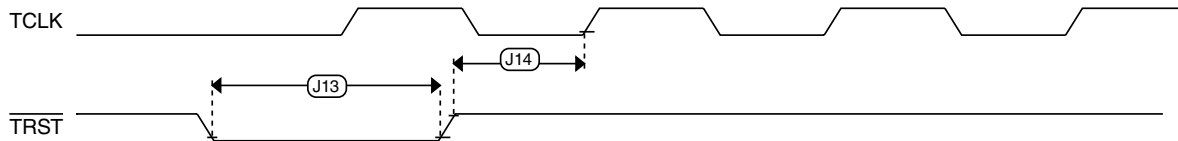

Figure 10. $\overline{\text{TRST}}$ timing

3.2 System modules

There are no specifications necessary for the device's system modules.

3.3 Clock modules

3.3.1 MCG specifications

Table 15. MCG specifications

| Symbol | Description | Min. | Typ. | Max. | Unit | Notes | |
|--------------------------|--|--|--------|---------|-------------|-------|------|
| f_{ints_ft} | Internal reference frequency (slow clock) — factory trimmed at nominal VDD and 25 °C | — | 32.768 | — | kHz | | |
| f_{ints_t} | Internal reference frequency (slow clock) — user trimmed | 31.25 | — | 39.0625 | kHz | | |
| I_{ints} | Internal reference (slow clock) current | — | 20 | — | μA | | |
| $\Delta f_{dco_res_t}$ | Resolution of trimmed average DCO output frequency at fixed voltage and temperature — using SCTRIM and SCFTRIM | — | ± 0.3 | ± 0.6 | % f_{dco} | 1 | |
| $\Delta f_{dco_res_t}$ | Resolution of trimmed average DCO output frequency at fixed voltage and temperature — using SCTRIM only | — | ± 0.2 | ± 0.5 | % f_{dco} | 1 | |
| Δf_{dco_t} | Total deviation of trimmed average DCO output frequency over voltage and temperature | — | ± 0.5 | ± 2 | % f_{dco} | 1, 2 | |
| Δf_{dco_t} | Total deviation of trimmed average DCO output frequency over fixed voltage and temperature range of 0–70°C | — | ± 0.3 | ± 1 | % f_{dco} | 1 | |
| f_{intf_ft} | Internal reference frequency (fast clock) — factory trimmed at nominal VDD and 25°C | — | 4 | — | MHz | | |
| f_{intf_t} | Internal reference frequency (fast clock) — user trimmed at nominal VDD and 25 °C | 3 | — | 5 | MHz | | |
| I_{intf} | Internal reference (fast clock) current | — | 25 | — | μA | | |
| f_{loc_low} | Loss of external clock minimum frequency — RANGE = 00 | $(3/5) \times f_{ints_t}$ | — | — | kHz | | |
| f_{loc_high} | Loss of external clock minimum frequency — RANGE = 01, 10, or 11 | $(16/5) \times f_{ints_t}$ | — | — | kHz | | |
| FLL | | | | | | | |
| f_{fill_ref} | FLL reference frequency range | 31.25 | — | 39.0625 | kHz | | |
| f_{dco} | DCO output frequency range | Low range (DRS=00) $640 \times f_{fill_ref}$ | 20 | 20.97 | 25 | MHz | 3, 4 |
| | | Mid range (DRS=01) $1280 \times f_{fill_ref}$ | 40 | 41.94 | 50 | MHz | |
| | | Mid-high range (DRS=10) $1920 \times f_{fill_ref}$ | 60 | 62.91 | 75 | MHz | |
| | | High range (DRS=11) $2560 \times f_{fill_ref}$ | 80 | 83.89 | 100 | MHz | |
| $f_{dco_t_DMX3}$ 2 | DCO output frequency | Low range (DRS=00) $732 \times f_{fill_ref}$ | — | 23.99 | — | MHz | 5, 6 |
| | | Mid range (DRS=01) $1464 \times f_{fill_ref}$ | — | 47.97 | — | MHz | |
| | | Mid-high range (DRS=10) | — | 71.99 | — | MHz | |

Table continues on the next page...



Table 15. MCG specifications (continued)

| Symbol | Description | Min. | Typ. | Max. | Unit | Notes |
|--------------------|---|------------|------|---|---------|-------|
| | | | | | | |
| | | | | | | |
| | | | | | | |
| J_{cyc_fll} | FLL period jitter <ul style="list-style-type: none"> $f_{DCO} = 48$ MHz $f_{DCO} = 98$ MHz | — | 180 | — | ps | |
| $t_{fll_acquire}$ | FLL target frequency acquisition time | — | — | 1 | ms | 7 |
| PLL | | | | | | |
| f_{vco} | VCO operating frequency | 48.0 | — | 120 | MHz | |
| I_{pll} | PLL operating current <ul style="list-style-type: none"> PLL @ 96 MHz ($f_{osc_hi_1} = 8$ MHz, $f_{pll_ref} = 2$ MHz, VDIV multiplier = 48) | — | 1060 | — | μ A | 8 |
| I_{pll} | PLL operating current <ul style="list-style-type: none"> PLL @ 48 MHz ($f_{osc_hi_1} = 8$ MHz, $f_{pll_ref} = 2$ MHz, VDIV multiplier = 24) | — | 600 | — | μ A | 8 |
| f_{pll_ref} | PLL reference frequency range | 2.0 | — | 4.0 | MHz | |
| J_{cyc_pll} | PLL period jitter (RMS) <ul style="list-style-type: none"> $f_{vco} = 48$ MHz $f_{vco} = 120$ MHz | — | 120 | — | ps | 9 |
| | | — | 75 | — | ps | |
| J_{acc_pll} | PLL accumulated jitter over 1 μ s (RMS) <ul style="list-style-type: none"> $f_{vco} = 48$ MHz $f_{vco} = 120$ MHz | — | 1350 | — | ps | 9 |
| | | — | 600 | — | ps | |
| D_{lock} | Lock entry frequency tolerance | ± 1.49 | — | ± 2.98 | % | |
| D_{unl} | Lock exit frequency tolerance | ± 4.47 | — | ± 5.97 | % | |
| t_{pll_lock} | Lock detector detection time | — | — | $150 \times 10^{-6} + 1075(1/f_{pll_ref})$ | s | 10 |

- This parameter is measured with the internal reference (slow clock) being used as a reference to the FLL (FEI clock mode).
- $2 V \leq VDD \leq 3.6 V$.
- These typical values listed are with the slow internal reference clock (FEI) using factory trim and DMX32=0.
- The resulting system clock frequencies should not exceed their maximum specified values. The DCO frequency deviation (Δf_{dco_t}) over voltage and temperature should be considered.
- These typical values listed are with the slow internal reference clock (FEI) using factory trim and DMX32=1.
- The resulting clock frequency must not exceed the maximum specified clock frequency of the device.
- This specification applies to any time the FLL reference source or reference divider is changed, trim value is changed, DMX32 bit is changed, DRS bits are changed, or changing from FLL disabled (BLPE, BLPI) to FLL enabled (FEI, FEE, FBE, FBI). If a crystal/resonator is being used as the reference, this specification assumes it is already running.
- Excludes any oscillator currents that are also consuming power while PLL is in operation.
- This specification was obtained using a Freescale developed PCB. PLL jitter is dependent on the noise characteristics of each PCB and results will vary.
- This specification applies to any time the PLL VCO divider or reference divider is changed, or changing from PLL disabled (BLPE, BLPI) to PLL enabled (PBE, PEE). If a crystal/resonator is being used as the reference, this specification assumes it is already running.

3.3.2 Oscillator electrical specifications

3.3.2.1 Oscillator DC electrical specifications

Table 16. Oscillator DC electrical specifications

| Symbol | Description | Min. | Typ. | Max. | Unit | Notes |
|--------------------|---|------|------|------|------|-------|
| V _{DD} | Supply voltage | 1.71 | — | 3.6 | V | |
| I _{DDOSC} | Supply current — low-power mode (HGO=0) <ul style="list-style-type: none"> • 32 kHz • 4 MHz • 8 MHz (RANGE=01) • 16 MHz • 24 MHz • 32 MHz | — | 600 | — | nA | 1 |
| | | — | 200 | — | μA | |
| | | — | 300 | — | μA | |
| | | — | 950 | — | μA | |
| | | — | 1.2 | — | mA | |
| | | — | 1.5 | — | mA | |
| I _{DDOSC} | Supply current — high gain mode (HGO=1) <ul style="list-style-type: none"> • 32 kHz • 4 MHz • 8 MHz (RANGE=01) • 16 MHz • 24 MHz • 32 MHz | — | 7.5 | — | μA | 1 |
| | | — | 500 | — | μA | |
| | | — | 650 | — | μA | |
| | | — | 2.5 | — | mA | |
| | | — | 3.25 | — | mA | |
| | | — | 4 | — | mA | |
| C _x | EXTAL load capacitance | — | — | — | | 2, 3 |
| C _y | XTAL load capacitance | — | — | — | | 2, 3 |
| R _F | Feedback resistor — low-frequency, low-power mode (HGO=0) | — | — | — | MΩ | 2, 4 |
| | Feedback resistor — low-frequency, high-gain mode (HGO=1) | — | 10 | — | MΩ | |
| | Feedback resistor — high-frequency, low-power mode (HGO=0) | — | — | — | MΩ | |
| | Feedback resistor — high-frequency, high-gain mode (HGO=1) | — | 1 | — | MΩ | |
| R _S | Series resistor — low-frequency, low-power mode (HGO=0) | — | — | — | kΩ | |
| | Series resistor — low-frequency, high-gain mode (HGO=1) | — | 200 | — | kΩ | |
| | Series resistor — high-frequency, low-power mode (HGO=0) | — | — | — | kΩ | |
| | Series resistor — high-frequency, high-gain mode (HGO=1) | | | | | |

Table continues on the next page...

Table 16. Oscillator DC electrical specifications (continued)

| Symbol | Description | Min. | Typ. | Max. | Unit | Notes |
|------------|--|------|----------|------|------------|-------|
| | | — | 0 | — | k Ω | |
| V_{pp}^5 | Peak-to-peak amplitude of oscillation (oscillator mode) — low-frequency, low-power mode (HGO=0) | — | 0.6 | — | V | |
| | Peak-to-peak amplitude of oscillation (oscillator mode) — low-frequency, high-gain mode (HGO=1) | — | V_{DD} | — | V | |
| | Peak-to-peak amplitude of oscillation (oscillator mode) — high-frequency, low-power mode (HGO=0) | — | 0.6 | — | V | |
| | Peak-to-peak amplitude of oscillation (oscillator mode) — high-frequency, high-gain mode (HGO=1) | — | V_{DD} | — | V | |

1. V_{DD} =3.3 V, Temperature =25 °C, Internal capacitance = 20 pf
2. See crystal or resonator manufacturer's recommendation
3. C_x, C_y can be provided by using either the integrated capacitors or by using external components.
4. When low power mode is selected, R_F is integrated and must not be attached externally.
5. The EXTAL and XTAL pins should only be connected to required oscillator components and must not be connected to any other devices.

3.3.2.2 Oscillator frequency specifications

Table 17. Oscillator frequency specifications

| Symbol | Description | Min. | Typ. | Max. | Unit | Notes |
|------------------|---|------|------|------|------|-------|
| f_{osc_lo} | Oscillator crystal or resonator frequency — low-frequency mode (MCG_C2[RANGE]=00) | 32 | — | 40 | kHz | |
| $f_{osc_hi_1}$ | Oscillator crystal or resonator frequency — high-frequency mode (low range) (MCG_C2[RANGE]=01) | 3 | — | 8 | MHz | |
| $f_{osc_hi_2}$ | Oscillator crystal or resonator frequency — high frequency mode (high range) (MCG_C2[RANGE]=1x) | 8 | — | 32 | MHz | |
| f_{ec_extal} | Input clock frequency (external clock mode) | — | — | 50 | MHz | 1, 2 |
| t_{dc_extal} | Input clock duty cycle (external clock mode) | 40 | 50 | 60 | % | |
| t_{cst} | Crystal startup time — 32 kHz low-frequency, low-power mode (HGO=0) | — | 750 | — | ms | 3, 4 |
| | Crystal startup time — 32 kHz low-frequency, high-gain mode (HGO=1) | — | 250 | — | ms | |
| | Crystal startup time — 8 MHz high-frequency (MCG_C2[RANGE]=01), low-power mode (HGO=0) | — | 0.6 | — | ms | |
| | Crystal startup time — 8 MHz high-frequency (MCG_C2[RANGE]=01), high-gain mode (HGO=1) | — | 1 | — | ms | |

1. Other frequency limits may apply when external clock is being used as a reference for the FLL or PLL.

Peripheral operating requirements and behaviors

- When transitioning from FEI or FBI to FBE mode, restrict the frequency of the input clock so that, when it is divided by FRDIV, it remains within the limits of the DCO input clock frequency.
- Proper PC board layout procedures must be followed to achieve specifications.
- Crystal startup time is defined as the time between the oscillator being enabled and the OSCINIT bit in the MCG_S register being set.

NOTE

The 32 kHz oscillator works in low power mode by default and cannot be moved into high power/gain mode.

3.3.3 32 kHz oscillator electrical characteristics

3.3.3.1 32 kHz oscillator DC electrical specifications

Table 18. 32kHz oscillator DC electrical specifications

| Symbol | Description | Min. | Typ. | Max. | Unit |
|------------|---|------|------|------|-----------|
| V_{BAT} | Supply voltage | 1.71 | — | 3.6 | V |
| R_F | Internal feedback resistor | — | 100 | — | $M\Omega$ |
| C_{para} | Parasitical capacitance of EXTAL32 and XTAL32 | — | 5 | 7 | pF |
| V_{pp}^1 | Peak-to-peak amplitude of oscillation | — | 0.6 | — | V |

- When a crystal is being used with the 32 kHz oscillator, the EXTAL32 and XTAL32 pins should only be connected to required oscillator components and must not be connected to any other devices.

3.3.3.2 32 kHz oscillator frequency specifications

Table 19. 32 kHz oscillator frequency specifications

| Symbol | Description | Min. | Typ. | Max. | Unit | Notes |
|-------------------|---|------|--------|-----------|------|-------|
| f_{osc_lo} | Oscillator crystal | — | 32.768 | — | kHz | |
| t_{start} | Crystal start-up time | — | 1000 | — | ms | 1 |
| $V_{ec_extal32}$ | Externally provided input clock amplitude | 700 | — | V_{BAT} | mV | 2, 3 |

- Proper PC board layout procedures must be followed to achieve specifications.
- This specification is for an externally supplied clock driven to EXTAL32 and does not apply to any other clock input. The oscillator remains enabled and XTAL32 must be left unconnected.
- The parameter specified is a peak-to-peak value and V_{IH} and V_{IL} specifications do not apply. The voltage of the applied clock must be within the range of V_{SS} to V_{BAT} .

3.4 Memories and memory interfaces

3.4.1 Flash (FTFE) electrical specifications

This section describes the electrical characteristics of the FTFE module.

3.4.1.1 Flash timing specifications — program and erase

The following specifications represent the amount of time the internal charge pumps are active and do not include command overhead.

Table 20. NVM program/erase timing specifications

| Symbol | Description | Min. | Typ. | Max. | Unit | Notes |
|--------------------|--|------|------|------|---------|-------|
| t_{hvpgm8} | Program Phrase high-voltage time | — | 7.5 | 18 | μ s | |
| $t_{hversscr}$ | Erase Flash Sector high-voltage time | — | 13 | 113 | ms | 1 |
| $t_{hversblk128k}$ | Erase Flash Block high-voltage time for 128 KB | — | 104 | 904 | ms | 1 |
| $t_{hversblk512k}$ | Erase Flash Block high-voltage time for 512 KB | — | 416 | 3616 | ms | 1 |

1. Maximum time based on expectations at cycling end-of-life.

3.4.1.2 Flash timing specifications — commands

Table 21. Flash command timing specifications

| Symbol | Description | Min. | Typ. | Max. | Unit | Notes |
|------------------|---|------|------|------|---------|-------|
| $t_{rd1blk128k}$ | Read 1s Block execution time | — | — | 0.5 | ms | |
| $t_{rd1blk512k}$ | <ul style="list-style-type: none"> 128 KB data flash 512 KB program flash | — | — | 1.8 | ms | |
| $t_{rd1sec4k}$ | Read 1s Section execution time (4 KB flash) | — | — | 100 | μ s | 1 |
| t_{pgmchk} | Program Check execution time | — | — | 95 | μ s | 1 |
| t_{rdsrc} | Read Resource execution time | — | — | 40 | μ s | 1 |
| t_{pgm8} | Program Phrase execution time | — | 90 | 150 | μ s | |
| $t_{ersblk128k}$ | Erase Flash Block execution time | — | 110 | 925 | ms | 2 |
| $t_{ersblk512k}$ | <ul style="list-style-type: none"> 128 KB data flash 512 KB program flash | — | 435 | 3700 | ms | |
| t_{ersscr} | Erase Flash Sector execution time | — | 15 | 115 | ms | 2 |
| $t_{pgmsec1k}$ | Program Section execution time (1KB flash) | — | 5 | — | ms | |
| $t_{rd1allx}$ | Read 1s All Blocks execution time | — | — | 2.2 | ms | |
| t_{rdonce} | Read Once execution time | — | — | 30 | μ s | 1 |
| $t_{pgmonce}$ | Program Once execution time | — | 90 | — | μ s | |
| t_{ersall} | Erase All Blocks execution time | — | 870 | 7400 | ms | 2 |
| t_{vfykey} | Verify Backdoor Access Key execution time | — | — | 30 | μ s | 1 |

Table continues on the next page...

Table 21. Flash command timing specifications (continued)

| Symbol | Description | Min. | Typ. | Max. | Unit | Notes |
|--|--|------|------|------|---------------|-------|
| $t_{\text{swap}01}$ | Swap Control execution time • control code 0x01 | — | 200 | — | μs | |
| $t_{\text{swap}02}$ | • control code 0x02 | — | 90 | 150 | μs | |
| $t_{\text{swap}04}$ | • control code 0x04 | — | 90 | 150 | μs | |
| $t_{\text{swap}08}$ | • control code 0x08 | — | — | 30 | μs | |
| $t_{\text{pgmpart}32\text{k}}$ | Program Partition for EEPROM execution time • 32 KB EEPROM backup | — | 70 | — | ms | |
| $t_{\text{pgmpart}128\text{k}}$ | • 128 KB EEPROM backup | — | 75 | — | ms | |
| t_{setramff} | Set FlexRAM Function execution time: • Control Code 0xFF | — | 70 | — | μs | |
| $t_{\text{setram}32\text{k}}$ | • 32 KB EEPROM backup | — | 0.8 | 1.2 | ms | |
| $t_{\text{setram}64\text{k}}$ | • 64 KB EEPROM backup | — | 1.3 | 1.9 | ms | |
| $t_{\text{setram}128\text{k}}$ | • 128 KB EEPROM backup | — | 2.4 | 3.1 | ms | |
| $t_{\text{eewr}8\text{bers}}$ | Byte-write to erased FlexRAM location execution time | — | 175 | 275 | μs | 3 |
| $t_{\text{eewr}8\text{b}32\text{k}}$ | Byte-write to FlexRAM execution time: • 32 KB EEPROM backup | — | 385 | 1700 | μs | |
| $t_{\text{eewr}8\text{b}64\text{k}}$ | • 64 KB EEPROM backup | — | 475 | 2000 | μs | |
| $t_{\text{eewr}8\text{b}128\text{k}}$ | • 128 KB EEPROM backup | — | 650 | 2350 | μs | |
| $t_{\text{eewr}16\text{bers}}$ | 16-bit write to erased FlexRAM location execution time | — | 175 | 275 | μs | |
| $t_{\text{eewr}16\text{b}32\text{k}}$ | 16-bit write to FlexRAM execution time: • 32 KB EEPROM backup | — | 385 | 1700 | μs | |
| $t_{\text{eewr}16\text{b}64\text{k}}$ | • 64 KB EEPROM backup | — | 475 | 2000 | μs | |
| $t_{\text{eewr}16\text{b}128\text{k}}$ | • 128 KB EEPROM backup | — | 650 | 2350 | μs | |
| $t_{\text{eewr}32\text{bers}}$ | 32-bit write to erased FlexRAM location execution time | — | 360 | 550 | μs | |
| $t_{\text{eewr}32\text{b}32\text{k}}$ | 32-bit write to FlexRAM execution time: • 32 KB EEPROM backup | — | 630 | 2000 | μs | |
| $t_{\text{eewr}32\text{b}64\text{k}}$ | • 64 KB EEPROM backup | — | 810 | 2250 | μs | |
| $t_{\text{eewr}32\text{b}128\text{k}}$ | • 128 KB EEPROM backup | — | 1200 | 2650 | μs | |

1. Assumes 25MHz or greater flash clock frequency.
2. Maximum times for erase parameters based on expectations at cycling end-of-life.
3. For byte-writes to an erased FlexRAM location, the aligned word containing the byte must be erased.

3.4.1.3 Flash high voltage current behaviors

Table 22. Flash high voltage current behaviors

| Symbol | Description | Min. | Typ. | Max. | Unit |
|---------------------|---|------|------|------|------|
| I _{DD_PGM} | Average current adder during high voltage flash programming operation | — | 3.5 | 7.5 | mA |
| I _{DD_ERS} | Average current adder during high voltage flash erase operation | — | 1.5 | 4.0 | mA |

3.4.1.4 Reliability specifications

Table 23. NVM reliability specifications

| Symbol | Description | Min. | Typ. ¹ | Max. | Unit | Notes |
|---------------------------|--|-------|-------------------|------|--------|-------|
| Program Flash | | | | | | |
| t _{nvmpretp10k} | Data retention after up to 10 K cycles | 5 | 50 | — | years | |
| t _{nvmpretp1k} | Data retention after up to 1 K cycles | 20 | 100 | — | years | |
| n _{nvmpcyp} | Cycling endurance | 10 K | 50 K | — | cycles | 2 |
| Data Flash | | | | | | |
| t _{nvmdretd10k} | Data retention after up to 10 K cycles | 5 | 50 | — | years | |
| t _{nvmdretd1k} | Data retention after up to 1 K cycles | 20 | 100 | — | years | |
| n _{nvmdcycd} | Cycling endurance | 10 K | 50 K | — | cycles | 2 |
| FlexRAM as EEPROM | | | | | | |
| t _{nvmdretee100} | Data retention up to 100% of write endurance | 5 | 50 | — | years | |
| t _{nvmdretee10} | Data retention up to 10% of write endurance | 20 | 100 | — | years | |
| n _{nvmdcycee} | Cycling endurance for EEPROM backup | 20 K | 50 K | — | cycles | 2 |
| n _{nvmdwree16} | Write endurance | 70 K | 175 K | — | writes | 3 |
| n _{nvmdwree128} | • EEPROM backup to FlexRAM ratio = 16 | 630 K | 1.6 M | — | writes | |
| n _{nvmdwree512} | • EEPROM backup to FlexRAM ratio = 128 | 2.5 M | 6.4 M | — | writes | |
| n _{nvmdwree2k} | • EEPROM backup to FlexRAM ratio = 512 | 10 M | 25 M | — | writes | |
| n _{nvmdwree4k} | • EEPROM backup to FlexRAM ratio = 2,048 | 20 M | 50 M | — | writes | |
| | • EEPROM backup to FlexRAM ratio = 4,096 | | | | | |

1. Typical data retention values are based on measured response accelerated at high temperature and derated to a constant 25°C use profile. Engineering Bulletin EB618 does not apply to this technology. Typical endurance defined in Engineering Bulletin EB619.
2. Cycling endurance represents number of program/erase cycles at $-40^{\circ}\text{C} \leq T_j \leq 125^{\circ}\text{C}$.
3. Write endurance represents the number of writes to each FlexRAM location at $-40^{\circ}\text{C} \leq T_j \leq 125^{\circ}\text{C}$ influenced by the cycling endurance of the FlexNVM (same value as data flash) and the allocated EEPROM backup per subsystem. Minimum and typical values assume all byte-writes to FlexRAM.

3.4.1.5 Write endurance to FlexRAM for EEPROM

When the FlexNVM partition code is not set to full data flash, the EEPROM data set size can be set to any of several non-zero values.

The bytes not assigned to data flash via the FlexNVM partition code are used by the FTFE to obtain an effective endurance increase for the EEPROM data. The built-in EEPROM record management system raises the number of program/erase cycles that can be attained prior to device wear-out by cycling the EEPROM data through a larger EEPROM NVM storage space.

While different partitions of the FlexNVM are available, the intention is that a single choice for the FlexNVM partition code and EEPROM data set size is used throughout the entire lifetime of a given application. The EEPROM endurance equation and graph shown below assume that only one configuration is ever used.

$$\text{Writes_subsystem} = \frac{\text{EEPROM} - 2 \times \text{EEESPLIT} \times \text{EEESIZE}}{\text{EEESPLIT} \times \text{EEESIZE}} \times \text{Write_efficiency} \times n_{\text{nvmcycee}}$$

where

- Writes_subsystem — minimum number of writes to each FlexRAM location for subsystem (each subsystem can have different endurance)
- EEPROM — allocated FlexNVM for each EEPROM subsystem based on DEPART; entered with the Program Partition command
- EEESPLIT — FlexRAM split factor for subsystem; entered with the Program Partition command
- EEESIZE — allocated FlexRAM based on DEPART; entered with the Program Partition command
- Write_efficiency —
 - 0.25 for 8-bit writes to FlexRAM
 - 0.50 for 16-bit or 32-bit writes to FlexRAM
- n_{nvmcycee} — EEPROM-backup cycling endurance

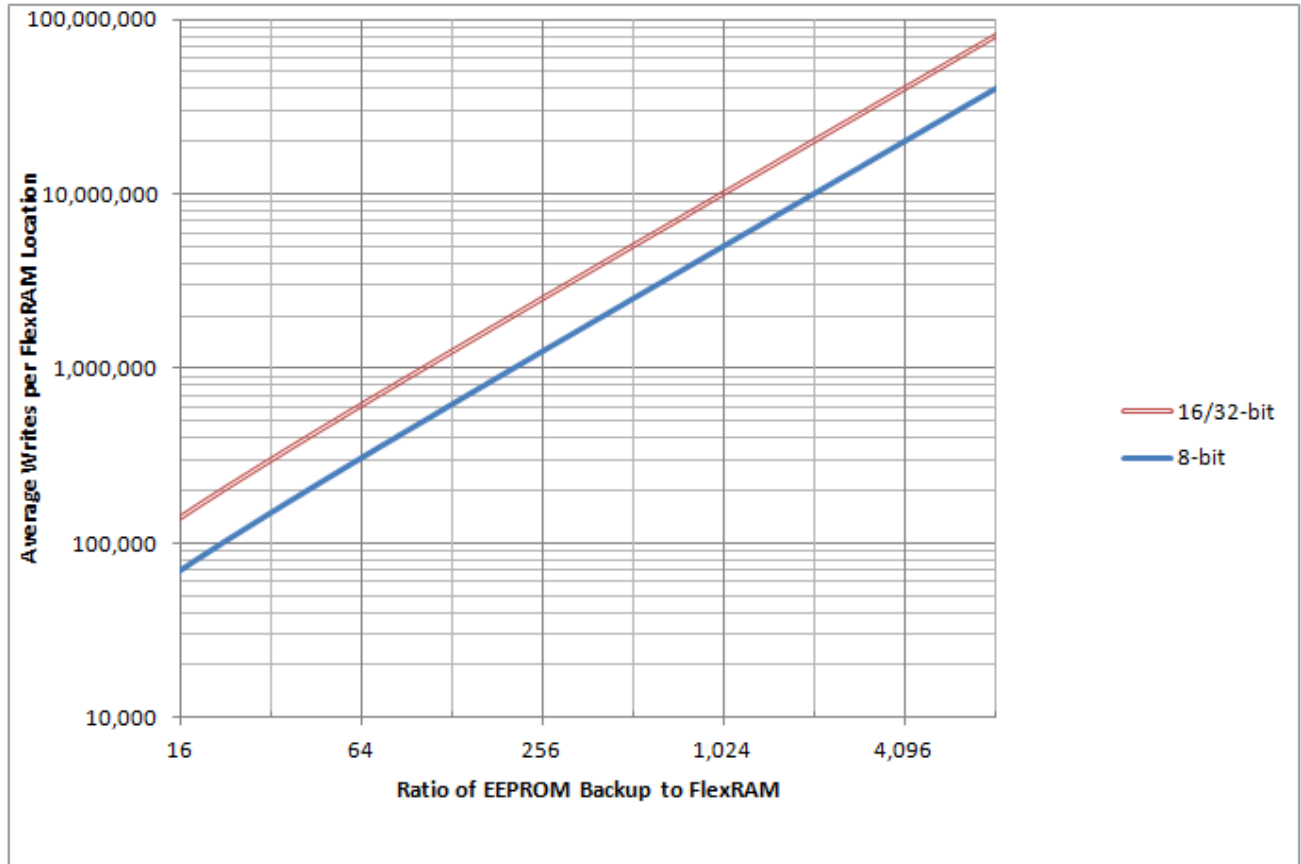

Figure 11. EEPROM backup writes to FlexRAM

3.4.2 EzPort switching specifications

Table 24. EzPort switching specifications

| Num | Description | Min. | Max. | Unit |
|------|--|------------------------|-------------|------|
| | Operating voltage | 1.71 | 3.6 | V |
| EP1 | EZP_CK frequency of operation (all commands except READ) | — | $f_{SYS}/2$ | MHz |
| EP1a | EZP_CK frequency of operation (READ command) | — | $f_{SYS}/8$ | MHz |
| EP2 | $\overline{EZP_CS}$ negation to next EZP_CS assertion | $2 \times t_{EZP_CK}$ | — | ns |
| EP3 | $\overline{EZP_CS}$ input valid to EZP_CK high (setup) | 5 | — | ns |
| EP4 | EZP_CK high to $\overline{EZP_CS}$ input invalid (hold) | 5 | — | ns |
| EP5 | EZP_D input valid to EZP_CK high (setup) | 2 | — | ns |
| EP6 | EZP_CK high to EZP_D input invalid (hold) | 5 | — | ns |
| EP7 | EZP_CK low to EZP_Q output valid | — | 18 | ns |
| EP8 | EZP_CK low to EZP_Q output invalid (hold) | 0 | — | ns |
| EP9 | $\overline{EZP_CS}$ negation to EZP_Q tri-state | — | 12 | ns |

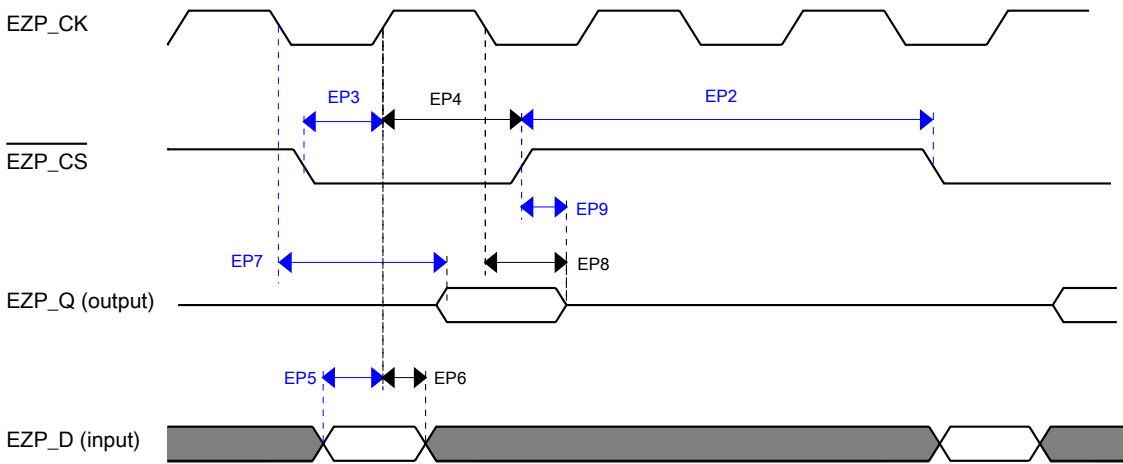

Figure 12. EzPort Timing Diagram

3.4.3 Flexbus switching specifications

All processor bus timings are synchronous; input setup/hold and output delay are given in respect to the rising edge of a reference clock, FB_CLK. The FB_CLK frequency may be the same as the internal system bus frequency or an integer divider of that frequency.

The following timing numbers indicate when data is latched or driven onto the external bus, relative to the Flexbus output clock (FB_CLK). All other timing relationships can be derived from these values.

Table 25. Flexbus limited voltage range switching specifications

| Num | Description | Min. | Max. | Unit | Notes |
|-----|---|------|--------|------|-------|
| | Operating voltage | 2.7 | 3.6 | V | |
| | Frequency of operation | — | FB_CLK | MHz | |
| FB1 | Clock period | 20 | — | ns | |
| FB2 | Address, data, and control output valid | — | 11.5 | ns | 1 |
| FB3 | Address, data, and control output hold | 0.5 | — | ns | 1 |
| FB4 | Data and $\overline{\text{FB_TA}}$ input setup | 8.5 | — | ns | 2 |
| FB5 | Data and $\overline{\text{FB_TA}}$ input hold | 0.5 | — | ns | 2 |

1. Specification is valid for all FB_AD[31:0], $\overline{\text{FB_BE/BWE}n}$, $\overline{\text{FB_CS}n}$, FB_OE, FB_R/W, FB_TBST, FB_TSIz[1:0], FB_ALE, and FB_TS.

- Specification is valid for all FB_AD[31:0] and $\overline{\text{FB_TA}}$.

Table 26. Flexbus full voltage range switching specifications

| Num | Description | Min. | Max. | Unit | Notes |
|-----|---|----------|--------|------|-------|
| | Operating voltage | 1.71 | 3.6 | V | |
| | Frequency of operation | — | FB_CLK | MHz | |
| FB1 | Clock period | 1/FB_CLK | — | ns | |
| FB2 | Address, data, and control output valid | — | 13.5 | ns | 1 |
| FB3 | Address, data, and control output hold | 0 | — | ns | 1 |
| FB4 | Data and $\overline{\text{FB_TA}}$ input setup | 13.7 | — | ns | 2 |
| FB5 | Data and $\overline{\text{FB_TA}}$ input hold | 0.5 | — | ns | 2 |

- Specification is valid for all FB_AD[31:0], $\overline{\text{FB_BE/BWE}n}$, $\overline{\text{FB_CS}n}$, $\overline{\text{FB_OE}}$, $\overline{\text{FB_R/W}}$, $\overline{\text{FB_TBST}}$, FB_TSIZ[1:0], FB_ALE, and $\overline{\text{FB_TS}}$.
- Specification is valid for all FB_AD[31:0] and $\overline{\text{FB_TA}}$.

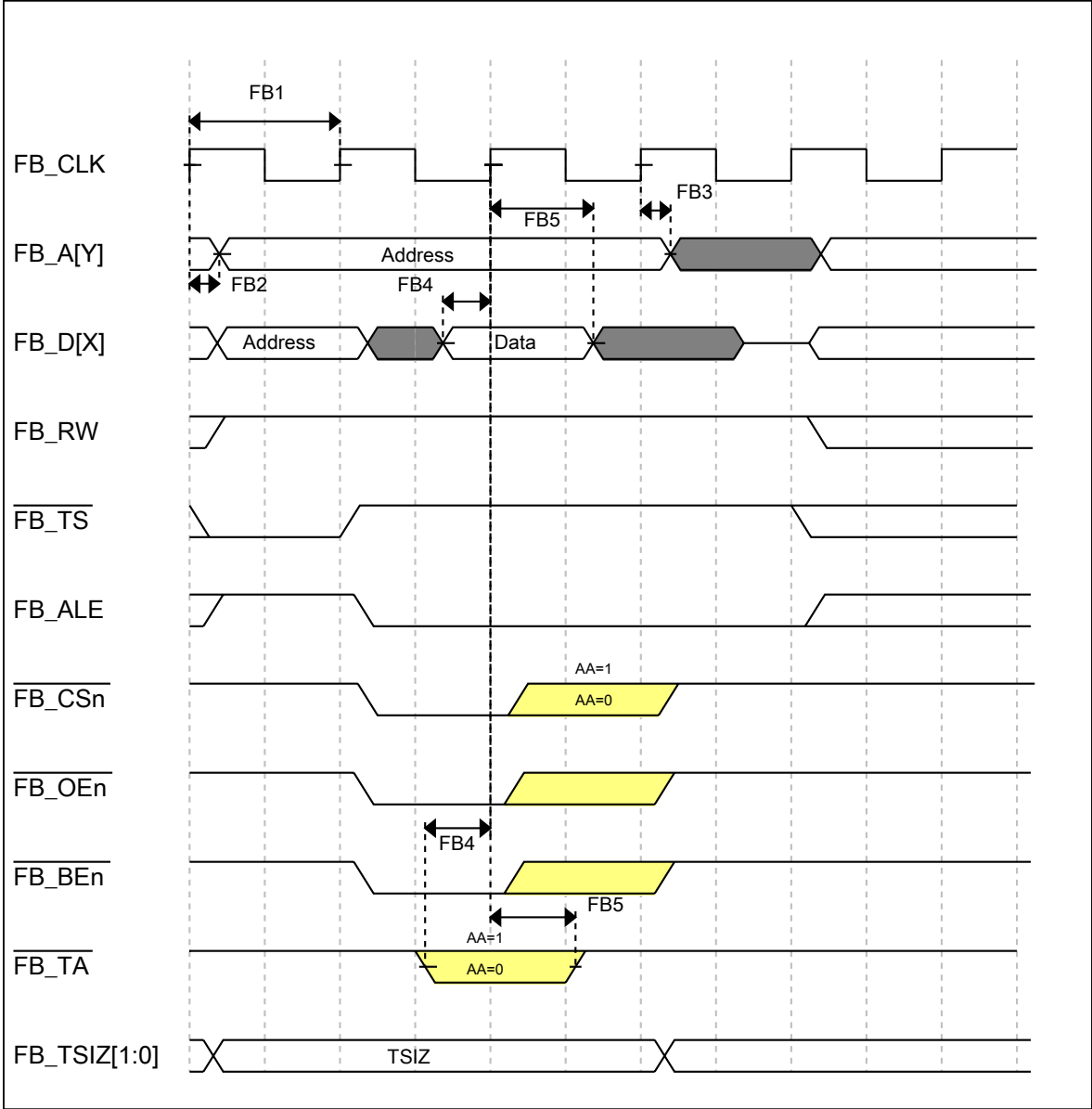

Figure 13. FlexBus read timing diagram

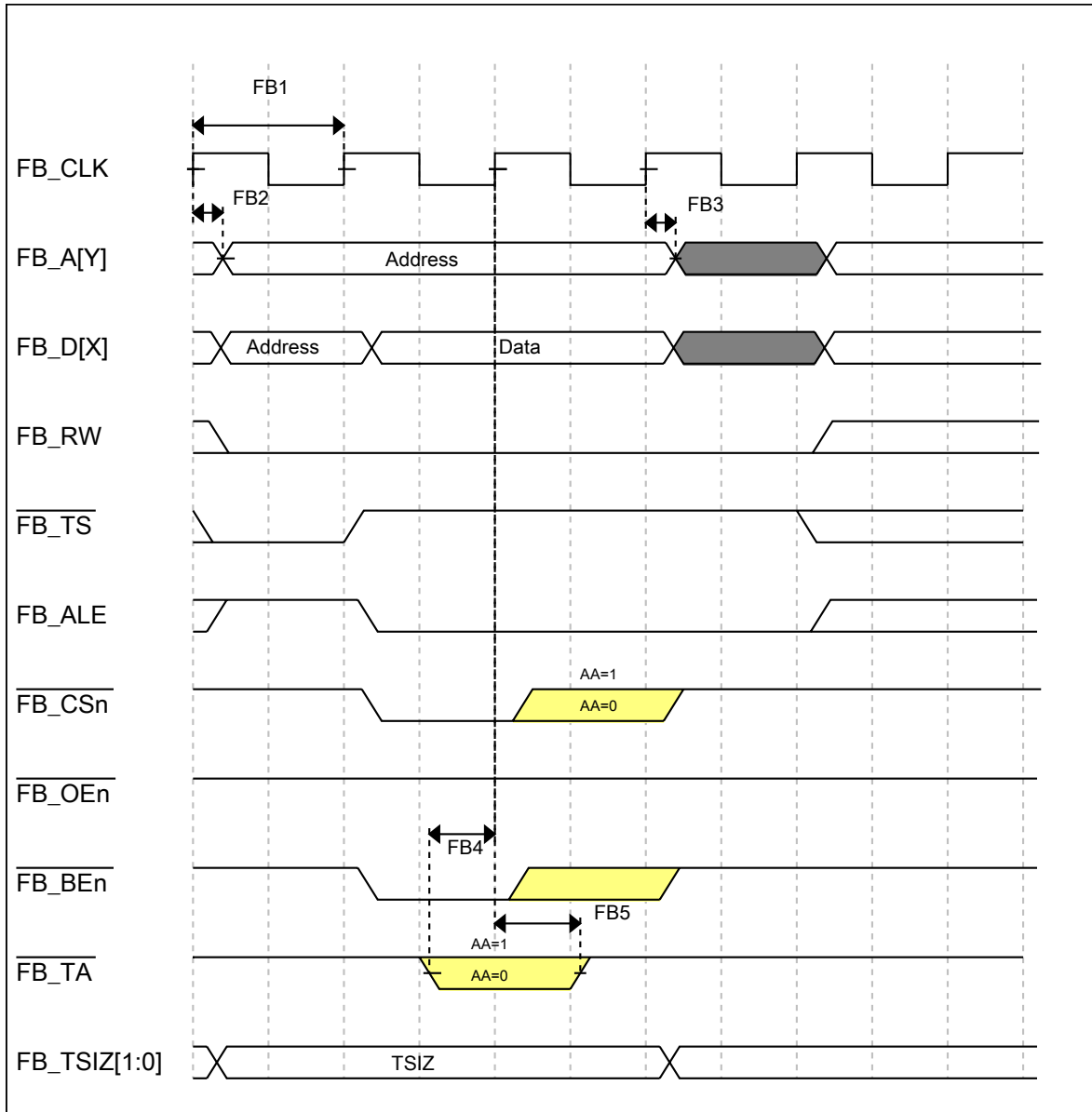

Figure 14. FlexBus write timing diagram

3.5 Security and integrity modules

3.5.1 DryIce Tamper Electrical Specifications

Information about security-related modules is not included in this document and is available only after a nondisclosure agreement (NDA) has been signed. To request an NDA, please contact your local Freescale sales representative.

3.6 Analog

3.6.1 ADC electrical specifications

The 16-bit accuracy specifications listed in [Table 27](#) and [Table 28](#) are achievable on the differential pins ADC_X_DP0, ADC_X_DM0.

All other ADC channels meet the 13-bit differential/12-bit single-ended accuracy specifications.

3.6.1.1 16-bit ADC operating conditions

Table 27. 16-bit ADC operating conditions

| Symbol | Description | Conditions | Min. | Typ. ¹ | Max. | Unit | Notes |
|-------------------|-------------------------------------|--|--|-------------------|--|------|-------|
| V _{DDA} | Supply voltage | Absolute | 1.71 | — | 3.6 | V | — |
| ΔV _{DDA} | Supply voltage | Delta to V _{DD} (V _{DD} – V _{DDA}) | -100 | 0 | +100 | mV | 2 |
| ΔV _{SSA} | Ground voltage | Delta to V _{SS} (V _{SS} – V _{SSA}) | -100 | 0 | +100 | mV | 2 |
| V _{REFH} | ADC reference voltage high | | 1.13 | V _{DDA} | V _{DDA} | V | |
| V _{REFL} | ADC reference voltage low | | V _{SSA} | V _{SSA} | V _{SSA} | V | |
| V _{ADIN} | Input voltage | <ul style="list-style-type: none"> 16-bit differential mode All other modes | V _{REFL} V _{REFL} | — — | 31/32 * V _{REFH} V _{REFH} | V | — |
| C _{ADIN} | Input capacitance | <ul style="list-style-type: none"> 16-bit mode 8-bit / 10-bit / 12-bit modes | — — | 8 4 | 10 5 | pF | — |
| R _{ADIN} | Input series resistance | | — | 2 | 5 | kΩ | — |
| R _{AS} | Analog source resistance (external) | 13-bit / 12-bit modes f _{ADCK} < 4 MHz | — | — | 5 | kΩ | 3 |
| f _{ADCK} | ADC conversion clock frequency | ≤ 13-bit mode | 1.0 | — | 18.0 | MHz | 4 |
| f _{ADCK} | ADC conversion clock frequency | 16-bit mode | 2.0 | — | 12.0 | MHz | 4 |
| C _{rate} | ADC conversion rate | ≤ 13-bit modes No ADC hardware averaging | 20.000 | — | 818.330 | Ksps | 5 |

Table continues on the next page...

Table 27. 16-bit ADC operating conditions (continued)

| Symbol | Description | Conditions | Min. | Typ. ¹ | Max. | Unit | Notes |
|------------|---------------------|--|--------|-------------------|---------|------|-------|
| | | Continuous conversions enabled, subsequent conversion time | | | | | |
| C_{rate} | ADC conversion rate | 16-bit mode No ADC hardware averaging Continuous conversions enabled, subsequent conversion time | 37.037 | — | 461.467 | Ksps | 5 |

1. Typical values assume $V_{DDA} = 3.0\text{ V}$, $Temp = 25\text{ }^{\circ}\text{C}$, $f_{ADCK} = 1.0\text{ MHz}$, unless otherwise stated. Typical values are for reference only, and are not tested in production.
2. DC potential difference.
3. This resistance is external to MCU. To achieve the best results, the analog source resistance must be kept as low as possible. The results in this data sheet were derived from a system that had $< 8\ \Omega$ analog source resistance. The R_{AS}/C_{AS} time constant should be kept to $< 1\text{ ns}$.
4. To use the maximum ADC conversion clock frequency, $CFG2[ADHSC]$ must be set and $CFG1[ADLPC]$ must be clear.
5. For guidelines and examples of conversion rate calculation, download the [ADC calculator tool](#).

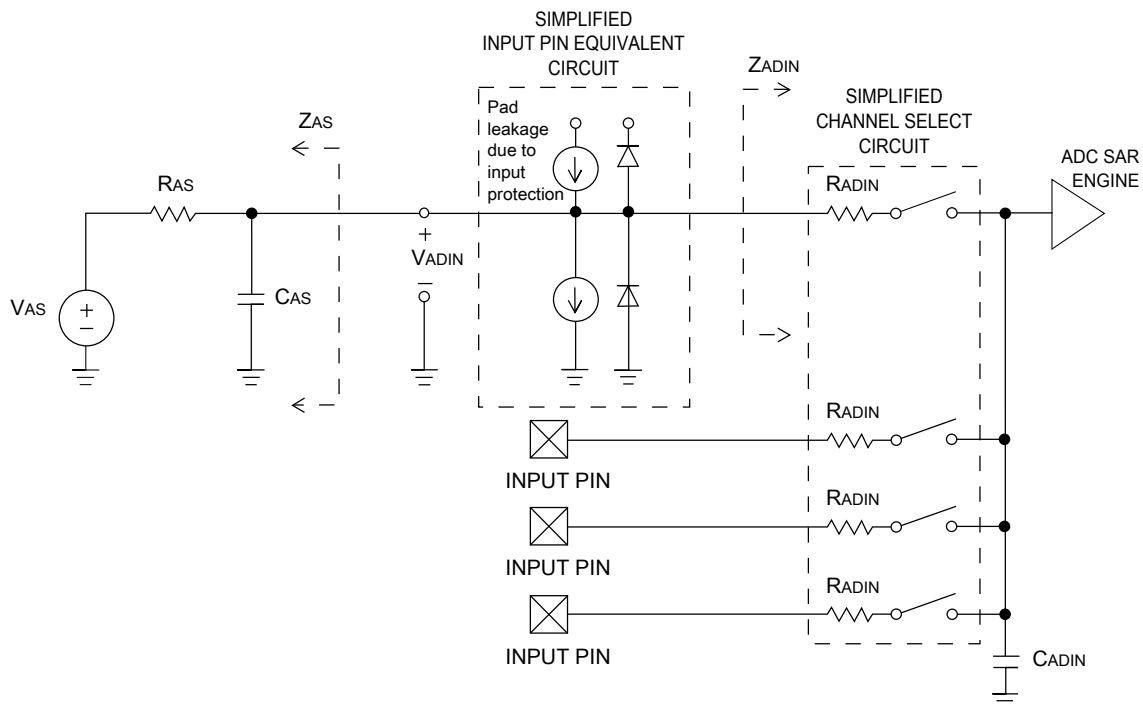
Figure 15. ADC input impedance equivalency diagram

3.6.1.2 16-bit ADC electrical characteristics

Table 28. 16-bit ADC characteristics ($V_{REFH} = V_{DDA}$, $V_{REFL} = V_{SSA}$)

| Symbol | Description | Conditions ¹ | Min. | Typ. ² | Max. | Unit | Notes |
|----------------|---------------------------------|---|--------------------|-------------------|--------------|------------------|-----------------------------------|
| I_{DDA_ADC} | Supply current | | 0.215 | — | 1.7 | mA | 3 |
| f_{ADACK} | ADC asynchronous clock source | <ul style="list-style-type: none"> • ADLPC = 1, ADHSC = 0 • ADLPC = 1, ADHSC = 1 • ADLPC = 0, ADHSC = 0 • ADLPC = 0, ADHSC = 1 | 1.2 | 2.4 | 3.9 | MHz | $t_{ADACK} = 1/f_{ADACK}$ |
| | | | 2.4 | 4.0 | 6.1 | MHz | |
| | | | 3.0 | 5.2 | 7.3 | MHz | |
| | | | 4.4 | 6.2 | 9.5 | MHz | |
| | Sample Time | See Reference Manual chapter for sample times | | | | | |
| TUE | Total unadjusted error | <ul style="list-style-type: none"> • 12-bit modes • <12-bit modes | — | ±4 | ±6.8 | LSB ⁴ | 5 |
| | | | — | ±1.4 | ±2.1 | | |
| DNL | Differential non-linearity | <ul style="list-style-type: none"> • 12-bit modes • <12-bit modes | — | ±0.7 | -1.1 to +1.9 | LSB ⁴ | 5 |
| | | | — | ±0.2 | -0.3 to 0.5 | | |
| INL | Integral non-linearity | <ul style="list-style-type: none"> • 12-bit modes • <12-bit modes | — | ±1.0 | -2.7 to +1.9 | LSB ⁴ | 5 |
| | | | — | ±0.5 | -0.7 to +0.5 | | |
| E_{FS} | Full-scale error | <ul style="list-style-type: none"> • 12-bit modes • <12-bit modes | — | -4 | -5.4 | LSB ⁴ | $V_{ADIN} = V_{DDA}$ ⁵ |
| | | | — | -1.4 | -1.8 | | |
| E_Q | Quantization error | <ul style="list-style-type: none"> • 16-bit modes • ≤13-bit modes | — | -1 to 0 | — | LSB ⁴ | |
| | | | — | — | ±0.5 | | |
| ENOB | Effective number of bits | 16-bit differential mode <ul style="list-style-type: none"> • Avg = 32 • Avg = 4 16-bit single-ended mode <ul style="list-style-type: none"> • Avg = 32 • Avg = 4 | 12.8 | 14.5 | — | bits | 6 |
| | | | 11.9 | 13.8 | — | bits | |
| | | | 12.2 | 13.9 | — | bits | |
| | | | 11.4 | 13.1 | — | bits | |
| SINAD | Signal-to-noise plus distortion | See ENOB | 6.02 × ENOB + 1.76 | | | dB | |
| THD | Total harmonic distortion | 16-bit differential mode <ul style="list-style-type: none"> • Avg = 32 16-bit single-ended mode <ul style="list-style-type: none"> • Avg = 32 | — | -94 | — | dB | 7 |
| | | | — | -85 | — | dB | |
| SFDR | Spurious free dynamic range | 16-bit differential mode <ul style="list-style-type: none"> • Avg = 32 16-bit single-ended mode | 82 | 95 | — | dB | 7 |
| | | | 78 | 90 | — | dB | |

Table continues on the next page...

Table 28. 16-bit ADC characteristics ($V_{REFH} = V_{DDA}$, $V_{REFL} = V_{SSA}$) (continued)

| Symbol | Description | Conditions ¹ | Min. | Typ. ² | Max. | Unit | Notes |
|--------------|---------------------|---|------------------------|-------------------|------|-------|---|
| | | • Avg = 32 | | | | | |
| E_{IL} | Input leakage error | | $I_{in} \times R_{AS}$ | | | mV | I_{in} = leakage current (refer to the MCU's voltage and current operating ratings) |
| | Temp sensor slope | Across the full temperature range of the device | 1.55 | 1.62 | 1.69 | mV/°C | 8 |
| V_{TEMP25} | Temp sensor voltage | 25 °C | 706 | 716 | 726 | mV | 8 |

- All accuracy numbers assume the ADC is calibrated with $V_{REFH} = V_{DDA}$
- Typical values assume $V_{DDA} = 3.0$ V, Temp = 25 °C, $f_{ADCK} = 2.0$ MHz unless otherwise stated. Typical values are for reference only and are not tested in production.
- The ADC supply current depends on the ADC conversion clock speed, conversion rate and ADC_CFG1[ADLPC] (low power). For lowest power operation, ADC_CFG1[ADLPC] must be set, the ADC_CFG2[ADHSC] bit must be clear with 1 MHz ADC conversion clock speed.
- 1 LSB = $(V_{REFH} - V_{REFL})/2^N$
- ADC conversion clock < 16 MHz, Max hardware averaging (AVGE = %1, AVGS = %11)
- Input data is 100 Hz sine wave. ADC conversion clock < 12 MHz.
- Input data is 1 kHz sine wave. ADC conversion clock < 12 MHz.
- ADC conversion clock < 3 MHz

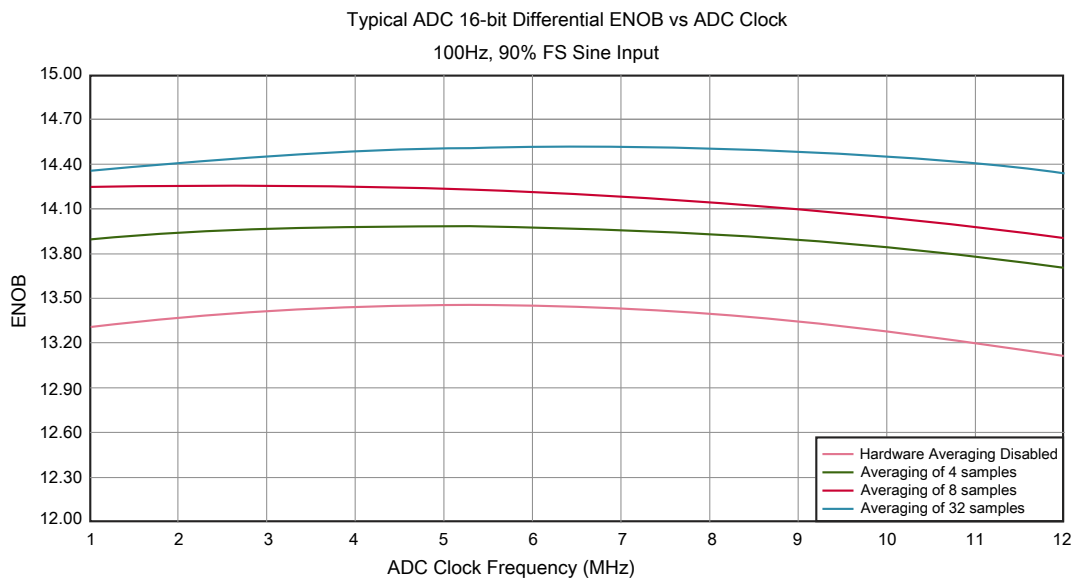
Figure 16. Typical ENOB vs. ADC_CLK for 16-bit differential mode

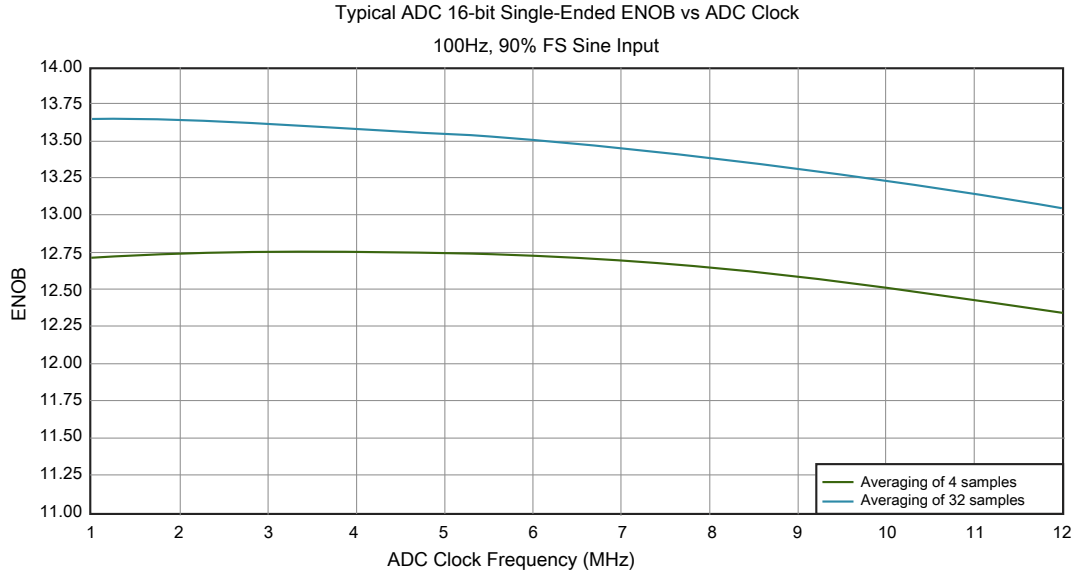

Figure 17. Typical ENOB vs. ADC_CLK for 16-bit single-ended mode

3.6.2 CMP and 6-bit DAC electrical specifications

Table 29. Comparator and 6-bit DAC electrical specifications

| Symbol | Description | Min. | Typ. | Max. | Unit |
|-------------|---|----------------|------|----------|------------------|
| V_{DD} | Supply voltage | 1.71 | — | 3.6 | V |
| I_{DDHS} | Supply current, High-speed mode (EN=1, PMODE=1) | — | — | 200 | μ A |
| $I_{DDL S}$ | Supply current, low-speed mode (EN=1, PMODE=0) | — | — | 20 | μ A |
| V_{AIN} | Analog input voltage | $V_{SS} - 0.3$ | — | V_{DD} | V |
| V_{AIO} | Analog input offset voltage | — | — | 20 | mV |
| V_H | Analog comparator hysteresis ¹ | | | | |
| | • CR0[HYSTCTR] = 00 | — | 5 | — | mV |
| | • CR0[HYSTCTR] = 01 | — | 10 | — | mV |
| | • CR0[HYSTCTR] = 10 | — | 20 | — | mV |
| | • CR0[HYSTCTR] = 11 | — | 30 | — | mV |
| V_{CMPOh} | Output high | $V_{DD} - 0.5$ | — | — | V |
| V_{CMPOl} | Output low | — | — | 0.5 | V |
| t_{DHS} | Propagation delay, high-speed mode (EN=1, PMODE=1) | 20 | 50 | 200 | ns |
| t_{DLS} | Propagation delay, low-speed mode (EN=1, PMODE=0) | 80 | 250 | 600 | ns |
| | Analog comparator initialization delay ² | — | — | 40 | μ s |
| I_{DAC6b} | 6-bit DAC current adder (enabled) | — | 7 | — | μ A |
| INL | 6-bit DAC integral non-linearity | -0.5 | — | 0.5 | LSB ³ |
| DNL | 6-bit DAC differential non-linearity | -0.3 | — | 0.3 | LSB |

1. Typical hysteresis is measured with input voltage range limited to 0.6 to $V_{DD}-0.6$ V.
2. Comparator initialization delay is defined as the time between software writes to change control inputs (Writes to CMP_DACCR[DACEN], CMP_DACCR[VRSEL], CMP_DACCR[VOSEL], CMP_MUXCR[PSEL], and CMP_MUXCR[MSEL]) and the comparator output settling to a stable level.
3. $1 \text{ LSB} = V_{\text{reference}}/64$

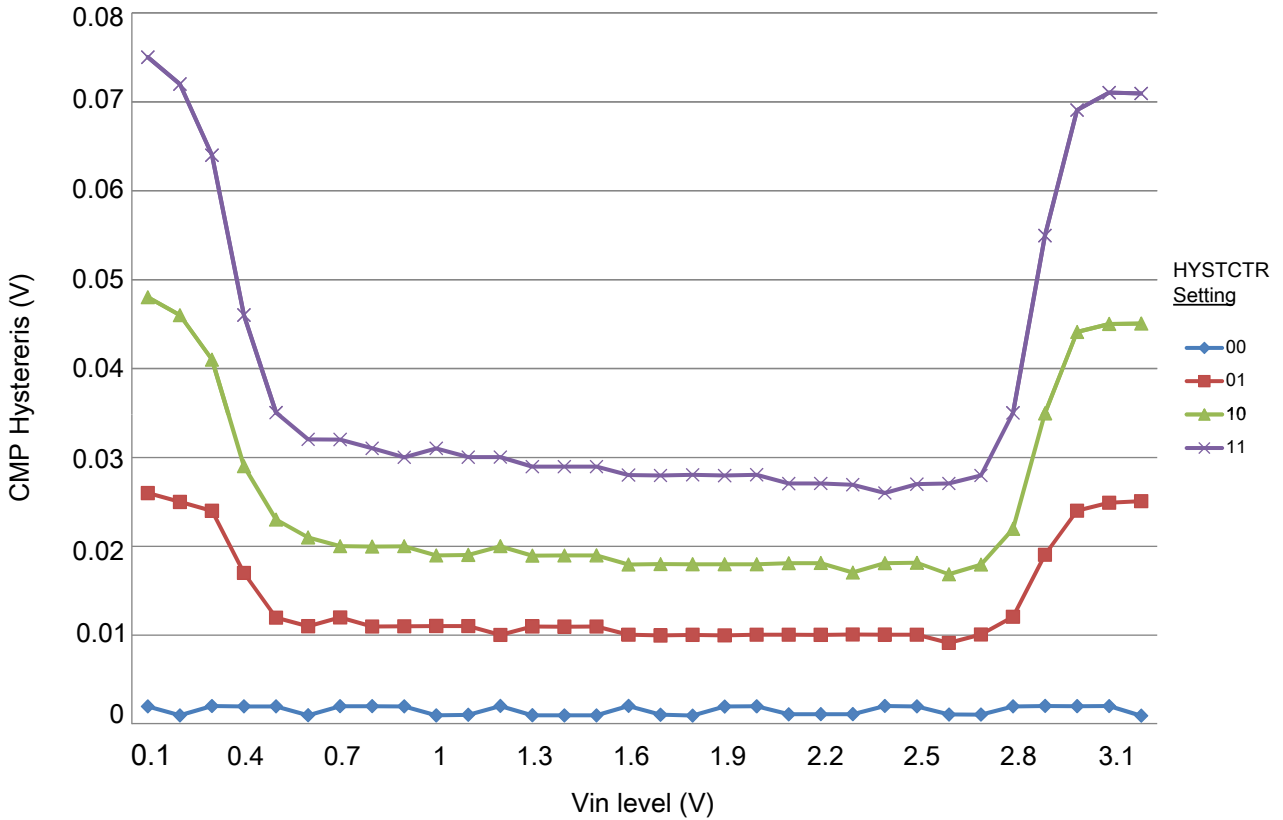

Figure 18. Typical hysteresis vs. Vin level (VDD = 3.3 V, PMODE = 0)

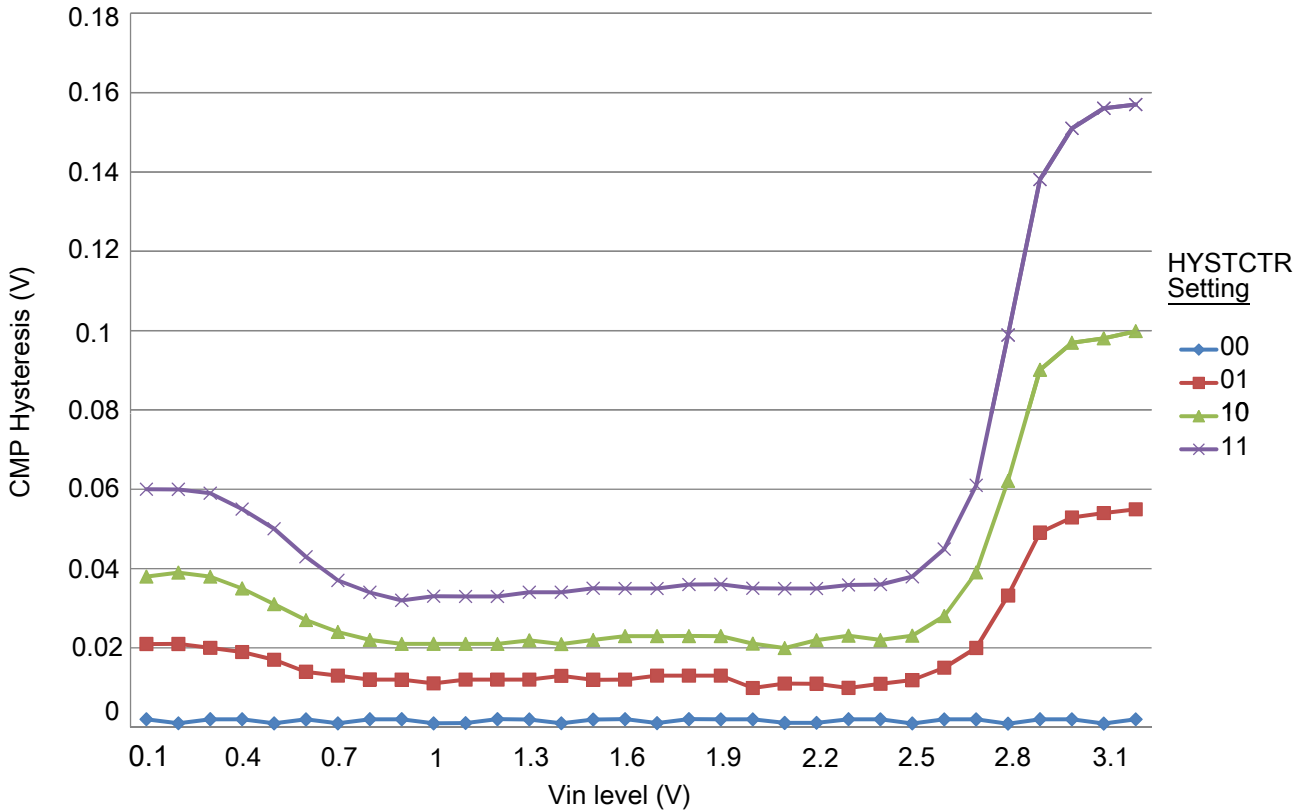

Figure 19. Typical hysteresis vs. Vin level (VDD = 3.3 V, PMODE = 1)

3.6.3 12-bit DAC electrical characteristics

3.6.3.1 12-bit DAC operating requirements

Table 30. 12-bit DAC operating requirements

| Symbol | Description | Min. | Max. | Unit | Notes |
|------------|-------------------------|------|------|------|-------|
| V_{DDA} | Supply voltage | 1.71 | 3.6 | V | |
| V_{DACR} | Reference voltage | 1.13 | 3.6 | V | 1 |
| C_L | Output load capacitance | — | 100 | pF | 2 |
| I_L | Output load current | — | 1 | mA | |

1. The DAC reference can be selected to be V_{DDA} or V_{REFH} .
2. A small load capacitance (47 pF) can improve the bandwidth performance of the DAC.

3.6.3.2 12-bit DAC operating behaviors

Table 31. 12-bit DAC operating behaviors

| Symbol | Description | Min. | Typ. | Max. | Unit | Notes |
|------------------|---|------------------|-------------|------------|-------------------------|-------|
| I_{DDA_DACLP} | Supply current — low-power mode | — | — | 150 | μA | |
| I_{DDA_DACHP} | Supply current — high-speed mode | — | — | 700 | μA | |
| t_{DACLP} | Full-scale settling time (0x080 to 0xF7F) — low-power mode | — | 100 | 200 | μs | 1 |
| t_{DACHP} | Full-scale settling time (0x080 to 0xF7F) — high-power mode | — | 15 | 30 | μs | 1 |
| $t_{CCDACLP}$ | Code-to-code settling time (0xBF8 to 0xC08) — low-power mode and high-speed mode | — | 0.7 | 1 | μs | 1 |
| $V_{dacoutl}$ | DAC output voltage range low — high-speed mode, no load, DAC set to 0x000 | — | — | 100 | mV | |
| $V_{dacouth}$ | DAC output voltage range high — high-speed mode, no load, DAC set to 0xFFFF | $V_{DACR} - 100$ | — | V_{DACR} | mV | |
| INL | Integral non-linearity error — high speed mode | — | — | ± 8 | LSB | 2 |
| DNL | Differential non-linearity error — $V_{DACR} > 2\text{ V}$ | — | — | ± 1 | LSB | 3 |
| DNL | Differential non-linearity error — $V_{DACR} = V_{REF_OUT}$ | — | — | ± 1 | LSB | 4 |
| V_{OFFSET} | Offset error | — | ± 0.4 | ± 0.8 | %FSR | 5 |
| E_G | Gain error | — | ± 0.1 | ± 0.6 | %FSR | 5 |
| PSRR | Power supply rejection ratio, $V_{DDA} \geq 2.4\text{ V}$ | 60 | — | 90 | dB | |
| T_{CO} | Temperature coefficient offset voltage | — | 3.7 | — | $\mu\text{V}/\text{C}$ | 6 |
| T_{GE} | Temperature coefficient gain error | — | 0.000421 | — | %FSR/C | |
| A_C | Offset aging coefficient | — | — | 100 | $\mu\text{V}/\text{yr}$ | |
| R_{op} | Output resistance (load = 3 k Ω) | — | — | 250 | Ω | |
| SR | Slew rate -80h → F7Fh → 80h <ul style="list-style-type: none"> • High power (SP_{HP}) • Low power (SP_{LP}) | 1.2 0.05 | 1.7 0.12 | — — | V/ μs | |
| CT | Channel to channel cross talk | — | — | -80 | dB | |
| BW | 3dB bandwidth <ul style="list-style-type: none"> • High power (SP_{HP}) • Low power (SP_{LP}) | 550 40 | — — | — — | kHz | |

1. Settling within ± 1 LSB
2. The INL is measured for 0 + 100 mV to $V_{DACR} - 100\text{ mV}$
3. The DNL is measured for 0 + 100 mV to $V_{DACR} - 100\text{ mV}$
4. The DNL is measured for 0 + 100 mV to $V_{DACR} - 100\text{ mV}$ with $V_{DDA} > 2.4\text{ V}$
5. Calculated by a best fit curve from $V_{SS} + 100\text{ mV}$ to $V_{DACR} - 100\text{ mV}$

Peripheral operating requirements and behaviors

- 6. $V_{DDA} = 3.0\text{ V}$, reference select set for V_{DDA} ($\text{DACx_CO:DACRFS} = 1$), high power mode ($\text{DACx_CO:LPEN} = 0$), DAC set to 0x800, temperature range is across the full range of the device

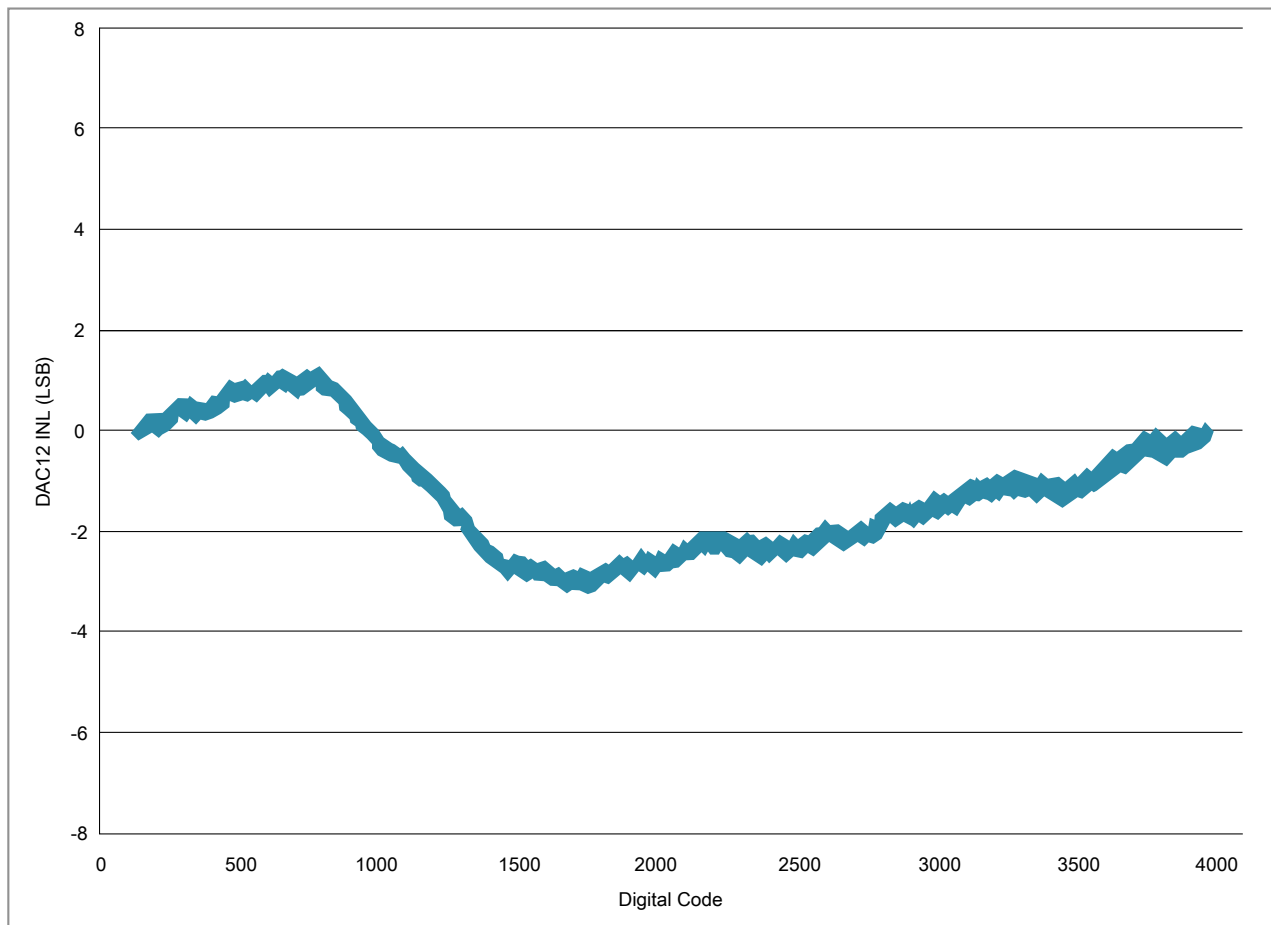

Figure 20. Typical INL error vs. digital code

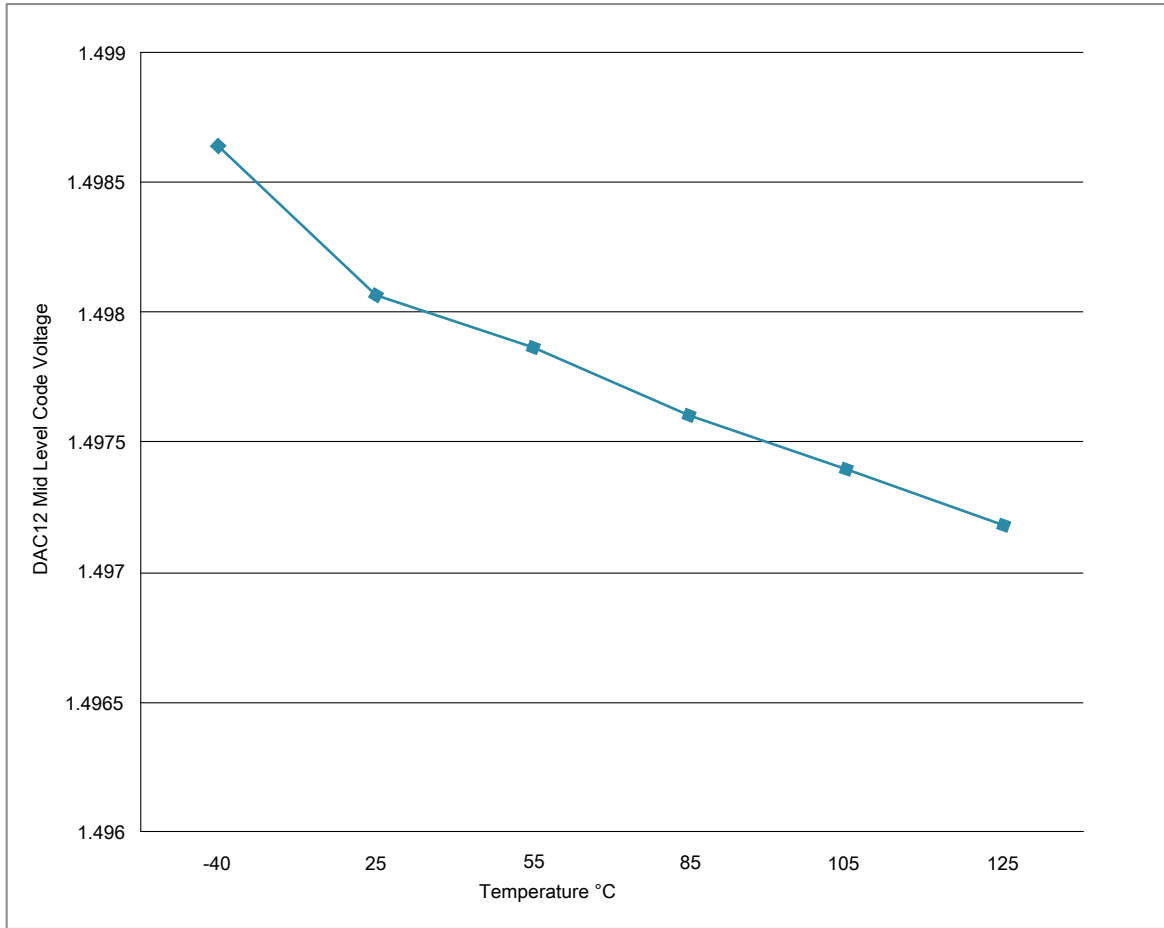

Figure 21. Offset at half scale vs. temperature

3.6.4 Voltage reference electrical specifications

Table 32. VREF full-range operating requirements

| Symbol | Description | Min. | Max. | Unit | Notes |
|------------------|-------------------------|---|------|------|-------|
| V _{DDA} | Supply voltage | 1.71 | 3.6 | V | — |
| T _A | Temperature | Operating temperature range of the device | | °C | — |
| C _L | Output load capacitance | 100 | | nF | 1, 2 |

1. C_L must be connected to VREF_OUT if the VREF_OUT functionality is being used for either an internal or external reference.
2. The load capacitance should not exceed +/-25% of the nominal specified C_L value over the operating temperature range of the device.

Table 33. VREF full-range operating behaviors

| Symbol | Description | Min. | Typ. | Max. | Unit | Notes |
|-------------------|--|--------|-------|--------|---------|-------|
| V_{out} | Voltage reference output with factory trim at nominal V_{DDA} and temperature=25C | 1.1915 | 1.195 | 1.1977 | V | 1 |
| V_{out} | Voltage reference output — factory trim | 1.1584 | — | 1.2376 | V | 1 |
| V_{out} | Voltage reference output — user trim | 1.193 | — | 1.197 | V | 1 |
| V_{step} | Voltage reference trim step | — | 0.5 | — | mV | 1 |
| V_{tdrift} | Temperature drift ($V_{max} - V_{min}$ across the full temperature range) | — | — | 80 | mV | 1 |
| I_{bg} | Bandgap only current | — | — | 80 | μA | 1 |
| ΔV_{LOAD} | Load regulation <ul style="list-style-type: none"> current = ± 1.0 mA | — | 200 | — | μV | 1, 2 |
| T_{stup} | Buffer startup time | — | — | 100 | μs | — |
| V_{vdrift} | Voltage drift ($V_{max} - V_{min}$ across the full voltage range) | — | 2 | — | mV | 1 |

1. See the chip's Reference Manual for the appropriate settings of the VREF Status and Control register.
2. Load regulation voltage is the difference between the VREF_OUT voltage with no load vs. voltage with defined load

Table 34. VREF limited-range operating requirements

| Symbol | Description | Min. | Max. | Unit | Notes |
|--------|-------------|------|------|-------------|-------|
| T_A | Temperature | 0 | 50 | $^{\circ}C$ | — |

Table 35. VREF limited-range operating behaviors

| Symbol | Description | Min. | Max. | Unit | Notes |
|-----------|--|-------|-------|------|-------|
| V_{out} | Voltage reference output with factory trim | 1.173 | 1.225 | V | — |

3.7 Timers

See [General switching specifications](#).

3.8 Communication interfaces

3.8.1 USB electrical specifications

The USB electricals for the USB On-the-Go module conform to the standards documented by the Universal Serial Bus Implementers Forum. For the most up-to-date standards, visit usb.org.

NOTE

The MCGFLLCLK does not meet the USB jitter specifications for certification.

3.8.2 USB DCD electrical specifications

Table 36. USB0 DCD electrical specifications

| Symbol | Description | Min. | Typ. | Max. | Unit |
|----------------------|--|-------|------|------|------------|
| V _{DP_SRC} | USB_DP source voltage (up to 250 μ A) | 0.5 | — | 0.7 | V |
| V _{LGC} | Threshold voltage for logic high | 0.8 | — | 2.0 | V |
| I _{DP_SRC} | USB_DP source current | 7 | 10 | 13 | μ A |
| I _{DM_SINK} | USB_DM sink current | 50 | 100 | 150 | μ A |
| R _{DM_DWN} | D- pulldown resistance for data pin contact detect | 14.25 | — | 24.8 | k Ω |
| V _{DAT_REF} | Data detect voltage | 0.25 | 0.33 | 0.4 | V |

3.8.3 USB VREG electrical specifications

Table 37. USB VREG electrical specifications

| Symbol | Description | Min. | Typ. ¹ | Max. | Unit | Notes |
|-----------------------|---|------|-------------------|------|---------|-------|
| V _{REGIN} | Input supply voltage | 2.7 | — | 5.5 | V | |
| I _{DDon} | Quiescent current — Run mode, load current equal zero, input supply (V _{REGIN}) > 3.6 V | — | 125 | 186 | μ A | |
| I _{DDstby} | Quiescent current — Standby mode, load current equal zero | — | 1.1 | 10 | μ A | |
| I _{DDoff} | Quiescent current — Shutdown mode | — | 650 | — | nA | |
| | | — | — | 4 | μ A | |
| I _{LOADrun} | Maximum load current — Run mode | — | — | 120 | mA | |
| I _{LOADstby} | Maximum load current — Standby mode | — | — | 1 | mA | |
| V _{Reg33out} | Regulator output voltage — Input supply (V _{REGIN}) > 3.6 V | | | | | |

Table continues on the next page...

Table 37. USB VREG electrical specifications (continued)

| Symbol | Description | Min. | Typ. ¹ | Max. | Unit | Notes |
|-----------------------|--|----------|-------------------|------------|--------|-------|
| | <ul style="list-style-type: none"> Run mode Standby mode | 3 2.1 | 3.3 2.8 | 3.6 3.6 | V V | |
| V _{Reg33out} | Regulator output voltage — Input supply (VREGIN) < 3.6 V, pass-through mode | 2.1 | — | 3.6 | V | 2 |
| C _{OUT} | External output capacitor | 1.76 | 2.2 | 8.16 | μF | |
| ESR | External output capacitor equivalent series resistance | 1 | — | 100 | mΩ | |
| I _{LIM} | Short circuit current | — | 290 | — | mA | |

1. Typical values assume VREGIN = 5.0 V, Temp = 25 °C unless otherwise stated.
2. Operating in pass-through mode: regulator output voltage equal to the input voltage minus a drop proportional to I_{Load}.

3.8.4 CAN switching specifications

See [General switching specifications](#).

3.8.5 DSPI switching specifications (limited voltage range)

The DMA Serial Peripheral Interface (DSPI) provides a synchronous serial bus with master and slave operations. Many of the transfer attributes are programmable. The tables below provide DSPI timing characteristics for classic SPI timing modes. Refer to the DSPI chapter of the Reference Manual for information on the modified transfer formats used for communicating with slower peripheral devices.

Table 38. Master mode DSPI timing (limited voltage range)

| Num | Description | Min. | Max. | Unit | Notes |
|-----|---|----------------------------|---------------------------|------|-------|
| | Operating voltage | 2.7 | 3.6 | V | |
| | Frequency of operation | — | 30 | MHz | |
| DS1 | DSPI_SCK output cycle time | 2 x t _{BUS} | — | ns | |
| DS2 | DSPI_SCK output high/low time | (t _{SCK} /2) - 2 | (t _{SCK} /2) + 2 | ns | |
| DS3 | DSPI_PCS _n valid to DSPI_SCK delay | (t _{BUS} x 2) - 2 | — | ns | 1 |
| DS4 | DSPI_SCK to DSPI_PCS _n invalid delay | (t _{BUS} x 2) - 2 | — | ns | 2 |
| DS5 | DSPI_SCK to DSPI_SOUT valid | — | 8.5 | ns | |
| DS6 | DSPI_SCK to DSPI_SOUT invalid | -2 | — | ns | |

Table continues on the next page...

Table 38. Master mode DSPI timing (limited voltage range) (continued)

| Num | Description | Min. | Max. | Unit | Notes |
|-----|----------------------------------|------|------|------|-------|
| DS7 | DSPI_SIN to DSPI_SCK input setup | 15 | — | ns | |
| DS8 | DSPI_SCK to DSPI_SIN input hold | 0 | — | ns | |

1. The delay is programmable in SPIx_CTARn[PSSCK] and SPIx_CTARn[CSSCK].
2. The delay is programmable in SPIx_CTARn[PASC] and SPIx_CTARn[ASC].

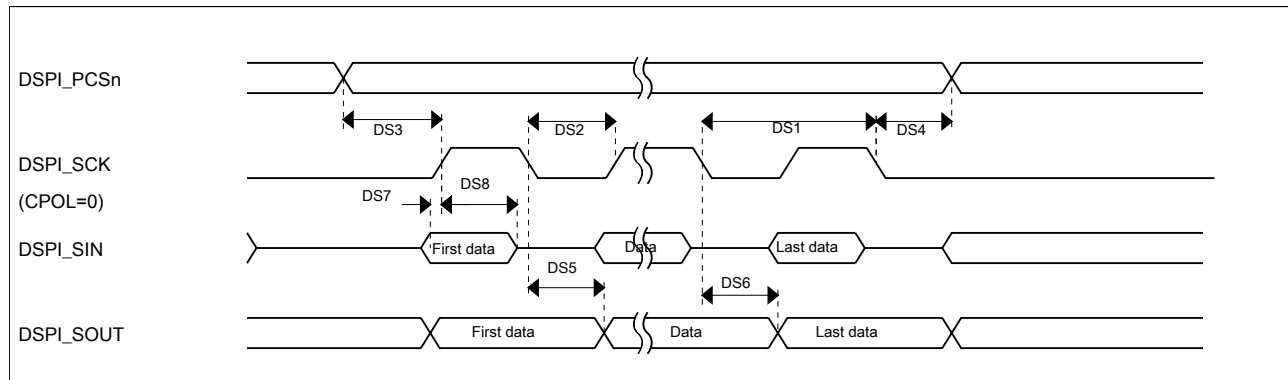
Figure 22. DSPI classic SPI timing — master mode
Table 39. Slave mode DSPI timing (limited voltage range)

| Num | Description | Min. | Max. | Unit |
|------|--|--------------------|-------------------|------|
| | Operating voltage | 2.7 | 3.6 | V |
| | Frequency of operation | | 15 | MHz |
| DS9 | DSPI_SCK input cycle time | $4 \times t_{BUS}$ | — | ns |
| DS10 | DSPI_SCK input high/low time | $(t_{SCK}/2) - 2$ | $(t_{SCK}/2) + 2$ | ns |
| DS11 | DSPI_SCK to DSPI_SOUT valid | — | 17.4 | ns |
| DS12 | DSPI_SCK to DSPI_SOUT invalid | 0 | — | ns |
| DS13 | DSPI_SIN to DSPI_SCK input setup | 2 | — | ns |
| DS14 | DSPI_SCK to DSPI_SIN input hold | 7 | — | ns |
| DS15 | $\overline{DSPI_SS}$ active to DSPI_SOUT driven | — | 16 | ns |
| DS16 | $\overline{DSPI_SS}$ inactive to DSPI_SOUT not driven | — | 16 | ns |

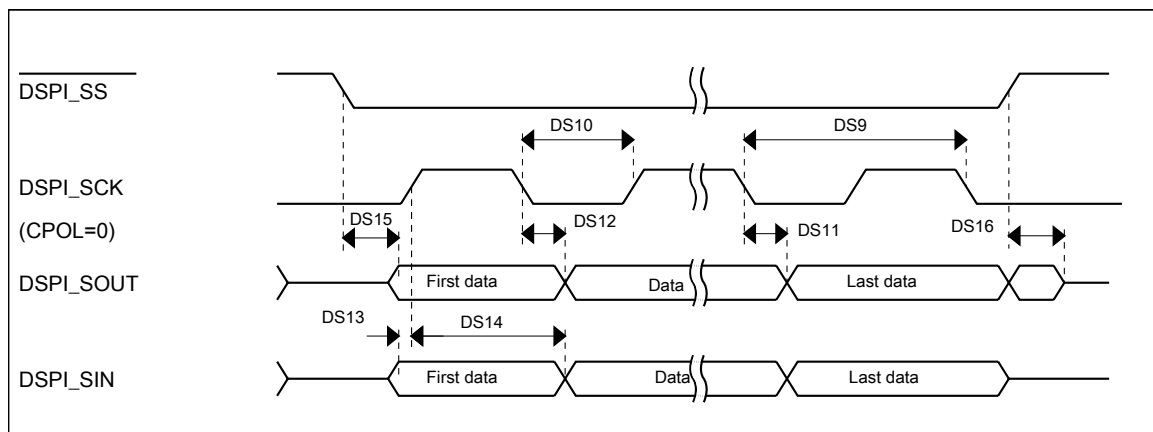

Figure 23. DSPI classic SPI timing — slave mode

3.8.6 DSPI switching specifications (full voltage range)

The DMA Serial Peripheral Interface (DSPI) provides a synchronous serial bus with master and slave operations. Many of the transfer attributes are programmable. The tables below provides DSPI timing characteristics for classic SPI timing modes. Refer to the DSPI chapter of the Reference Manual for information on the modified transfer formats used for communicating with slower peripheral devices.

Table 40. Master mode DSPI timing (full voltage range)

| Num | Description | Min. | Max. | Unit | Notes |
|-----|-------------------------------------|--------------------------|-------------------|------|-------|
| | Operating voltage | 1.71 | 3.6 | V | 1 |
| | Frequency of operation | — | 15 | MHz | |
| DS1 | DSPI_SCK output cycle time | $4 \times t_{BUS}$ | — | ns | |
| DS2 | DSPI_SCK output high/low time | $(t_{SCK}/2) - 4$ | $(t_{SCK}/2) + 4$ | ns | |
| DS3 | DSPI_PCSn valid to DSPI_SCK delay | $(t_{BUS} \times 2) - 4$ | — | ns | 2 |
| DS4 | DSPI_SCK to DSPI_PCSn invalid delay | $(t_{BUS} \times 2) - 4$ | — | ns | 3 |
| DS5 | DSPI_SCK to DSPI_SOUT valid | — | 10 | ns | |
| DS6 | DSPI_SCK to DSPI_SOUT invalid | -4.5 | — | ns | |
| DS7 | DSPI_SIN to DSPI_SCK input setup | 20.5 | — | ns | |
| DS8 | DSPI_SCK to DSPI_SIN input hold | 0 | — | ns | |

1. The DSPI module can operate across the entire operating voltage for the processor, but to run across the full voltage range the maximum frequency of operation is reduced.
2. The delay is programmable in SPIx_CTARn[PSSCK] and SPIx_CTARn[CSSCK].
3. The delay is programmable in SPIx_CTARn[PASC] and SPIx_CTARn[ASC].

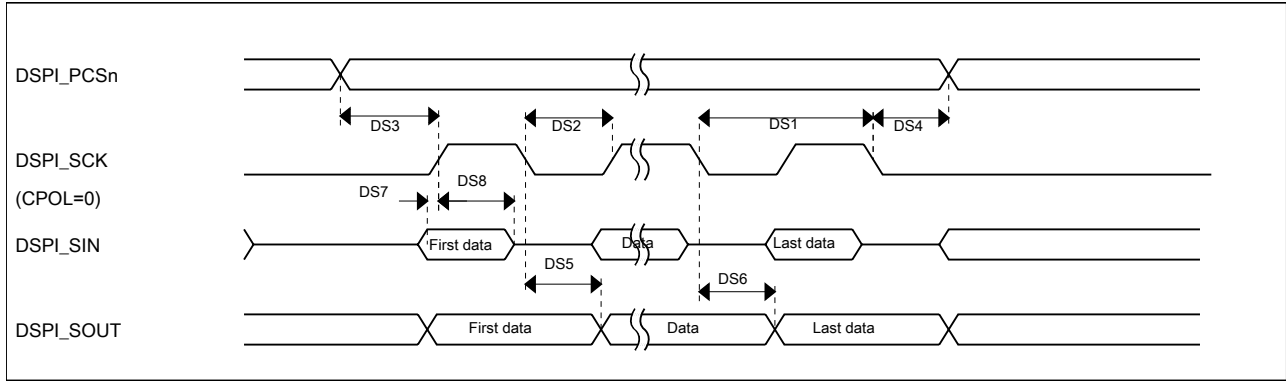

Figure 24. DSPI classic SPI timing — master mode

Table 41. Slave mode DSPI timing (full voltage range)

| Num | Description | Min. | Max. | Unit |
|------|--|--------------------|-------------------|------|
| | Operating voltage | 1.71 | 3.6 | V |
| | Frequency of operation | — | 7.5 | MHz |
| DS9 | DSPI_SCK input cycle time | $8 \times t_{BUS}$ | — | ns |
| DS10 | DSPI_SCK input high/low time | $(t_{SCK}/2) - 4$ | $(t_{SCK}/2) + 4$ | ns |
| DS11 | DSPI_SCK to DSPI_SOUT valid | — | 20 | ns |
| DS12 | DSPI_SCK to DSPI_SOUT invalid | 0 | — | ns |
| DS13 | DSPI_SIN to DSPI_SCK input setup | 2 | — | ns |
| DS14 | DSPI_SCK to DSPI_SIN input hold | 7 | — | ns |
| DS15 | $\overline{DSPI_SS}$ active to DSPI_SOUT driven | — | 19 | ns |
| DS16 | $\overline{DSPI_SS}$ inactive to DSPI_SOUT not driven | — | 19 | ns |

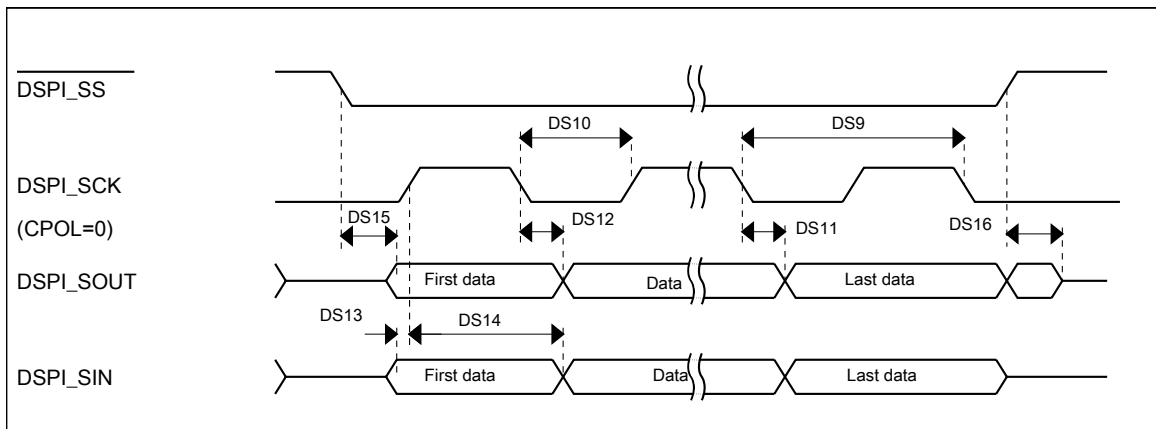

Figure 25. DSPI classic SPI timing — slave mode

3.8.7 I²C switching specifications

See [General switching specifications](#).

3.8.8 UART switching specifications

See [General switching specifications](#).

3.8.9 SDHC specifications

The following timing specs are defined at the chip I/O pin and must be translated appropriately to arrive at timing specs/constraints for the physical interface. The following timing specifications assume a load of 50 pF.

Table 42. SDHC switching specifications

| Num | Symbol | Description | Min. | Max. | Unit |
|---|------------------|---|------|-------|------|
| | | Operating voltage | 1.71 | 3.6 | V |
| Card input clock | | | | | |
| SD1 | f _{pp} | Clock frequency (low speed) | 0 | 400 | kHz |
| | f _{pp} | Clock frequency (SD\SDIO full speed\high speed) | 0 | 25\50 | MHz |
| | f _{pp} | Clock frequency (MMC full speed\high speed) | 0 | 20\50 | MHz |
| | f _{OD} | Clock frequency (identification mode) | 0 | 400 | kHz |
| SD2 | t _{WL} | Clock low time | 7 | — | ns |
| SD3 | t _{WH} | Clock high time | 7 | — | ns |
| SD4 | t _{TLH} | Clock rise time | — | 3 | ns |
| SD5 | t _{THL} | Clock fall time | — | 3 | ns |
| SDHC output / card inputs SDHC_CMD, SDHC_DAT (reference to SDHC_CLK) | | | | | |
| SD6 | t _{OD} | SDHC output delay (output valid) | -5 | 8.3 | ns |
| SDHC input / card inputs SDHC_CMD, SDHC_DAT (reference to SDHC_CLK) | | | | | |
| SD7 | t _{ISU} | SDHC input setup time | 5 | — | ns |
| SD8 | t _{IH} | SDHC input hold time | 0 | — | ns |

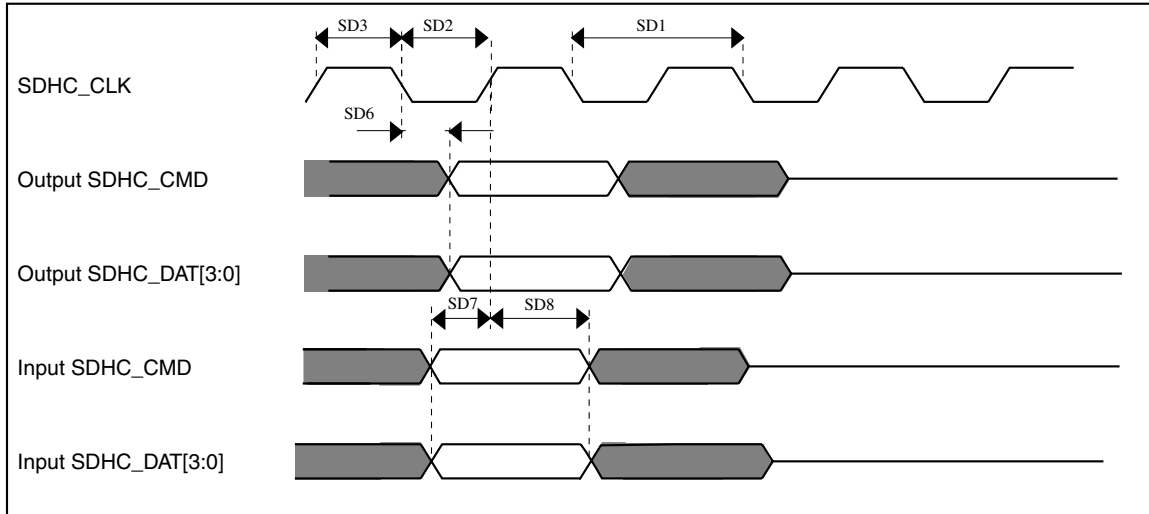
Figure 26. SDHC timing

3.8.10 I²S switching specifications

This section provides the AC timings for the I²S in master (clocks driven) and slave modes (clocks input). All timings are given for non-inverted serial clock polarity (TCR[TSCKP] = 0, RCR[RSCKP] = 0) and a non-inverted frame sync (TCR[TFSI] = 0, RCR[RFSI] = 0). If the polarity of the clock and/or the frame sync have been inverted, all the timings remain valid by inverting the clock signal (I2S_BCLK) and/or the frame sync (I2S_FS) shown in the figures below.

Table 43. I²S master mode timing

| Num | Description | Min. | Max. | Unit |
|-----|--|------|------|-------------|
| | Operating voltage | 2.7 | 3.6 | V |
| S1 | I2S_MCLK cycle time | 40 | — | ns |
| S2 | I2S_MCLK pulse width high/low | 45% | 55% | MCLK period |
| S3 | I2S_BCLK cycle time | 80 | — | ns |
| S4 | I2S_BCLK pulse width high/low | 45% | 55% | BCLK period |
| S5 | I2S_BCLK to I2S_FS output valid | — | 15 | ns |
| S6 | I2S_BCLK to I2S_FS output invalid | 0 | — | ns |
| S7 | I2S_BCLK to I2S_TXD valid | — | 15 | ns |
| S8 | I2S_BCLK to I2S_TXD invalid | 0 | — | ns |
| S9 | I2S_RXD/I2S_FS input setup before I2S_BCLK | 15 | — | ns |
| S10 | I2S_RXD/I2S_FS input hold after I2S_BCLK | 0 | — | ns |

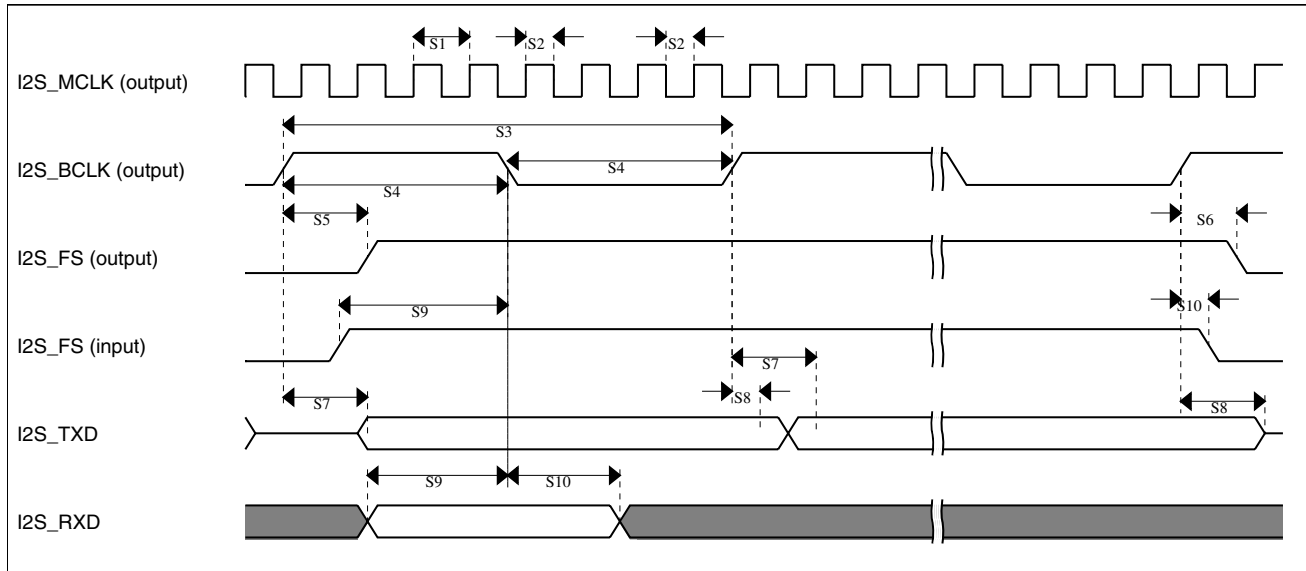

Figure 27. I²S timing — master mode

Table 44. I²S slave mode timing

| Num | Description | Min. | Max. | Unit |
|-----|--|------|------|-------------|
| | Operating voltage | 2.7 | 3.6 | V |
| S11 | I2S_BCLK cycle time (input) | 80 | — | ns |
| S12 | I2S_BCLK pulse width high/low (input) | 45% | 55% | MCLK period |
| S13 | I2S_FS input setup before I2S_BCLK | 4.5 | — | ns |
| S14 | I2S_FS input hold after I2S_BCLK | 2 | — | ns |
| S15 | I2S_BCLK to I2S_TXD/I2S_FS output valid | — | 18 | ns |
| S16 | I2S_BCLK to I2S_TXD/I2S_FS output invalid | 0 | — | ns |
| S17 | I2S_RXD setup before I2S_BCLK | 4.5 | — | ns |
| S18 | I2S_RXD hold after I2S_BCLK | 2 | — | ns |
| S19 | I2S_TX_FS input assertion to I2S_TXD output valid ¹ | | 21 | ns |

1. Applies to first bit in each frame and only if the TCR4[FSE] bit is clear

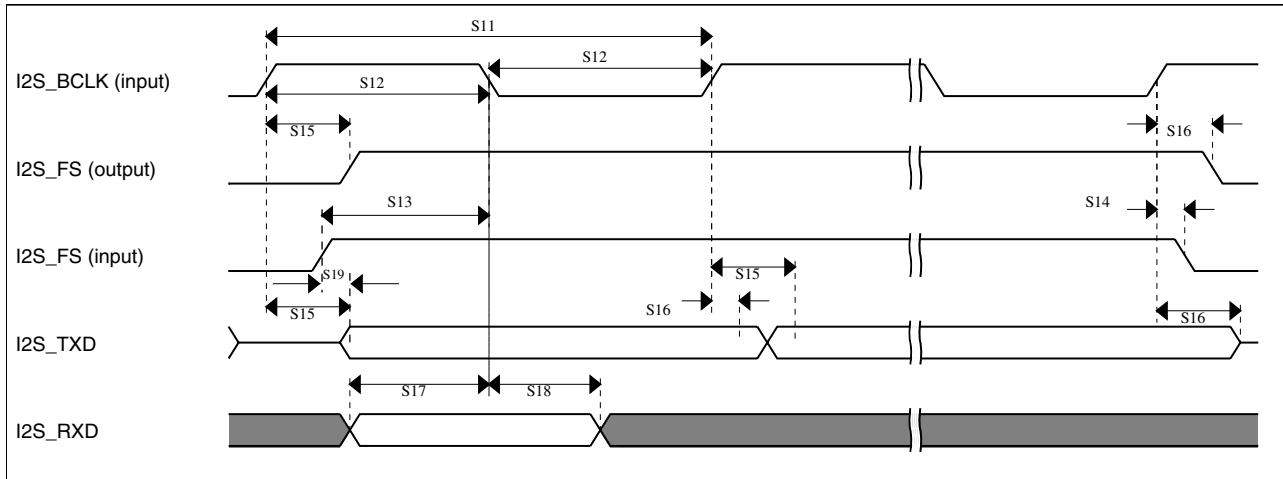

Figure 28. I²S timing — slave modes

3.8.10.1 Normal Run, Wait and Stop mode performance over the full operating voltage range

This section provides the operating performance over the full operating voltage for the device in Normal Run, Wait and Stop modes.

Table 45. I2S/SAI master mode timing

| Num. | Characteristic | Min. | Max. | Unit |
|------|---|------|------|-------------|
| | Operating voltage | 1.71 | 3.6 | V |
| S1 | I2S_MCLK cycle time | 40 | — | ns |
| S2 | I2S_MCLK (as an input) pulse width high/low | 45% | 55% | MCLK period |
| S3 | I2S_TX_BCLK/I2S_RX_BCLK cycle time (output) | 80 | — | ns |
| S4 | I2S_TX_BCLK/I2S_RX_BCLK pulse width high/low | 45% | 55% | BCLK period |
| S5 | I2S_TX_BCLK/I2S_RX_BCLK to I2S_TX_FS/ I2S_RX_FS output valid | — | 15 | ns |
| S6 | I2S_TX_BCLK/I2S_RX_BCLK to I2S_TX_FS/ I2S_RX_FS output invalid | -1 | — | ns |
| S7 | I2S_TX_BCLK to I2S_TXD valid | — | 15 | ns |
| S8 | I2S_TX_BCLK to I2S_TXD invalid | 0 | — | ns |
| S9 | I2S_RXD/I2S_RX_FS input setup before I2S_RX_BCLK | 20.5 | — | ns |
| S10 | I2S_RXD/I2S_RX_FS input hold after I2S_RX_BCLK | 0 | — | ns |

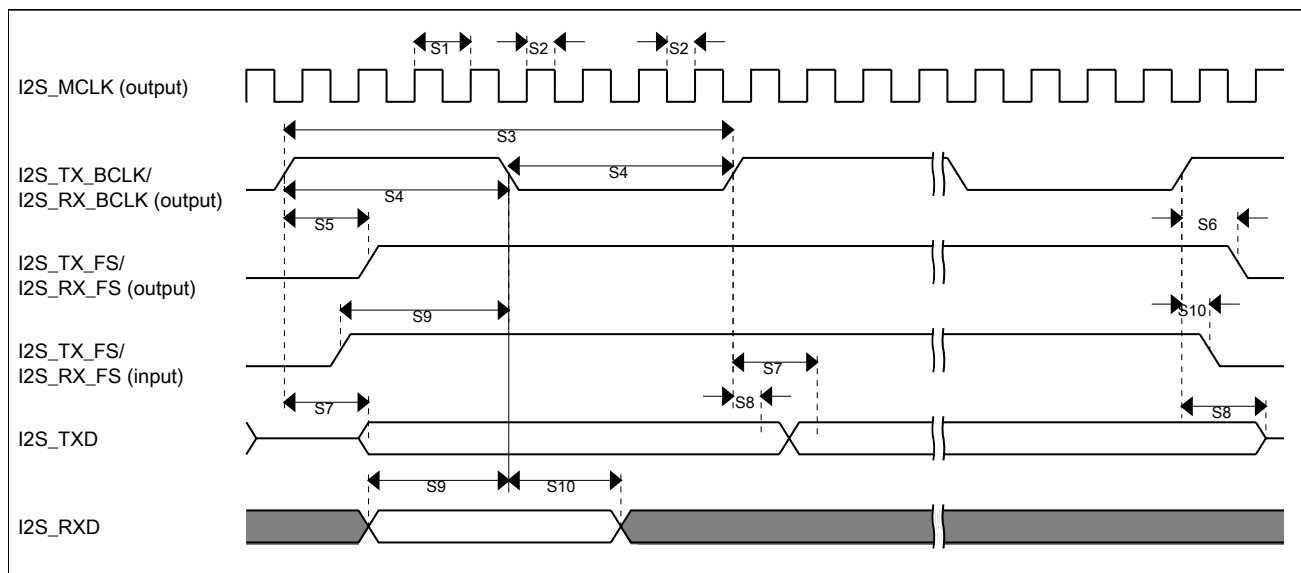

Figure 29. I2S/SAI timing — master modes

Table 46. I2S/SAI slave mode timing

| Num. | Characteristic | Min. | Max. | Unit |
|------|--|------|------|-------------|
| | Operating voltage | 1.71 | 3.6 | V |
| S11 | I2S_TX_BCLK/I2S_RX_BCLK cycle time (input) | 80 | — | ns |
| S12 | I2S_TX_BCLK/I2S_RX_BCLK pulse width high/low (input) | 45% | 55% | MCLK period |
| S13 | I2S_TX_FS/I2S_RX_FS input setup before I2S_TX_BCLK/I2S_RX_BCLK | 5.8 | — | ns |
| S14 | I2S_TX_FS/I2S_RX_FS input hold after I2S_TX_BCLK/I2S_RX_BCLK | 2 | — | ns |
| S15 | I2S_TX_BCLK to I2S_TXD/I2S_TX_FS output valid | — | 23.5 | ns |
| S16 | I2S_TX_BCLK to I2S_TXD/I2S_TX_FS output invalid | 0 | — | ns |
| S17 | I2S_RXD setup before I2S_RX_BCLK | 5.8 | — | ns |
| S18 | I2S_RXD hold after I2S_RX_BCLK | 2 | — | ns |
| S19 | I2S_TX_FS input assertion to I2S_TXD output valid ¹ | — | 25 | ns |

1. Applies to first bit in each frame and only if the TCR4[FSE] bit is clear

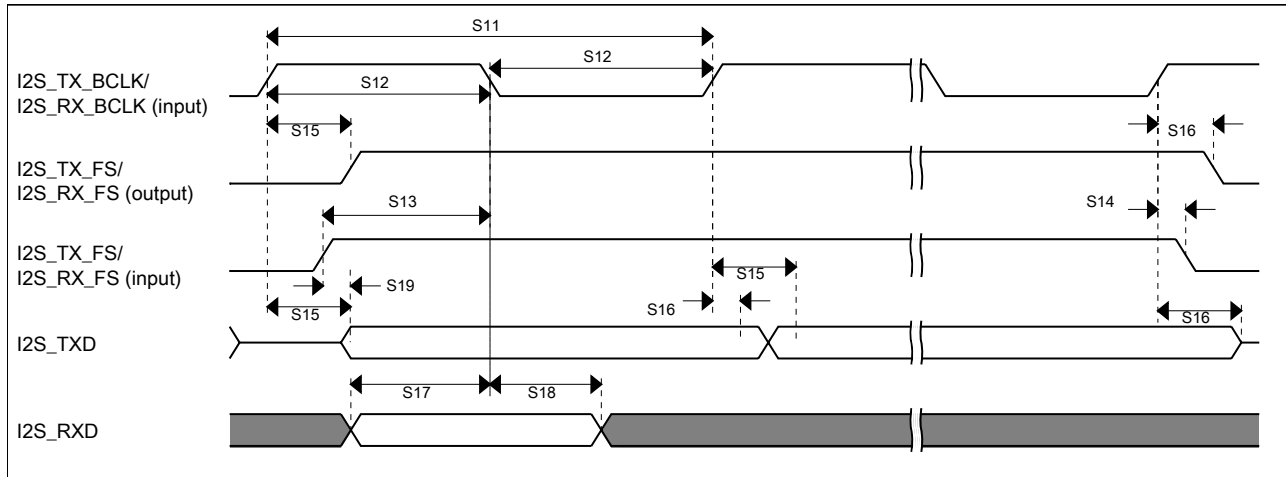

Figure 30. I2S/SAI timing — slave modes

3.8.10.2 VLPR, VLPW, and VLPS mode performance over the full operating voltage range

This section provides the operating performance over the full operating voltage for the device in VLPR, VLPW, and VLPS modes.

Table 47. I2S/SAI master mode timing in VLPR, VLPW, and VLPS modes (full voltage range)

| Num. | Characteristic | Min. | Max. | Unit |
|------|---|------|------|-------------|
| | Operating voltage | 1.71 | 3.6 | V |
| S1 | I2S_MCLK cycle time | 62.5 | — | ns |
| S2 | I2S_MCLK pulse width high/low | 45% | 55% | MCLK period |
| S3 | I2S_TX_BCLK/I2S_RX_BCLK cycle time (output) | 250 | — | ns |
| S4 | I2S_TX_BCLK/I2S_RX_BCLK pulse width high/low | 45% | 55% | BCLK period |
| S5 | I2S_TX_BCLK/I2S_RX_BCLK to I2S_TX_FS/ I2S_RX_FS output valid | — | 45 | ns |
| S6 | I2S_TX_BCLK/I2S_RX_BCLK to I2S_TX_FS/ I2S_RX_FS output invalid | 0 | — | ns |
| S7 | I2S_TX_BCLK to I2S_TXD valid | — | 45 | ns |
| S8 | I2S_TX_BCLK to I2S_TXD invalid | | — | ns |
| S9 | I2S_RXD/I2S_RX_FS input setup before I2S_RX_BCLK | | — | ns |
| S10 | I2S_RXD/I2S_RX_FS input hold after I2S_RX_BCLK | 0 | — | ns |

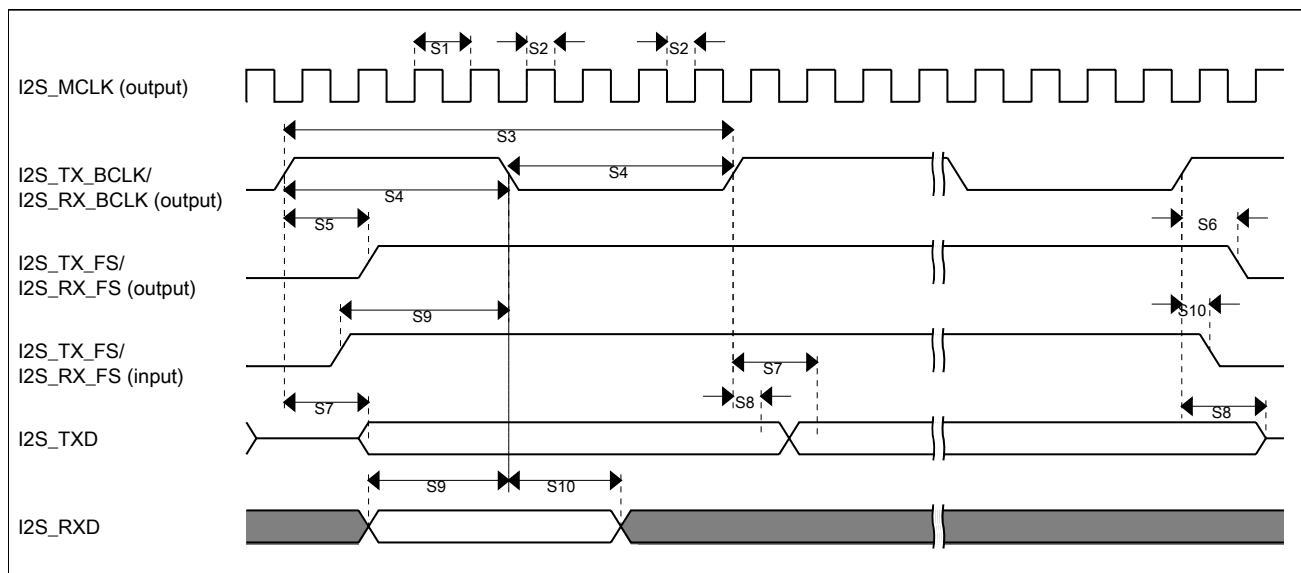

Figure 31. I2S/SAI timing — master modes

Table 48. I2S/SAI slave mode timing in VLPR, VLPW, and VLPS modes (full voltage range)

| Num. | Characteristic | Min. | Max. | Unit |
|------|--|------|------|-------------|
| | Operating voltage | 1.71 | 3.6 | V |
| S11 | I2S_TX_BCLK/I2S_RX_BCLK cycle time (input) | 250 | — | ns |
| S12 | I2S_TX_BCLK/I2S_RX_BCLK pulse width high/low (input) | 45% | 55% | MCLK period |
| S13 | I2S_TX_FS/I2S_RX_FS input setup before I2S_TX_BCLK/I2S_RX_BCLK | 30 | — | ns |
| S14 | I2S_TX_FS/I2S_RX_FS input hold after I2S_TX_BCLK/I2S_RX_BCLK | | — | ns |
| S15 | I2S_TX_BCLK to I2S_TXD/I2S_TX_FS output valid | — | | ns |
| S16 | I2S_TX_BCLK to I2S_TXD/I2S_TX_FS output invalid | 0 | — | ns |
| S17 | I2S_RXD setup before I2S_RX_BCLK | 30 | — | ns |
| S18 | I2S_RXD hold after I2S_RX_BCLK | | — | ns |
| S19 | I2S_TX_FS input assertion to I2S_TXD output valid ¹ | — | 72 | ns |

1. Applies to first bit in each frame and only if the TCR4[FSE] bit is clear

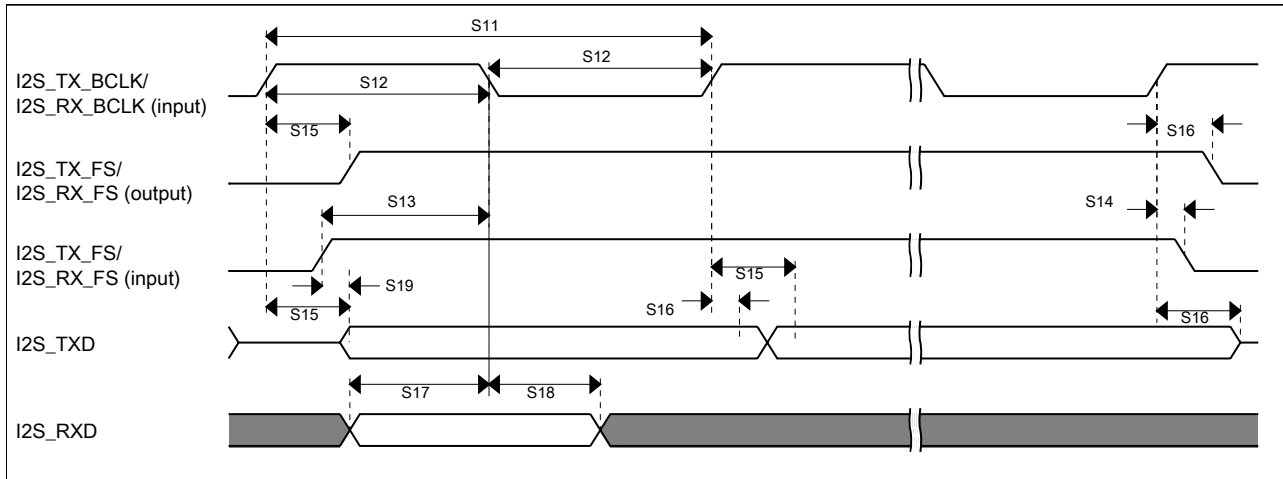

Figure 32. I2S/SAI timing — slave modes

3.8.10.3 Ordering parts

3.8.10.3.1 Determining valid orderable parts

Valid orderable part numbers are provided on the web. To determine the orderable part numbers for this device, go to freescale.com and perform a part number search for the following device numbers: PK21 and MK21

3.8.10.4 Part identification

3.8.10.4.1 Description

Part numbers for the chip have fields that identify the specific part. You can use the values of these fields to determine the specific part you have received.

3.8.10.4.2 Format

Part numbers for this device have the following format:

Q K## A M FFF R T PP CC N

3.8.10.4.3 Fields

This table lists the possible values for each field in the part number (not all combinations are valid):

Peripheral operating requirements and behaviors

| Field | Description | Values |
|-------|-----------------------------|---|
| Q | Qualification status | <ul style="list-style-type: none"> M = Fully qualified, general market flow P = Prequalification |
| K## | Kinetis family | <ul style="list-style-type: none"> K21 |
| A | Key attribute | <ul style="list-style-type: none"> D = Cortex-M4 w/ DSP F = Cortex-M4 w/ DSP and FPU |
| M | Flash memory type | <ul style="list-style-type: none"> N = Program flash only X = Program flash and FlexMemory |
| FFF | Program flash memory size | <ul style="list-style-type: none"> 32 = 32 KB 64 = 64 KB 128 = 128 KB 256 = 256 KB 512 = 512 KB 1M0 = 1 MB 2M0 = 2 MB |
| R | Silicon revision | <ul style="list-style-type: none"> Z = Initial (Blank) = Main A = Revision after main |
| T | Temperature range (°C) | <ul style="list-style-type: none"> V = -40 to 105 C = -40 to 85 |
| PP | Package identifier | <ul style="list-style-type: none"> FM = 32 QFN (5 mm x 5 mm) FT = 48 QFN (7 mm x 7 mm) LF = 48 LQFP (7 mm x 7 mm) LH = 64 LQFP (10 mm x 10 mm) MP = 64 MAPBGA (5 mm x 5 mm) LK = 80 LQFP (12 mm x 12 mm) LL = 100 LQFP (14 mm x 14 mm) MC = 121 MAPBGA (8 mm x 8 mm) DC = 121 XFBGA (8 mm x 8 mm x 0.5 mm) LQ = 144 LQFP (20 mm x 20 mm) MD = 144 MAPBGA (13 mm x 13 mm) |
| CC | Maximum CPU frequency (MHz) | <ul style="list-style-type: none"> 5 = 50 MHz 7 = 72 MHz 10 = 100 MHz 12 = 120 MHz 15 = 150 MHz 16 = 168 MHz 18 = 180 MHz |
| N | Packaging type | <ul style="list-style-type: none"> R = Tape and reel (Blank) = Trays |

3.8.10.4.4 Example

This is an example part number:

MK21FN1M0VMD10

3.8.10.4.5 Small package marking

In an effort to save space, small package devices use special marking on the chip. These markings have the following format:

Q ## C F T PP

This table lists the possible values for each field in the part number for small packages (not all combinations are valid):

| Field | Description | Values |
|-------|----------------------------|--|
| Q | Qualification status | <ul style="list-style-type: none"> M = Fully qualified, general market flow P = Prequalification |
| ## | Kinetis family | <ul style="list-style-type: none"> 2# = K21/K22 |
| C | Speed | <ul style="list-style-type: none"> H = 120 MHz |
| F | Flash memory configuration | <ul style="list-style-type: none"> K = 512 KB + Flex 1 = 1 MB |
| T | Temperature range (°C) | <ul style="list-style-type: none"> V = -40 to 105 |
| PP | Package identifier | <ul style="list-style-type: none"> LL = 100 LQFP MC = 121 MAPBGA LQ = 144 LQFP MD = 144 MAPBGA DC = 121 XFBGA |

This tables lists some examples of small package marking along with the original part numbers:

| Original part number | Alternate part number |
|----------------------|-----------------------|
| MK21FN1M0VLQ12 | M21H1VLQ |
| MK21FX512VMD12 | M21HKVMD |

3.8.10.5 Terminology and guidelines

3.8.10.5.1 Definition: Operating requirement

An *operating requirement* is a specified value or range of values for a technical characteristic that you must guarantee during operation to avoid incorrect operation and possibly decreasing the useful life of the chip.

3.8.10.5.1.1 Example

This is an example of an operating requirement:

Peripheral operating requirements and behaviors

| Symbol | Description | Min. | Max. | Unit |
|-----------------|---------------------------|------|------|------|
| V _{DD} | 1.0 V core supply voltage | 0.9 | 1.1 | V |

3.8.10.5.2 Definition: Operating behavior

Unless otherwise specified, an *operating behavior* is a specified value or range of values for a technical characteristic that are guaranteed during operation if you meet the operating requirements and any other specified conditions.

3.8.10.5.2.1 Example

This is an example of an operating behavior:

| Symbol | Description | Min. | Max. | Unit |
|-----------------|--|------|------|------|
| I _{WP} | Digital I/O weak pullup/pulldown current | 10 | 130 | μA |

3.8.10.5.3 Definition: Attribute

An *attribute* is a specified value or range of values for a technical characteristic that are guaranteed, regardless of whether you meet the operating requirements.

3.8.10.5.3.1 Example

This is an example of an attribute:

| Symbol | Description | Min. | Max. | Unit |
|--------|---------------------------------|------|------|------|
| CIN_D | Input capacitance: digital pins | — | 7 | pF |

3.8.10.5.4 Definition: Rating

A *rating* is a minimum or maximum value of a technical characteristic that, if exceeded, may cause permanent chip failure:

- *Operating ratings* apply during operation of the chip.
- *Handling ratings* apply when the chip is not powered.

3.8.10.5.4.1 Example

This is an example of an operating rating:

| Symbol | Description | Min. | Max. | Unit |
|-----------------|---------------------------|------|------|------|
| V _{DD} | 1.0 V core supply voltage | -0.3 | 1.2 | V |

3.8.10.5.5 Result of exceeding a rating

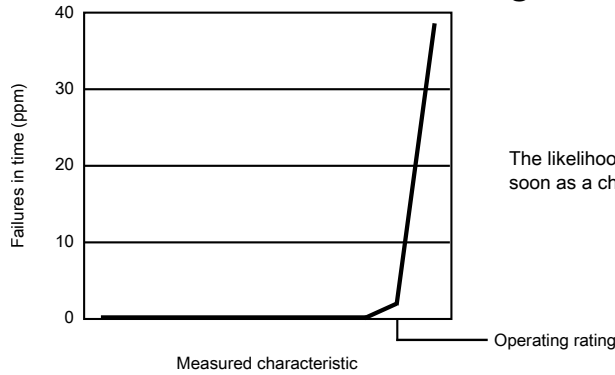

The likelihood of permanent chip failure increases rapidly as soon as a characteristic begins to exceed one of its operating ratings.

3.8.10.5.6 Relationship between ratings and operating requirements

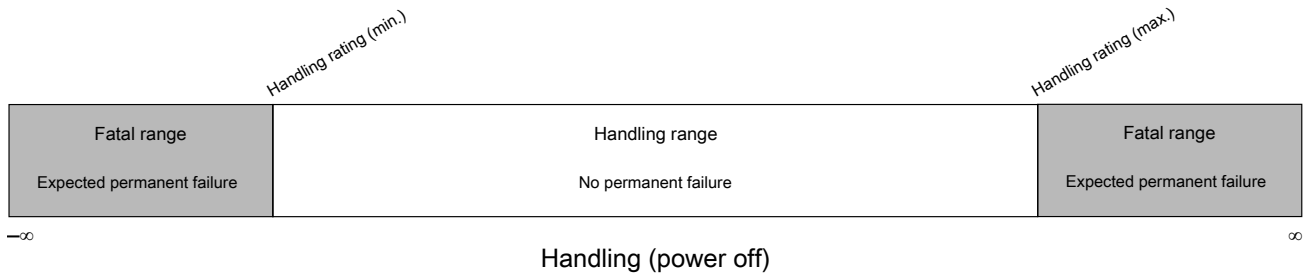
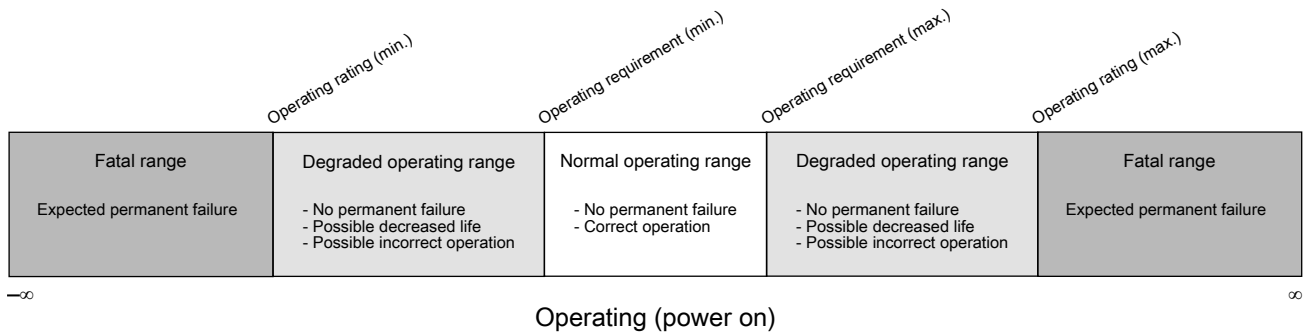

3.8.10.5.7 Guidelines for ratings and operating requirements

Follow these guidelines for ratings and operating requirements:

- Never exceed any of the chip's ratings.

Peripheral operating requirements and behaviors

- During normal operation, don't exceed any of the chip's operating requirements.
- If you must exceed an operating requirement at times other than during normal operation (for example, during power sequencing), limit the duration as much as possible.

3.8.10.5.8 Definition: Typical value

A *typical value* is a specified value for a technical characteristic that:

- Lies within the range of values specified by the operating behavior
- Given the typical manufacturing process, is representative of that characteristic during operation when you meet the typical-value conditions or other specified conditions

Typical values are provided as design guidelines and are neither tested nor guaranteed.

3.8.10.5.8.1 Example 1

This is an example of an operating behavior that includes a typical value:

| Symbol | Description | Min. | Typ. | Max. | Unit |
|----------|--|------|------|------|---------|
| I_{WP} | Digital I/O weak pullup/pulldown current | 10 | 70 | 130 | μA |

3.8.10.5.8.2 Example 2

This is an example of a chart that shows typical values for various voltage and temperature conditions:

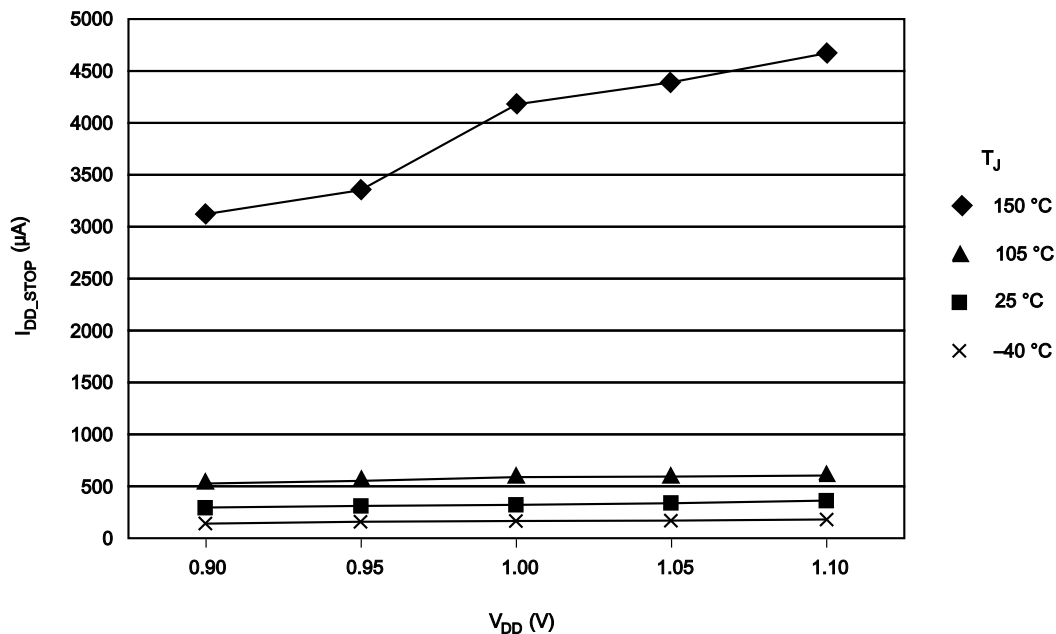

3.8.10.5.9 Typical value conditions

Typical values assume you meet the following conditions (or other conditions as specified):

| Symbol | Description | Value | Unit |
|-----------------|----------------------|-------|------|
| T _A | Ambient temperature | 25 | °C |
| V _{DD} | 3.3 V supply voltage | 3.3 | V |

4 Dimensions

4.1 Obtaining package dimensions

Package dimensions are provided in package drawings.

To find a package drawing, go to freescale.com and perform a keyword search for the drawing's document number:

| If you want the drawing for this package | Then use this document number |
|--|-------------------------------|
| 144-pin LQFP | 98ASS23177W |

Table continues on the next page...

| If you want the drawing for this package | Then use this document number |
|--|-------------------------------|
| 144-pin MAPBGA | 98ASA00222D |
| 169-pin MAPBGA | 98ASA00628D |

5 Pinout

5.1 K21 Signal Multiplexing and Pin Assignments

The following table shows the signals available on each pin and the locations of these pins on the devices supported by this document. The Port Control Module is responsible for selecting which ALT functionality is available on each pin.

NOTE

- The analog input signals ADC0_DP2 and ADC0_DM2 on PTE2 and PTE3 are available only for K21 and K22 devices and are not present on K10 and K20 devices.
- The TRACE signals on PTE0, PTE1, PTE2, PTE3, and PTE4 are available only for K11, K12, K21, and K22 devices and are not present on K10 and K20 devices.
- If the VBAT pin is not used, the VBAT pin should be left floating. Do not connect VBAT pin to VSS.
- The FTM_CLKIN signals on PTB16 and PTB17 are available only for K11, K12, K21, and K22 devices and is not present on K10 and K20 devices. For K22D devices this signal is on ALT7, and for K22F devices, this signal is on ALT4.
- The FTM0_CH2 signal on PTC5/LLWU_P9 is available only for K11, K12, K21, and K22 devices and is not present on K10 and K20 devices.
- The I2C0_SCL signal on PTD2/LLWU_P13 and I2C0_SDA signal on PTD3 are available only for K11, K12, K21, and K22 devices and are not present on K10 and K20 devices.

| 144 MAP BGA | 144 LQFP | Pin Name | Default | ALT0 | ALT1 | ALT2 | ALT3 | ALT4 | ALT5 | ALT6 | ALT7 | EzPort |
|-------------|----------|----------|-----------|-----------|------|-----------|----------|----------|--------------|----------|------------|--------|
| D3 | 1 | PTE0 | ADC1_SE4a | ADC1_SE4a | PTE0 | SPI1_PCS1 | UART1_TX | SDHC0_D1 | TRACE_CLKOUT | I2C1_SDA | RTC_CLKOUT | |

| 144 MAP BGA | 144 LQFP | Pin Name | Default | ALT0 | ALT1 | ALT2 | ALT3 | ALT4 | ALT5 | ALT6 | ALT7 | EzPort |
|-------------|----------|-----------------------|------------------------|------------------------|------------------|-----------|-----------------|------------------|----------|----------|-----------------|--------|
| D2 | 2 | PTE1/ LLWU_P0 | ADC1_SE5a | ADC1_SE5a | PTE1/ LLWU_P0 | SPI1_SOUT | UART1_RX | SDHC0_D0 | TRACE_D3 | I2C1_SCL | SPI1_SIN | |
| D1 | 3 | PTE2/ LLWU_P1 | ADC0_DP2/ ADC1_SE6a | ADC0_DP2/ ADC1_SE6a | PTE2/ LLWU_P1 | SPI1_SCK | UART1_ CTS_b | SDHC0_ DCLK | TRACE_D2 | | | |
| E4 | 4 | PTE3 | ADC0_DM2/ ADC1_SE7a | ADC0_DM2/ ADC1_SE7a | PTE3 | SPI1_SIN | UART1_ RTS_b | SDHC0_ CMD | TRACE_D1 | | SPI1_SOUT | |
| E5 | 5 | VDD | VDD | VDD | | | | | | | | |
| F6 | 6 | VSS | VSS | VSS | | | | | | | | |
| E3 | 7 | PTE4/ LLWU_P2 | DISABLED | | PTE4/ LLWU_P2 | SPI1_PCS0 | UART3_TX | SDHC0_D3 | TRACE_D0 | | | |
| E2 | 8 | PTE5 | DISABLED | | PTE5 | SPI1_PCS2 | UART3_RX | SDHC0_D2 | | FTM3_CH0 | | |
| E1 | 9 | PTE6 | DISABLED | | PTE6 | SPI1_PCS3 | UART3_ CTS_b | I2S0_MCLK | | FTM3_CH1 | USB_SOF_ OUT | |
| F4 | 10 | PTE7 | DISABLED | | PTE7 | | UART3_ RTS_b | I2S0_RXD0 | | FTM3_CH2 | | |
| F3 | 11 | PTE8 | DISABLED | | PTE8 | I2S0_RXD1 | UART5_TX | I2S0_RX_FS | | FTM3_CH3 | | |
| F2 | 12 | PTE9 | DISABLED | | PTE9 | I2S0_TXD1 | UART5_RX | I2S0_RX_ BCLK | | FTM3_CH4 | | |
| F1 | 13 | PTE10 | DISABLED | | PTE10 | | UART5_ CTS_b | I2S0_TXD0 | | FTM3_CH5 | | |
| G4 | 14 | PTE11 | DISABLED | | PTE11 | | UART5_ RTS_b | I2S0_TX_FS | | FTM3_CH6 | | |
| G3 | 15 | PTE12 | DISABLED | | PTE12 | | | I2S0_TX_ BCLK | | FTM3_CH7 | | |
| E6 | 16 | VDD | VDD | VDD | | | | | | | | |
| F7 | 17 | VSS | VSS | VSS | | | | | | | | |
| H3 | 18 | VSS | VSS | VSS | | | | | | | | |
| H1 | 19 | USB0_DP | USB0_DP | USB0_DP | | | | | | | | |
| H2 | 20 | USB0_DM | USB0_DM | USB0_DM | | | | | | | | |
| G1 | 21 | VOUT33 | VOUT33 | VOUT33 | | | | | | | | |
| G2 | 22 | VREGIN | VREGIN | VREGIN | | | | | | | | |
| J1 | 23 | ADC0_DP1 | ADC0_DP1 | ADC0_DP1 | | | | | | | | |
| J2 | 24 | ADC0_DM1 | ADC0_DM1 | ADC0_DM1 | | | | | | | | |
| K1 | 25 | ADC1_DP1 | ADC1_DP1 | ADC1_DP1 | | | | | | | | |
| K2 | 26 | ADC1_DM1 | ADC1_DM1 | ADC1_DM1 | | | | | | | | |
| L1 | 27 | ADC0_DP0/ ADC1_DP3 | ADC0_DP0/ ADC1_DP3 | ADC0_DP0/ ADC1_DP3 | | | | | | | | |
| L2 | 28 | ADC0_DM0/ ADC1_DM3 | ADC0_DM0/ ADC1_DM3 | ADC0_DM0/ ADC1_DM3 | | | | | | | | |
| M1 | 29 | ADC1_DP0/ ADC0_DP3 | ADC1_DP0/ ADC0_DP3 | ADC1_DP0/ ADC0_DP3 | | | | | | | | |
| M2 | 30 | ADC1_DM0/ ADC0_DM3 | ADC1_DM0/ ADC0_DM3 | ADC1_DM0/ ADC0_DM3 | | | | | | | | |

Pinout

| 144 MAP BGA | 144 LQFP | Pin Name | Default | ALT0 | ALT1 | ALT2 | ALT3 | ALT4 | ALT5 | ALT6 | ALT7 | EzPort |
|-------------|----------|--|--|--|-------|------|-----------------|------|------|----------------|-----------|--------|
| H5 | 31 | VDDA | VDDA | VDDA | | | | | | | | |
| G5 | 32 | VREFH | VREFH | VREFH | | | | | | | | |
| G6 | 33 | VREFL | VREFL | VREFL | | | | | | | | |
| H6 | 34 | VSSA | VSSA | VSSA | | | | | | | | |
| K3 | 35 | ADC1_SE16/ CMP2_IN2/ ADC0_SE22 | ADC1_SE16/ CMP2_IN2/ ADC0_SE22 | ADC1_SE16/ CMP2_IN2/ ADC0_SE22 | | | | | | | | |
| J3 | 36 | ADC0_SE16/ CMP1_IN2/ ADC0_SE21 | ADC0_SE16/ CMP1_IN2/ ADC0_SE21 | ADC0_SE16/ CMP1_IN2/ ADC0_SE21 | | | | | | | | |
| M3 | — | VREF_OUT/ CMP1_IN5/ CMP0_IN5/ ADC1_SE18 | VREF_OUT/ CMP1_IN5/ CMP0_IN5/ ADC1_SE18 | VREF_OUT/ CMP1_IN5/ CMP0_IN5/ ADC1_SE18 | | | | | | | | |
| L3 | — | DAC0_OUT/ CMP1_IN3/ ADC0_SE23 | DAC0_OUT/ CMP1_IN3/ ADC0_SE23 | DAC0_OUT/ CMP1_IN3/ ADC0_SE23 | | | | | | | | |
| L4 | — | DAC1_OUT/ CMP0_IN4/ CMP2_IN3/ ADC1_SE23 | DAC1_OUT/ CMP0_IN4/ CMP2_IN3/ ADC1_SE23 | DAC1_OUT/ CMP0_IN4/ CMP2_IN3/ ADC1_SE23 | | | | | | | | |
| L5 | 37 | TAMPER0/ RTC_ WAKEUP_B | TAMPER0/ RTC_ WAKEUP_B | TAMPER0/ RTC_ WAKEUP_B | | | | | | | | |
| K5 | 38 | TAMPER1 | TAMPER1 | TAMPER1 | | | | | | | | |
| K4 | 39 | TAMPER2 | TAMPER2 | TAMPER2 | | | | | | | | |
| J4 | — | TAMPER3 | TAMPER3 | TAMPER3 | | | | | | | | |
| H4 | — | TAMPER4 | TAMPER4 | TAMPER4 | | | | | | | | |
| M4 | — | TAMPER5 | TAMPER5 | TAMPER5 | | | | | | | | |
| M7 | 40 | XTAL32 | XTAL32 | XTAL32 | | | | | | | | |
| M6 | 41 | EXTAL32 | EXTAL32 | EXTAL32 | | | | | | | | |
| L6 | 42 | VBAT | VBAT | VBAT | | | | | | | | |
| — | 43 | VDD | VDD | VDD | | | | | | | | |
| — | 44 | VSS | VSS | VSS | | | | | | | | |
| — | 45 | PTE24 | ADC0_SE17 | ADC0_SE17 | PTE24 | | UART4_TX | | | EWM_OUT_ b | | |
| — | 46 | PTE25 | ADC0_SE18 | ADC0_SE18 | PTE25 | | UART4_RX | | | EWM_IN | | |
| — | 47 | PTE26 | DISABLED | | PTE26 | | UART4_ CTS_b | | | RTC_ CLKOUT | USB_CLKIN | |
| — | 48 | PTE27 | DISABLED | | PTE27 | | UART4_ RTS_b | | | | | |
| — | 49 | PTE28 | DISABLED | | PTE28 | | | | | | | |

| 144 MAP BGA | 144 LQFP | Pin Name | Default | ALT0 | ALT1 | ALT2 | ALT3 | ALT4 | ALT5 | ALT6 | ALT7 | EzPort |
|-------------|----------|-------------------|---------------------------------------|-----------|-------------------|-----------------|-----------------|------------|----------|------------------|----------------------------|----------|
| J5 | 50 | PTA0 | JTAG_TCLK/ SWD_CLK/ EZP_CLK | | PTA0 | UART0_ CTS_b | FTM0_CH5 | | | | JTAG_TCLK/ SWD_CLK | EZP_CLK |
| J6 | 51 | PTA1 | JTAG_TDI/ EZP_DI | | PTA1 | UART0_RX | FTM0_CH6 | | | | JTAG_TDI | EZP_DI |
| K6 | 52 | PTA2 | JTAG_TDO/ TRACE_ SWO/ EZP_DO | | PTA2 | UART0_TX | FTM0_CH7 | | | | JTAG_TDO/ TRACE_ SWO | EZP_DO |
| K7 | 53 | PTA3 | JTAG_TMS/ SWD_DIO | | PTA3 | UART0_ RTS_b | FTM0_CH0 | | | | JTAG_TMS/ SWD_DIO | |
| L7 | 54 | PTA4/ LLWU_P3 | NMI_b/ EZP_CS_b | | PTA4/ LLWU_P3 | | FTM0_CH1 | | | | NMI_b | EZP_CS_b |
| M8 | 55 | PTA5 | DISABLED | | PTA5 | USB_CLKIN | FTM0_CH2 | | CMP2_OUT | I2S0_TX_ BCLK | JTAG_ TRST_b | |
| E7 | 56 | VDD | VDD | VDD | | | | | | | | |
| G7 | 57 | VSS | VSS | VSS | | | | | | | | |
| J7 | 58 | PTA6 | DISABLED | | PTA6 | | FTM0_CH3 | | CLKOUT | | TRACE_ CLKOUT | |
| J8 | 59 | PTA7 | ADC0_SE10 | ADC0_SE10 | PTA7 | | FTM0_CH4 | | | | TRACE_D3 | |
| K8 | 60 | PTA8 | ADC0_SE11 | ADC0_SE11 | PTA8 | | FTM1_CH0 | | | FTM1_QD_ PHA | TRACE_D2 | |
| L8 | 61 | PTA9 | DISABLED | | PTA9 | | FTM1_CH1 | | | FTM1_QD_ PHB | TRACE_D1 | |
| M9 | 62 | PTA10 | DISABLED | | PTA10 | | FTM2_CH0 | | | FTM2_QD_ PHA | TRACE_D0 | |
| L9 | 63 | PTA11 | DISABLED | | PTA11 | | FTM2_CH1 | | I2C2_SDA | FTM2_QD_ PHB | | |
| K9 | 64 | PTA12 | CMP2_IN0 | CMP2_IN0 | PTA12 | CAN0_TX | FTM1_CH0 | | I2C2_SCL | I2S0_TXD0 | FTM1_QD_ PHA | |
| J9 | 65 | PTA13/ LLWU_P4 | CMP2_IN1 | CMP2_IN1 | PTA13/ LLWU_P4 | CAN0_RX | FTM1_CH1 | | I2C2_SDA | I2S0_TX_FS | FTM1_QD_ PHB | |
| L10 | 66 | PTA14 | DISABLED | | PTA14 | SPI0_PCS0 | UART0_TX | | I2C2_SCL | I2S0_RX_ BCLK | I2S0_TXD1 | |
| L11 | 67 | PTA15 | DISABLED | | PTA15 | SPI0_SCK | UART0_RX | | | I2S0_RXD0 | | |
| K10 | 68 | PTA16 | DISABLED | | PTA16 | SPI0_SOUT | UART0_ CTS_b | | | I2S0_RX_FS | I2S0_RXD1 | |
| K11 | 69 | PTA17 | ADC1_SE17 | ADC1_SE17 | PTA17 | SPI0_SIN | UART0_ RTS_b | | | I2S0_MCLK | | |
| E8 | 70 | VDD | VDD | VDD | | | | | | | | |
| G8 | 71 | VSS | VSS | VSS | | | | | | | | |
| M12 | 72 | PTA18 | EXTAL0 | EXTAL0 | PTA18 | | FTM0_FLT2 | FTM_CLKIN0 | | | | |
| M11 | 73 | PTA19 | XTAL0 | XTAL0 | PTA19 | | FTM1_FLT0 | FTM_CLKIN1 | | LPTMRO_ ALT1 | | |
| L12 | 74 | RESET_b | RESET_b | RESET_b | | | | | | | | |

Pinout

| 144 MAP BGA | 144 LQFP | Pin Name | Default | ALT0 | ALT1 | ALT2 | ALT3 | ALT4 | ALT5 | ALT6 | ALT7 | EzPort |
|-------------|----------|------------------|-----------------------|-----------------------|------------------|-----------|-----------------|------------------|---------|-----------------|------|--------|
| K12 | 75 | PTA24 | DISABLED | | PTA24 | | | | | FB_A29 | | |
| J12 | 76 | PTA25 | DISABLED | | PTA25 | | | | | FB_A28 | | |
| J11 | 77 | PTA26 | DISABLED | | PTA26 | | | | | FB_A27 | | |
| J10 | 78 | PTA27 | DISABLED | | PTA27 | | | | | FB_A26 | | |
| H12 | 79 | PTA28 | DISABLED | | PTA28 | | | | | FB_A25 | | |
| H11 | 80 | PTA29 | DISABLED | | PTA29 | | | | | FB_A24 | | |
| H10 | 81 | PTB0/ LLWU_P5 | ADC0_SE8/ ADC1_SE8 | ADC0_SE8/ ADC1_SE8 | PTB0/ LLWU_P5 | I2C0_SCL | FTM1_CH0 | | | FTM1_QD_ PHA | | |
| H9 | 82 | PTB1 | ADC0_SE9/ ADC1_SE9 | ADC0_SE9/ ADC1_SE9 | PTB1 | I2C0_SDA | FTM1_CH1 | | | FTM1_QD_ PHB | | |
| G12 | 83 | PTB2 | ADC0_SE12 | ADC0_SE12 | PTB2 | I2C0_SCL | UART0_ RTS_b | | | FTM0_FLT3 | | |
| G11 | 84 | PTB3 | ADC0_SE13 | ADC0_SE13 | PTB3 | I2C0_SDA | UART0_ CTS_b | | | FTM0_FLT0 | | |
| G10 | 85 | PTB4 | ADC1_SE10 | ADC1_SE10 | PTB4 | | | | | FTM1_FLT0 | | |
| G9 | 86 | PTB5 | ADC1_SE11 | ADC1_SE11 | PTB5 | | | | | FTM2_FLT0 | | |
| F12 | 87 | PTB6 | ADC1_SE12 | ADC1_SE12 | PTB6 | | | | FB_AD23 | | | |
| F11 | 88 | PTB7 | ADC1_SE13 | ADC1_SE13 | PTB7 | | | | FB_AD22 | | | |
| F10 | 89 | PTB8 | DISABLED | | PTB8 | | UART3_ RTS_b | | FB_AD21 | | | |
| F9 | 90 | PTB9 | DISABLED | | PTB9 | SPI1_PCS1 | UART3_ CTS_b | | FB_AD20 | | | |
| E12 | 91 | PTB10 | ADC1_SE14 | ADC1_SE14 | PTB10 | SPI1_PCS0 | UART3_RX | | FB_AD19 | FTM0_FLT1 | | |
| E11 | 92 | PTB11 | ADC1_SE15 | ADC1_SE15 | PTB11 | SPI1_SCK | UART3_TX | | FB_AD18 | FTM0_FLT2 | | |
| H7 | 93 | VSS | VSS | VSS | | | | | | | | |
| F5 | 94 | VDD | VDD | VDD | | | | | | | | |
| E10 | 95 | PTB16 | DISABLED | | PTB16 | SPI1_SOUT | UART0_RX | FTM_CLKIN0 | FB_AD17 | EWM_IN | | |
| E9 | 96 | PTB17 | DISABLED | | PTB17 | SPI1_SIN | UART0_TX | FTM_CLKIN1 | FB_AD16 | EWM_OUT_ b | | |
| D12 | 97 | PTB18 | DISABLED | | PTB18 | CAN0_TX | FTM2_CH0 | I2S0_TX_ BCLK | FB_AD15 | FTM2_QD_ PHA | | |
| D11 | 98 | PTB19 | DISABLED | | PTB19 | CAN0_RX | FTM2_CH1 | I2S0_TX_FS | FB_OE_b | FTM2_QD_ PHB | | |
| D10 | 99 | PTB20 | DISABLED | | PTB20 | SPI2_PCS0 | | | FB_AD31 | CMP0_OUT | | |
| D9 | 100 | PTB21 | DISABLED | | PTB21 | SPI2_SCK | | | FB_AD30 | CMP1_OUT | | |
| C12 | 101 | PTB22 | DISABLED | | PTB22 | SPI2_SOUT | | | FB_AD29 | CMP2_OUT | | |
| C11 | 102 | PTB23 | DISABLED | | PTB23 | SPI2_SIN | SPI0_PCS5 | | FB_AD28 | | | |
| B12 | 103 | PTC0 | ADC0_SE14 | ADC0_SE14 | PTC0 | SPI0_PCS4 | PDB0_ EXTRG | | FB_AD14 | I2S0_TXD1 | | |
| B11 | 104 | PTC1/ LLWU_P6 | ADC0_SE15 | ADC0_SE15 | PTC1/ LLWU_P6 | SPI0_PCS3 | UART1_ RTS_b | FTM0_CH0 | FB_AD13 | I2S0_TXD0 | | |

| 144 MAP BGA | 144 LQFP | Pin Name | Default | ALT0 | ALT1 | ALT2 | ALT3 | ALT4 | ALT5 | ALT6 | ALT7 | EzPort |
|-------------------|-------------|--------------------|------------------------|------------------------|--------------------|-----------|-----------------|------------------|--|------------------|----------|--------|
| A12 | 105 | PTC2 | ADC0_SE4b/ CMP1_IN0 | ADC0_SE4b/ CMP1_IN0 | PTC2 | SPI0_PCS2 | UART1_ CTS_b | FTM0_CH1 | FB_AD12 | I2S0_TX_FS | | |
| A11 | 106 | PTC3/ LLWU_P7 | CMP1_IN1 | CMP1_IN1 | PTC3/ LLWU_P7 | SPI0_PCS1 | UART1_RX | FTM0_CH2 | CLKOUT | I2S0_TX_ BCLK | | |
| H8 | 107 | VSS | VSS | VSS | | | | | | | | |
| — | 108 | VDD | VDD | VDD | | | | | | | | |
| A9 | 109 | PTC4/ LLWU_P8 | DISABLED | | PTC4/ LLWU_P8 | SPI0_PCS0 | UART1_TX | FTM0_CH3 | FB_AD11 | CMP1_OUT | | |
| D8 | 110 | PTC5/ LLWU_P9 | DISABLED | | PTC5/ LLWU_P9 | SPI0_SCK | LPTMR0_ ALT2 | I2S0_RXD0 | FB_AD10 | CMP0_OUT | FTM0_CH2 | |
| C8 | 111 | PTC6/ LLWU_P10 | CMP0_IN0 | CMP0_IN0 | PTC6/ LLWU_P10 | SPI0_SOUT | PDB0_ EXTRG | I2S0_RX_ BCLK | FB_AD9 | I2S0_MCLK | | |
| B8 | 112 | PTC7 | CMP0_IN1 | CMP0_IN1 | PTC7 | SPI0_SIN | USB_SOF_ OUT | I2S0_RX_FS | FB_AD8 | | | |
| A8 | 113 | PTC8 | ADC1_SE4b/ CMP0_IN2 | ADC1_SE4b/ CMP0_IN2 | PTC8 | | FTM3_CH4 | I2S0_MCLK | FB_AD7 | | | |
| D7 | 114 | PTC9 | ADC1_SE5b/ CMP0_IN3 | ADC1_SE5b/ CMP0_IN3 | PTC9 | | FTM3_CH5 | I2S0_RX_ BCLK | FB_AD6 | FTM2_FLT0 | | |
| C7 | 115 | PTC10 | ADC1_SE6b | ADC1_SE6b | PTC10 | I2C1_SCL | FTM3_CH6 | I2S0_RX_FS | FB_AD5 | | | |
| B7 | 116 | PTC11/ LLWU_P11 | ADC1_SE7b | ADC1_SE7b | PTC11/ LLWU_P11 | I2C1_SDA | FTM3_CH7 | I2S0_RXD1 | FB_RW_b | | | |
| A7 | 117 | PTC12 | DISABLED | | PTC12 | | UART4_ RTS_b | | FB_AD27 | FTM3_FLT0 | | |
| D6 | 118 | PTC13 | DISABLED | | PTC13 | | UART4_ CTS_b | | FB_AD26 | | | |
| C6 | 119 | PTC14 | DISABLED | | PTC14 | | UART4_RX | | FB_AD25 | | | |
| B6 | 120 | PTC15 | DISABLED | | PTC15 | | UART4_TX | | FB_AD24 | | | |
| — | 121 | VSS | VSS | VSS | | | | | | | | |
| — | 122 | VDD | VDD | VDD | | | | | | | | |
| A6 | 123 | PTC16 | DISABLED | | PTC16 | | UART3_RX | | FB_CS5_b/ FB_TSIZ1/ FB_BE23_ 16_BLS15_ 8_b | | | |
| D5 | 124 | PTC17 | DISABLED | | PTC17 | | UART3_TX | | FB_CS4_b/ FB_TSIZ0/ FB_BE31_ 24_BLS7_0_ b | | | |
| C5 | 125 | PTC18 | DISABLED | | PTC18 | | UART3_ RTS_b | | FB_TBST_b/ FB_CS2_b/ FB_BE15_8_ BLS23_16_b | | | |
| B5 | 126 | PTC19 | DISABLED | | PTC19 | | UART3_ CTS_b | | FB_CS3_b/ FB_BE7_0_ BLS31_24_b | FB_TA_b | | |

| 144 MAP BGA | 144 LQFP | Pin Name | Default | ALT0 | ALT1 | ALT2 | ALT3 | ALT4 | ALT5 | ALT6 | ALT7 | EzPort |
|-------------|----------|---------------|-----------|-----------|---------------|-----------|-------------|-------------|---------------------------------|-----------|----------|--------|
| A5 | 127 | PTD0/LLWU_P12 | DISABLED | | PTD0/LLWU_P12 | SPI0_PCS0 | UART2_RTS_b | FTM3_CH0 | FB_ALE/ FB_CS1_b/ FB_TS_b | | | |
| D4 | 128 | PTD1 | ADC0_SE5b | ADC0_SE5b | PTD1 | SPI0_SCK | UART2_CTS_b | FTM3_CH1 | FB_CS0_b | | | |
| C4 | 129 | PTD2/LLWU_P13 | DISABLED | | PTD2/LLWU_P13 | SPI0_SOUT | UART2_RX | FTM3_CH2 | FB_AD4 | | I2C0_SCL | |
| B4 | 130 | PTD3 | DISABLED | | PTD3 | SPI0_SIN | UART2_TX | FTM3_CH3 | FB_AD3 | | I2C0_SDA | |
| A4 | 131 | PTD4/LLWU_P14 | DISABLED | | PTD4/LLWU_P14 | SPI0_PCS1 | UART0_RTS_b | FTM0_CH4 | FB_AD2 | EWM_IN | | |
| A3 | 132 | PTD5 | ADC0_SE6b | ADC0_SE6b | PTD5 | SPI0_PCS2 | UART0_CTS_b | FTM0_CH5 | FB_AD1 | EWM_OUT_b | | |
| A2 | 133 | PTD6/LLWU_P15 | ADC0_SE7b | ADC0_SE7b | PTD6/LLWU_P15 | SPI0_PCS3 | UART0_RX | FTM0_CH6 | FB_AD0 | FTM0_FLT0 | | |
| M10 | 134 | VSS | VSS | VSS | | | | | | | | |
| F8 | 135 | VDD | VDD | VDD | | | | | | | | |
| A1 | 136 | PTD7 | DISABLED | | PTD7 | CMT_IRO | UART0_TX | FTM0_CH7 | | FTM0_FLT1 | | |
| C9 | 137 | PTD8 | DISABLED | | PTD8 | I2C0_SCL | UART5_RX | | | FB_A16 | | |
| B9 | 138 | PTD9 | DISABLED | | PTD9 | I2C0_SDA | UART5_TX | | | FB_A17 | | |
| B3 | 139 | PTD10 | DISABLED | | PTD10 | | UART5_RTS_b | | | FB_A18 | | |
| B2 | 140 | PTD11 | DISABLED | | PTD11 | SPI2_PCS0 | UART5_CTS_b | SDHC0_CLKIN | | FB_A19 | | |
| B1 | 141 | PTD12 | DISABLED | | PTD12 | SPI2_SCK | FTM3_FLT0 | SDHC0_D4 | | FB_A20 | | |
| C3 | 142 | PTD13 | DISABLED | | PTD13 | SPI2_SOUT | | SDHC0_D5 | | FB_A21 | | |
| C2 | 143 | PTD14 | DISABLED | | PTD14 | SPI2_SIN | | SDHC0_D6 | | FB_A22 | | |
| C1 | 144 | PTD15 | DISABLED | | PTD15 | SPI2_PCS1 | | SDHC0_D7 | | FB_A23 | | |
| M5 | — | NC | NC | NC | | | | | | | | |
| A10 | — | NC | NC | NC | | | | | | | | |
| B10 | — | NC | NC | NC | | | | | | | | |
| C10 | — | NC | NC | NC | | | | | | | | |

5.2 K21 Pinouts

The below figure shows the pinout diagram for the devices supported by this document. Many signals may be multiplexed onto a single pin. To determine what signals can be used on which pin, see the previous section.

| | 1 | 2 | 3 | 4 | 5 | 6 | 7 | 8 | 9 | 10 | 11 | 12 | |
|---|-----------------------|-----------------------|--|--|------------------------------|---------|--------------------|-------------------|-------------------|------------------|------------------|---------|---|
| A | PTD7 | PTD6/ LLWU_P15 | PTD5 | PTD4/ LLWU_P14 | PTD0/ LLWU_P12 | PTC16 | PTC12 | PTC8 | PTC4/ LLWU_P8 | NC | PTC3/ LLWU_P7 | PTC2 | A |
| B | PTD12 | PTD11 | PTD10 | PTD3 | PTC19 | PTC15 | PTC11/ LLWU_P11 | PTC7 | PTD9 | NC | PTC1/ LLWU_P6 | PTC0 | B |
| C | PTD15 | PTD14 | PTD13 | PTD2/ LLWU_P13 | PTC18 | PTC14 | PTC10 | PTC6/ LLWU_P10 | PTD8 | NC | PTB23 | PTB22 | C |
| D | PTE2/ LLWU_P1 | PTE1/ LLWU_P0 | PTE0 | PTD1 | PTC17 | PTC13 | PTC9 | PTC5/ LLWU_P9 | PTB21 | PTB20 | PTB19 | PTB18 | D |
| E | PTE6 | PTE5 | PTE4/ LLWU_P2 | PTE3 | VDD | VDD | VDD | VDD | PTB17 | PTB16 | PTB11 | PTB10 | E |
| F | PTE10 | PTE9 | PTE8 | PTE7 | VDD | VSS | VSS | VDD | PTB9 | PTB8 | PTB7 | PTB6 | F |
| G | VOUT33 | VREGIN | PTE12 | PTE11 | VREFH | VREFL | VSS | VSS | PTB5 | PTB4 | PTB3 | PTB2 | G |
| H | USB0_DP | USB0_DM | VSS | TAMPER4 | VDDA | VSSA | VSS | VSS | PTB1 | PTB0/ LLWU_P5 | PTA29 | PTA28 | H |
| J | ADC0_DP1 | ADC0_DM1 | ADC0_SE16/ CMP1_IN2/ ADC0_SE21 | TAMPER3 | PTA0 | PTA1 | PTA6 | PTA7 | PTA13/ LLWU_P4 | PTA27 | PTA26 | PTA25 | J |
| K | ADC1_DP1 | ADC1_DM1 | ADC1_SE16/ CMP2_IN2/ ADC0_SE22 | TAMPER2 | TAMPER1 | PTA2 | PTA3 | PTA8 | PTA12 | PTA16 | PTA17 | PTA24 | K |
| L | ADC0_DP0/ ADC1_DP3 | ADC0_DM0/ ADC1_DM3 | DAC0_OUT/ CMP1_IN3/ ADC0_SE23 | DAC1_OUT/ CMP0_IN4/ CMP2_IN3/ ADC1_SE23 | TAMPER0/ RTC_ WAKEUP_B | VBAT | PTA4/ LLWU_P3 | PTA9 | PTA11 | PTA14 | PTA15 | RESET_b | L |
| M | ADC1_DP0/ ADC0_DP3 | ADC1_DM0/ ADC0_DM3 | VREF_OUT/ CMP1_IN5/ CMP0_IN5/ ADC1_SE18 | TAMPER5 | NC | EXTAL32 | XTAL32 | PTA5 | PTA10 | VSS | PTA19 | PTA18 | M |
| | 1 | 2 | 3 | 4 | 5 | 6 | 7 | 8 | 9 | 10 | 11 | 12 | |

Figure 33. K21 144 MAPBGA Pinout Diagram

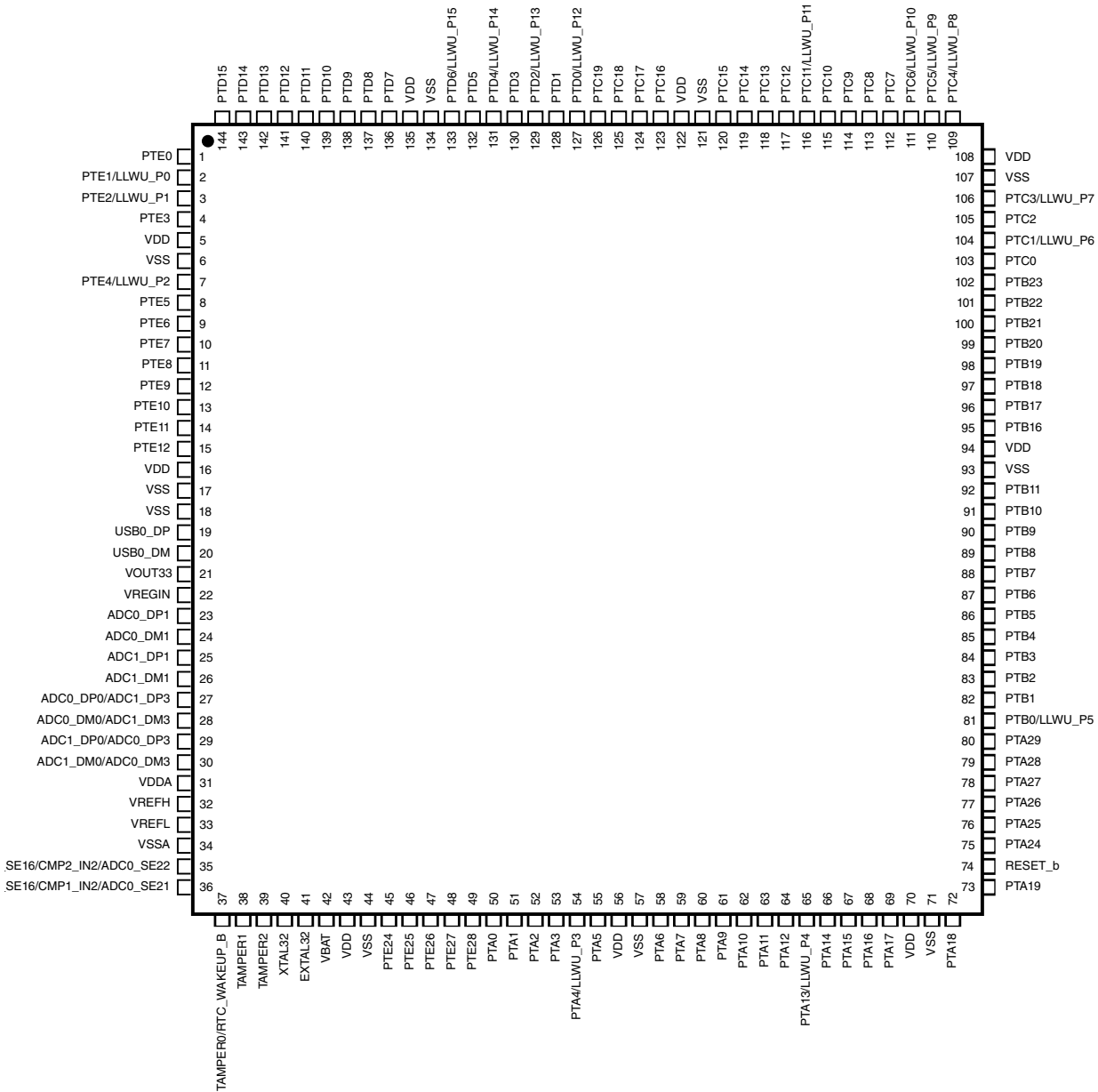

Figure 34. K21 144 LQFP Pinout Diagram

6 Revision History

The following table provides a revision history for this document.

Table 49. Revision History

| Rev. No. | Date | Substantial Changes |
|----------|---------|--|
| 1 | 11/2012 | Alpha customer release |
| 2 | 5/2013 | <ul style="list-style-type: none"> • Updated supported part numbers and document number • Updated section "Voltage and current operating behaviors" • Added Drylce Tamper Electrical Specifications • Added the following figures: <ul style="list-style-type: none"> • Run mode supply current vs. core frequency • VLPR mode supply current vs. core frequency • Updated section "Device clock specifications" • Updated section "Power consumption operating behaviors" • Updated section "Power mode transition operating behaviors" • Updated section "JTAG limited voltage range electricals" • Updated section "MCG specifications" • Updated section "Oscillator DC electrical specifications" • Updated section "16-bit ADC operating conditions" • Updated the pinouts • Added section "Alternate part numbers for small packages" |
| 3 | 08/2013 | <ul style="list-style-type: none"> • Updated section "Power consumption operating behaviors" • Updated the "Run mode supply current vs. core frequency" figure in section "Diagram: Typical IDD_RUN operating behavior" |
| 4 | 11/2014 | <ul style="list-style-type: none"> • Updated the table "Voltage and current operating behavior" • Format changes |

How to Reach Us:

Home Page:

freescale.com

Web Support:

freescale.com/support

Information in this document is provided solely to enable system and software implementers to use Freescale products. There are no express or implied copyright licenses granted hereunder to design or fabricate any integrated circuits based on the information in this document.

Freescale reserves the right to make changes without further notice to any products herein.

Freescale makes no warranty, representation, or guarantee regarding the suitability of its products for any particular purpose, nor does Freescale assume any liability arising out of the application or use of any product or circuit, and specifically disclaims any and all liability, including without limitation consequential or incidental damages.

“Typical” parameters that may be provided in Freescale data sheets and/or specifications can and do vary in different applications, and actual performance may vary over time. All operating parameters, including “typicals,” must be validated for each customer application by customer’s technical experts. Freescale does not convey any license under its patent rights nor the rights of others. Freescale sells products pursuant to standard terms and conditions of sale, which can be found at the following address: freescale.com/SalesTermsandConditions.

Freescale, the Freescale logo, Energy Efficient Solutions logo, and Kinetis are trademarks of Freescale Semiconductor, Inc., Reg. U.S. Pat. & Tm. Off. All other product or service names are the property of their respective owners. ARM and Cortex are registered trademarks of ARM Limited (or its subsidiaries) in the EU and/or elsewhere. All rights reserved.

©2013-2014 Freescale Semiconductor, Inc.



Компания «ЭлектроПласт» предлагает заключение долгосрочных отношений при поставках импортных электронных компонентов на взаимовыгодных условиях!

Наши преимущества:

- Оперативные поставки широкого спектра электронных компонентов отечественного и импортного производства напрямую от производителей и с крупнейших мировых складов;
- Поставка более 17-ти миллионов наименований электронных компонентов;
- Поставка сложных, дефицитных, либо снятых с производства позиций;
- Оперативные сроки поставки под заказ (от 5 рабочих дней);
- Экспресс доставка в любую точку России;
- Техническая поддержка проекта, помощь в подборе аналогов, поставка прототипов;
- Система менеджмента качества сертифицирована по Международному стандарту ISO 9001;
- Лицензия ФСБ на осуществление работ с использованием сведений, составляющих государственную тайну;
- Поставка специализированных компонентов (Xilinx, Altera, Analog Devices, Intersil, Interpoint, Microsemi, Aeroflex, Peregrine, Syfer, Eurofarad, Texas Instrument, Miteq, Cobham, E2V, MA-COM, Hittite, Mini-Circuits, General Dynamics и др.);

Помимо этого, одним из направлений компании «ЭлектроПласт» является направление «Источники питания». Мы предлагаем Вам помощь Конструкторского отдела:

- Подбор оптимального решения, техническое обоснование при выборе компонента;
- Подбор аналогов;
- Консультации по применению компонента;
- Поставка образцов и прототипов;
- Техническая поддержка проекта;
- Защита от снятия компонента с производства.



Как с нами связаться

Телефон: 8 (812) 309 58 32 (многоканальный)

Факс: 8 (812) 320-02-42

Электронная почта: org@eplast1.ru

Адрес: 198099, г. Санкт-Петербург, ул. Калинина, дом 2, корпус 4, литера А.