

DESCRIPTION

Demonstration circuit 1339 features the LTC2302 low noise, 500ksps, 12-Bit, ADC. The LTC2302 has an SPI compatible serial interface that can be used to select channel polarity and unipolar or bipolar settings. DC1339A demonstrates the DC and AC performance of the LTC2302 in conjunction with the DC590B QuikEval and DC890B Fast DAACS data collection boards. Use DC590B to demonstrate DC performance such as peak-to-peak noise and DC linearity. Use

DC890B if precise sampling rates are required or to demonstrate AC performance such as SNR, THD, SINAD and SFDR. Alternatively, by connecting the DC1339A into a customer application, the performance of the LTC2302 can be evaluated directly in that circuit.

Design files for this circuit board are available. Call the LTC factory.

LTC is a trademark of Linear Technology Corporation

Figure 1. DC1339A Connection Diagram

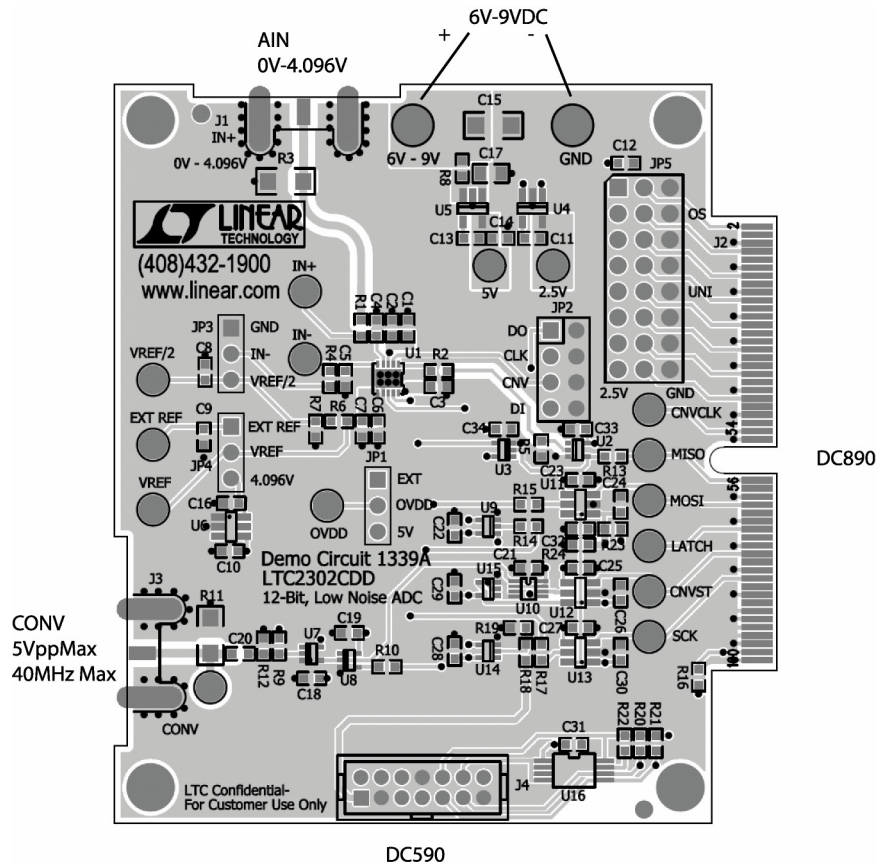

DC890B QUICK START PROCEDURE

Connect DC1339A to a DC890B USB High Speed Data Collection Board using connector J2. Connect DC890B to a host PC with a standard USB A/B cable. Apply 6V-9V DC to the 6V-9V and GND terminals. Apply a low jitter signal source to IN+ on connector J1. Apply a low jitter clock with a maximum frequency of 40MHz to connector J3. The clock can be a sine wave or square wave with maximum amplitude of 14dBm. Note that J3

has a 50Ω termination resistor to ground, which will prevent most logic from driving this pin directly. Run the Fast DAACS software (Pscope.exe version K51 or later) supplied with DC890B or download it from www.linear.com. Complete software documentation is available from the Help menu. Updates can be downloaded from the Tools menu. Check for updates periodically as new features may be added.

PSCOPE SOFTWARE CONFIGURATION

The Pscope software will recognize DC1339A and configure itself automatically. The default configuration is for IN+ with respect to IN- in unipolar mode. Make sure that the jumpers are set as shown in Figure 2. If bipolar mode is desired, it will be necessary to change the Pscope ADC configuration setting as well as jumpers JP3 and JP5. From the front page of the software select ADC Configuration from the Configure menu. Select 12-Bits, Alignment 12, FPGA Ld Serial 2308 Class, 1-Channel. Do not check Positive Edge Clk.

Check Bipolar if the JP5 UNI jumper is set to GND. An example of the ADC configuration menu is shown in Figure 3. JP3 should be changed from GND to VREF/2 in bipolar mode, so that the minus input is biased halfway between ground and Vref.

Click the Collect button (See Figure 4) to begin acquiring data. Depending on which board was previously used by Pscope it may be necessary to press Collect a second time. The Collect button then changes to Pause, which can be used to pause data acquisition.

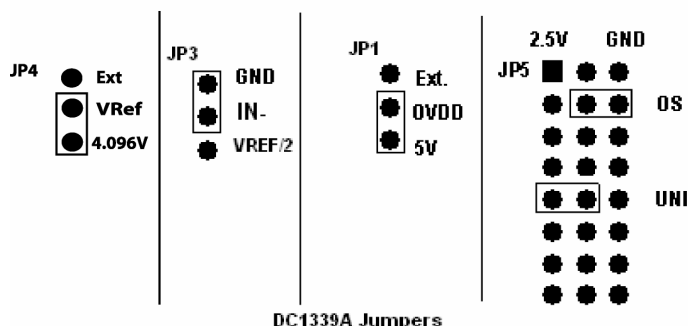

Figure 2. Jumper Settings

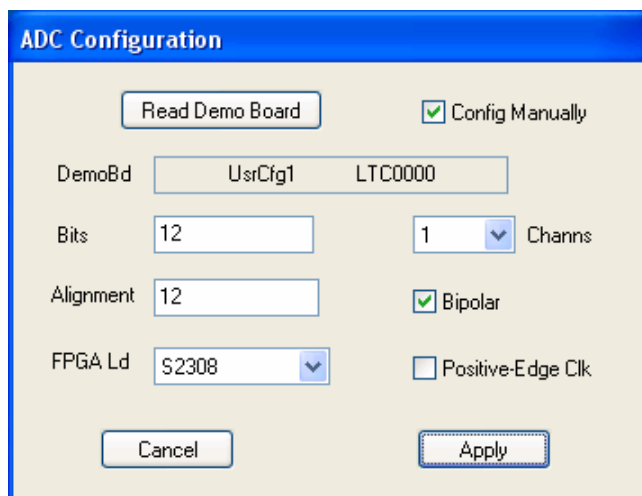

Figure 3. User Configure Menu

DC590B QUICK START PROCEDURE

Connect DC1339A to a DC590 USB serial controller using the supplied 14-conductor ribbon cable. Connect DC590 to a host PC with a standard USB A/B cable. Run the evaluation software supplied with DC590 or download it from www.linear.com. The correct control panel will be loaded automatically.

Version K73 of QuikEval or higher should be used for this board. Click the COLLECT button to begin reading the ADC. Change the range (unipolar or bipolar) by right clicking over the range indicator in the display. See Figure 5.

HARDWARE SET UP

SIGNAL CONNECTIONS

J1 SMA connector for IN+. Limit input swings to 0V-4.096V. For optimum performance, the input should be band limited to the frequencies of interest. See schematic for details.

J2 FastDAACS interface to DC890B. Do not use J4 at the same time.

J3 Conversion Clock Input. This input has a 50Ω termination resistor, and is intended to be driven by a 14dBm sine or square wave. To achieve full AC performance of this part, the clock jitter should be kept under 20ps. This input is capacitively coupled to a clock buffer so that level shifting is not required. To run at maximum conversion rate, apply a 40MHz signal to this connector. J3 is used only for DC890B. DC590B generates its own clock signal.

J4 Quick Eval interface to DC590B. Do not use J2 at the same time. This connector can also be used to drive the ADC directly. See schematic for details.

JUMPERS

JP1 (OVDD) connects the OVDD pin of the ADC to 5V or to an external voltage. The SDO pin swings from ground to OVDD.

JP2 contains CONV, SDI, SCK and a buffered SDO signal. This connector is intended to monitor these signals. For those who want to drive the ADC directly use J4.

JP3 (IN-) selects whether the IN- pin of the ADC is to be cleanly grounded near the ADC or connected to VREF/2.

JP4 (VREF) selects onboard or external reference for the ADC

JP5 (DIN Word) selects the channel configuration and unipolar/bipolar settings of the ADC. (JP5 is used by the DC890B only. It is ignored by the DC590B.)

GROUNDING AND POWER CONNECTION

Connect a 6V to 9V power supply to the 6-9VDC and GND posts when using DC890B. If the DC590B is used it will provide power to the DC1339.

QUICK START GUIDE FOR DEMONSTRATION CIRCUIT 1339

LOW NOISE, 500KSPS, 12-BIT ADC

Figure 4. DC1339A Pscope Screenshot

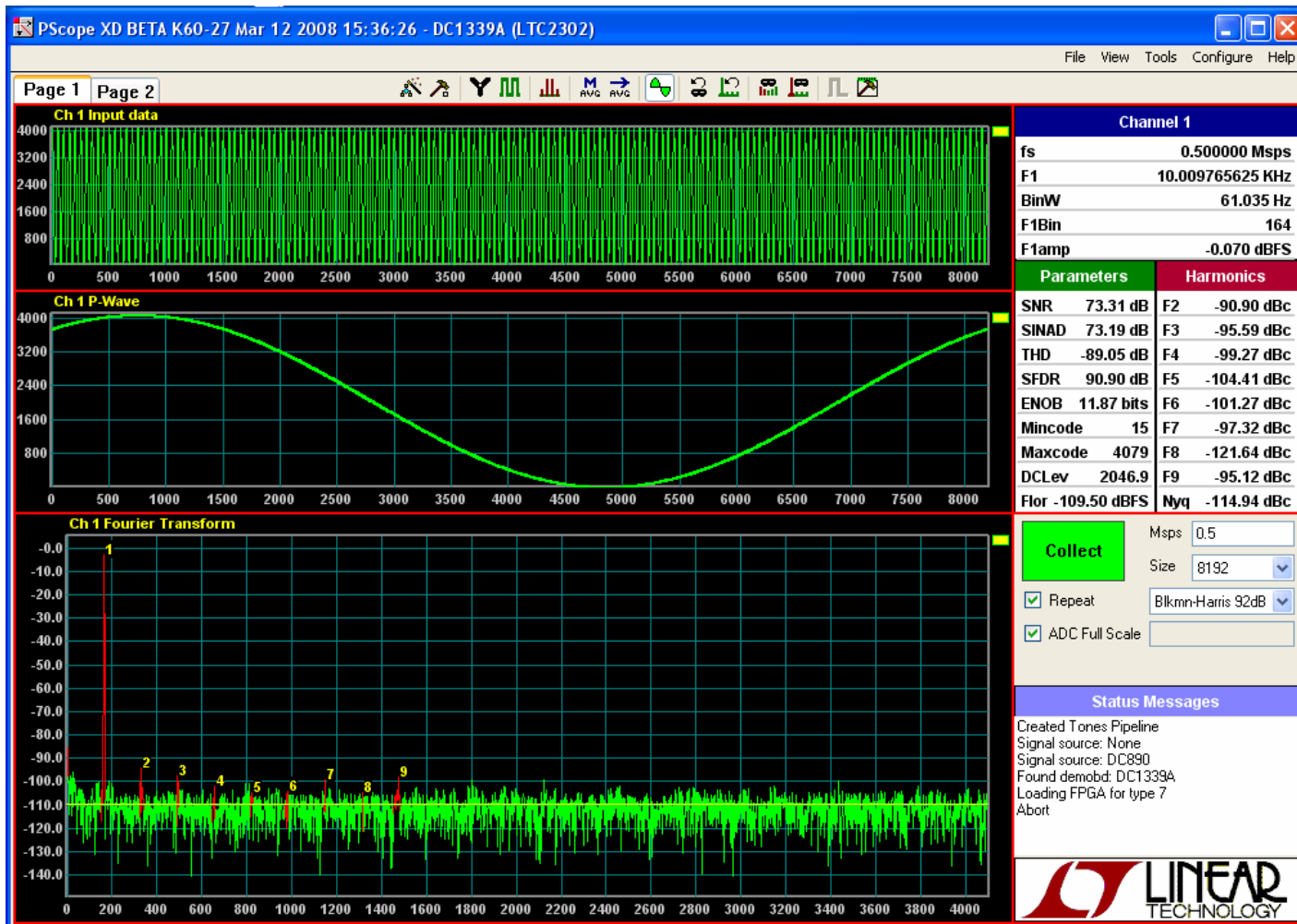
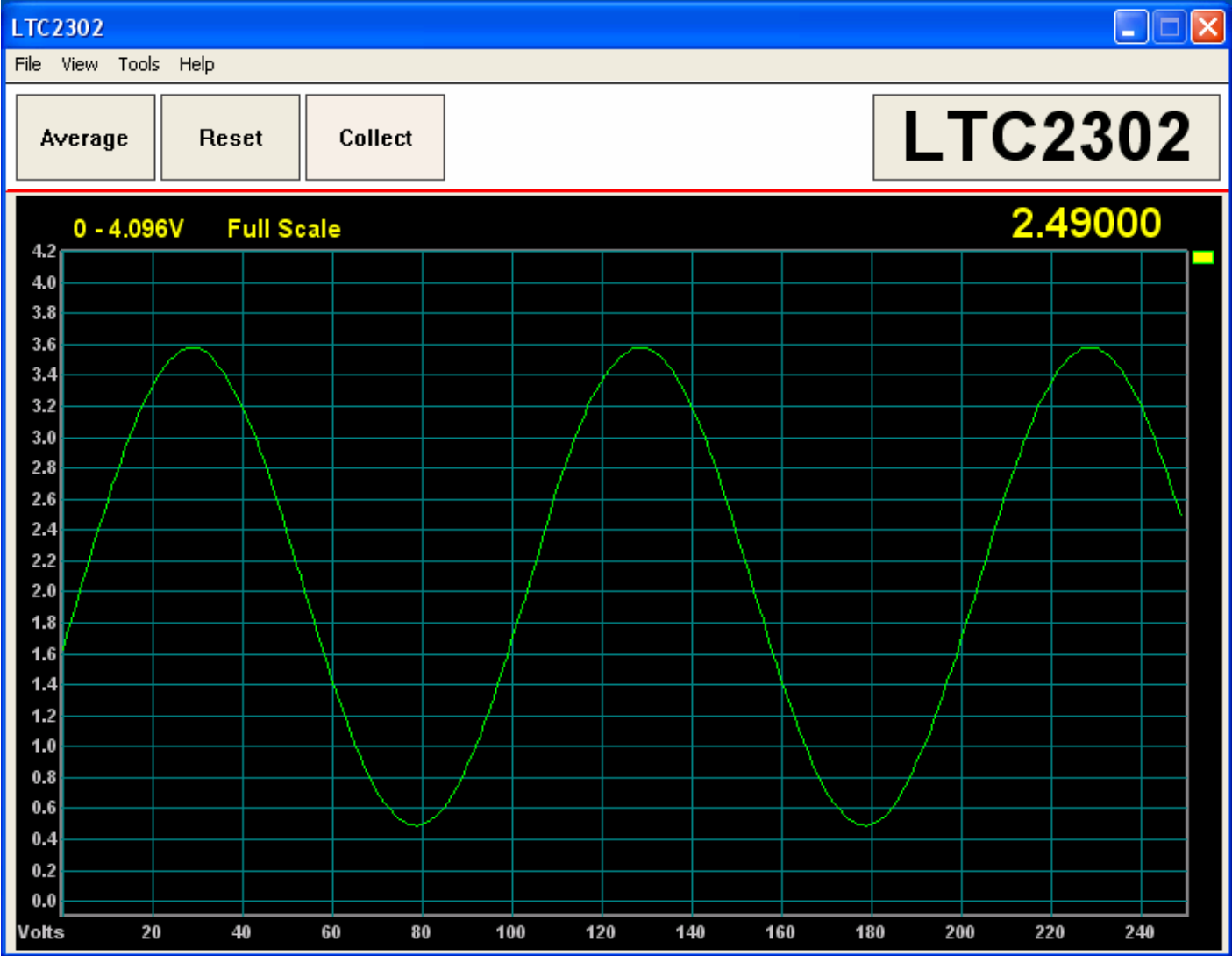
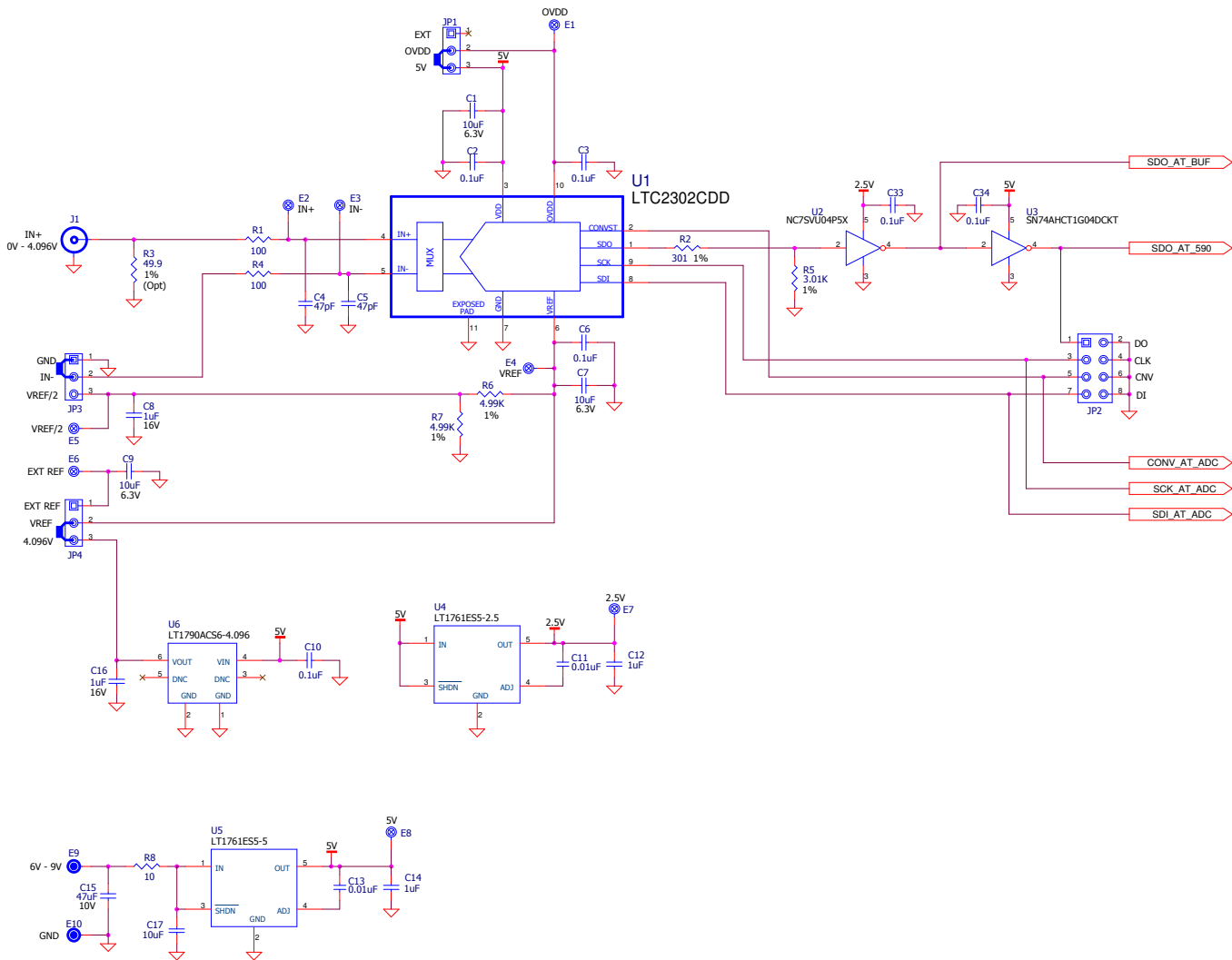

Figure 5. DC1339A QuikEval Screen Shot



QUICK START GUIDE FOR DEMONSTRATION CIRCUIT 1339

LOW NOISE, 500KSPS, 12-BIT ADC



QUICK START GUIDE FOR DEMONSTRATION CIRCUIT 1339

LOW NOISE, 500KSPS, 12-BIT ADC

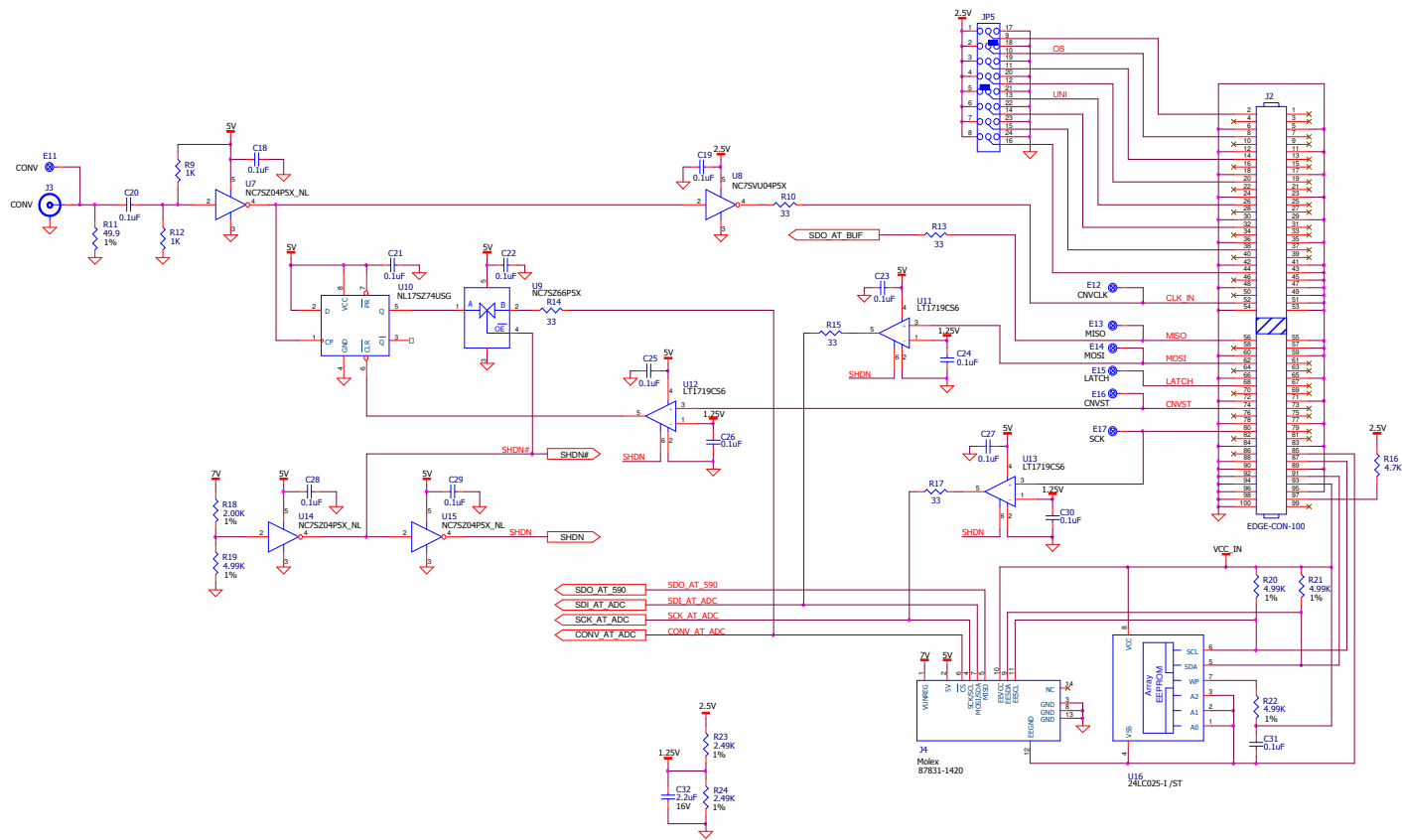



Компания «ЭлектроПласт» предлагает заключение долгосрочных отношений при поставках импортных электронных компонентов на взаимовыгодных условиях!

Наши преимущества:

- Оперативные поставки широкого спектра электронных компонентов отечественного и импортного производства напрямую от производителей и с крупнейших мировых складов;
- Поставка более 17-ти миллионов наименований электронных компонентов;
- Поставка сложных, дефицитных, либо снятых с производства позиций;
- Оперативные сроки поставки под заказ (от 5 рабочих дней);
- Экспресс доставка в любую точку России;
- Техническая поддержка проекта, помощь в подборе аналогов, поставка прототипов;
- Система менеджмента качества сертифицирована по Международному стандарту ISO 9001;
- Лицензия ФСБ на осуществление работ с использованием сведений, составляющих государственную тайну;
- Поставка специализированных компонентов (Xilinx, Altera, Analog Devices, Intersil, Interpoint, Microsemi, Aeroflex, Peregrine, Syfer, Eurofarad, Texas Instrument, Miteq, Cobham, E2V, MA-COM, Hittite, Mini-Circuits, General Dynamics и др.);

Помимо этого, одним из направлений компании «ЭлектроПласт» является направление «Источники питания». Мы предлагаем Вам помощь Конструкторского отдела:

- Подбор оптимального решения, техническое обоснование при выборе компонента;
- Подбор аналогов;
- Консультации по применению компонента;
- Поставка образцов и прототипов;
- Техническая поддержка проекта;
- Защита от снятия компонента с производства.



Как с нами связаться

Телефон: 8 (812) 309 58 32 (многоканальный)

Факс: 8 (812) 320-02-42

Электронная почта: org@eplast1.ru

Адрес: 198099, г. Санкт-Петербург, ул. Калинина, дом 2, корпус 4, литера А.