

PRODUCT NUMBER
SEE TABLE

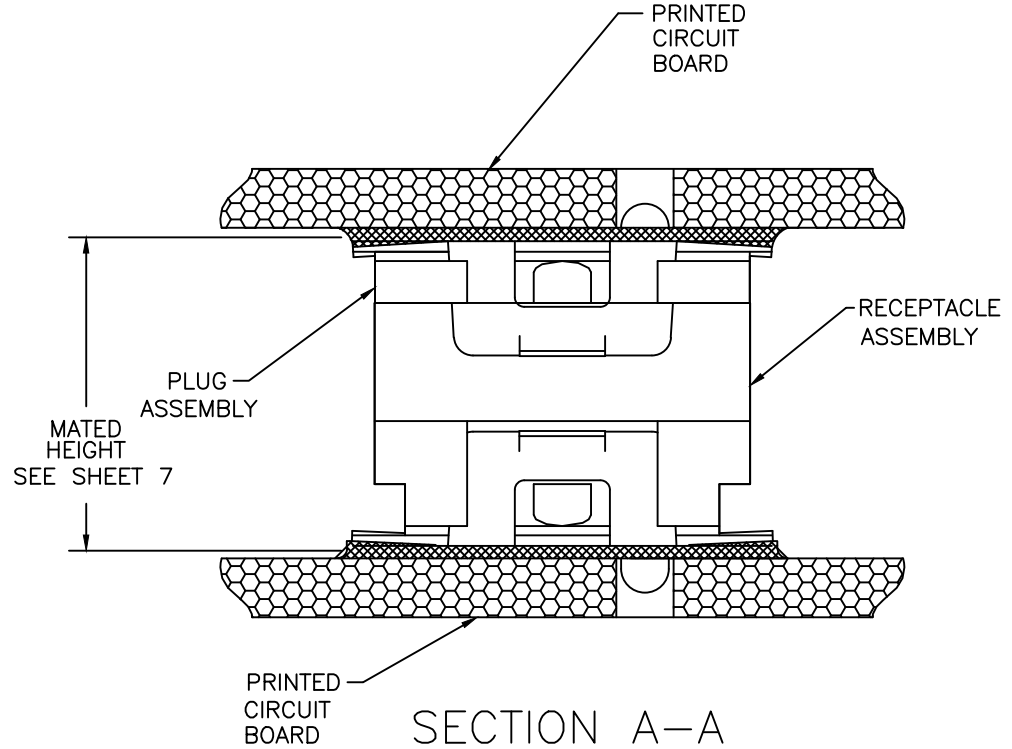

SECTION A-A
ROTATED 90°
N.T.S.

mat'l. code		surface ISO 1302		tolerance ISO 406 ISO 1101		projection 		product family CONAN®	
ltr	ecn no	dr	date	tolerances unless otherwise specified		INCH/MM		title	
A	N11-0214	J.Z	2011-07-20	angles	linear	.XX±.01/XX±.3		CONAN® CONNECTOR ASSEMBLY	
B	ELX-N-05460	J.Z	2011-08-23			.XXX±.005/XXX±.13		dwg no	
C	ELX-N-14210	GM	2013-03-07	0°±2'		.XXXX±.0020/XXXX±.051		sheet 1 of 7 size	
-	-	-	-	dr	J.ZHOU	2011-07-20		10118744	
-	-	-	-	enr	J.ZHOU	2011-07-20		A3	
-	-	-	-	chr	J.ZHOU	2011-07-20		type	
-	-	-	-	appd	R.BIAN	2011-07-20		Product Customer Drawing	
sheet	revision	C	C	C	C	C	C		
index	sheet	1	2	3	4	5	6	7	



Copyright FCI

PRODUCT NUMBER
SEE TABLE

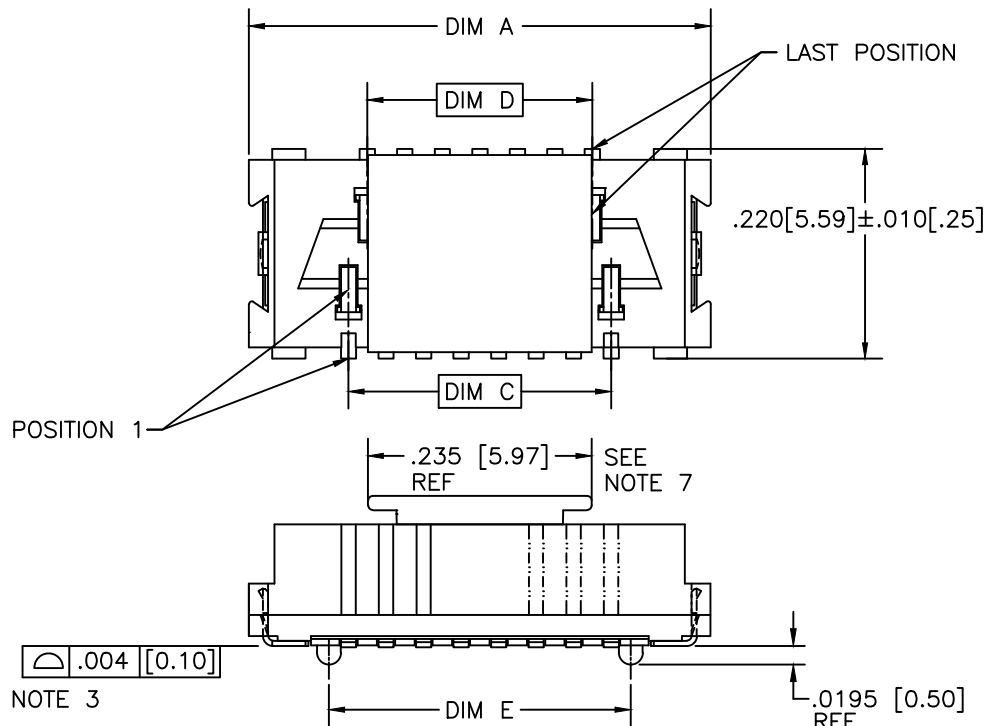

RECEPTACLE

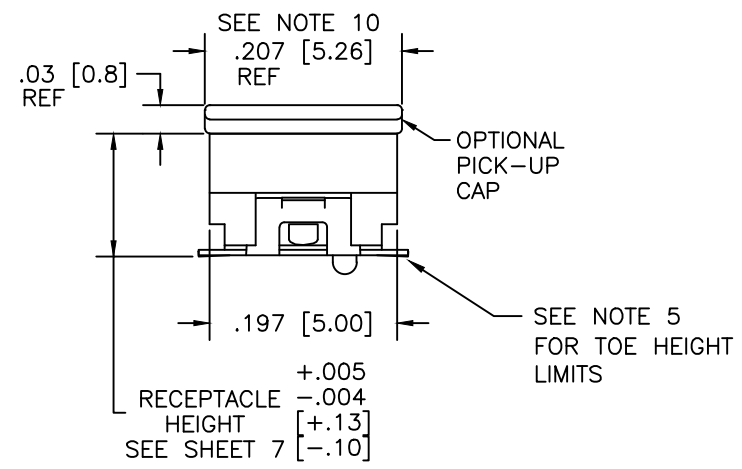

OPEN KNIT LINE PERMISSIBLE IN THIS AREA.

mat'l. code		surface ISO 1302 ✓	tolerance ISO 406 ISO 1101	projection INCH/MM	product family CONAN®
ltr	ecn no	dr	date	title CONAN® CONNECTOR ASSEMBLY	
c				linear	scale 5:1
				angles	
				0°±2'	
		dr	J.ZHOU 2011-07-20		sheet 2 of 7 size
		enr	J.ZHOU 2011-07-20		10118744 A3
		chr	J.ZHOU 2011-07-20		type Product Customer Drawing
		appd	R.BIAN 2011-07-20		
sheet index	revision sheet				

PRODUCT NUMBER
SEE TABLE

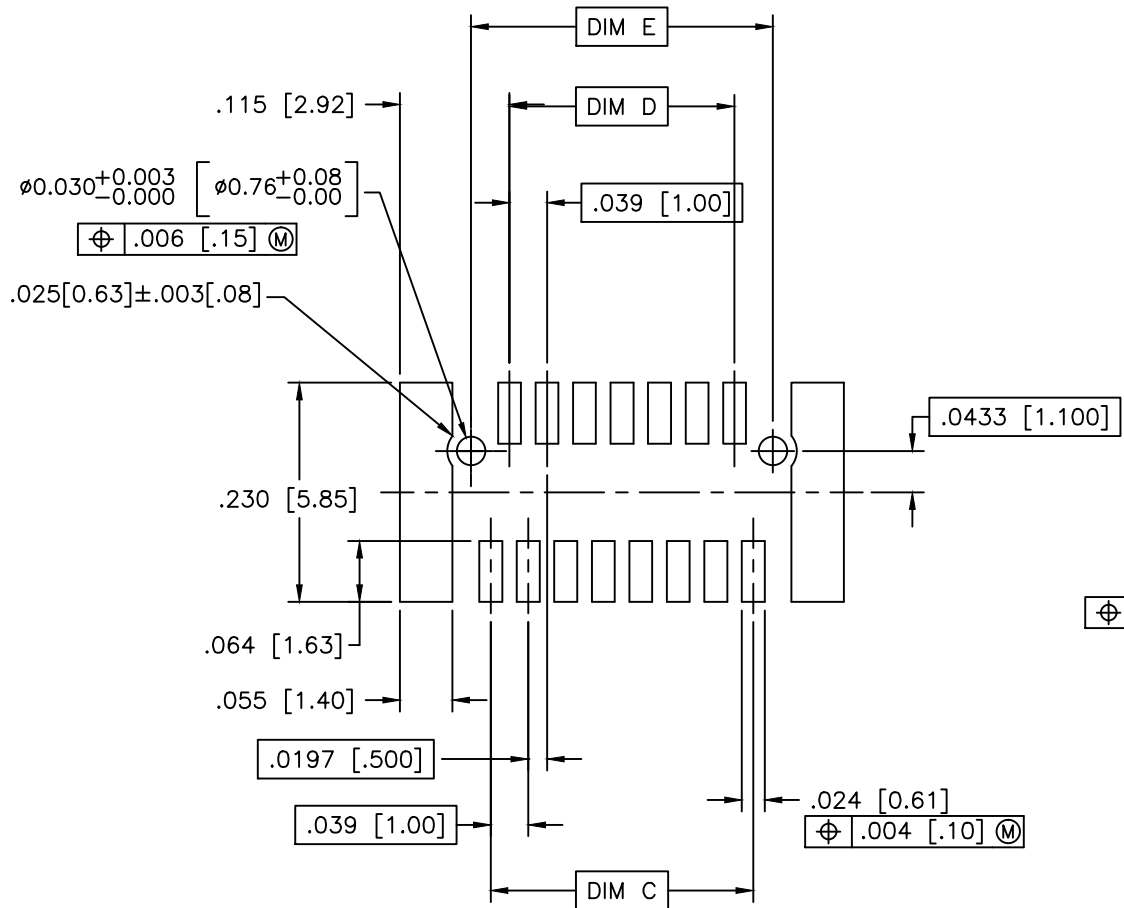

RECOMMENDED
PAD LAYOUT
FOR RECEPTACLE

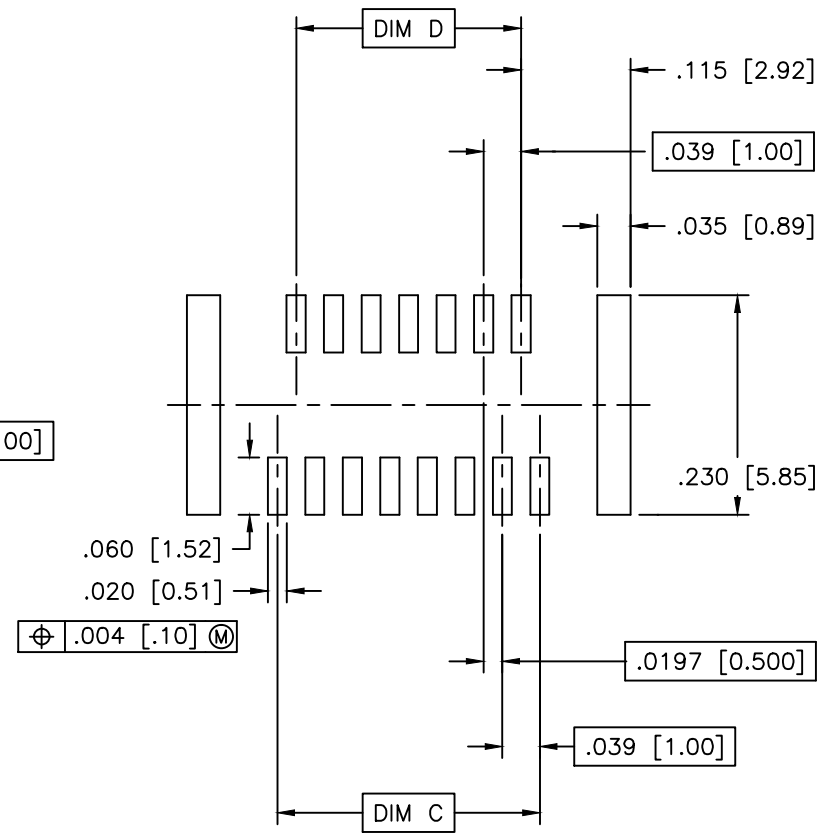

RECOMMENDED
STENCIL LAYOUT
FOR RECEPTACLE

mat'l. code		surface ISO 1302 <input checked="" type="checkbox"/>	tolerance ISO 406 ISO 1101	projection 	product family CONAN [®]
ltr	ecn no	dr	date	tolerances unless otherwise specified	title
c				linear XXX±.01/XX±0.3 XXX±.005/XX±0.13 XXX±.0020/XX±0.051	CONAN [®] CONNECTOR ASSEMBLY
				angles 0°±2'	dwg no 10118744
		dr	J.ZHOU	2011-07-20	sheet 3 of 7 size A3
		enr	J.ZHOU	2011-07-20	type Product Customer Drawing
		chr	J.ZHOU	2011-07-20	
		appd	R.BIAN	2011-07-20	
sheet index	revision sheet				



PRODUCT NUMBER
SEE TABLE

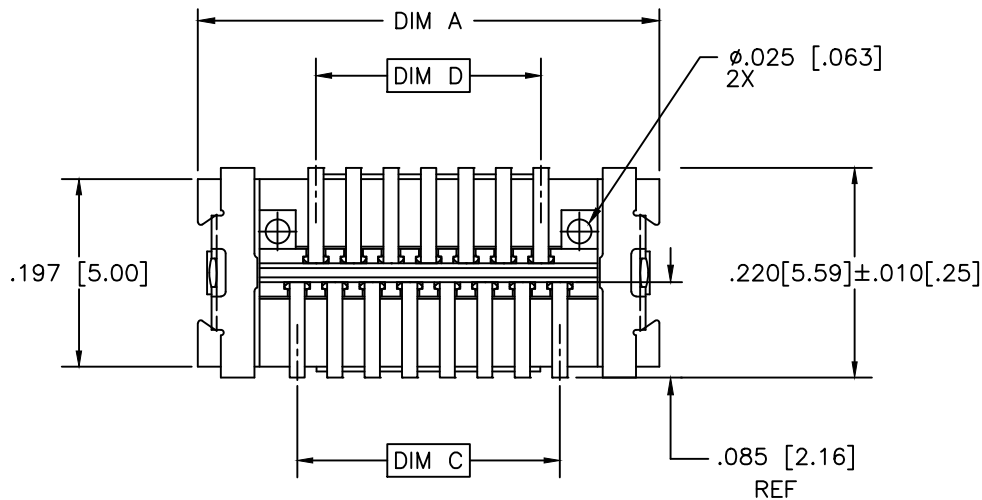

PLUG

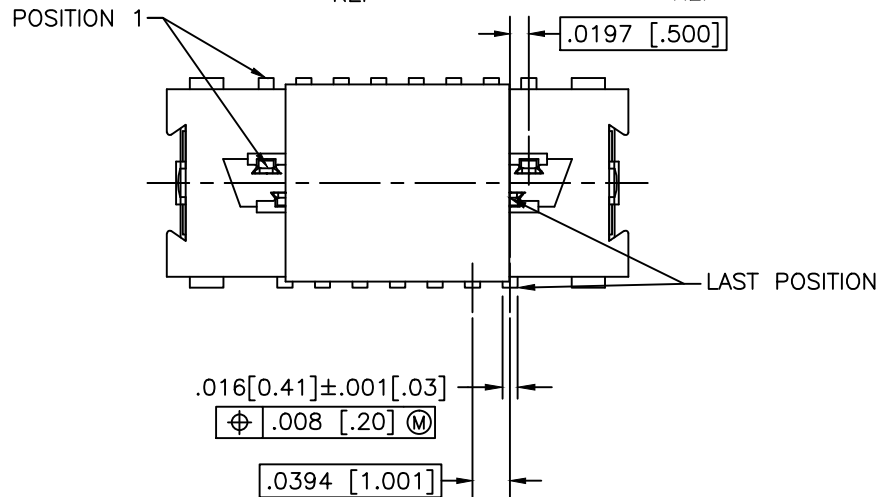
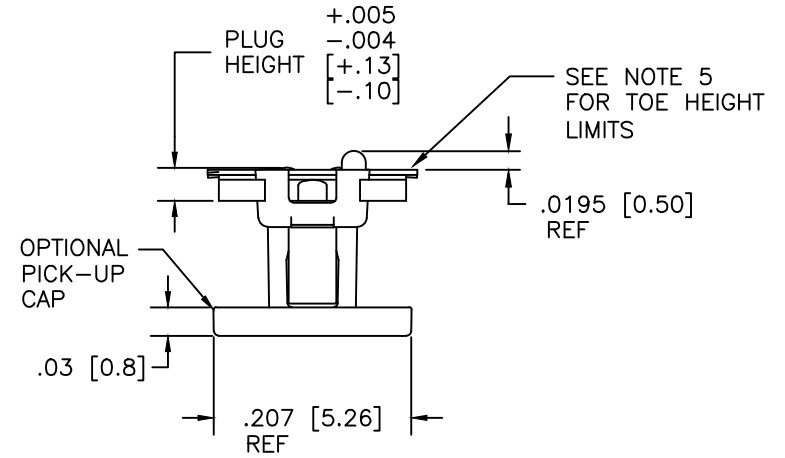
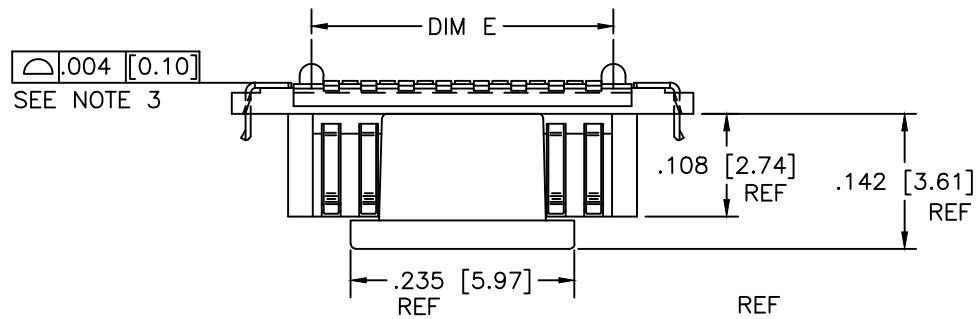

mat'l. code		surface ISO 1302	tolerance ISO 406 ISO 1101	projection 	product family CONAN [®]
ltr	ecn no	dr	date	tolerances unless otherwise specified	title
c				linear XX±.01/XX±0.3 XXX±.005/XXX±0.13 XXXX±.0020/XXXX±0.051	CONAN [®] CONNECTOR ASSEMBLY
				angles 0°±2'	INCH/MM
				dr	scale 5:1
				enr	J.ZHOU 2011-07-20
				chr	J.ZHOU 2011-07-20
				appd	R.BIAN 2011-07-20
sheet index	revision sheet				FCJ
					dwg no 10118744
					sheet 4 of 7 size A3
					type Product Customer Drawing

PRODUCT NUMBER
SEE TABLE



RECOMMENDED
PAD LAYOUT
FOR PLUG

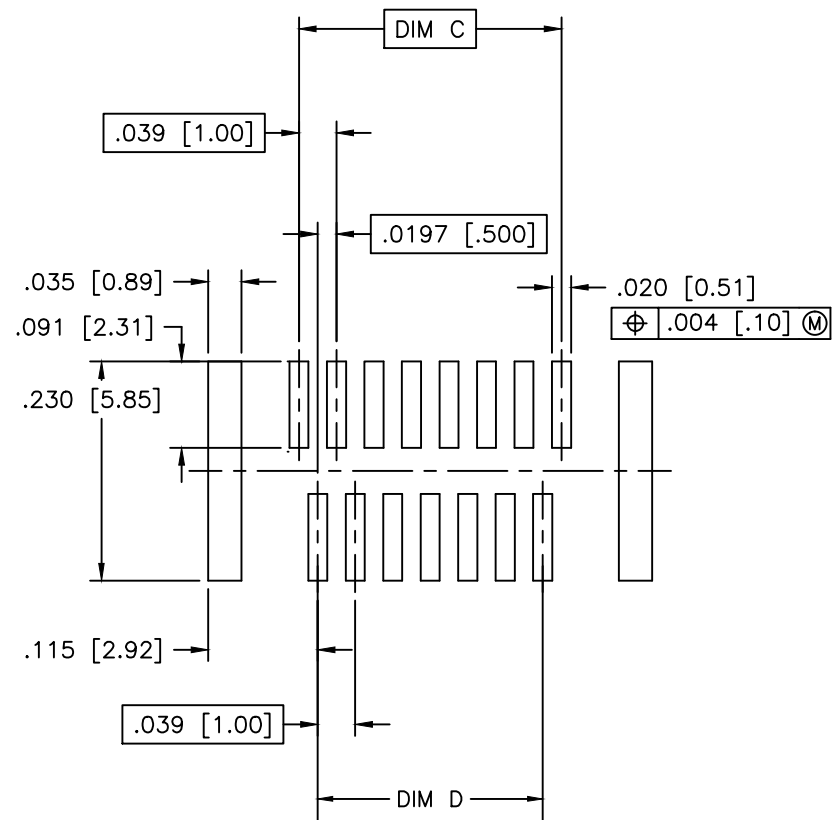

RECOMMENDED
STENCIL LAYOUT
FOR PLUG

mat'l. code		surface ISO 1302	tolerance ISO 406 ISO 1101	projection 	product family CONAN [®]
ltr	ecn no	dr	date	tolerances unless otherwise specified	title
c				linear XX±.01/XX±0.3 XXX±.005/XXX±0.13 XXXX±.0020/XXXX±0.051	CONAN [®] CONNECTOR ASSEMBLY
				angles 0°±2'	INCH/MM
				dr	J.ZHOU 2011-07-20
				enr	J.ZHOU 2011-07-20
				chr	J.ZHOU 2011-07-20
				appd	R.BIAN 2011-07-20
sheet index	revision sheet				dwg no 10118744
					sheet 5 of 7 size A3
					type Product Customer Drawing

PRODUCT NUMBER	POS	DIM "A"	DIM "C"	DIM "D"	DIM "E"
10118744-TCWXY09LF	9	.366 [9.30]	.157 [4.00]	.118 [3.00]	.1990 [5.055]
-TCWXY11LF	11	.406 [10.30]	.197 [5.00]	.157 [4.00]	.2380 [6.045]
-TCWXY15LF	15	.484 [12.30]	.276 [7.00]	.236 [6.00]	.3170 [8.052]
-TCWXY21LF	21	.602 [15.30]	.394 [10.00]	.354 [9.00]	.4350 [11.049]
-TCWXY25LF	25	.681 [17.30]	.472 [12.00]	.433 [11.00]	.5140 [13.056]
-TCWXY31LF	31	.800 [20.30]	.591 [15.00]	.551 [14.00]	.6320 [16.053]
-TCWXY41LF	41	.996 [25.30]	.787 [20.00]	.748 [19.00]	.8290 [21.057]
-TCWXY51LF	51	1.193 [30.30]	.984 [25.00]	.945 [24.00]	1.0260 [26.060]
-TCWXY69LF	69	1.547 [39.30]	1.339 [34.00]	1.299 [33.00]	1.3800 [35.052]

NOTES:

1. MATERIALS:

RECEPTACLE HOUSING - LCP, UL-94V-0. COLOR: NATURAL.

RECEPTACLE TERMINALS - COPPER ALLOY, PLATED WITH GOLD OR GXT IN CONTACT AREA AND 100u"/2.54u Sn ON SOLDER LEGS WITH AN OVERALL 50u"/1.27u Ni UNDERPLATE.

PLUG HOUSING - LCP, UL-94V-0. COLOR: NATURAL.

PLUG TERMINALS - COPPER ALLOY, PLATED WITH GOLD OR GXT IN CONTACT AREA AND 100u"/2.54u Sn ON SOLDER LEGS WITH AN OVERALL 50u"/1.27u Ni UNDERPLATE.

RETENTION DEVICE - BRASS, PLATED WITH 100u"/2.54u Sn OVER NICKEL.

2. REFERENCE GS-12-0977 FOR PRODUCT PERFORMANCE AND ENVIRONMENTAL RESISTANCE DATA.

3. SEE TA-774 FOR FURTHER DESCRIPTION OF HOW THIS DIMENSION IS APPLIED.

4. RECOMMENDED SOLDER PASTE THICKNESS IS .006 TO .008 INCHES THICK.

5. THE TOE HEIGHT OF THE SOLDER TAIL SHALL BE MEASURED FROM THE LOWEST POINT OF THE .004 CO-PLANARITY GRAVITY PLANE. THIS MEASUREMENT IS NOT TO EXCEED A WINDOW OF .000 TO .007 INCHES.

6. THREE SLOTS MAY BE LOCATED AT EITHER END OF HOUSING.

7. THE HOUSING WILL WITHSTAND EXPOSURE TO 260°C PEAK TEMPERATURE FOR 30 SECONDS IN A CONVECTION INFRA RED OR VAPOR PHASE REFLOW OVEN. SEE APPLICATION/PROCEDURES IF THEY ARE AVAILABLE

8. PRODUCT WITH "LF" AT THE END MEETS EUROPEAN UNION DIRECTIVES AND OTHER COUNTRY REGULATION AS DESCRIBED IN GS-22-008.



Copyright FCI

mat'l. code		surface ISO 1302	tolerance ISO 406 ISO 1101	projection 	product family CONAN®
ltr	ecn no	dr	date	tolerances unless otherwise specified	title
c				linear X.X±.01/X±0.3 XXX±.005/XXX±0.13 XXXX±.0020/XXX±0.051	CONAN® CONNECTOR ASSEMBLY
				angles 0°±2'	INCH/MM
				dr	scale 5:1
				enr	J.ZHOU 2011-07-20
				chr	J.ZHOU 2011-07-20
				appd	R.BIAN 2011-07-20
sheet index	revision sheet				FCI
					dwg no 10118744 sheet 6 of 7 size A3
					type Product Customer Drawing

PRODUCT NUMBER
SEE TABLE

CONAN® ASSEMBLY PART NUMBER

10118744 - T C W 3 Y ZZ LF

LEAD FREE
SEE NOTE 8

TYPE	T
PLUG WITH PEGS	1
RECEPTACLE WITH PEGS	3

Y	PLUG HEIGHT	RECEPTACLE HEIGHT	MATED HEIGHT +.010 -.008 [+.25] [-.20]
1	.034 [.86]	.129 [3.28]	.163 [4.15]
2	.048 [1.23]	SEE Y=1 FOR ALL RECEPTACLES	.177 [4.50]
3	.068 [1.73]		.197 [5.00]
4	.107 [2.72]		.236 [6.00]
5	.1465 [3.721]		.276 [7.00]

ZZ	NUMBER OF POSITIONS
09	9
11	11
15	15
21	21
25	25
31	31
41	41
51	51
69	69

PICK AND PLACE CAP OR TAPE	C
WITH CAP	1

PACKAGING	W
PRESSURE SEALED TAPE & REEL	3

EXAMPLE: 10118744-3131125LF
IS A CONAN® RECEPTACLE ASSEMBLY,
HAVING PEGS AND WITH A PICK AND PLACE CAP.
IT IS .13 [3.2] HIGH AND 25 POSITIONS AND IS
PACKAGED IN PRESSURE SEALED TAPE, REEL AND LEAD FREE.

mat'l. code		surface ISO 1302 ✓	tolerance ISO 406 ISO 1101	projection 	product family CONAN®
ltr	ecn no	dr	date	tolerances unless otherwise specified	title
C				linear XXX±.01/XXX0.3 XXX±.005/XXX0.13 XXX±.0020/XXX±0.051	CONAN® CONNECTOR ASSEMBLY
				angles 0°±2'	INCH/MM scale 5:1
		dr	J.ZHOU 2011-07-20		dwg no
		enr	J.ZHOU 2011-07-20		sheet 7 of 7 size
		chr	J.ZHOU 2011-07-20		10118744 A3
		appd	R.BIAN 2011-07-20		type Product Customer Drawing
sheet index	revision sheet				



FCIconnect.com

Copyright FCI



Компания «ЭлектроПласт» предлагает заключение долгосрочных отношений при поставках импортных электронных компонентов на взаимовыгодных условиях!

Наши преимущества:

- Оперативные поставки широкого спектра электронных компонентов отечественного и импортного производства напрямую от производителей и с крупнейших мировых складов;
- Поставка более 17-ти миллионов наименований электронных компонентов;
- Поставка сложных, дефицитных, либо снятых с производства позиций;
- Оперативные сроки поставки под заказ (от 5 рабочих дней);
- Экспресс доставка в любую точку России;
- Техническая поддержка проекта, помощь в подборе аналогов, поставка прототипов;
- Система менеджмента качества сертифицирована по Международному стандарту ISO 9001;
- Лицензия ФСБ на осуществление работ с использованием сведений, составляющих государственную тайну;
- Поставка специализированных компонентов (Xilinx, Altera, Analog Devices, Intersil, Interpoint, Microsemi, Aeroflex, Peregrine, Syfer, Eurofarad, Texas Instrument, Miteq, Cobham, E2V, MA-COM, Hittite, Mini-Circuits, General Dynamics и др.);

Помимо этого, одним из направлений компании «ЭлектроПласт» является направление «Источники питания». Мы предлагаем Вам помощь Конструкторского отдела:

- Подбор оптимального решения, техническое обоснование при выборе компонента;
- Подбор аналогов;
- Консультации по применению компонента;
- Поставка образцов и прототипов;
- Техническая поддержка проекта;
- Защита от снятия компонента с производства.



Как с нами связаться

Телефон: 8 (812) 309 58 32 (многоканальный)

Факс: 8 (812) 320-02-42

Электронная почта: org@eplast1.ru

Адрес: 198099, г. Санкт-Петербург, ул. Калинина, дом 2, корпус 4, литера А.