

PRODUCT NUMBER
SEE TABLE

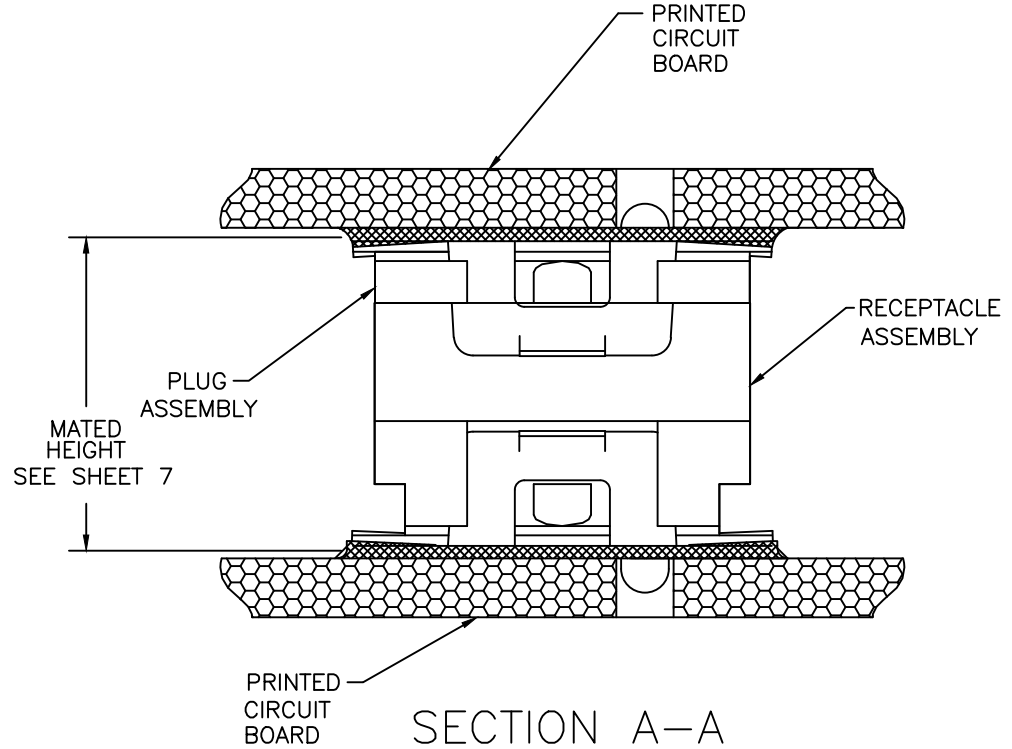

SECTION A-A
ROTATED 90°
N.T.S.

| | | | | | | | | | |
|-------------|-------------|---------------------|------------|---------------------------------------|--------|-------------------------|---|---------------------------|--|
| mat'l. code | | surface ISO 1302 | | tolerance ISO 406 ISO 1101 | | projection | | product family CONAN® | |
| ltr | ecn no | dr | date | tolerances unless otherwise specified | | INCH/MM | | title | |
| A | N11-0214 | J.Z | 2011-07-20 | angles | linear | .XX±.01/.X±0.3 | | CONAN® CONNECTOR ASSEMBLY | |
| B | ELX-N-05460 | J.Z | 2011-08-23 | | | .XXX±.005/.XXX±0.13 | | dwg no | |
| C | ELX-N-14210 | GM | 2013-03-07 | 0°±2' | | .XXXX±.0020/.XXXX±0.051 | | sheet 1 of 7 size | |
| - | - | - | - | dr | J.ZHOU | 2011-07-20 | | 10118744 | |
| - | - | - | - | enr | J.ZHOU | 2011-07-20 | | A3 | |
| - | - | - | - | chr | J.ZHOU | 2011-07-20 | | type | |
| - | - | - | - | appd | R.BIAN | 2011-07-20 | | Product Customer Drawing | |
| sheet | revision | C | C | C | C | C | C | | |
| index | sheet | 1 | 2 | 3 | 4 | 5 | 6 | 7 | |

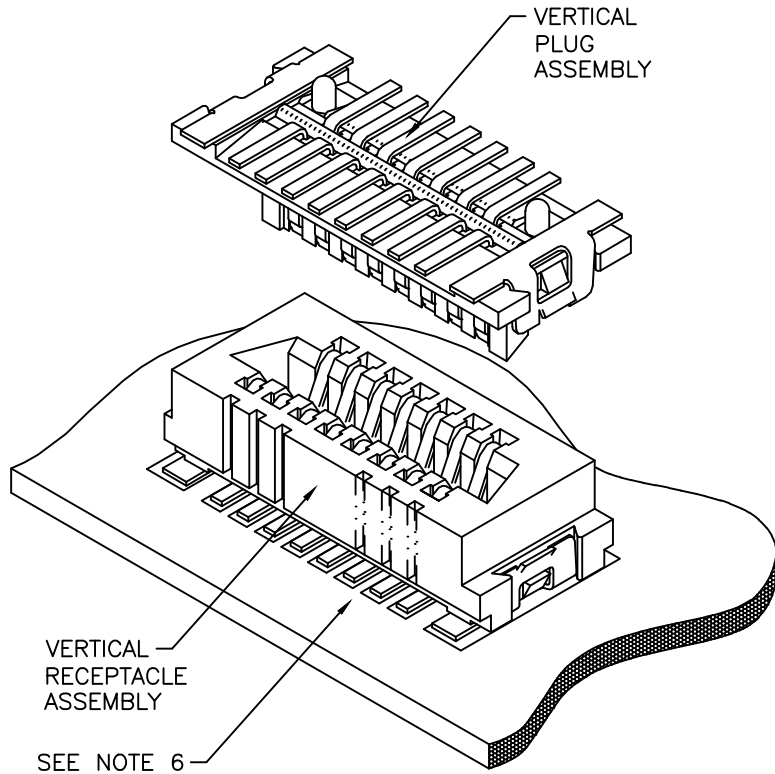

Copyright FCI

PRODUCT NUMBER
SEE TABLE

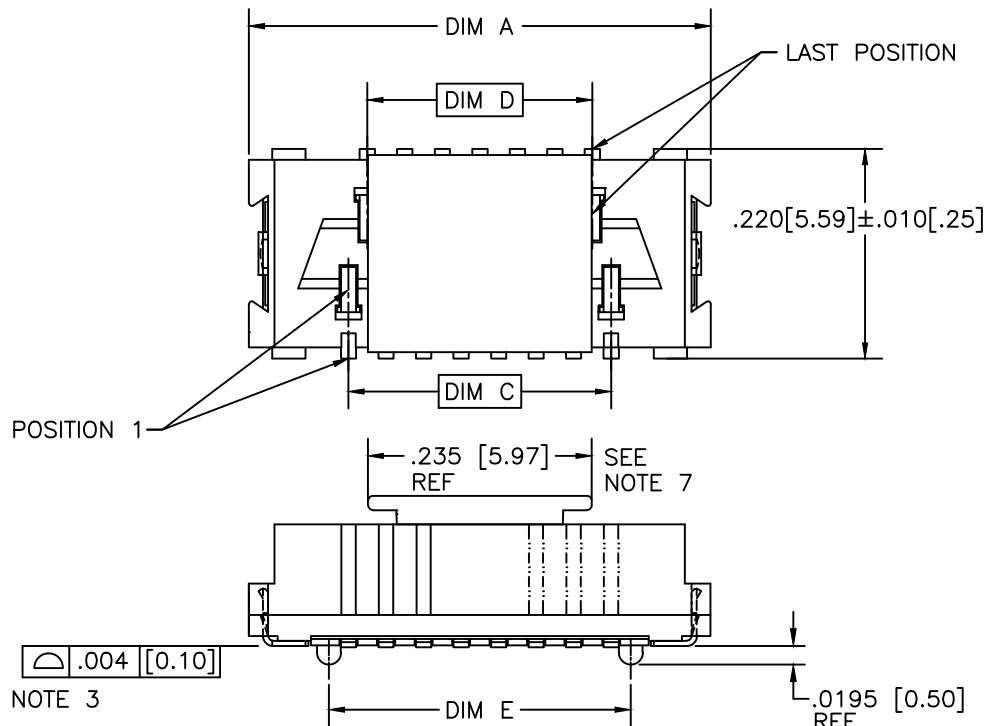

RECEPTACLE

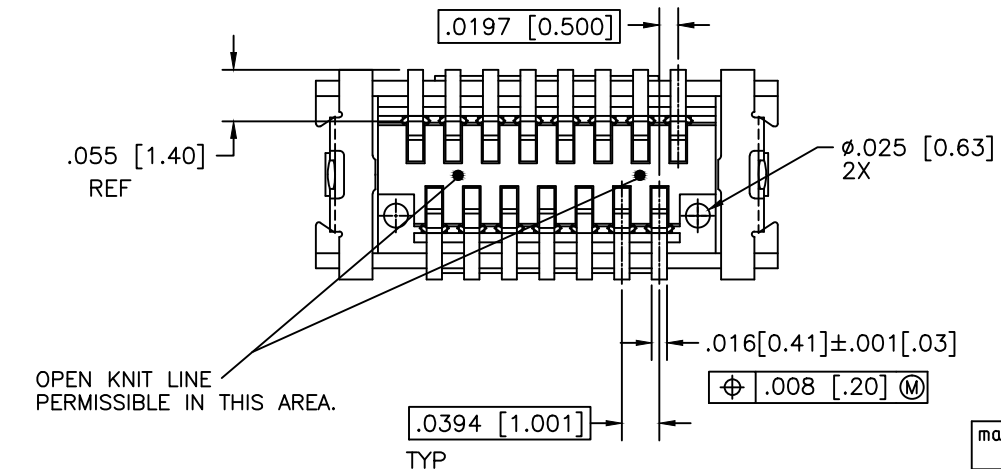
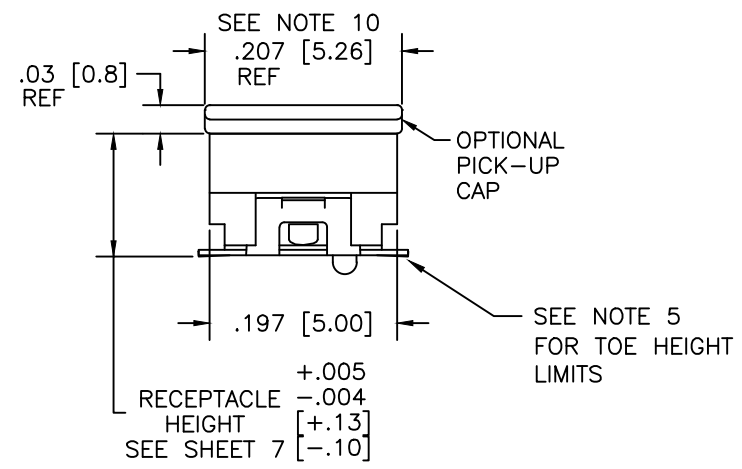

| | | | | | |
|-------------|----------------|-----------------------|----------------------------------|---|------------------------------------|
| mat'l. code | | surface ISO 1302 ✓ | tolerance ISO 406 ISO 1101 | projection INCH/MM | product family CONAN® |
| ltr | ecn no | dr | date | tolerances unless otherwise specified | title CONAN® CONNECTOR ASSEMBLY |
| c | | | | linear XX±.01/XX±0.3 XXX±.005/XXX±0.13 XXXX±.0020/XXXX±0.051 | dwg no 10118744 |
| | | | | 0°±2' | sheet 2 of 7 size A3 |
| | | dr | J.ZHOU | 2011-07-20 | FCI |
| | | enr | J.ZHOU | 2011-07-20 | |
| | | chr | J.ZHOU | 2011-07-20 | |
| | | appd | R.BIAN | 2011-07-20 | |
| sheet index | revision sheet | | | | type Product Customer Drawing |

PRODUCT NUMBER
SEE TABLE

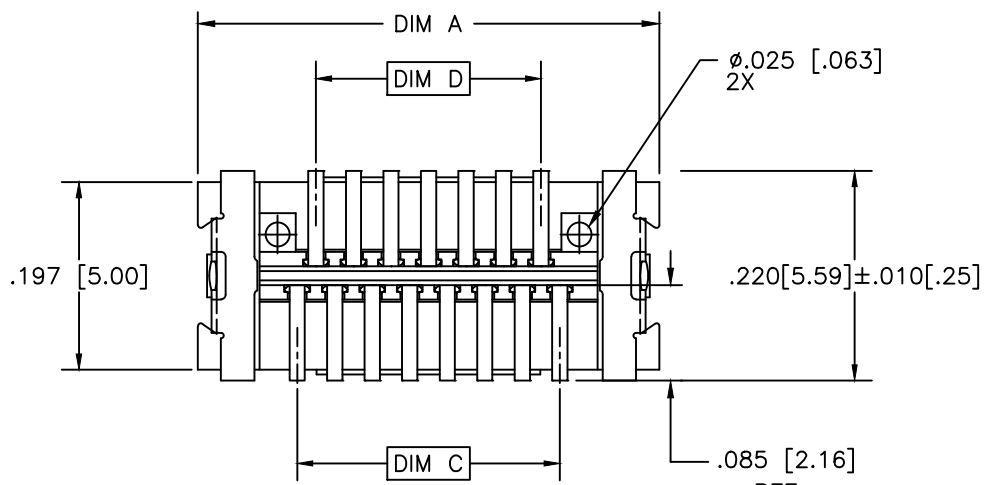

PLUG

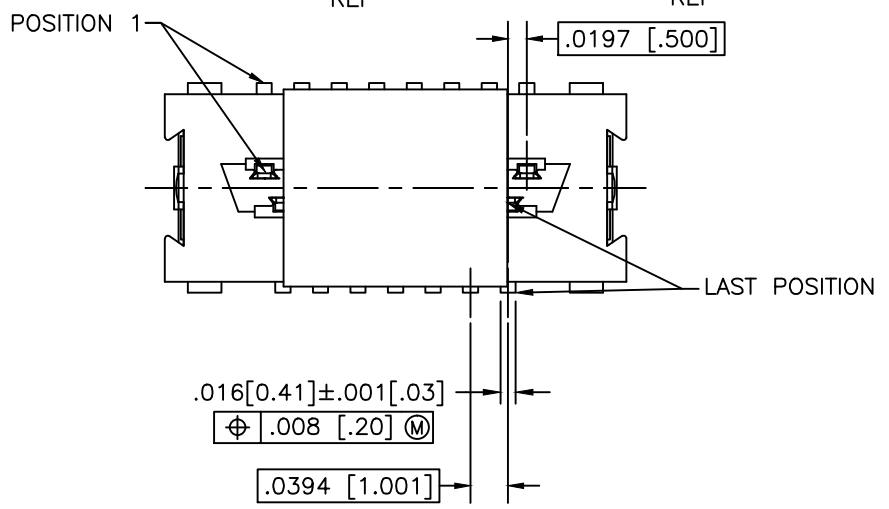
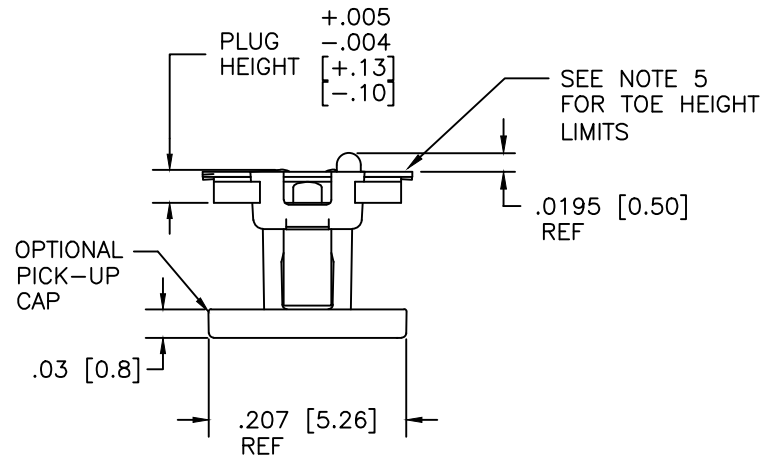
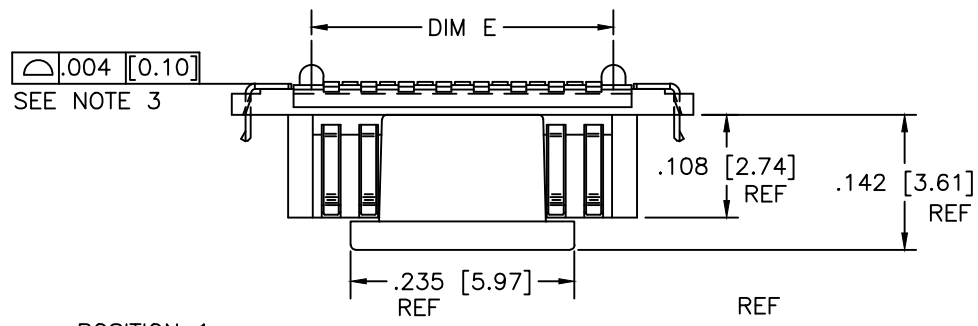

| | | | | | |
|-------------|----------------|---------------------|----------------------------------|---|--|
| mat'l. code | | surface ISO 1302 | tolerance ISO 406 ISO 1101 | projection | product family CONAN [®] |
| ltr | ecn no | dr | date | tolerances unless otherwise specified | title |
| c | | | | linear XX±.01/XX±0.3 XXX±.005/XXX±0.13 XXXX±.0020/XXXX±0.051 | CONAN [®] CONNECTOR ASSEMBLY |
| | | | | angles 0°±2' | INCH/MM |
| | | | | dr | scale 5:1 |
| | | | | enr | |
| | | | | chr | |
| | | | | appd | |
| sheet index | revision sheet | | | | product family CONAN [®] |
| | | | | | title CONAN [®] CONNECTOR ASSEMBLY |
| | | | | | dwg no 10118744 |
| | | | | | sheet 4 of 7 size A3 |
| | | | | | type Product Customer Drawing |

PRODUCT NUMBER
SEE TABLE

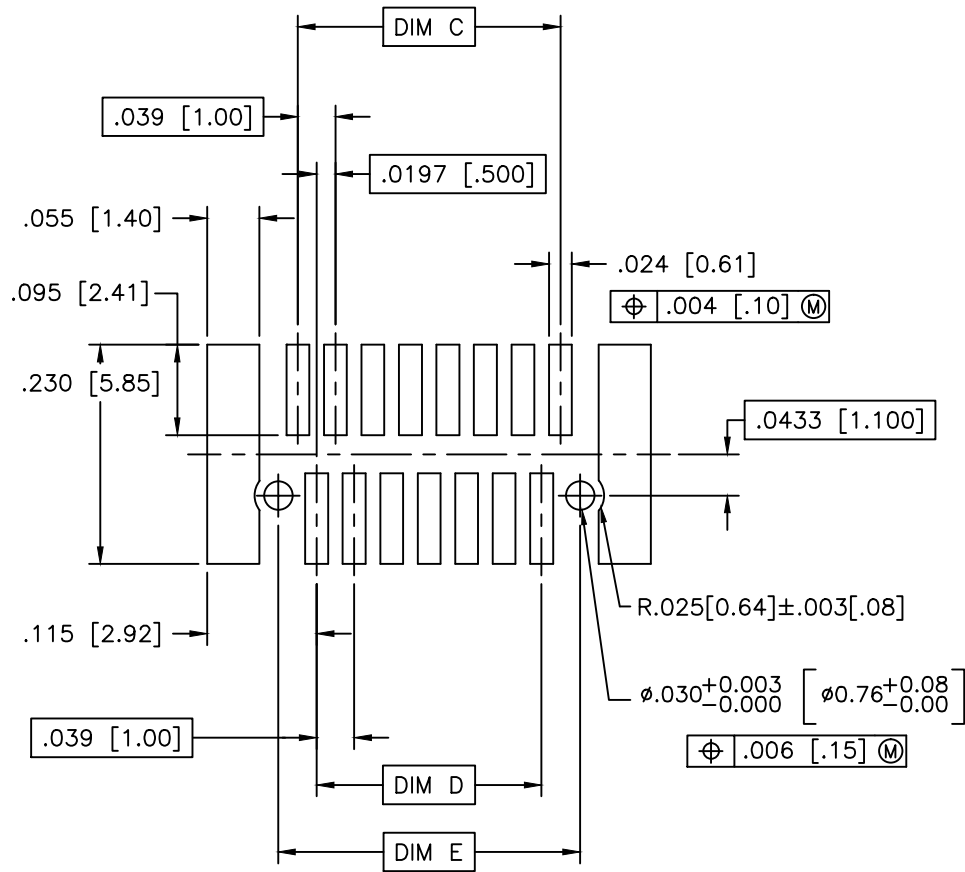

RECOMMENDED
PAD LAYOUT
FOR PLUG

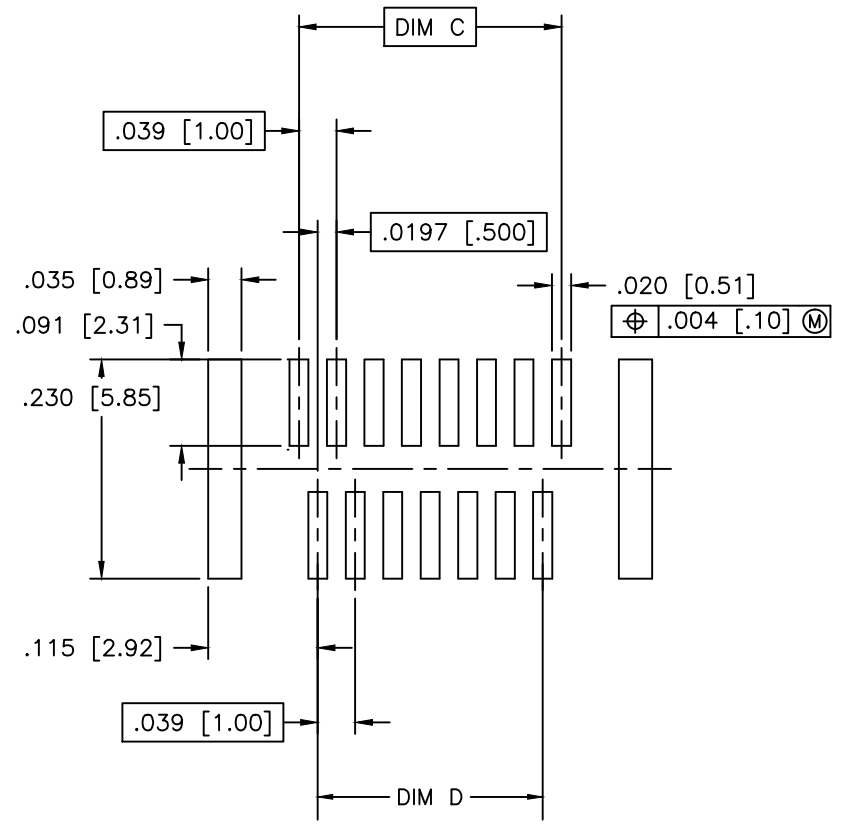

RECOMMENDED
STENCIL LAYOUT
FOR PLUG

| | | | | | | |
|-------------|----------------|-----------------------|----------------------------------|---------------------------------------|--|---------------------------|
| mat'l. code | | surface ISO 1302 ✓ | tolerance ISO 406 ISO 1101 | projection INCH/MM | product family CONAN® | |
| ltr | ecn no | dr | date | tolerances unless otherwise specified | | title |
| c | | | | angles | linear | CONAN® CONNECTOR ASSEMBLY |
| | | | | 0°±2' | XXX±.01/XXX.3 XXX±.005/XXX.13 XXX±.0020/XXX±.051 | scale 5:1 |
| | | dr | J.ZHOU | 2011-07-20 | dwg no | |
| | | enr | J.ZHOU | 2011-07-20 | sheet 5 of 7 size | |
| | | chr | J.ZHOU | 2011-07-20 | 10118744 A3 | |
| | | appd | R.BIAN | 2011-07-20 | type Product Customer Drawing | |
| sheet index | revision sheet | | | | | |

| PRODUCT NUMBER | POS | DIM "A" | DIM "C" | DIM "D" | DIM "E" |
|--------------------|-----|---------------|---------------|---------------|-----------------|
| 10118744-TCWXY09LF | 9 | .366 [9.30] | .157 [4.00] | .118 [3.00] | .1990 [5.055] |
| -TCWXY11LF | 11 | .406 [10.30] | .197 [5.00] | .157 [4.00] | .2380 [6.045] |
| -TCWXY15LF | 15 | .484 [12.30] | .276 [7.00] | .236 [6.00] | .3170 [8.052] |
| -TCWXY21LF | 21 | .602 [15.30] | .394 [10.00] | .354 [9.00] | .4350 [11.049] |
| -TCWXY25LF | 25 | .681 [17.30] | .472 [12.00] | .433 [11.00] | .5140 [13.056] |
| -TCWXY31LF | 31 | .800 [20.30] | .591 [15.00] | .551 [14.00] | .6320 [16.053] |
| -TCWXY41LF | 41 | .996 [25.30] | .787 [20.00] | .748 [19.00] | .8290 [21.057] |
| -TCWXY51LF | 51 | 1.193 [30.30] | .984 [25.00] | .945 [24.00] | 1.0260 [26.060] |
| -TCWXY69LF | 69 | 1.547 [39.30] | 1.339 [34.00] | 1.299 [33.00] | 1.3800 [35.052] |

NOTES:

1. MATERIALS:

RECEPTACLE HOUSING - LCP, UL-94V-0. COLOR: NATURAL.

RECEPTACLE TERMINALS - COPPER ALLOY, PLATED WITH GOLD OR GXT IN CONTACT AREA AND 100u"/2.54u Sn ON SOLDER LEGS WITH AN OVERALL 50u"/1.27u Ni UNDERPLATE.

PLUG HOUSING - LCP, UL-94V-0. COLOR: NATURAL.

PLUG TERMINALS - COPPER ALLOY, PLATED WITH GOLD OR GXT IN CONTACT AREA AND 100u"/2.54u Sn ON SOLDER LEGS WITH AN OVERALL 50u"/1.27u Ni UNDERPLATE.

RETENTION DEVICE - BRASS, PLATED WITH 100u"/2.54u Sn OVER NICKEL.

2. REFERENCE GS-12-0977 FOR PRODUCT PERFORMANCE AND ENVIRONMENTAL RESISTANCE DATA.

3. SEE TA-774 FOR FURTHER DESCRIPTION OF HOW THIS DIMENSION IS APPLIED.

4. RECOMMENDED SOLDER PASTE THICKNESS IS .006 TO .008 INCHES THICK.

5. THE TOE HEIGHT OF THE SOLDER TAIL SHALL BE MEASURED FROM THE LOWEST POINT OF THE .004 CO-PLANARITY GRAVITY PLANE. THIS MEASUREMENT IS NOT TO EXCEED A WINDOW OF .000 TO .007 INCHES.

6. THREE SLOTS MAY BE LOCATED AT EITHER END OF HOUSING.

7. THE HOUSING WILL WITHSTAND EXPOSURE TO 260°C PEAK TEMPERATURE FOR 30 SECONDS IN A CONVECTION INFRA RED OR VAPOR PHASE REFLOW OVEN. SEE APPLICATION/PROCEDURES IF THEY ARE AVAILABLE

8. PRODUCT WITH "LF" AT THE END MEETS EUROPEAN UNION DIRECTIVES AND OTHER COUNTRY REGULATION AS DESCRIBED IN GS-22-008.



Copyright FCI

| | | | | | |
|-------------|----------------|---------------------|----------------------------------|--|--------------------------------------|
| mat'l. code | | surface ISO 1302 | tolerance ISO 406 ISO 1101 | projection | product family CONAN® |
| ltr | ecn no | dr | date | tolerances unless otherwise specified | title |
| c | | | | linear XXX±.01/XX±0.3 XXX±.005/XX±0.13 XXX±.0020/XX±0.051 | CONAN® CONNECTOR ASSEMBLY |
| | | | | angles 0°±2' | INCH/MM |
| | | | | dr | scale 5:1 |
| | | | | enr | J.ZHOU 2011-07-20 |
| | | | | chr | J.ZHOU 2011-07-20 |
| | | | | appd | R.BIAN 2011-07-20 |
| sheet index | revision sheet | | | | FCI |
| | | | | | dwg no 10118744 sheet 6 of 7 size A3 |
| | | | | | type Product Customer Drawing |

PRODUCT NUMBER
SEE TABLE

CONAN® ASSEMBLY PART NUMBER

10118744 - T C W 3 Y ZZ LF

LEAD FREE
SEE NOTE 8

| TYPE | T |
|----------------------|---|
| PLUG WITH PEGS | 1 |
| RECEPTACLE WITH PEGS | 3 |

| Y | PLUG HEIGHT | RECEPTACLE HEIGHT | MATED HEIGHT +.010 -.008 [+.25] [-.20] |
|---|---------------|-----------------------------------|--|
| 1 | .034 [.86] | .129 [3.28] | .163 [4.15] |
| 2 | .048 [1.23] | SEE Y=1 FOR ALL RECEPTACLES | .177 [4.50] |
| 3 | .068 [1.73] | | .197 [5.00] |
| 4 | .107 [2.72] | | .236 [6.00] |
| 5 | .1465 [3.721] | | .276 [7.00] |

| ZZ | NUMBER OF POSITIONS |
|----|---------------------|
| 09 | 9 |
| 11 | 11 |
| 15 | 15 |
| 21 | 21 |
| 25 | 25 |
| 31 | 31 |
| 41 | 41 |
| 51 | 51 |
| 69 | 69 |

| | |
|----------------------------|---|
| PICK AND PLACE CAP OR TAPE | C |
| WITH CAP | 1 |

| | |
|-----------------------------|---|
| PACKAGING | W |
| PRESSURE SEALED TAPE & REEL | 3 |

EXAMPLE: 10118744-3131125LF
IS A CONAN® RECEPTACLE ASSEMBLY,
HAVING PEGS AND WITH A PICK AND PLACE CAP.
IT IS .13 [3.2] HIGH AND 25 POSITIONS AND IS
PACKAGED IN PRESSURE SEALED TAPE, REEL AND LEAD FREE.

| | | | | | |
|-------------|----------------|-----------------------|----------------------------------|---|-------------------------------|
| mat'l. code | | surface ISO 1302 ✓ | tolerance ISO 406 ISO 1101 | projection | product family CONAN® |
| ltr | ecn no | dr | date | tolerances unless otherwise specified | title |
| C | | | | linear XXX±.01/XXX.3 XXX±.005/XXX.13 XXX±.0020/XXX±0.051 | CONAN® CONNECTOR ASSEMBLY |
| | | | | angles 0°±2' | INCH/MM scale 5:1 |
| | | dr | J.ZHOU | 2011-07-20 | dwg no |
| | | enr | J.ZHOU | 2011-07-20 | sheet 7 of 7 |
| | | chr | J.ZHOU | 2011-07-20 | size |
| | | appd | R.BIAN | 2011-07-20 | 10118744 |
| | | | | | A3 |
| | | | | | type Product Customer Drawing |
| sheet index | revision sheet | | | | |



Компания «ЭлектроПласт» предлагает заключение долгосрочных отношений при поставках импортных электронных компонентов на взаимовыгодных условиях!

Наши преимущества:

- Оперативные поставки широкого спектра электронных компонентов отечественного и импортного производства напрямую от производителей и с крупнейших мировых складов;
- Поставка более 17-ти миллионов наименований электронных компонентов;
- Поставка сложных, дефицитных, либо снятых с производства позиций;
- Оперативные сроки поставки под заказ (от 5 рабочих дней);
- Экспресс доставка в любую точку России;
- Техническая поддержка проекта, помощь в подборе аналогов, поставка прототипов;
- Система менеджмента качества сертифицирована по Международному стандарту ISO 9001;
- Лицензия ФСБ на осуществление работ с использованием сведений, составляющих государственную тайну;
- Поставка специализированных компонентов (Xilinx, Altera, Analog Devices, Intersil, Interpoint, Microsemi, Aeroflex, Peregrine, Syfer, Eurofarad, Texas Instrument, Miteq, Cobham, E2V, MA-COM, Hittite, Mini-Circuits, General Dynamics и др.);

Помимо этого, одним из направлений компании «ЭлектроПласт» является направление «Источники питания». Мы предлагаем Вам помощь Конструкторского отдела:

- Подбор оптимального решения, техническое обоснование при выборе компонента;
- Подбор аналогов;
- Консультации по применению компонента;
- Поставка образцов и прототипов;
- Техническая поддержка проекта;
- Защита от снятия компонента с производства.



Как с нами связаться

Телефон: 8 (812) 309 58 32 (многоканальный)

Факс: 8 (812) 320-02-42

Электронная почта: org@eplast1.ru

Адрес: 198099, г. Санкт-Петербург, ул. Калинина, дом 2, корпус 4, литера А.