

THIS DRAWING IS UNPUBLISHED. RELEASED FOR PUBLICATION  
 © COPYRIGHT - By - ALL RIGHTS RESERVED.

LOC		DIST		REVISIONS			
P	LTR	DESCRIPTION		DATE	DWN	APVD	
AD	00	B2	REVISED PER ECO-11-004587		11MAR11	RK	HMR

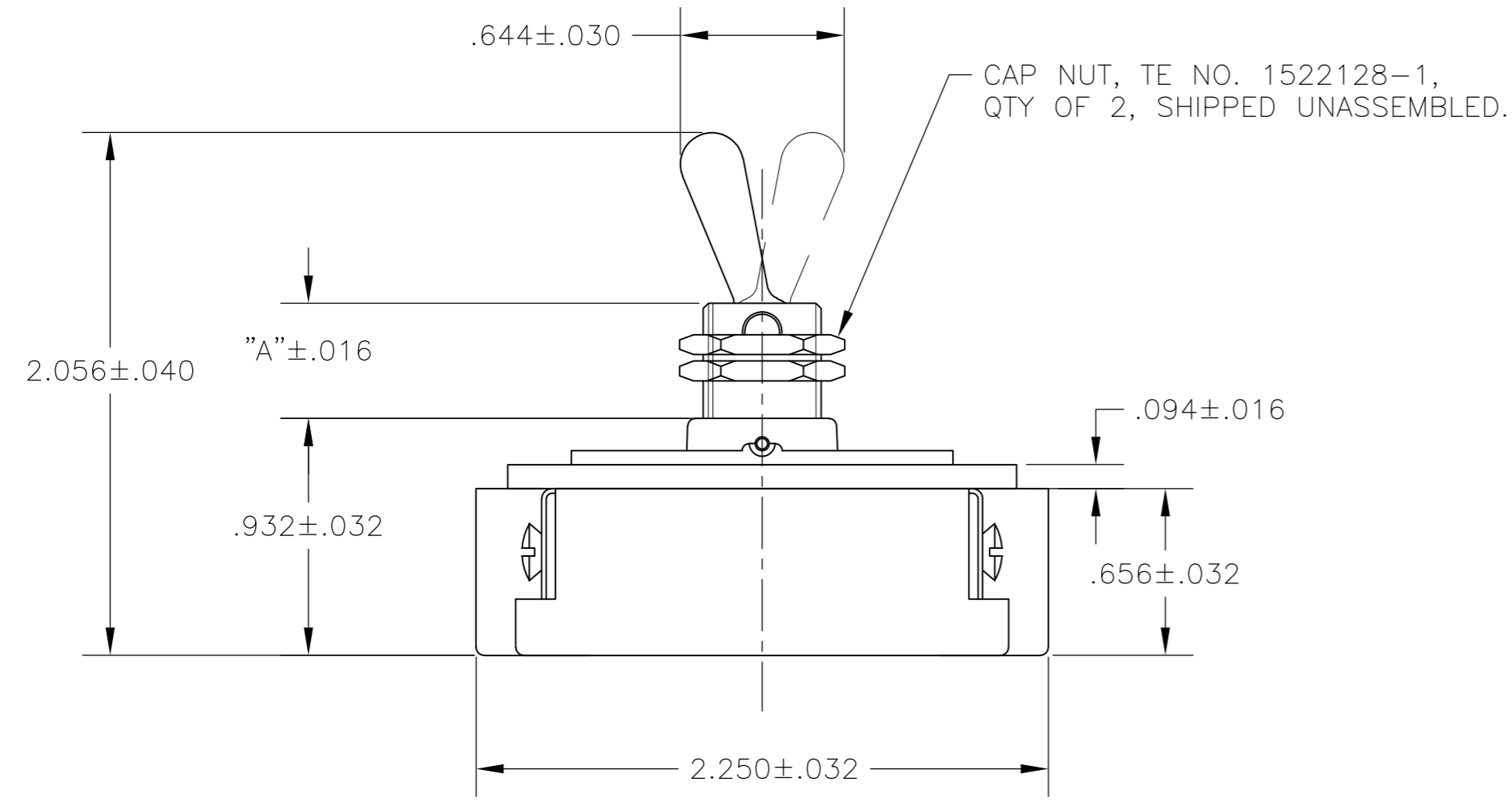

6-32 X .250 LONG UNDERCUT BDG. HD. SCREW, PART NO. 1523927-1. SWITCHES 1520228-1, 1520228-2, 1520228-3, 1-1520228-1, 2-1520228-3, 2-1520228-4, 6520228-1, 6520228-2, 6520228-3, 1-6520228-1, 2-6520228-3, 2-6520228-4: QTY OF 4, SHIPPED UNASSEMBLED. SWITCH 1-1520228-0, 1-6520228-0 ONLY: QTY OF 4, SHIPPED ASSEMBLED.

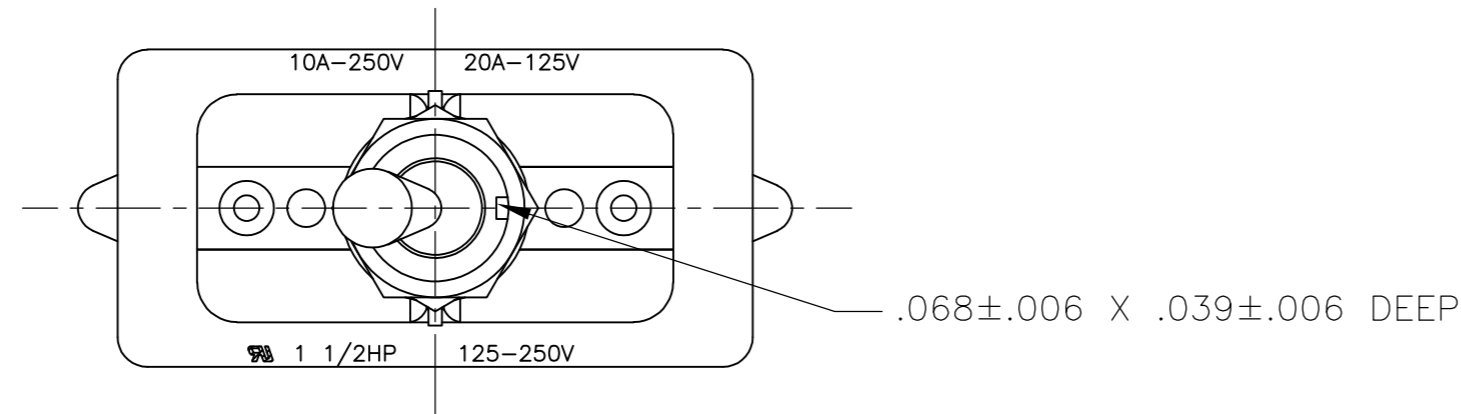
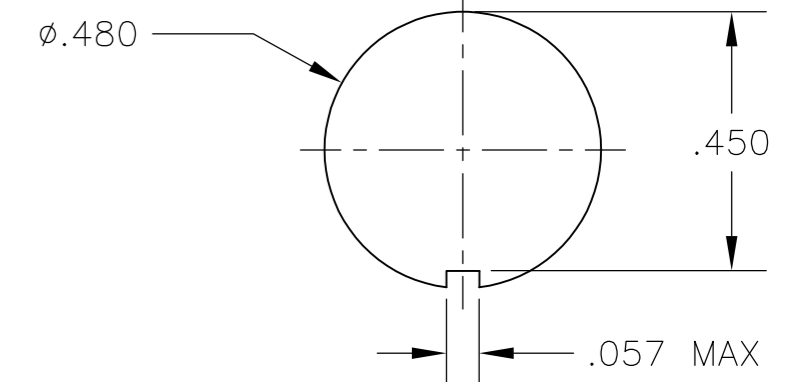
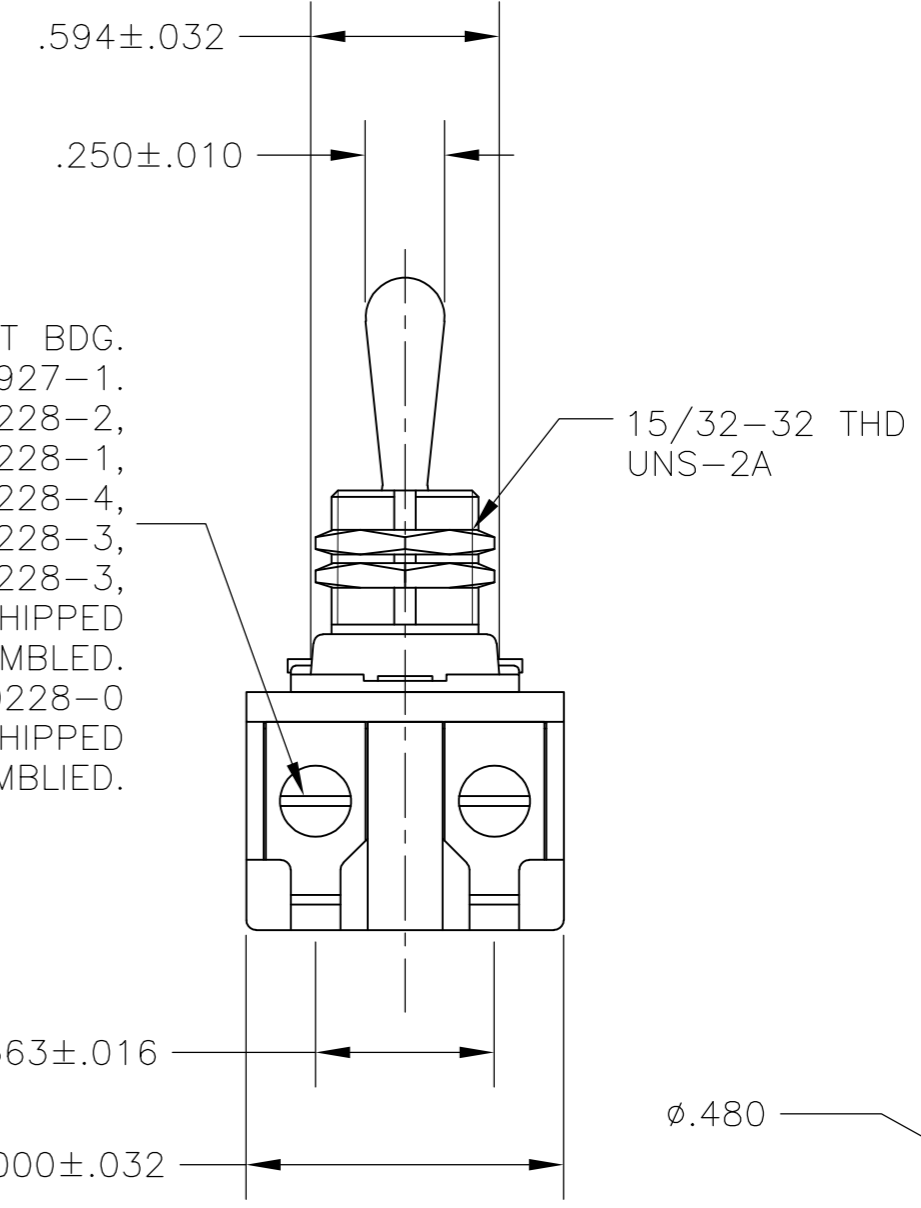

RECOMMENDED PANEL CUTOUT DIMENSIONS SCALE 3:1

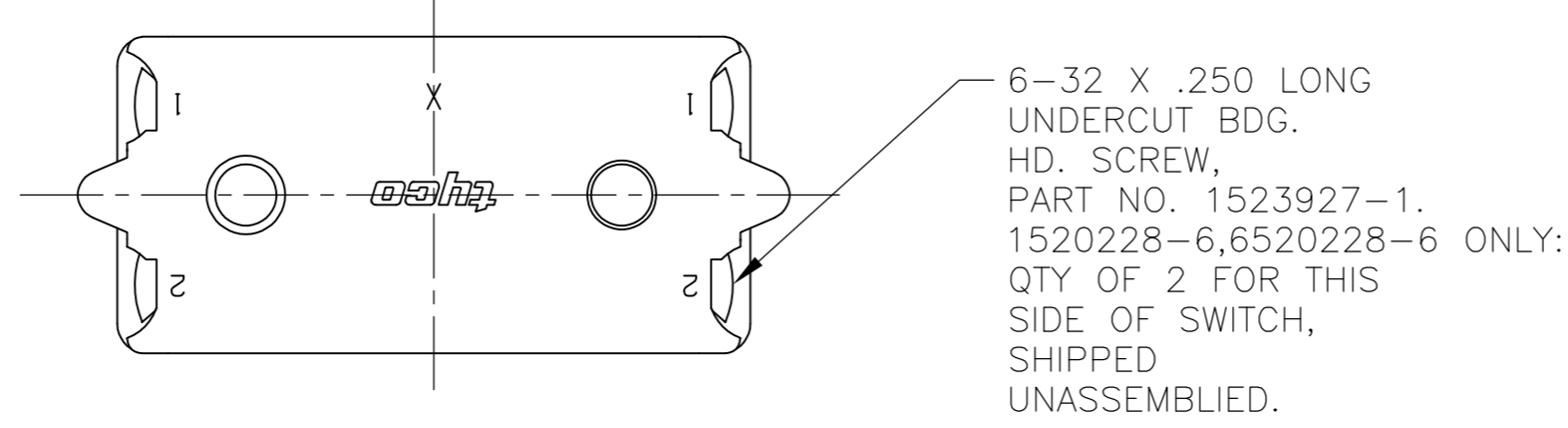

- 1 T-PAK - SWITCH AND HARDWARE INDIVIDUALLY PACKED IN PLASTIC BAGS BEFORE BEING PLACED IN A INTERMEDIATE BOX WHICH IS THEN PLACED IN A SHIPPING BOX. SEE TABLE.
- 2 P/N X-6520228-X IS ROHS COMPLIANT.
- 3 MOUNTING DIMENSIONS FOR REFERENCE ONLY.

2-1520228-4/2-6520228-4	7360K8 T-PAK	15/32" THD LENGTH DIE CAST	.469	DPST
2-1520228-3/2-6520228-3	7360K7 T-PAK	11/32" THD LENGTH DIE CAST	.344	DPST
1-1520228-1/1-6520228-1	8910K219	15/32" THD LENGTH DIE CAST	.469	DPST
1-1520228-0/1-6520228-0	8910K205	11/32" THD LENGTH DIE CAST	.344	DPST
1520228-6/6520228-6	7362K4	15/32" THD LENGTH DIE CAST	.469	SPST WITH BUSSING
1520228-3/6520228-3	7360K7	11/32" THD LENGTH DIE CAST	.344	DPST
1520228-2/6520228-2	7359K3	15/32" THD LENGTH DIE CAST	.469	DPST
1520228-1/6520228-1	7359K2	11/32" THD LENGTH DIE CAST	.344	DPST
PART NO.	ARAB NO.	BUSHING / PLATE ASSY	A	DESCRIPTION

90-345

THIS DRAWING IS A CONTROLLED DOCUMENT.		DWN	26SEP02	<b>TE</b> TE Connectivity	
DIMENSIONS: INCHES		CHK	-		
TOLERANCES UNLESS OTHERWISE SPECIFIED:		APVD	-	NAME	
0 PLC	± -	PRODUCT SPEC		20 AMP 125V AC/DC, 10 AMP 250V AC/DC, 1 1/2 HP 125V/250V AC/DC, ONE HOLE MOUNTING TOOL HANDLE TOGGLE SWITCH	
1 PLC	± -	APPLICATION SPEC		SIZE	A2
2 PLC	± -	WEIGHT		CAGE CODE	00779
3 PLC	± -	CUSTOMER DRAWING		DRAWING NO	1520228
4 PLC	± -	SCALE		RESTRICTED TO	-
ANGLES	± -	SHEET		1 of 4	
FINISH	-	REV		B2	

THIS DRAWING IS UNPUBLISHED. RELEASED FOR PUBLICATION  
 © COPYRIGHT - By - ALL RIGHTS RESERVED.

LOC		DIST		REVISIONS			
P	LTR	DESCRIPTION		DATE	DWN	APVD	
AD	00	SEE SHEET 1		-	-	-	

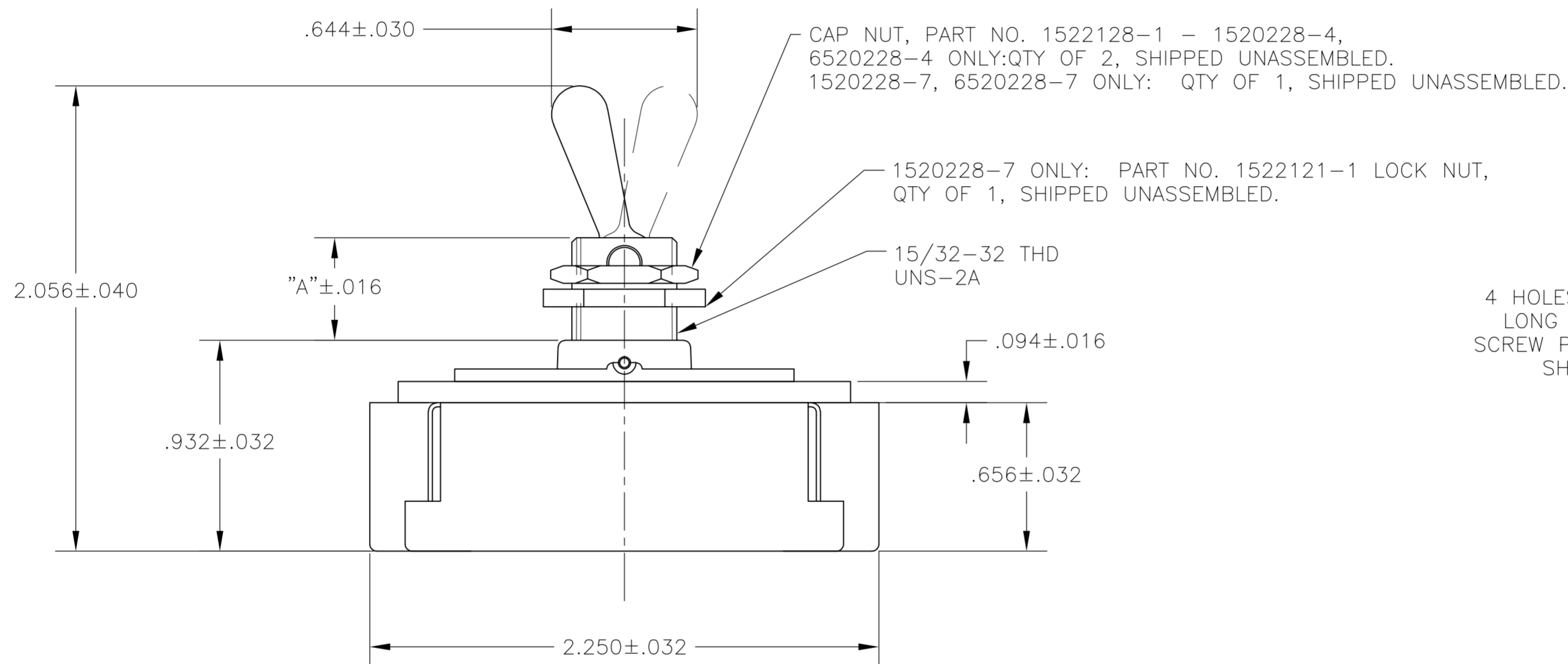
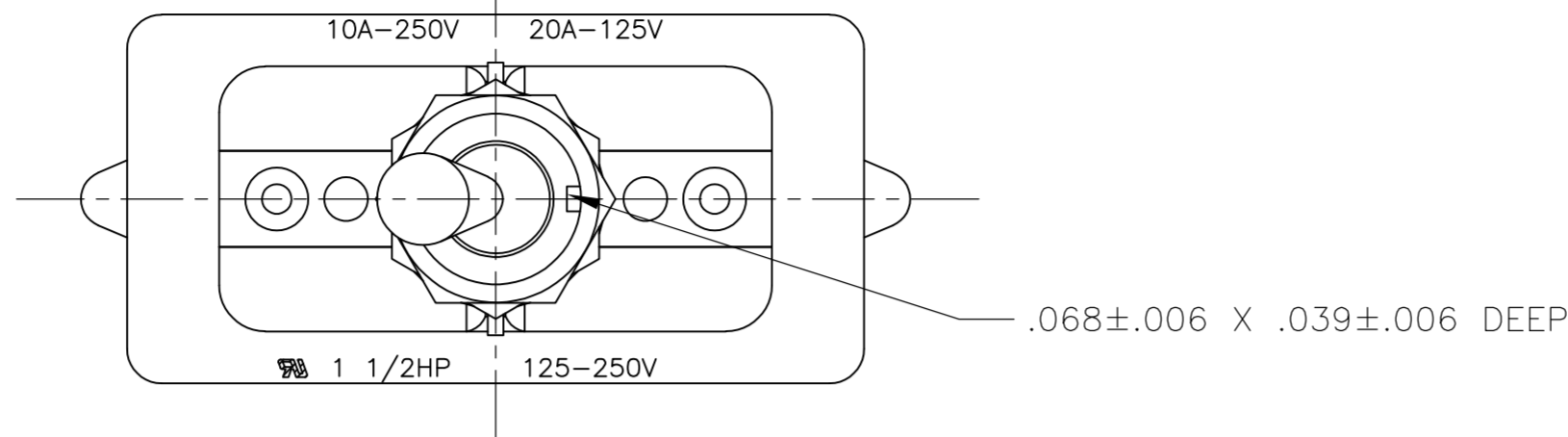

4 HOLES FOR 6-32 X .250  
 LONG UNDERCUT BDG. HD.  
 SCREW PART NO. 1523927-1  
 SHIPPED UNASSEMBLED

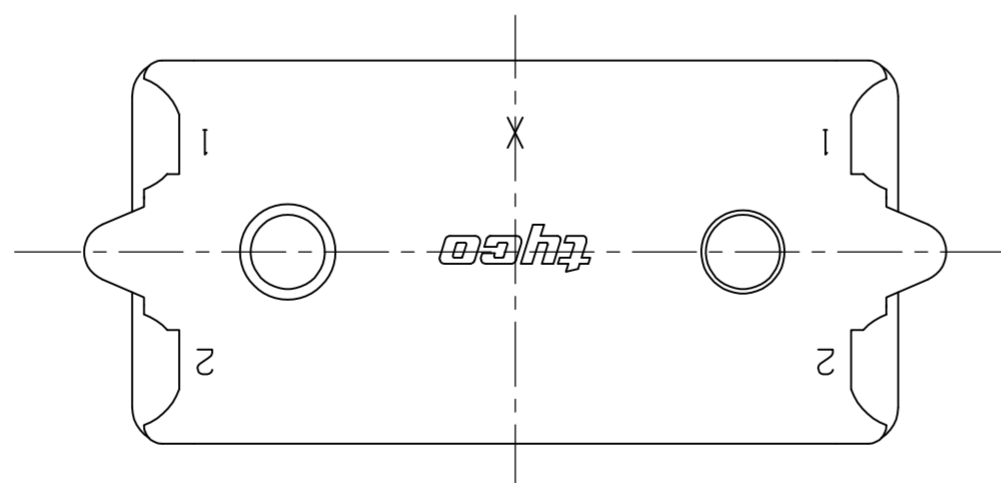
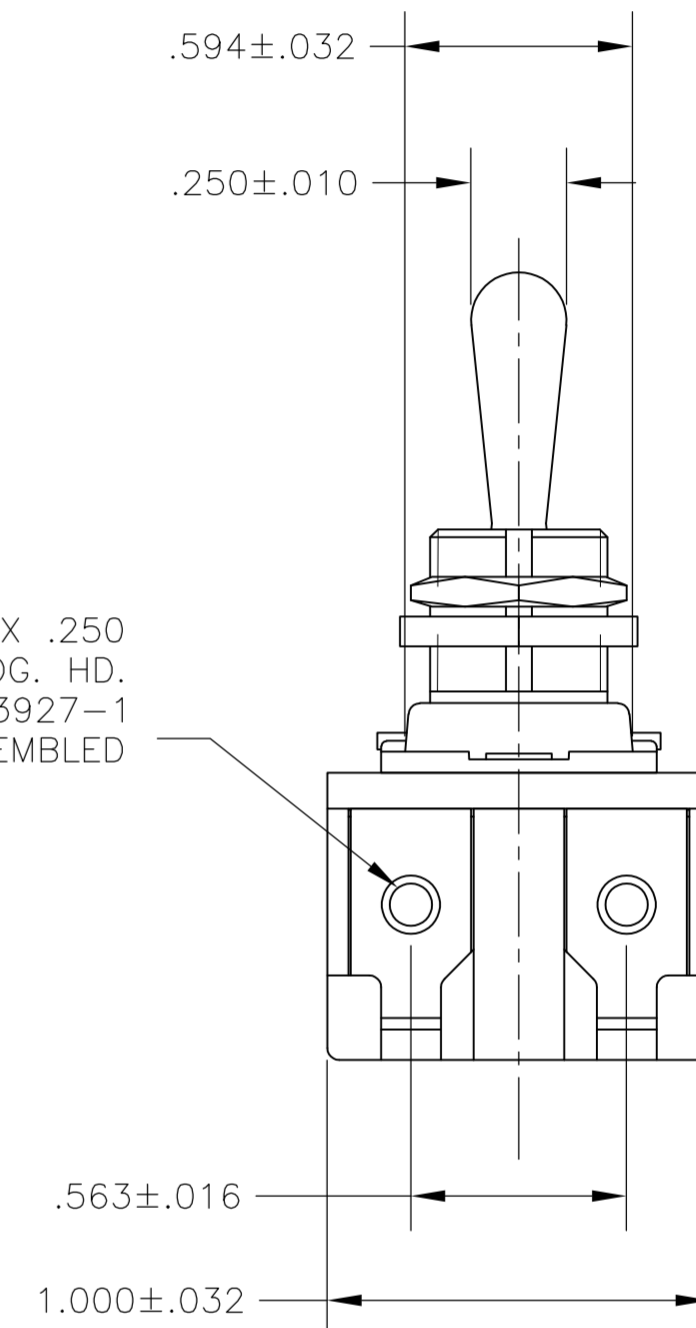

- 1 T-PAK - SWITCH AND HARDWARE INDIVIDUALLY PACKED IN PLASTIC BAGS BEFORE BEING PLACED IN AN INTERMEDIATE BOX WHICH IS THEN PLACED IN A SHIPPING BOX. SEE TABLE.
- 2 P/N X-6520228-X IS ROHS COMPLIANT.
- 3 MOUNTING DIMENSIONS FOR REFERENCE ONLY.

91-399

PART NO.	ARAB NO.	BUSHING / PLATE ASSY	A	DESCRIPTION
1520228-7/6520228-7	8909K23	15/32" THD LENGTH DIE CAST	.469	DPST T-PAKED W/SPECIAL HARDWARE
1520228-4/6520228-4	7360K8	15/32" THD LENGTH DIE CAST	.469	DPST

THIS DRAWING IS A CONTROLLED DOCUMENT.		DWN W. HANSON 29APR93	TE Connectivity													
DIMENSIONS: INCHES		CHK W. LeonorD 02MAY93														
TOLERANCES UNLESS OTHERWISE SPECIFIED:		APVD E. WESOLEK 03MAY93	NAME 20 AMP 125V AC/DC, 10 AMP 250V AC/DC, 1 1/2 HP 125V/250V AC/DC, ONE HOLE MOUNTING TOOL HANDLE TOGGLE SWITCH													
<table border="1"> <tr><td>0 PLC</td><td>± -</td></tr> <tr><td>1 PLC</td><td>± -</td></tr> <tr><td>2 PLC</td><td>± -</td></tr> <tr><td>3 PLC</td><td>± -</td></tr> <tr><td>4 PLC</td><td>± -</td></tr> <tr><td>ANGLES</td><td>± -</td></tr> </table>		0 PLC	± -	1 PLC	± -	2 PLC	± -	3 PLC	± -	4 PLC	± -	ANGLES	± -	PRODUCT SPEC -	SIZE A2	CAGE CODE 00779
0 PLC	± -															
1 PLC	± -															
2 PLC	± -															
3 PLC	± -															
4 PLC	± -															
ANGLES	± -															
MATERIAL -		FINISH -	WEIGHT -	DRAWING NO C=1520228												
CUSTOMER DRAWING			SCALE 2:1	SHEET 2 of 4												

THIS DRAWING IS UNPUBLISHED. RELEASED FOR PUBLICATION  
 © COPYRIGHT - By - ALL RIGHTS RESERVED.

LOC	DIST	REVISIONS					
AD	00	P	LTR	DESCRIPTION	DATE	DWN	APVD
		-	-	SEE SHEET 1	-	-	-

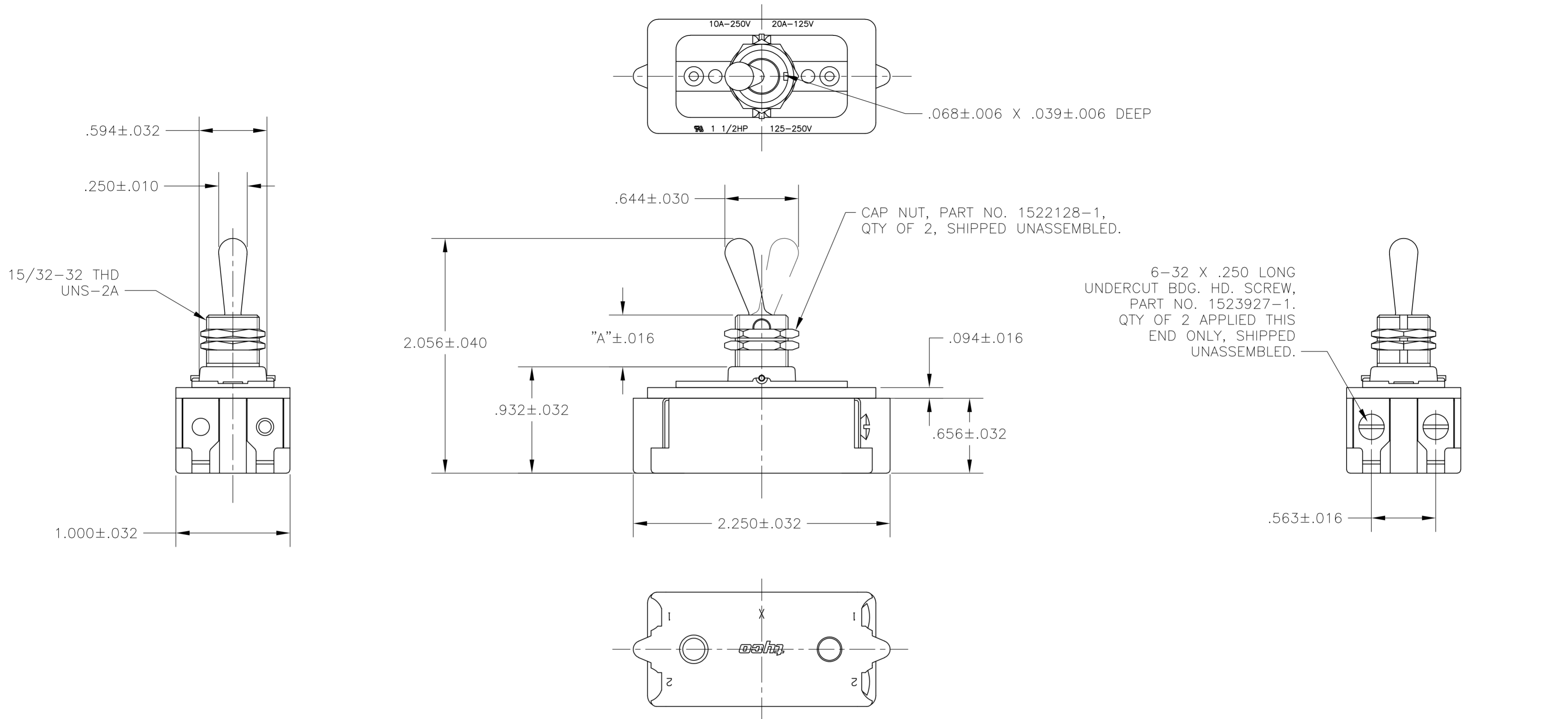

- 1 T-PAK - SWITCH AND HARDWARE INDIVIDUALLY PACKED IN PLASTIC BAGS BEFORE BEING PLACED IN A INTERMEDIATE BOX WHICH IS THEN PLACED IN A SHIPPING BOX. SEE TABLE.
- 2 PLY-O-PAK - SWITCH AND HARDWARE INDIVIDUALLY PACKED IN PLASTIC BAGS BEFORE BEING PACKED LOOSE IN A SHIPPING BOX. SEE TABLE.
- 3 P/N X-6520228-X IS ROHS COMPLIANT.
- 4 MOUNTING DIMENSIONS FOR REFERENCE ONLY.

PART NO.	ARAB NO.	BUSHING / PLATE ASSY	A	DESCRIPTION	
2-1520228-5/2-6520228-5	7361K5	T-PAK	15/32" THD LENGTH DIE CAST	.469	SPST
1520228-9/6520228-9	8910K191		15/32" THD LENGTH DIE CAST	.469	SPST (PLY-O-PAK)
1520228-5/6520228-5	7361K5		15/32" THD LENGTH DIE CAST	.469	SPST

THIS DRAWING IS A CONTROLLED DOCUMENT.

DWN	J. SMITH	13DEC77
CHK	R. GLENN	13DEC77
APVD	M.R. DUMMER	13DEC77

TE Connectivity

NAME: 20 AMP 125V AC/DC, 10 AMP 250V AC/DC, 1 1/2 HP 125V/250V AC/DC, ONE HOLE MOUNTING TOOL HANDLE TOGGLE SWITCH

SIZE	A2	CAGE CODE	00779	DRAWING NO	C=1520228	RESTRICTED TO	-
CUSTOMER DRAWING	SCALE	NTS	SHEET	3 of 4	REV	B2	

THIS DRAWING IS UNPUBLISHED. RELEASED FOR PUBLICATION  
 © COPYRIGHT - By - ALL RIGHTS RESERVED.

LOC	DIST	REVISIONS			
P	LTR	DESCRIPTION	DATE	DWN	APVD
AD	00	SEE SHEET 1	-	-	-

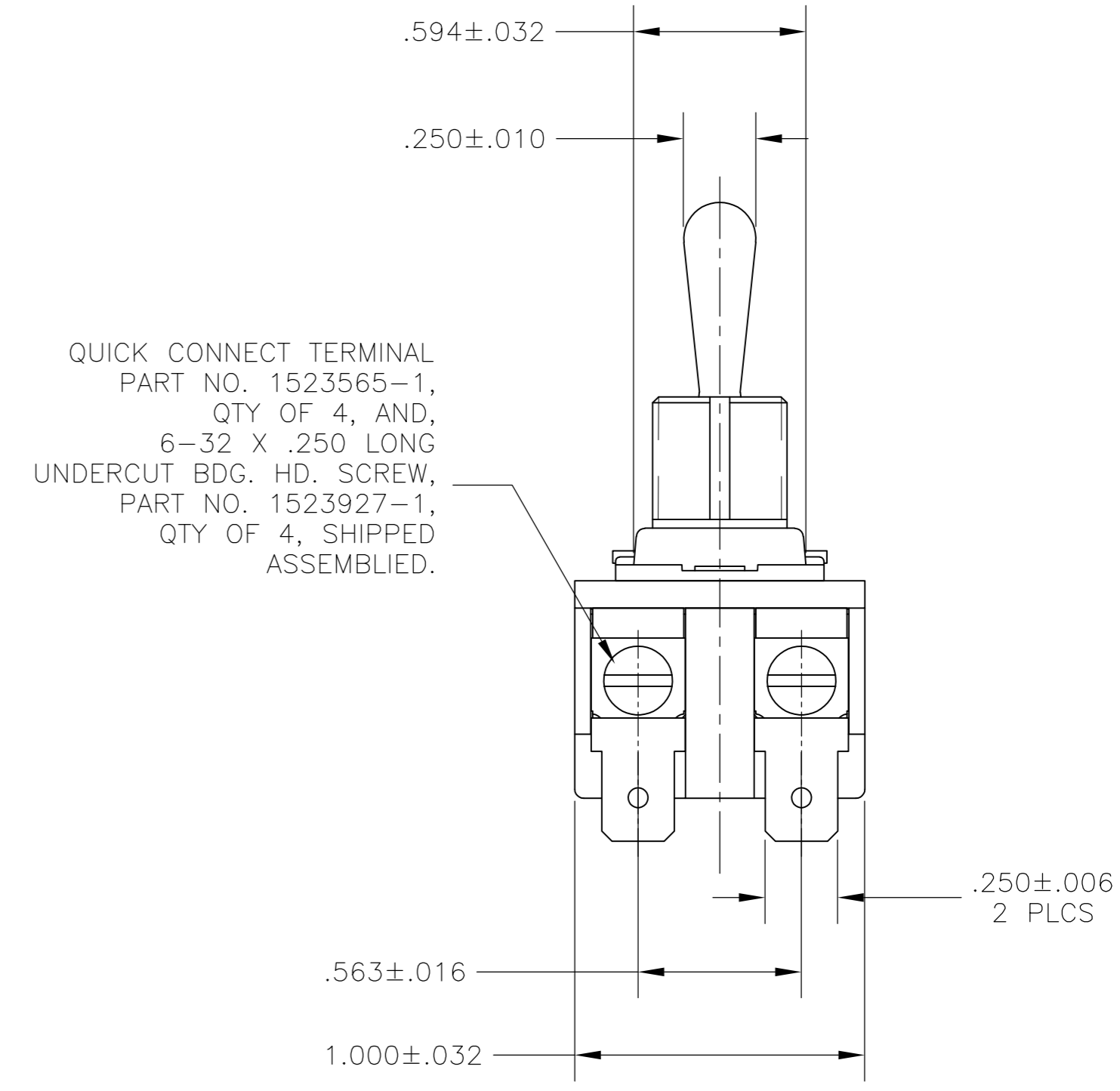
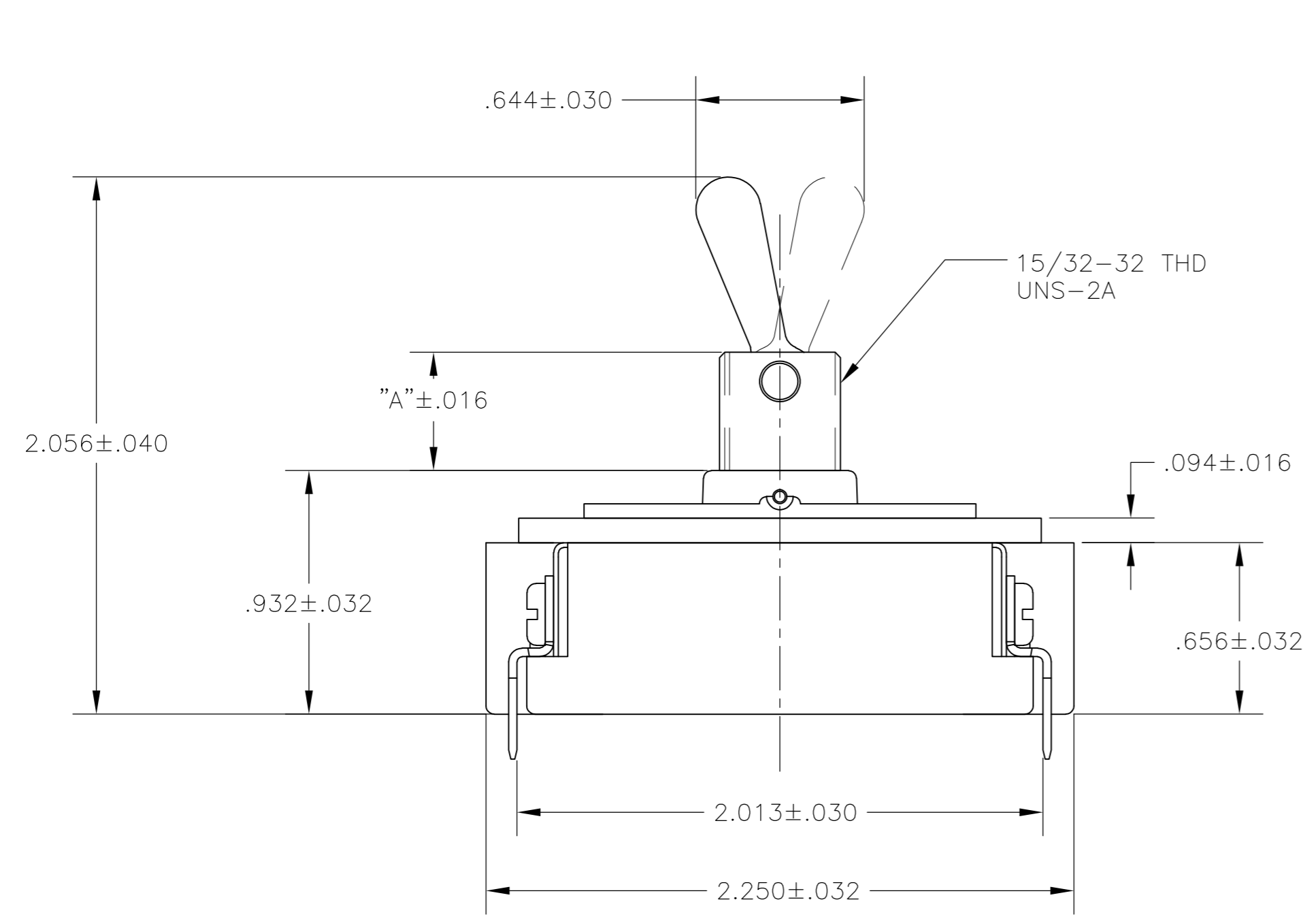
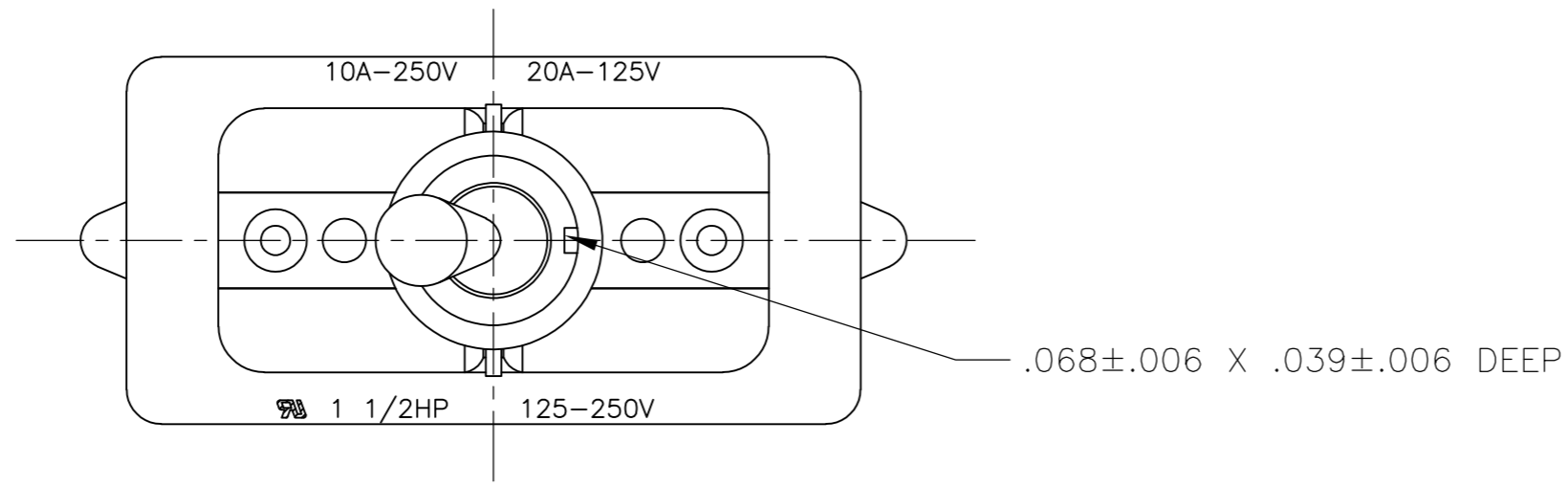

- 1 P/N X-6520228-X IS ROHS COMPLIANT.
- 2 MOUNTING DIMENSIONS FOR REFERENCE ONLY.

91-601

PART NO.	ARAB NO.	BUSHING / PLATE ASSY	A	DESCRIPTION
1520228-8/6520228-8	8910K12	15/32" THD LENGTH DIE CAST	.469	DPST

THIS DRAWING IS A CONTROLLED DOCUMENT.		DWN T.CHRISTENSEN 25OCT95	<b>TE</b> TE Connectivity	
DIMENSIONS: INCHES		CHK W.HANSON 01NOV95		
TOLERANCES UNLESS OTHERWISE SPECIFIED:		APVD M.R.DUMMER 09NOV95	NAME 20 AMP 125V AC/DC, 10 AMP 250V AC/DC, 1 1/2 HP 125V/250V AC/DC, ONE HOLE MOUNTING TOOL HANDLE TOGGLE SWITCH	
0 PLC ± -		PRODUCT SPEC -	SIZE A2	CAGE CODE 00779
1 PLC ± -		APPLICATION SPEC -	DRAWING NO C=1520228	RESTRICTED TO -
2 PLC ± -		WEIGHT -	SCALE 2:1	SHEET 4 of 4
3 PLC ± -		MATERIAL -	REV B2	
4 PLC ± -		FINISH -		
ANGLES ± -		CUSTOMER DRAWING		



Компания «ЭлектроПласт» предлагает заключение долгосрочных отношений при поставках импортных электронных компонентов на взаимовыгодных условиях!

Наши преимущества:

- Оперативные поставки широкого спектра электронных компонентов отечественного и импортного производства напрямую от производителей и с крупнейших мировых складов;
- Поставка более 17-ти миллионов наименований электронных компонентов;
- Поставка сложных, дефицитных, либо снятых с производства позиций;
- Оперативные сроки поставки под заказ (от 5 рабочих дней);
- Экспресс доставка в любую точку России;
- Техническая поддержка проекта, помощь в подборе аналогов, поставка прототипов;
- Система менеджмента качества сертифицирована по Международному стандарту ISO 9001;
- Лицензия ФСБ на осуществление работ с использованием сведений, составляющих государственную тайну;
- Поставка специализированных компонентов (Xilinx, Altera, Analog Devices, Intersil, Interpoint, Microsemi, Aeroflex, Peregrine, Syfer, Eurofarad, Texas Instrument, Miteq, Cobham, E2V, MA-COM, Hittite, Mini-Circuits, General Dynamics и др.);

Помимо этого, одним из направлений компании «ЭлектроПласт» является направление «Источники питания». Мы предлагаем Вам помощь Конструкторского отдела:

- Подбор оптимального решения, техническое обоснование при выборе компонента;
- Подбор аналогов;
- Консультации по применению компонента;
- Поставка образцов и прототипов;
- Техническая поддержка проекта;
- Защита от снятия компонента с производства.



#### Как с нами связаться

**Телефон:** 8 (812) 309 58 32 (многоканальный)

**Факс:** 8 (812) 320-02-42

**Электронная почта:** [org@eplast1.ru](mailto:org@eplast1.ru)

**Адрес:** 198099, г. Санкт-Петербург, ул. Калинина, дом 2, корпус 4, литера А.