

The SK1 is the perfect off-the-shelf linear position sensor for applications ranging from mobile construction equipment to hydraulic lift tables and anything else in between. Available in both 250 and 400-inch stroke ranges, this model offers the ultimate ease-of-use, compact design and user flexibility. Need to mount it upside down? Simply rotate its stainless mounting bracket to where you want it. Need the electrical connector to point in a different direction? Just rotate the rear cover to point the connector to the desired direction.

The SK1 is manufactured with a precision high-cycle plastic hybrid potentiometer and an extremely durable spring-loaded stainless steel measuring cable to deliver an accurate reliable voltage divider position feedback signal over the entire stroke. This model is economically priced making it the perfect solution for both the single piece user and OEM customers alike.

# SK1

## Cable Actuated Sensor

### Voltage Divider Output Signal

Linear Position to 400 inches (10 m)

Compact Design • Simple To Install

User Adjustable Measuring Cable Orientation

**IN STOCK for Quick Delivery!**

### Specifications

<b>Stroke Range Options</b>	250 inches (6.4 m), 400 inches (10.2 m)
<b>Output Signal</b>	voltage divider (potentiometric)
<b>Accuracy</b>	.35% FS.
<b>Repeatability</b>	.05% FS.
<b>Resolution</b>	essentially infinite
<b>Measuring Cable</b>	.031-inch dia. bare stainless steel
<b>Maximum Cable Velocity</b>	60 inches per second
<b>Maximum Cable Acceleration</b>	5 g
<b>Measuring Cable Tension</b>	23 oz. (6.4 N) ±40%
<b>Sensor</b>	plastic-hybrid precision potentiometer
<b>Input Resistance</b>	10K ohms, ±10%
<b>Power Rating, Watts</b>	2.0 at 70°F
<b>Recommended Maximum Input Voltage</b>	30 V (AC/DC)
<b>Output Signal Change Over Full Stroke Range</b>	94% ±4% of V(+in)
<b>Cycle Life</b>	≥ 250,000
<b>Electrical Connection</b>	4-pin M12 connector, mating plug included
<b>Enclosure</b>	glass-filled polycarbonate
<b>Environmental</b>	IP67
<b>Operating Temperature</b>	-40° to 185° F (-40° to 85° C)

### Output Signal

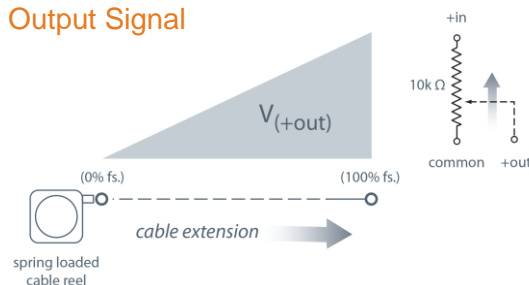

# SK1

## Voltage Divider Output Signal

### Outline Drawing

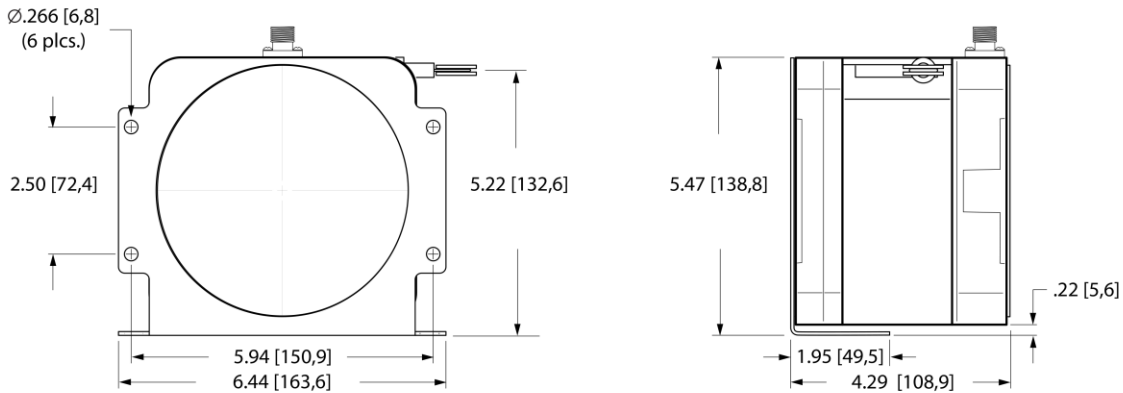
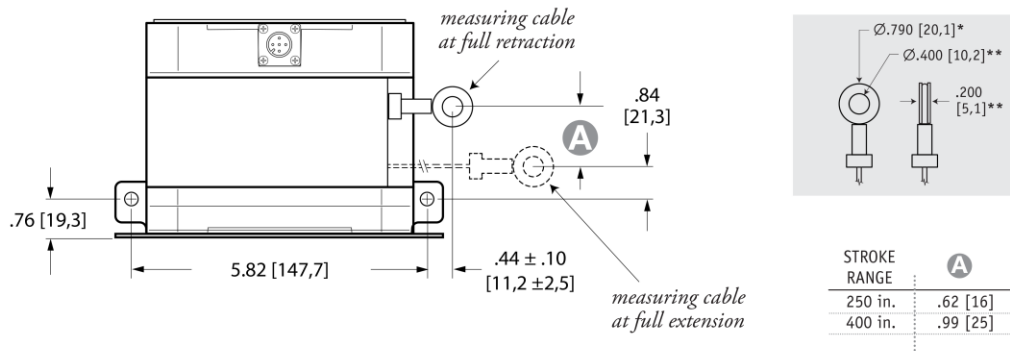

DIMENSIONS ARE IN INCHES [MM]  
tolerances are 0.04 IN. [1,0 MM] unless otherwise noted.

\* tolerance = +.005 - .001 [+0,1 -0,0]  
\*\* tolerance = +.005 - .005 [+0,1 -0,1]

### Mounting Options

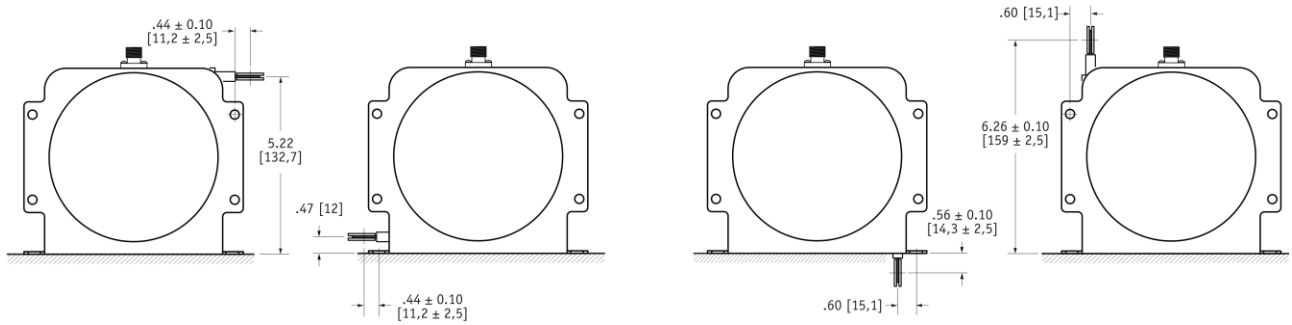

#### To change cable exit direction:

simply remove the 4 bracket mounting screws and rotate sensor body to desired direction.

#### To change electrical connector orientation:

remove the 4 rear screws and carefully remove the rear cover and rotate cover.

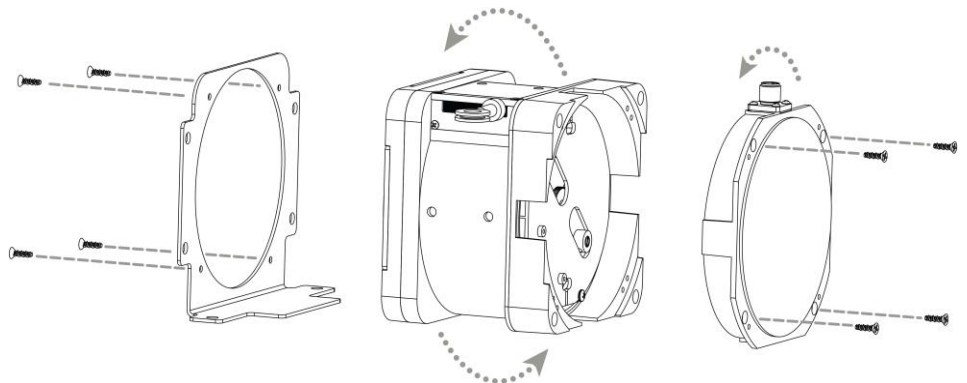

# SK1

## Voltage Divider Output Signal

### Ordering Information

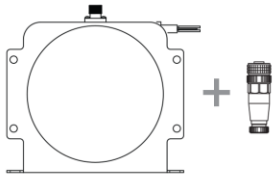

Part Number	full stroke range	accuracy	max. acceleration	measuring cable tension (± 40%)
<b>SK1-250-3</b>	250 in (6.4 m)	.35%	5 g	23 oz. (6,4 N)
<b>SK1-400-3</b>	400 in (10.2 m)	.35%	5 g	23 oz. (6,4N)

includes mounting bracket & mating connector.

### Optional Cordsets

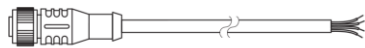

Part Number	length	wire size	connector
<b>9036810-0040</b>	13 ft (4 m)	22 AWG (.34mm <sup>2</sup> )	straight 4-pin M12



<b>9036810-0041</b>	13 ft (4 m)	22 AWG (.34mm <sup>2</sup> )	90° 4-pin M12
---------------------	-------------	------------------------------	---------------

### Electrical Connection

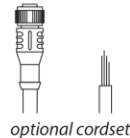
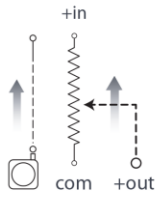

#### field installable connector

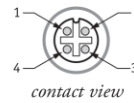

customer supplied electrical cable (.25 in [6 mm] max. dia.)

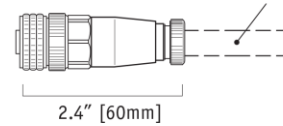

signals	pin	pin - color
<b>+in</b>	1	1 - brown
<b>common</b>	2	2 - white
<b>+out</b>	3	3 - blue
<b>n/c</b>	4	4 - black

### NORTH AMERICA

Measurement Specialties, Inc.,  
a TE Connectivity company  
20630 Plummer Street  
Chatsworth, CA 91311  
Tel +1 800 423 5483  
Tel +1 818 701 2750  
Fax +1 818 701 2799  
info@celesco.com

### TE.com/sensorsolutions

Measurement Specialties, Inc., a TE Connectivity company.

Measurement Specialties, TE Connectivity, TE Connectivity (logo) and EVERY CONNECTION COUNTS are trademarks. All other logos, products and/or company names referred to herein might be trademarks of their respective owners.

The information given herein, including drawings, illustrations and schematics which are intended for illustration purposes only, is believed to be reliable. However, TE Connectivity makes no warranties as to its accuracy or completeness and disclaims any liability in connection with its use. TE Connectivity's obligations shall only be as set forth in TE Connectivity's Standard Terms and Conditions of Sale for this product and in no case will TE Connectivity be liable for any incidental, indirect or consequential damages arising out of the sale, resale, use or misuse of the product. Users of TE Connectivity products should make their own evaluation to determine the suitability of each such product for the specific application.

© 2015 TE Connectivity Ltd. family of companies All Rights Reserved.

SK1 12/01/2015



Компания «ЭлектроПласт» предлагает заключение долгосрочных отношений при поставках импортных электронных компонентов на взаимовыгодных условиях!

Наши преимущества:

- Оперативные поставки широкого спектра электронных компонентов отечественного и импортного производства напрямую от производителей и с крупнейших мировых складов;
- Поставка более 17-ти миллионов наименований электронных компонентов;
- Поставка сложных, дефицитных, либо снятых с производства позиций;
- Оперативные сроки поставки под заказ (от 5 рабочих дней);
- Экспресс доставка в любую точку России;
- Техническая поддержка проекта, помощь в подборе аналогов, поставка прототипов;
- Система менеджмента качества сертифицирована по Международному стандарту ISO 9001;
- Лицензия ФСБ на осуществление работ с использованием сведений, составляющих государственную тайну;
- Поставка специализированных компонентов (Xilinx, Altera, Analog Devices, Intersil, Interpoint, Microsemi, Aeroflex, Peregrine, Syfer, Eurofarad, Texas Instrument, Miteq, Cobham, E2V, MA-COM, Hittite, Mini-Circuits, General Dynamics и др.);

Помимо этого, одним из направлений компании «ЭлектроПласт» является направление «Источники питания». Мы предлагаем Вам помощь Конструкторского отдела:

- Подбор оптимального решения, техническое обоснование при выборе компонента;
- Подбор аналогов;
- Консультации по применению компонента;
- Поставка образцов и прототипов;
- Техническая поддержка проекта;
- Защита от снятия компонента с производства.



#### Как с нами связаться

**Телефон:** 8 (812) 309 58 32 (многоканальный)

**Факс:** 8 (812) 320-02-42

**Электронная почта:** [org@eplast1.ru](mailto:org@eplast1.ru)

**Адрес:** 198099, г. Санкт-Петербург, ул. Калинина, дом 2, корпус 4, литера А.