T-1³/₄ (5 mm) Precision Optical Performance AllInGaP LED Lamps

Technical Data

SunPower Series

HLMP-DLXX	HLMP-GHXX
HLMP-DJXX	HLMP-GGXX
HLMP-DHXX	HLMP-ULXX
HLMP-DGXX	HLMP-UJXX
HLMP-GLXX	HLMP-UHXX
HLMP-GJXX	HLMP-UGXX

Features

- **Well Defined Spatial Radiation Patterns**
- **Viewing Angles:** 6°, 15°, 23°, 30°
- **High Luminous Output**
- **Colors:**
 - 590 nm Amber
 - 605 nm Orange
 - 615 nm Reddish-Orange
 - 626 nm Red
- **High Operating Temperature:**
 $T_{j,LED} = +130^{\circ}\text{C}$
- **Superior Resistance to Moisture**
- **Four Package Options:**
With or Without Flange Base;
With or Without Lead Stand-Offs

Benefits

- **Viewing Angles Match Traffic Management Sign Requirements**
- **Colors Meet Automotive and Pedestrian Signal Specifications**
- **Superior Performance in Outdoor Environments**
- **Suitable for Autoinsertion onto PC Boards**

Applications

- **Traffic Management:**
Traffic Signals
Pedestrian Signals
Work Zone Warning Lights
Variable Message Signs
- **Commercial Outdoor Advertising:**
Signs
Marquees
- **Automotive:**
Exterior and Interior Lights

Description

These Precision Optical Performance AllInGaP LEDs provide superior light output for excellent readability in sunlight and are extremely reliable. AllInGaP LED technology provides extremely stable light output over long periods of time. Precision Optical Performance lamps utilize the aluminum indium gallium phosphide (AllInGaP) technology.

These LED lamps are untinted, nondiffused, T-1³/₄ packages incorporating second generation optics producing well defined spatial radiation patterns at specific viewing cone angles.



These lamps are made with an advanced optical grade epoxy, offering superior high temperature and high moisture resistance performance in outdoor signal and sign applications. The high maximum LED junction temperature limit of +130°C enables high temperature operation in bright sunlight conditions. The package epoxy contains both uv-a and uv-b inhibitors to reduce the effects of long term exposure to direct sunlight.

These lamps are available in four package options to give the designer flexibility with device mounting.

Device Selection Guide

Part Number HLMP-	Typical Viewing Angle, $2\theta_{1/2}$ (Deg.) ^[4]	Color, Dominant Wavelength, λ_d (nm), ^[3] Typ.	Luminous Intensity, I_v (mcd), ^[1,2] @ 20 mA		Leads with Stand-Offs	Flanged Base	Package Drawing
			Min.	Typ.			
DL08 ^[5]	6	Amber, 590	4000	9300	No	Yes	A
GL08 ^[5]	6	Amber, 590	4000	9300	No	No	B
DL10 ^[5]	6	Amber, 590	4000	9300	Yes	Yes	C
GL10 ^[5]	6	Amber, 590	4000	9300	Yes	No	D
UL06 ^[5]	6	Amber, 590	1600	4000	No	Yes	A
UL07 ^[5]	6	Amber, 590	1600	4000	Yes	Yes	C
DJ08 ^[5]	6	Orange, 605	4200	9500	No	Yes	A
GJ08 ^[5]	6	Orange, 605	4200	9500	No	No	B
DJ10 ^[5]	6	Orange, 605	4200	9500	Yes	Yes	C
GJ10 ^[5]	6	Orange, 605	4200	9500	Yes	No	D
UJ06 ^[5]	6	Orange, 605	2000	4500	No	Yes	A
UJ07 ^[5]	6	Orange, 605	2000	4500	Yes	Yes	C
DH08 ^[5]	6	Red-Orange, 615	2900	8000	No	Yes	A
GH08 ^[5]	6	Red-Orange, 615	2900	8000	No	No	B
DH10 ^[5]	6	Red-Orange, 615	2900	8000	Yes	Yes	C
GH10 ^[5]	6	Red-Orange, 615	2900	8000	Yes	No	D
UH06 ^[5]	6	Red-Orange, 615	1400	3500	No	Yes	A
UH07 ^[5]	6	Red-Orange, 615	1400	3500	Yes	Yes	C
DG08 ^[5]	6	Red, 626	2900	6500	No	Yes	A
GG08 ^[5]	6	Red, 626	2900	6500	No	No	B
DG10 ^[5]	6	Red, 626	2900	6500	Yes	Yes	C
GG10 ^[5]	6	Red, 626	2900	6500	Yes	No	D
UG06 ^[5]	6	Red, 626	1000	3000	No	Yes	A
UG07 ^[5]	6	Red, 626	1000	3000	Yes	Yes	C
DL15	15	Amber, 590	1600	3100	No	Yes	A
GL15	15	Amber, 590	1600	3100	No	No	B
DL17	15	Amber, 590	1600	3100	Yes	Yes	C
GL17	15	Amber, 590	1600	3100	Yes	No	D
UL13	15	Amber, 590	700	1600	No	Yes	A
UL14	15	Amber, 590	700	1600	Yes	Yes	C
DJ15	15	Orange, 605	1400	3400	No	Yes	A
GJ15	15	Orange, 605	1400	3400	No	No	B
DJ17	15	Orange, 605	1400	3400	Yes	Yes	C
GJ17	15	Orange, 605	1400	3400	Yes	No	D

Notes:

1. The luminous intensity is measured on the mechanical axis of the lamp package.
2. The optical axis is closely aligned with the package mechanical axis.
3. The dominant wavelength, λ_d , is derived from the CIE Chromaticity Diagram and represents the color of the lamp.
4. $\theta_{1/2}$ is the off-axis angle where the luminous intensity is one half the on-axis intensity.
5. The intensity of narrow viewing angle lamps is measured at the intensity peak.

Device Selection Guide, continued

Part Number HLMP-	Typical Viewing Angle, $2\theta_{1/2}$ (Deg.) ^[4]	Color, Dominant Wavelength, λ_d (nm), ^[3] Typ.	Luminous Intensity, I_v (mcd), ^[1,2] @ 20 mA		Leads with Stand-Offs	Flanged Base	Package Drawing
			Min.	Typ.			
UJ13	15	Orange, 605	700	1800	No	Yes	A
UJ14	15	Orange, 605	700	1800	Yes	Yes	C
DH15	15	Red-Orange, 615	1400	2500	No	Yes	A
GH15	15	Red-Orange, 615	1400	2500	No	No	B
DH17	15	Red-Orange, 615	1400	2500	Yes	Yes	C
GH17	15	Red-Orange, 615	1400	2500	Yes	No	D
UH13	15	Red-Orange, 615	500	1400	No	Yes	A
UH14	15	Red-Orange, 615	500	1400	Yes	Yes	C
DG15	15	Red, 626	1400	2100	No	Yes	A
GG15	15	Red, 626	1400	2100	No	No	B
DG17	15	Red, 626	1400	2100	Yes	Yes	C
GG17	15	Red, 626	1400	2100	Yes	No	D
UG13	15	Red, 626	500	1000	No	Yes	A
UG14	15	Red, 626	500	1000	Yes	Yes	C
DL24	23	Amber, 590	1000	1800	No	Yes	A
GL24	23	Amber, 590	1000	1800	No	No	B
DL26	23	Amber, 590	1000	1800	Yes	Yes	C
GL26	23	Amber, 590	1000	1800	Yes	No	D
UL22	23	Amber, 590	450	1000	No	Yes	A
UL23	23	Amber, 590	450	1000	Yes	Yes	C
DJ24	23	Orange, 605	1000	2000	No	Yes	A
GJ24	23	Orange, 605	1000	2000	No	No	B
DJ26	23	Orange, 605	1000	2000	Yes	Yes	C
GJ26	23	Orange, 605	1000	2000	Yes	No	D
UJ22	23	Orange, 605	290	1200	No	Yes	A
UJ23	23	Orange, 605	290	1200	Yes	Yes	C
DH24	23	Red-Orange, 615	700	1500	No	Yes	A
GH24	23	Red-Orange, 615	700	1500	No	No	B
DH26	23	Red-Orange, 615	700	1500	Yes	Yes	C
GH26	23	Red-Orange, 615	700	1500	Yes	No	D
UH22	23	Red-Orange, 615	290	900	No	Yes	A
UH23	23	Red-Orange, 615	290	900	Yes	Yes	C

Notes:

1. The luminous intensity is measured on the mechanical axis of the lamp package.
2. The optical axis is closely aligned with the package mechanical axis.
3. The dominant wavelength, λ_d , is derived from the CIE Chromaticity Diagram and represents the color of the lamp.
4. $\theta_{1/2}$ is the off-axis angle where the luminous intensity is one half the on-axis intensity.
5. The intensity of narrow viewing angle lamps is measured at the intensity peak.

Device Selection Guide, continued

Part Number HLMP-	Typical Viewing Angle, $2\theta_{1/2}$ (Deg.) ^[4]	Color, Dominant Wavelength, λ_d (nm), ^[3] Typ.	Luminous Intensity, I_v (mcd), ^[1,2] @ 20 mA		Leads with Stand-Offs	Flanged Base	Package Drawing
			Min.	Typ.			
DG24	23	Red, 626	700	1300	No	Yes	A
GG24	23	Red, 626	700	1300	No	No	B
DG26	23	Red, 626	700	1300	Yes	Yes	C
GG26	23	Red, 626	700	1300	Yes	No	D
UG22	23	Red, 626	290	700	No	Yes	A
UG23	23	Red, 626	290	700	Yes	Yes	C
DL30	30	Amber, 590	700	1300	No	Yes	A
GL30	30	Amber, 590	700	1300	No	No	B
DL32	30	Amber, 590	700	1300	Yes	Yes	C
GL32	30	Amber, 590	700	1300	Yes	No	D
UL28	30	Amber, 590	300	750	No	Yes	A
UL29	30	Amber, 590	300	750	Yes	Yes	C
DJ30	30	Orange, 605	700	1500	No	Yes	A
GJ30	30	Orange, 605	700	1500	No	No	B
DJ32	30	Orange, 605	700	1500	Yes	Yes	C
GJ32	30	Orange, 605	700	1500	Yes	No	D
UJ28	30	Orange, 605	200	800	No	Yes	A
UJ29	30	Orange, 605	200	800	Yes	Yes	C
DH30	30	Red-Orange, 615	500	1100	No	Yes	A
GH30	30	Red-Orange, 615	500	1100	No	No	B
DH32	30	Red-Orange, 615	500	1100	Yes	Yes	C
GH32	30	Red-Orange, 615	500	1100	Yes	No	D
UH28	30	Red-Orange, 615	200	600	No	Yes	A
UH29	30	Red-Orange, 615	200	600	Yes	Yes	C
DG30	30	Red, 626	500	900	No	Yes	A
GG30	30	Red, 626	500	900	No	No	B
DG32	30	Red, 626	500	900	Yes	Yes	C
GG32	30	Red, 626	500	900	Yes	No	D
UG28	30	Red, 626	200	500	No	Yes	A
UG29	30	Red, 626	200	500	Yes	Yes	C

Notes:

1. The luminous intensity is measured on the mechanical axis of the lamp package.
2. The optical axis is closely aligned with the package mechanical axis.
3. The dominant wavelength, λ_d , is derived from the CIE Chromaticity Diagram and represents the color of the lamp.
4. $\theta_{1/2}$ is the off-axis angle where the luminous intensity is one half the on-axis intensity.
5. The intensity of narrow viewing angle lamps is measured at the intensity peak.

Package Dimensions

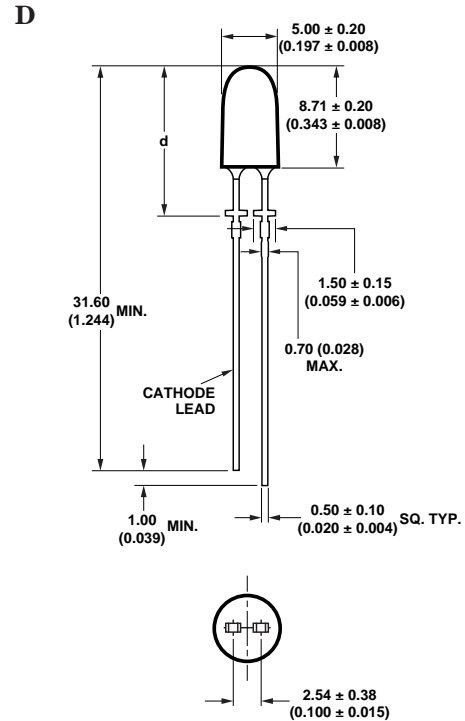
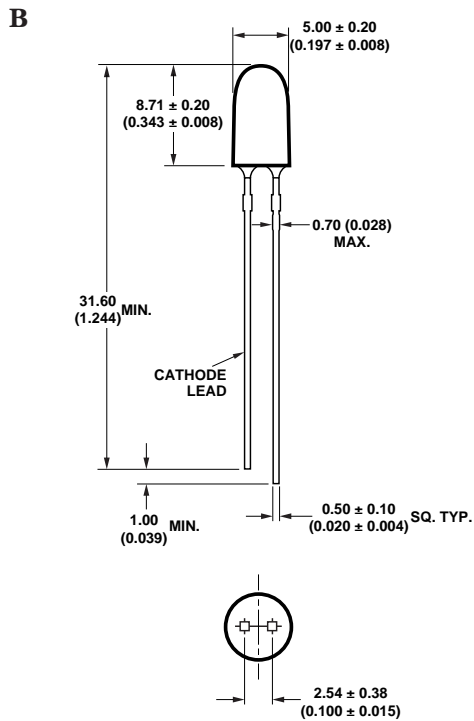
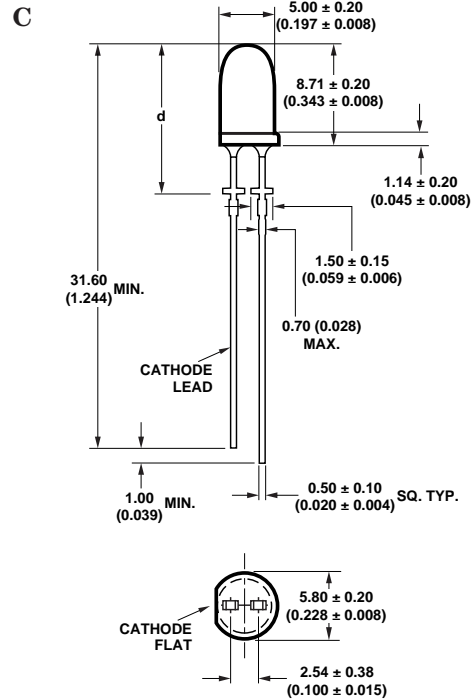
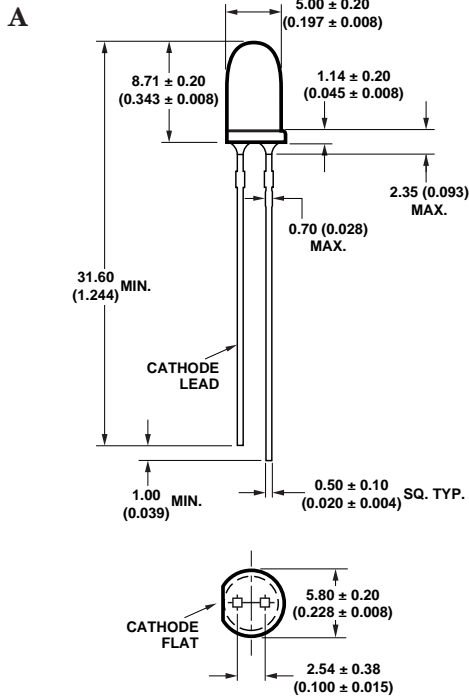

NOTES:

1. ALL DIMENSIONS ARE IN MILLIMETERS (INCHES).
2. LEADS ARE MILD STEEL, SOLDER DIPPED.
3. TAPERS SHOWN AT TOP OF LEADS (BOTTOM OF LAMP PACKAGE) INDICATE AN EPOXY MENISCUS THAT MAY EXTEND ABOUT 1 mm (0.040 in.) DOWN THE LEADS.
4. RECOMMENDED PC BOARD HOLE DIAMETERS:
 - LAMP PACKAGES A AND B WITHOUT STAND-OFFS: FLUSH MOUNTING AT BASE OF LAMP PACKAGE = 1.143/1.067 (0.044/0.042).
 - LAMP PACKAGES C AND D WITH STAND-OFFS: MOUNTING AT LEAD STAND-OFFS = 0.965/0.889 (0.038/0.035).
5. FOR DOME HEIGHTS ABOVE LEAD STAND-OFF SEATING PLANE, d, LAMP PACKAGES C AND D, SEE TABLE.

PART NO.	d
HLMP-XX10 -XX07	12.37 ± 0.25 (0.487 ± 0.010)
HLMP-XX17 -XX14	12.42 ± 0.25 (0.489 ± 0.010)
HLMP-XX26 -XX23	12.52 ± 0.25 (0.493 ± 0.010)
HLMA-XX32 -XX29	11.96 ± 0.25 (0.471 ± 0.010)

Absolute Maximum Ratings at $T_A = 25^\circ\text{C}$

DC Forward Current ^[1,2,3]	50 mA
Peak Pulsed Forward Current ^[2,3]	70 mA
Average Forward Current ^[3]	30 mA
Reverse Voltage ($I_R = 100 \mu\text{A}$)	5 V
LED Junction Temperature	130°C
Operating Temperature	-40°C to +100°C
Storage Temperature	-40°C to +120°C
Soldering Temperature	260°C for 5 seconds
[1.59 mm (0.060 in.) below seating plane]	

Notes:

1. Derate linearly as shown in Figure 4.
2. For long term performance with minimal light output degradation, drive currents between 10 mA and 30 mA are recommended.
3. Please contact your Hewlett-Packard sales representative about operating currents below 10 mA.

Electrical/Optical Characteristics at $T_A = 25^\circ\text{C}$

Parameter	Symbol	Min.	Typ.	Max.	Units	Test Conditions
Forward Voltage Amber ($\lambda_d = 590 \text{ nm}$) Orange ($\lambda_d = 605 \text{ nm}$) Red-Orange ($\lambda_d = 615 \text{ nm}$) Red ($\lambda_d = 626 \text{ nm}$)	V_F		2.02 1.98 1.94 1.90	2.4	V	$I_F = 20 \text{ mA}$
Reverse Voltage	V_R	5	20		V	$I_F = 100 \mu\text{A}$
Peak Wavelength: Amber ($\lambda_d = 590 \text{ nm}$) Orange ($\lambda_d = 605 \text{ nm}$) Red-Orange ($\lambda_d = 615 \text{ nm}$) Red ($\lambda_d = 626 \text{ nm}$)	λ_{PEAK}		592 609 621 635		nm	Peak of Wavelength of Spectral Distribution at $I_F = 20 \text{ mA}$
Spectral Halfwidth	$\Delta\lambda_{1/2}$		17		nm	Wavelength Width at Spectral Distribution $1/2$ Power Point at $I_F = 20 \text{ mA}$
Speed of Response	τ_s		20		ns	Exponential Time Constant, e^{-t/τ_s}
Capacitance	C		40		pF	$V_F = 0, f = 1 \text{ MHz}$
Thermal Resistance	$R\theta_{\text{J-PIN}}$		240		$^\circ\text{C/W}$	LED Junction-to-Cathode Lead
Luminous Efficacy ^[1] Amber ($\lambda_d = 590 \text{ nm}$) Orange ($\lambda_d = 605 \text{ nm}$) Red-Orange ($\lambda_d = 615 \text{ nm}$) Red ($\lambda_d = 626 \text{ nm}$)	η_v		480 370 260 150		lm/W	Emitted Luminous Power/Emitted Radiant Power

Note:

1. The radiant intensity, I_e , in watts per steradian, may be found from the equation $I_e = I_v/\eta_v$, where I_v is the luminous intensity in candelas and η_v is the luminous efficacy in lumens/watt.

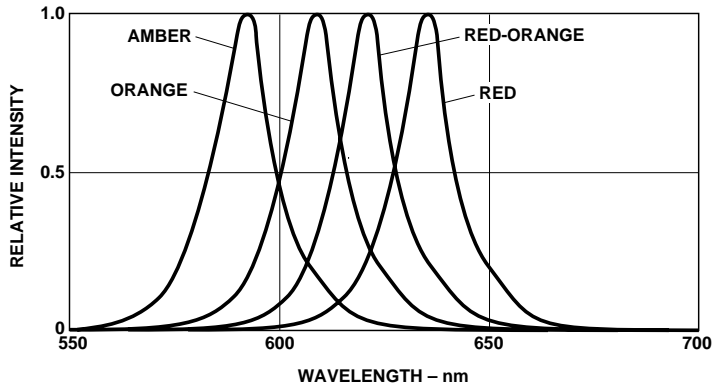

Figure 1. Relative Intensity vs. Peak Wavelength.

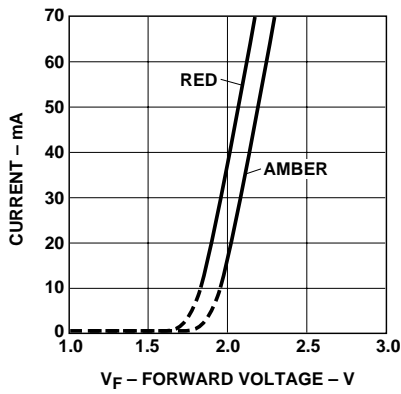

Figure 2. Forward Current vs. Forward Voltage.

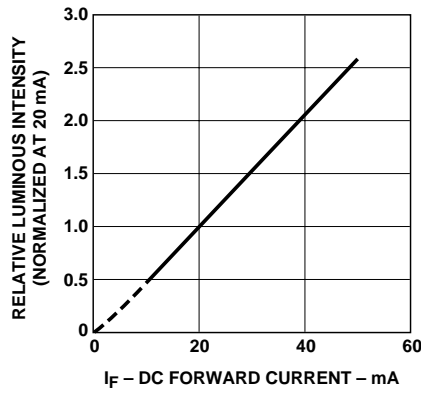

Figure 3. Relative Luminous Intensity vs. Forward Current.

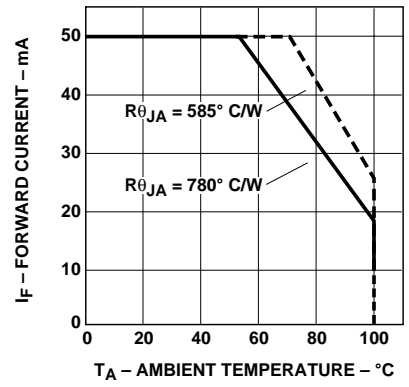

Figure 4. Maximum Forward Current vs. Ambient Temperature. Derating Based on $T_{JMAX} = 130^\circ \text{C}$.

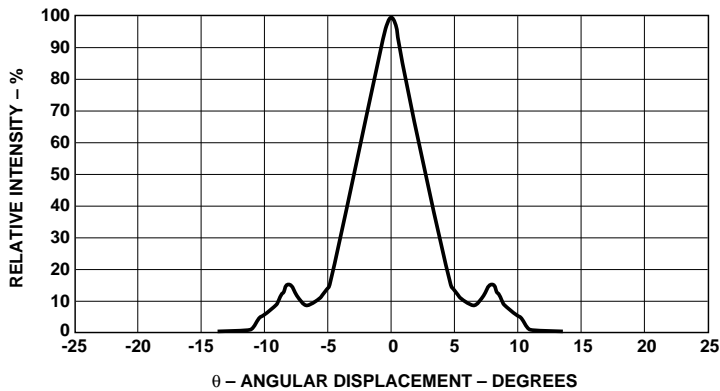

Figure 5. Representative Spatial Radiation Pattern for 6° Viewing Angle Lamps.

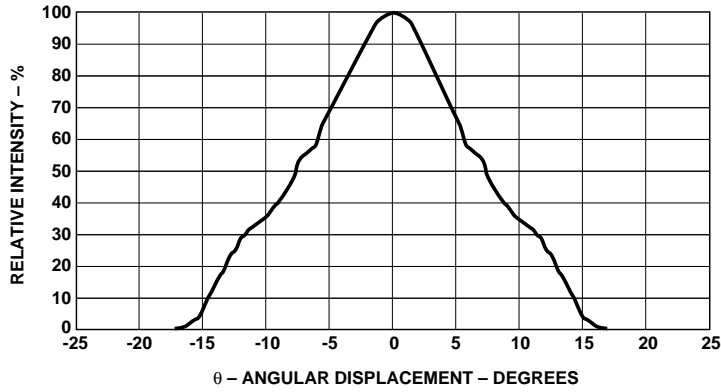

Figure 6. Representative Spatial Radiation Pattern for 15° Viewing Angle Lamps.

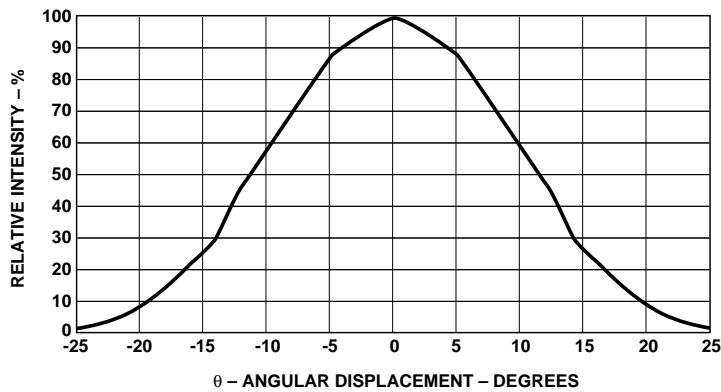

Figure 7. Representative Spatial Radiation Pattern for 23° Viewing Angle Lamps.

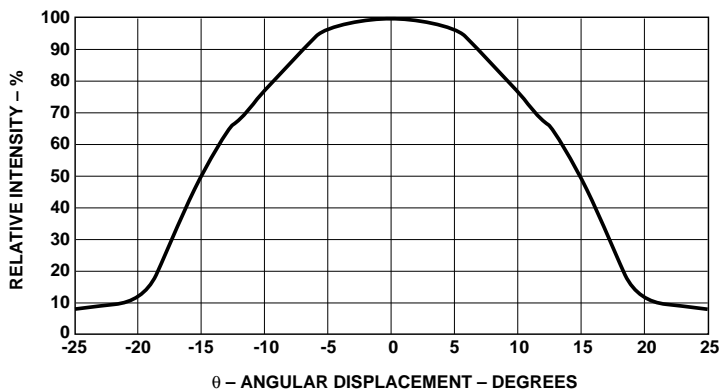

Figure 8. Representative Spatial Radiation Pattern for 30° Viewing Angle Lamps.

For technical assistance or the location of your nearest Hewlett-Packard sales office, distributor or representative call:

Americas/Canada: 1-800-235-0312 or 408-654-8675

Far East/Australasia: (65) 290-6305

Japan: (81 3) 3335-8152

Europe: Call your local HP sales office.

Data subject to change.

Copyright © 1997 Hewlett-Packard Co.

Obsoletes 5965-5265E

Printed in U.S.A. 5965-6807E (1/97)



Компания «ЭлектроПласт» предлагает заключение долгосрочных отношений при поставках импортных электронных компонентов на взаимовыгодных условиях!

Наши преимущества:

- Оперативные поставки широкого спектра электронных компонентов отечественного и импортного производства напрямую от производителей и с крупнейших мировых складов;
- Поставка более 17-ти миллионов наименований электронных компонентов;
- Поставка сложных, дефицитных, либо снятых с производства позиций;
- Оперативные сроки поставки под заказ (от 5 рабочих дней);
- Экспресс доставка в любую точку России;
- Техническая поддержка проекта, помощь в подборе аналогов, поставка прототипов;
- Система менеджмента качества сертифицирована по Международному стандарту ISO 9001;
- Лицензия ФСБ на осуществление работ с использованием сведений, составляющих государственную тайну;
- Поставка специализированных компонентов (Xilinx, Altera, Analog Devices, Intersil, Interpoint, Microsemi, Aeroflex, Peregrine, Syfer, Eurofarad, Texas Instrument, Miteq, Cobham, E2V, MA-COM, Hittite, Mini-Circuits, General Dynamics и др.);

Помимо этого, одним из направлений компании «ЭлектроПласт» является направление «Источники питания». Мы предлагаем Вам помощь Конструкторского отдела:

- Подбор оптимального решения, техническое обоснование при выборе компонента;
- Подбор аналогов;
- Консультации по применению компонента;
- Поставка образцов и прототипов;
- Техническая поддержка проекта;
- Защита от снятия компонента с производства.



Как с нами связаться

Телефон: 8 (812) 309 58 32 (многоканальный)

Факс: 8 (812) 320-02-42

Электронная почта: org@eplast1.ru

Адрес: 198099, г. Санкт-Петербург, ул. Калинина, дом 2, корпус 4, литера А.