

NBA3N206S

3.3 V Automotive Grade M-LVDS Driver Receiver

Description

The NBA3N206S is a 3.3 V supply differential Multipoint Low Voltage (M-LVDS) line Driver and Receiver for automotive applications. NBA3N206S offers the Type 2 receiver threshold at 0.1 V.

The NBA3N206S has Type-2 receivers that detect the bus state with as little as 50 mV of differential input voltage over a common-mode voltage range of -1 V to 3.4 V. Type-2 receivers include an offset threshold to provide a detectable voltage under open-circuit, idle-bus, and other faults conditions.

NBA3N206S supports Simplex or Half Duplex bus configurations.

Features

- Low-Voltage Differential 30 Ω to 55 Ω Line Drivers and Receivers for Signaling Rates Up to 200 Mbps
- Type-2 Receivers Provide an Offset (100 mV) Threshold to Detect Open-Circuit and Idle-Bus Conditions
- Controlled Driver Output Voltage Transition Times for Improved Signal Quality
- -1 V to 3.4 V Common-Mode Voltage Range Allows Data Transfer With up to 2 V of Ground Noise
- Bus Pins High Impedance When Disabled or $V_{CC} \leq 1.5$ V
- M-LVDS Bus Power Up/Down Glitch Free
- Operating range: $V_{CC} = 3.3 \pm 10\%$ V(3.0 to 3.6 V)
- Operation from -40°C to +125°C.
- AEC-Q100 Qualified and PPAP Capable
- These are Pb-Free Devices

Applications

- Low-Power High-Speed Short-Reach Alternative to TIA/EIA-485
- Backplane or Cabled Multipoint Data and Clock Transmission
- Cellular Base Stations
- Central-Office Switches
- Network Switches and Routers
- Automotive



ON Semiconductor®

www.onsemi.com

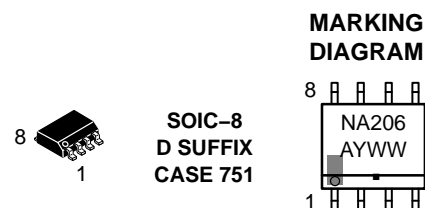

NA206 = Specific Device Code
A = Assembly Location
Y = Year
WW = Work Week
G or ■ = Pb-Free Package

ORDERING INFORMATION

See detailed ordering and shipping information in the package dimensions section on page 17 of this data sheet.

NBA3N206S

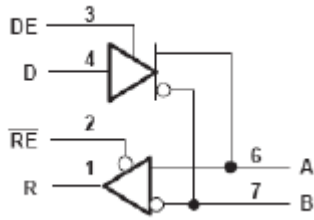

Figure 1. Logic Diagram

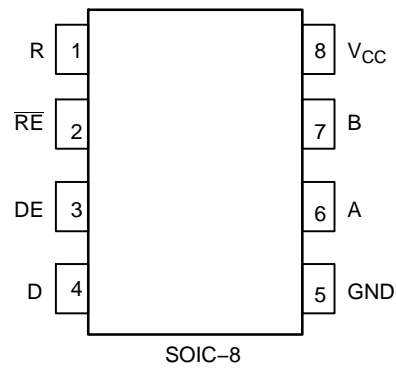

Figure 2. Pinout Diagram
(Top View)

Table 1. PIN DESCRIPTION

| Number | Name | I/O Type | Open Default | Description |
|--------|------|----------------------|--------------|---|
| 1 | R | LVC MOS Output | | Receiver Output Pin |
| 2 | RE | LVC MOS Input | High | Receiver Enable Input Pin (LOW = Active, HIGH = High Z Output) |
| 3 | DE | LVC MOS Input | Low | Driver Enable Input Pin (LOW = High Z Output, HIGH=Active) |
| 4 | D | LVC MOS Input | | Driver Input Pin |
| 5 | GND | | | Ground Supply pin. Pin must be connected to power supply to guarantee proper operation. |
| 6 | A | M-LVDS Input /Output | | Transceiver True Input /Output Pin |
| 7 | B | M-LVDS Input /Output | | Transceiver Invert Input /Output Pin |
| 8 | VCC | | | Power Supply pin. Pin must be connected to power supply to guarantee proper operation. |

Table 2. DEVICE FUNCTION TABLE

| | Inputs | | Output | |
|-----------------|---|-------|--------|--------|
| | $V_{ID} = V_A - V_B$ | RE | R | |
| TYPE 2 Receiver | $V_{ID} \geq 150 \text{ mV}$ | L | H | |
| | $50 \text{ mV} < V_{ID} < 150 \text{ mV}$ | L | ? | |
| | $V_{ID} \leq 50 \text{ mV}$ | L | L | |
| | X | H | Z | |
| | X | Open | Z | |
| | Open | L | L | |
| | DRIVER | Input | Enable | Output |
| D | | DE | A / Y | B / Z |
| L | | H | L | H |
| H | | H | H | L |
| Open | | H | L | H |
| X | | Open | Z | Z |
| X | | L | Z | Z |

H = High, L = Low, Z = High Impedance, X = Don't Care, ? = Indeterminate

NBA3N206S

Table 3. ATTRIBUTES (Note 1)

| Characteristics | | | Value |
|---|--|------------------|-----------------------------------|
| ESD Protection | Human Body Model (JEDEC Standard 22, Method A114-A) | A, B All Pins | ±6 kV ±2 kV |
| | Machine Model | All Pins | ±200 V |
| | Charged –Device Model (JEDEC Standard 22, Method C101) | All Pins | ±1500 V |
| Moisture Sensitivity, Indefinite Time Out of Drypack (Note 1) | | | Level 1 |
| Flammability Rating Oxygen Index | | | UL-94 code V-0 A 1/8" 28 to 34 |
| Transistor Count | | | 917 Devices |
| Meets or exceeds JEDEC Spec EIA/JESD78 IC Latchup Test | | | |

1. For additional information, see Application Note AND8003/D.

Table 4. MAXIMUM RATINGS

| Symbol | Parameter | Condition 1 | Condition 2 | Rating | Unit |
|------------------|--|--------------------|--|--|-------------------|
| V _{CC} | Supply Voltage | | | -0.5 ≤ V _{CC} ≤ 4.0 | V |
| V _{IN} | Input Voltage | D, DE, RE | | -0.5 ≤ V _{IN} ≤ 4.0 | V |
| | | A, B | | -1.8 ≤ V _{IN} ≤ 4.0 | |
| I _{OUT} | Output Voltage | R A, B | | -0.3 ≤ I _{OUT} ≤ 4.0 -1.8 ≤ I _{OUT} ≤ 4.0 | V |
| T _A | Operating Temperature Range, Industrial | | | -40 to ≤ +125 | °C |
| T _{stg} | Storage Temperature Range | | | -65 to +150 | °C |
| θ _{JA} | Thermal Resistance (Junction-to-Ambient) | 0 lfpm 500 lfpm | SOIC-8 | 190 130 | °C/W °C/W |
| θ _{JC} | Thermal Resistance (Junction-to-Case) | (Note 2) | SOIC-8 | 41 to 44 | °C/W |
| T _{sol} | Wave Solder | | | 265 | °C |
| P _D | Power Dissipation (Continuous) | | T _A = 25°C 25°C < T _A < 125°C T _A = 125°C | 725 5.8 377 | mW mW/°C mW |

Stresses exceeding those listed in the Maximum Ratings table may damage the device. If any of these limits are exceeded, device functionality should not be assumed, damage may occur and reliability may be affected.

2. JEDEC standard multilayer board – 2S2P (2 signal, 2 power).

NBA3N206S

Table 5. DC CHARACTERISTICS $V_{CC} = 3.3 \pm 10\% V$ (3.0 to 3.6 V), $GND = 0 V$, $T_A = -40^\circ C$ to $+125^\circ C$ (See Notes 4, 5)

| Symbol | Characteristic | Min | Typ | Max | Unit |
|----------|---|------|---------------|---------------------|------|
| ICC | Power Supply Current Receiver Disabled Driver Enabled \overline{RE} and DE at V_{CC} , $R_L = 50 \Omega$, All others open Driver and Receiver Disabled RE at V_{CC} , DE at 0 V, $R_L = \text{No Load}$, All others open Driver and Receiver Enabled RE at 0 V, DE at V_{CC} , $R_L = 50 \Omega$, All others open Receiver Enabled Driver Disabled RE at 0 V, DE at 0 V, $R_L = 50 \Omega$, All others open | | 13 1 16 | 22 4 24 13 | mA |
| V_{IH} | Input HIGH Voltage | 2 | | V_{CC} | V |
| V_{IL} | Input LOW Voltage | GND | | 0.8 | V |
| VBUS | Voltage at any bus terminal VA, VB, VY or VZ | -1.4 | | 3.8 | V |
| VID | Magnitude of differential input voltage | 0.05 | | V_{CC} | |

DRIVER

| | | | | | |
|---------------------|---|---------------|--|--------------|---------|
| $ V_{AB} $ | Differential output voltage magnitude (see Figure 4) | 440 | | 690 | mV |
| $\Delta V_{AB} $ | Change in Differential output voltage magnitude between logic states (see Figure 4) | -50 | | 50 | mV |
| $V_{OS(SS)}$ | Steady state common mode output voltage (see Figure 5) | 0.8 | | 1.2 | V |
| $\Delta V_{OS(SS)}$ | Change in Steady state common mode output voltage between logic states (see Figure 5) | -50 | | 50 | mV |
| $V_{OS(PP)}$ | Peak-to-peak common-mode output voltage (see Figure 5) | | | 150 | mV |
| V_{AOC} | Maximum steady-state open-circuit output voltage (see Figure 9) | 0 | | 2.4 | V |
| V_{BOC} | Maximum steady-state open-circuit output voltage (see Figure 9) | 0 | | 2.4 | V |
| $V_{P(H)}$ | Voltage overshoot, low-to-high level output (see Figure 7) | | | $1.2 V_{SS}$ | V |
| $V_{P(L)}$ | Voltage overshoot, high-to-low level output (see Figure 7) | $-0.2 V_{SS}$ | | | V |
| I_{IH} | High-level input current (D, DE) $V_{IH} = 2 V$ | 0 | | 10 | μA |
| I_{IL} | Low-level input current (D, DE) $V_{IL} = 0.8 V$ | 0 | | 10 | μA |
| I_{OSJ} | Differential short-circuit output current magnitude (see Figure 6) | | | 24 | mA |
| I_{OZ} | High-impedance state output current (driver only) $-1.4 V \leq (VA \text{ or } VB) \leq 3.8 V$, other output at 1.2 V | -15 | | 10 | μA |
| $I_{O(OFF)}$ | Power-off output current ($0 V \leq V_{CC} \leq 1.5 V$) $-1.4 V \leq (VA \text{ or } VB) \leq 3.8 V$, other output at 1.2 V | -10 | | 10 | μA |

RECEIVER

| | | | | | |
|-------------|--|-----|---|-----|---------|
| V_{IT+} | Positive-going Differential Input voltage Threshold (See Figure 11 & Table 8) Type 2 | | | 150 | mV |
| V_{IT-} | Negative-going Differential Input voltage Threshold (See Figure 11 & Table 8) Type 2 | 50 | | | mV |
| V_{HYS} | Differential Input Voltage Hysteresis (See Figure 11 and Table 2) Type 2 | | 0 | | mV |
| VOH | High-level output voltage ($I_{OH} = -8 \text{ mA}$) | 2.4 | | | V |
| VOL | Low-level output voltage ($I_{OL} = 8 \text{ mA}$) | | | 0.4 | V |
| I_{IH} | \overline{RE} High-level input current ($V_{IH} = 2 V$) | -10 | | 0 | μA |
| I_{IL} | \overline{RE} Low-level input current ($V_{IL} = 0.8 V$) | -10 | | 0 | μA |
| I_{OZ} | High-impedance state output current ($V_O = 0 V$ of 3.6 V) | -10 | | 15 | μA |
| C_A / C_B | Input Capacitance $V_I = 0.4 \sin(30E^6\pi t) + 0.5 V$, other outputs at 1.2 V using HP4194A impedance analyzer (or equivalent) | | 3 | | pF |
| C_{AB} | Differential Input Capacitance $V_{AB} = 0.4 \sin(30E^6\pi t) V$, other outputs at 1.2 V using HP4194A impedance analyzer (or equivalent) | | | 2.5 | pF |
| $C_{A/B}$ | Input Capacitance Balance, (C_A/C_B) | 99 | | 101 | % |

NBA3N206S

Table 5. DC CHARACTERISTICS VCC = 3.3 ±10% V(3.0 to 3.6 V), GND = 0 V, TA = -40°C to +125°C (See Notes 4, 5)

| Symbol | Characteristic | Min | Typ (Note 4) | Max | Unit |
|-----------------------------|---|-----------------|--------------|---------------|------|
| BUS INPUT AND OUTPUT | | | | | |
| IA | Input Current Receiver or Transceiver with Driver Disabled VA = 3.8 V, VB = 1.2 V VA = 0.0 V or 2.4 V, VB = 1.2 V VA = -1.4 V, VB = 1.2 V | 0 -20 -32 | | 32 20 0 | uA |
| IB | Input Current Receiver or Transceiver with Driver Disabled VB = 3.8 V, VA = 1.2 V VB = 0.0 V or 2.4 V, VA = 1.2 V VB = -1.4 V, VA = 1.2 V | 0 -20 -32 | | 32 20 0 | uA |
| IAB | Differential Input Current Receiver or Transceiver with driver disabled (IA-IB) VA = VB, -1.4 ≤ VA ≤ 3.8 V | -4 | | 4 | uA |
| IA(OFF) | Input Current Receiver or Transceiver Power Off 0V ≤ VCC ≤ 1.5 and: VA = 3.8 V, VB = 1.2 V VA = 0.0 V or 2.4 V, VB = 1.2 V VA = -1.4 V, VB = 1.2 V | 0 -20 -32 | | 32 20 0 | uA |
| IB(OFF) | Input Current Receiver or Transceiver Power Off 0V ≤ VCC ≤ 1.5 and: VB = 3.8 V, VA = 1.2 V VB = 0.0 V or 2.4 V, VA = 1.2 V VB = -1.4 V, VA = 1.2 V | 0 -20 -32 | | 32 20 0 | uA |
| IAB(OFF) | Receiver Input or Transceiver Input/Output Power Off Differential Input Current; (IA-IB) VA = VB, 0 ≤ VCC ≤ 1.5 V, -1.4 ≤ VA ≤ 3.8 V | -4 | | 4 | uA |
| CA | Transceiver Input Capacitance with Driver Disabled VA = 0.4 sin(30E6πt) + 0.5 V using HP4194A impedance analyzer (or equivalent); VB = 1.2 V | | 5 | | pF |
| CB | Transceiver Input Capacitance with Driver Disabled VB = 0.4 sin(30E6πt) + 0.5 V using HP4194A impedance analyzer (or equivalent); VA = 1.2 V | | 5 | | pF |
| CAB | Transceiver Differential Input Capacitance with Driver Disabled VA = 0.4 sin(30E6πt) + 0.5 V using HP4194A impedance analyzer (or equivalent); VB = 1.2 V | | | 3.0 | pF |
| CA/B | Transceiver Input Capacitance Balance with Driver Disabled, (CA/CB) | 99 | | 101 | % |

NOTE: Device will meet the specifications after thermal equilibrium has been established when mounted in a test socket or printed circuit board with maintained transverse airflow greater than 500 lpm.

3. See Figure 3. DC Measurements reference.
4. Typ value at 25°C and 3.3 VCC supply voltage.

Table 6. DRIVER AC CHARACTERISTICS VCC = 3.3 ±10% V(3.0 to 3.6 V), GND = 0 V, TA = -40°C to +125°C (Note 5)

| Symbol | Characteristic | Min | Typ | Max | Unit |
|-------------|--|-----|-----|-----|------|
| tPLH / tPHL | Propagation Delay (See Figure 7) | 1.0 | 1.5 | 2.4 | ns |
| tPHZ / tPLZ | Disable Time HIGH or LOW state to High Impedance (See Figure 8) | | | 7 | ns |
| tPZH / tPZL | Enable Time High Impedance to HIGH or LOW state (See Figure 8) | | | 7 | ns |
| tSK(P) | Pulse Skew (tPLH - tPHL) (See Figure 7) | | 0 | 150 | ps |
| tSK(PP) | Device to Device Skew similar path and conditions (See Figure 7) | | | 1 | ns |
| tJIT(PER) | Period Jitter RMS, 100 MHz (Source tr/ft 0.5 ns, 10 and 90 % points, 30k samples. Source jitter de-embedded from Output values) (See Figure 10) | | 2 | 3.5 | ps |
| tJIT(PP) | Peak-to-peak Jitter, 200 Mbps 2 ¹⁵ -1 PRBS (Source tr/ft 0.5 ns, 10 and 90% points, 100k samples. Source jitter de-embedded from Output values) (See Figure 10) | | 30 | 150 | ps |
| tr / tf | Differential Output rise and fall times (See Figure 7) | 0.9 | | 1.6 | ns |

NOTE: Device will meet the specifications after thermal equilibrium has been established when mounted in a test socket or printed circuit board with maintained transverse airflow greater than 500 lpm.

5. Typ value at 25°C and 3.3 VCC supply voltage.

NBA3N206S

Table 7. RECEIVER AC CHARACTERISTICS VCC = 3.3 ±10% V (3.0 to 3.6 V), GND = 0 V, TA = -40°C to +125°C (Note 6)

| Symbol | Characteristic | Min | Typ | Max | Unit |
|-------------------------------------|--|-----|-----|-----|------|
| t _{PLH} / t _{PHL} | Propagation Delay (See Figure 12) | 2 | 4 | 6 | ns |
| t _{PHZ} / t _{PLZ} | Disable Time HIGH or LOW state to High Impedance (See Figure 13) | | | 10 | ns |
| t _{PZH} / t _{PZL} | Enable Time High Impedance to HIGH or LOW state (See Figure 13) | | | 18 | ns |
| t _{SK(P)} | Pulse Skew (t _{PLH} - t _{PHL}) (See Figure 14) C _L = 5 pF Type 2 | | 300 | 500 | ps |
| t _{SK(PP)} | Device to Device Skew similar path and conditions (See Figure 12) C _L = 5 pF | | | 1 | ns |
| t _{JIT(PER)} | Period Jitter RMS, 100 MHz (Source: VID = 200 mV _{pp} , VID = 400 mV _{pp} , V _{CM} = 1 V, tr/tf 0.5 ns, 10 and 90 % points, 30k samples. Source jitter de-embedded from Output values) (See Figure 14) | | 4 | 8 | ps |
| t _{JIT(PP)} | Peak-to-peak Jitter, 200 Mbps 2 ¹⁵ -1 PRBS (Source tr/tf 0.5 ns, 10% and 90% points, 100k samples. Source jitter de-embedded from Output values) (See Figure 14) Type 2 | | 450 | 900 | ps |
| tr / tf | Differential Output rise and fall times (See Figure 14) C _L = 15 pF | 1 | | 2.3 | ns |

6. Typ value at 25°C and 3.3 VCC supply voltage. .

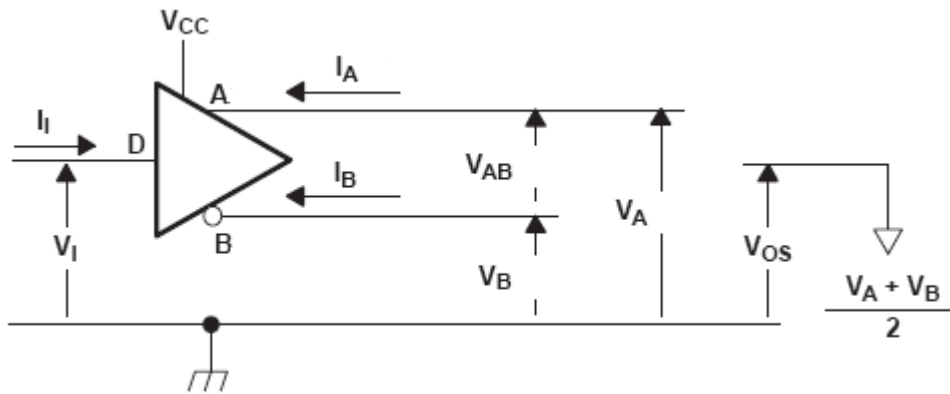
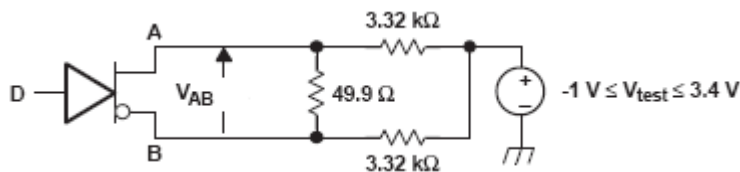

Figure 3. Driver Voltage and Current Definitions



A. All resistors are 1% tolerance.

Figure 4. Differential Output Voltage Test Circuit

NBA3N206S

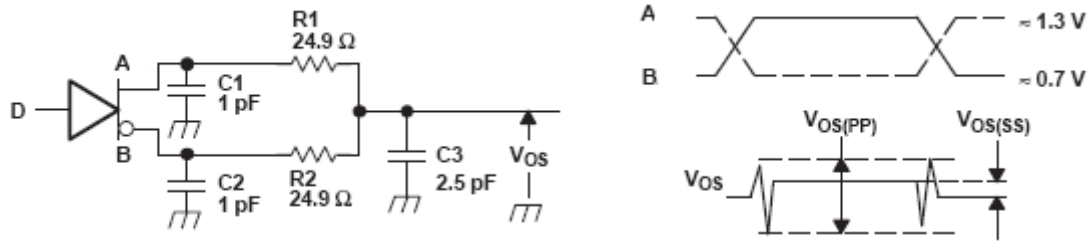

- A. All input pulses are supplied by a generator having the following characteristics: t_r or $t_f \leq 1$ ns, pulse frequency = 500 kHz, duty cycle = $50 \pm 5\%$.
- B. C1, C2 and C3 include instrumentation and fixture capacitance within 2 cm of the D.U.T. and are 20% tolerance.
- C. R1 and R2 are metal film, surface mount, 1% tolerance, and located within 2 cm of the D.U.T.
- D. The measurement of $V_{OS(PP)}$ is made on test equipment with a -3 dB bandwidth of at least 1 GHz.

Figure 5. Test Circuit and Definitions for the Driver Common-Mode Output Voltage

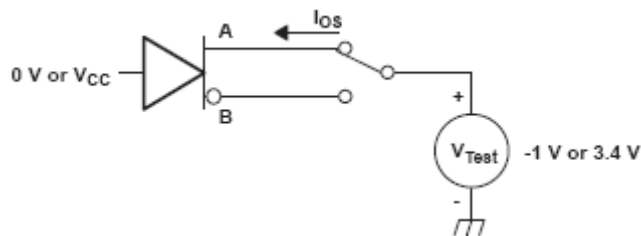
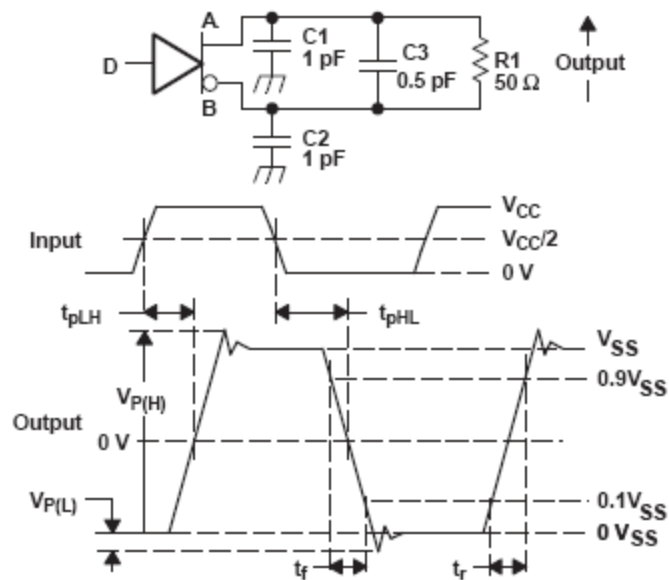

Figure 6. Driver Short-Circuit Test Circuit



- A. All input pulses are supplied by a generator having the following characteristics: t_r or $t_f \leq 1$ ns, frequency = 500 kHz, duty cycle = $50 \pm 5\%$.
- B. C1, C2, and C3 include instrumentation and fixture capacitance within 2 cm of the D.U.T. and are 20%.
- C. R1 is a metal film, surface mount, and 1% tolerance and located within 2 cm of the D.U.T.
- D. The measurement is made on test equipment with a -3 dB bandwidth of at least 1 GHz.

Figure 7. Driver Test Circuit, Timing, and Voltage Definitions for the Differential Output Signal

NBA3N206S

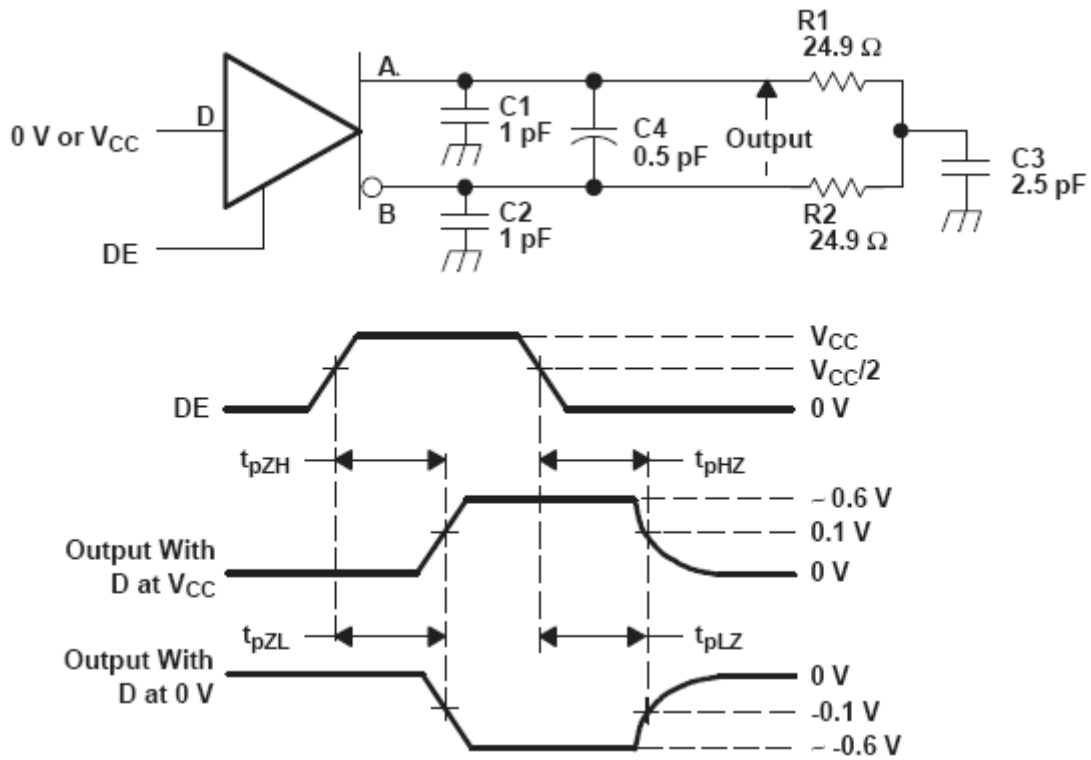

- A. All input pulses are supplied by a generator having the following characteristics: t_r or $t_f \leq 1$ ns, frequency = 500 kHz, duty cycle = $50 \pm 5\%$.
- B. C1, C2, C3, and C4 includes instrumentation and fixture capacitance within 2 cm of the D.U.T. and are 20%.
- C. R1 and R2 are metal film, surface mount, and 1% tolerance and located within 2 cm of the D.U.T.
- D. The measurement is made on test equipment with a -3 dB bandwidth of at least 1 GHz.

Figure 8. Driver Enable and Disable Time Circuit and Definitions

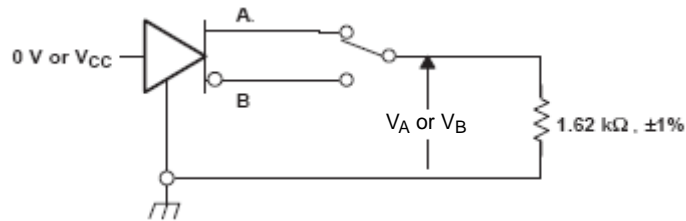
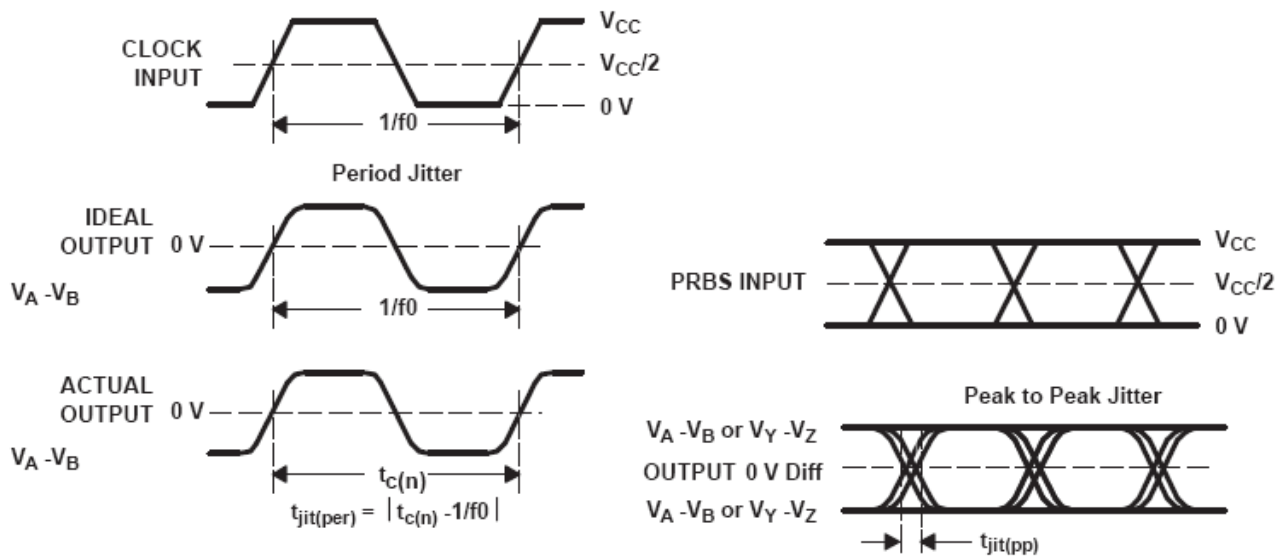

Figure 9. Maximum Steady State Output Voltage



- A. All input pulses are supplied by an Agilent 8304A Stimulus System.
- B. The measurement is made on a TEK TDS6604 running TDSJIT3 application software
- C. Period jitter is measured using a 100 MHz 50 ±1% duty cycle clock input.
- D. Peak-to-peak jitter is measured using a 200 Mbps 215-1 PRBS input.

Figure 10. Driver Jitter Measurement Waveforms

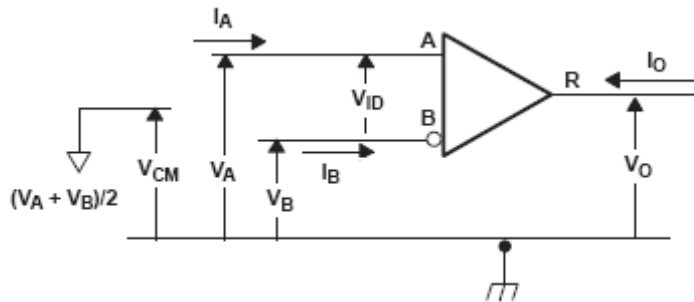
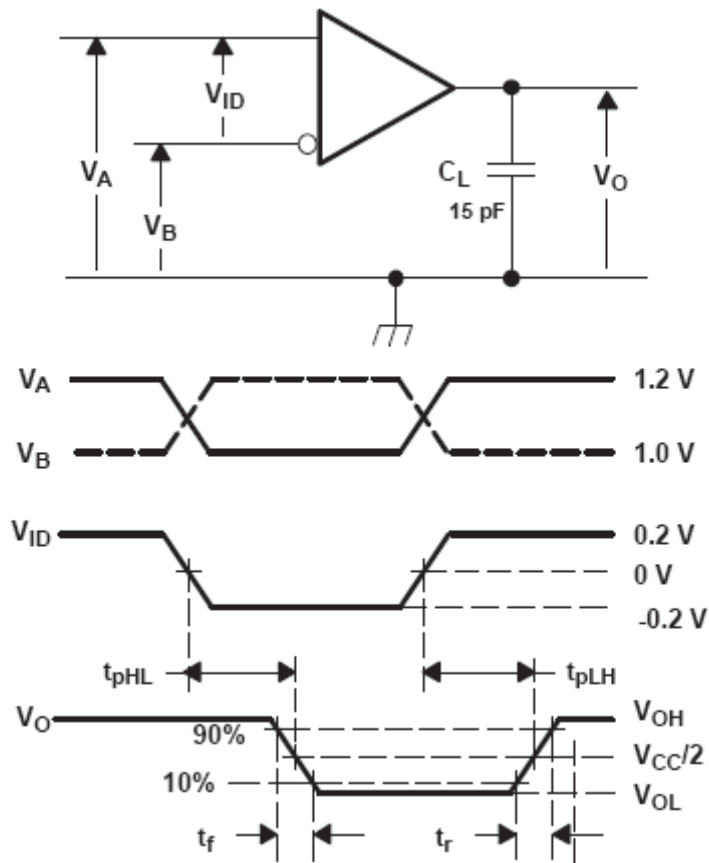

Figure 11. Receiver Voltage and Current Definitions

NBA3N206S



- A. All input pulses are supplied by a generator having the following characteristics: t_r or $t_f \leq 1 \text{ ns}$, frequency = 50 MHz, duty cycle = 50 $\pm 5\%$. C_L is a combination of a 20%–tolerance, low–loss ceramic, surface–mount capacitor and fixture capacitance within 2 cm of the D.U.T.
- B. The measurement is made on test equipment with a -3 dB bandwidth of at least 1 GHz.

Figure 12. Receiver Timing Test Circuit and Waveforms

NBA3N206S

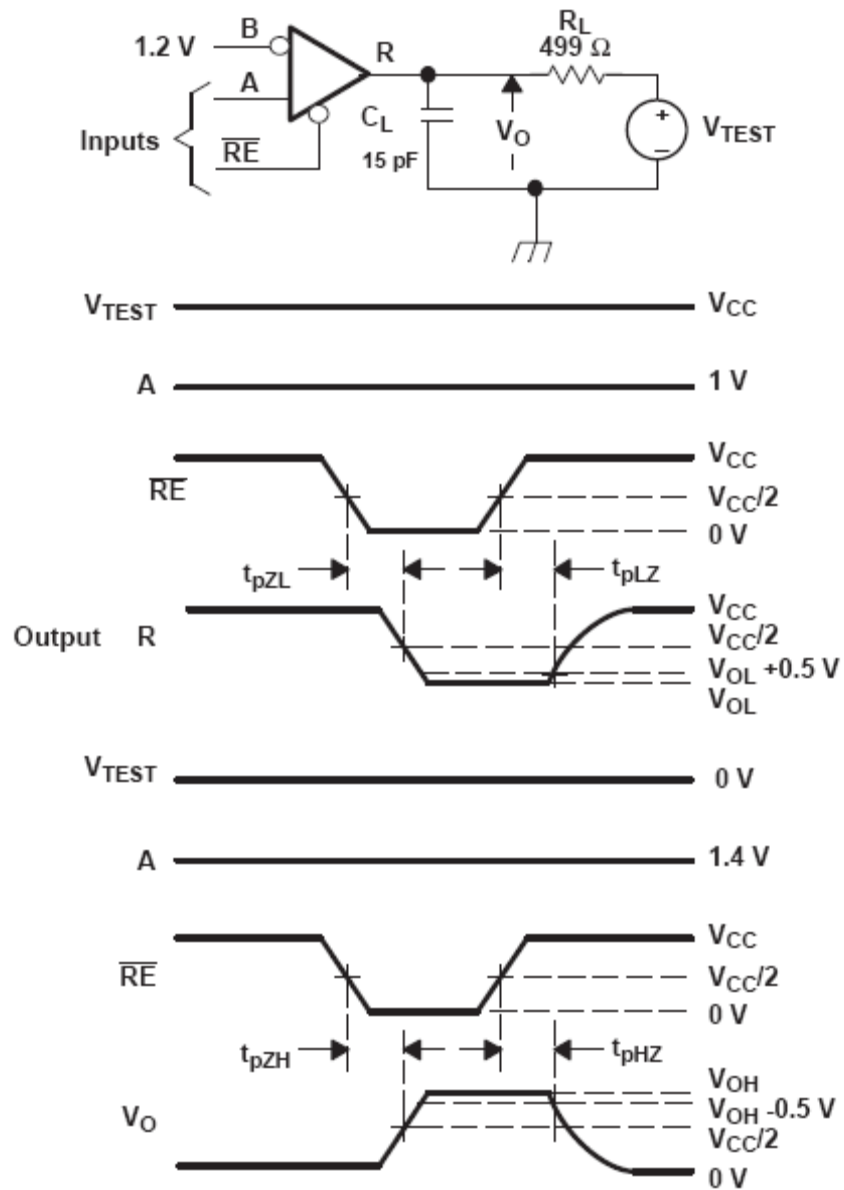

A. All input pulses are supplied by a generator having the following characteristics: t_r or $t_f \leq 1$ ns, frequency = 500 kHz, duty cycle = 50 \pm 5%.

B. R_L is 1% tolerance, metal film, surface mount, and located within 2 cm of the D.U.T.

C. C_L is the instrumentation and fixture capacitance within 2 cm of the DUT and 20%.

Figure 13. Receiver Enable/Disable Time Test Circuit and Waveforms

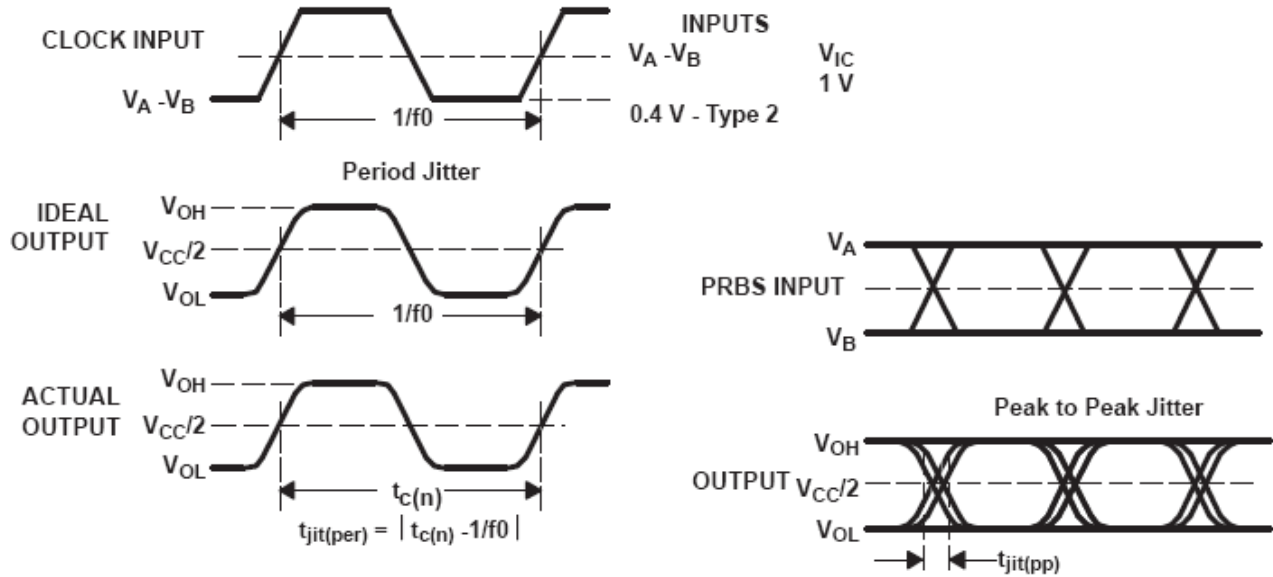

- A. All input pulses are supplied by an Agilent 8304A Stimulus System.
- B. The measurement is made on a TEK TDS6604 running TDSJIT3 application software
- C. Period jitter is measured using a 100 MHz 50 ±1% duty cycle clock input.
- D. Peak-to-peak jitter is measured using a 200 Mbps 2¹⁵-1 PRBS input.

Figure 14. Receiver Jitter Measurement Waveforms

Table 8. TYPE-2 RECEIVER INPUT THRESHOLD TEST VOLTAGES

| Applied Voltages | | Resulting Differential Input Voltage | Resulting Common-Mode Input Voltage | Receiver Output (Note) |
|------------------|--------|--------------------------------------|-------------------------------------|-------------------------|
| VIA | VIB | VID | VIC | |
| 2.400 | 0.000 | 2.400 | 1.200 | H |
| 0.000 | 2.400 | -2.400 | 1.200 | L |
| 3.800 | 3.650 | 0.150 | 3.725 | H |
| 3.800 | 3.750 | 0.050 | 3.775 | L |
| -1.250 | -1.400 | 0.150 | -1.325 | H |
| -1.350 | -1.400 | 0.050 | -1.375 | L |

H = high level, L = low level, output state assumes receiver is enabled ($\overline{RE} = L$)

NBA3N206S

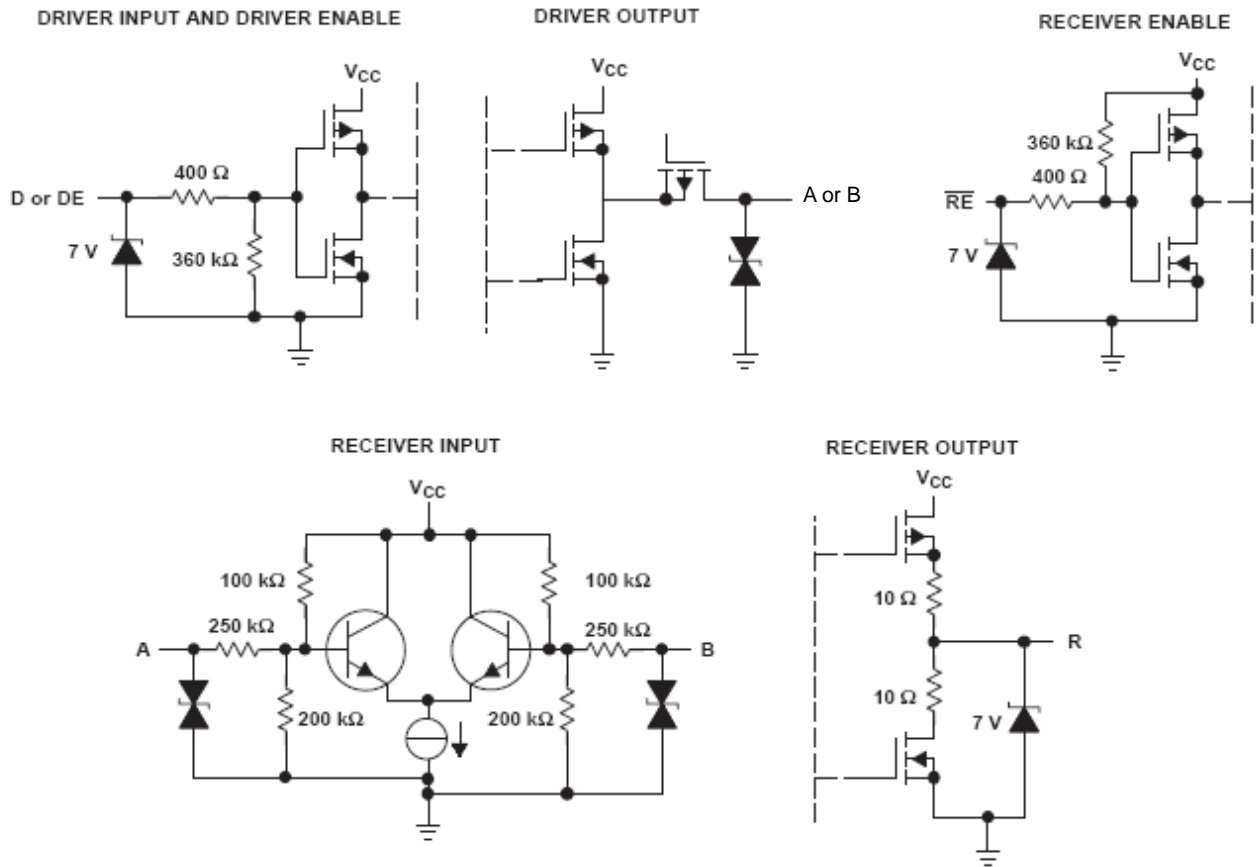

Figure 15. Equivalent Input and Output Schematic Diagrams

APPLICATION INFORMATION

Receiver Input Threshold (Failsafe)

The MLVDS standard defines a type 1 and type 2 receiver. Type 1 receivers include no provisions for failsafe and have their differential input voltage thresholds near zero volts.

Type 2 receivers have their differential input voltage thresholds offset from zero volts to detect the absence of a voltage difference. The impact to receiver output by the offset input can be seen in Table 9 and Figure 16.

Table 9. RECEIVER INPUT VOLTAGE THRESHOLD REQUIREMENTS

| Receiver Type | Output Low | Output High |
|---------------|---|---|
| Type 1 | $-2.4\text{ V} \leq \text{VID} \leq -0.05\text{ V}$ | $0.05\text{ V} \leq \text{VID} \leq 2.4\text{ V}$ |
| Type 2 | $-2.4\text{ V} \leq \text{VID} \leq 0.05\text{ V}$ | $0.15\text{ V} \leq \text{VID} \leq 2.4\text{ V}$ |

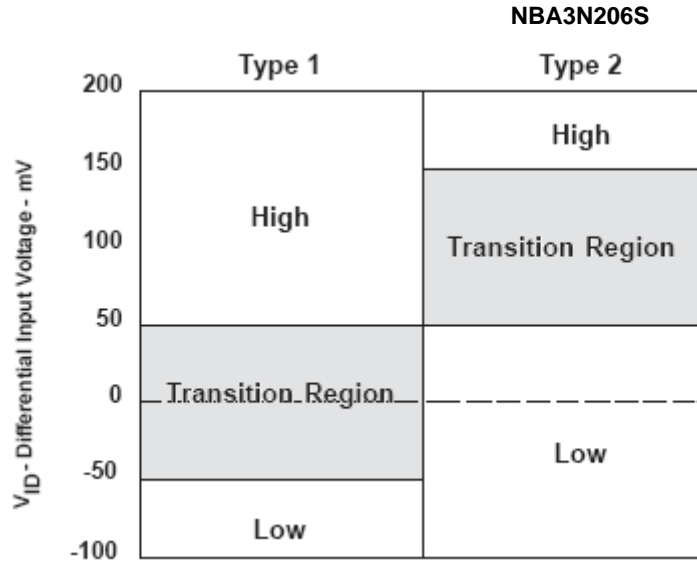

Figure 16. Receiver Differential Input Voltage Showing Transition Regions by Type

LIVE INSERTION/GLITCH-FREE POWER UP/DOWN

The NBA3N206S provides a glitch-free power up/down feature that prevents the M-LVDS outputs of the device from turning on during a power up or power down event. This is especially important in live insertion applications, when a device is physically connected to an M-LVDS multipoint bus and V_{CC} is ramping.

While the M-LVDS interface for these devices is glitch free on power up/down, the receiver output structure is not.

Figure 17 shows the performance of the receiver output pin, R (CHANNEL 2), as V_{CC} (CHANNEL 1) is ramped. The glitch on the R pin is independent of the RE voltage. Any complications or issues from this glitch are easily resolved in power sequencing or system requirements that suspend operation until V_{CC} has reached a steady state value.



Figure 17. M-LVDS Receiver Output: VCC (CHANNEL 1), R Pin (CHANNEL 2)

Simplex Theory Configurations: Data flow is unidirectional and Point-to-Point from one Driver to one Receiver. NBA3N206S devices provide a high signal current allowing long drive runs and high noise immunity. Single terminated interconnects yield high amplitude levels.

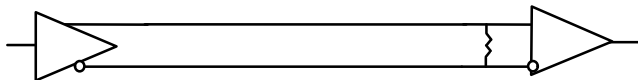

Figure 18. Point-to-Point Simplex Single Termination

Parallel terminated interconnects yield typical MLVDS amplitude levels and minimizes reflections. See Figures 18 and 19. A NBA3N206S can be used as the driver or as a receiver.

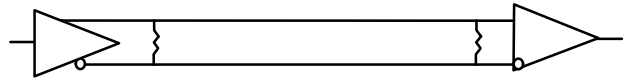

Figure 19. Parallel-Terminated Simplex

Simplex Multidrop Theory Configurations: Data flow is unidirectional from one Driver with one or more Receivers. Multiple boards required. Single terminated interconnects yield high amplitude levels. Parallel terminated interconnects yield typical MLVDS amplitude levels and

minimizes reflections. On the Evaluation Test Board, Headers P1, P2, and P3 may be used as need to interconnect transceivers to a each other or a bus. See Figures 20 and 21. A NBA3N206S can be used as the driver or as a receiver.

NBA3N206S



Figure 20. Multidrop or Distributed Simplex with Single Termination

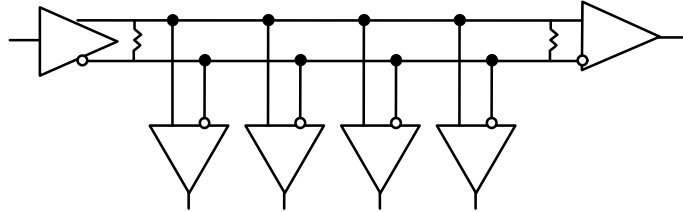

Figure 21. Multidrop or Distributed Simplex with Double Termination

Half Duplex Multinode Multipoint Theory Configurations: Data flow is unidirectional and selected from one of multiple possible Drivers to multiple Receivers. One “Two Node” multipoint connection can be accomplished with a single evaluation test board. More than Two Nodes requires multiple evaluation test boards. Parallel terminated interconnects yield typical MLVDS amplitude

levels and minimizes reflections. Parallel terminated interconnects yield typical LMVDS amplitude levels and minimizes reflections. On the Test Board, Headers P1, P2, and P3 may be used as need to interconnect transceivers to each other or a bus. See Figure 22. A NBA3N206SDG can be used as the driver or as a receiver.

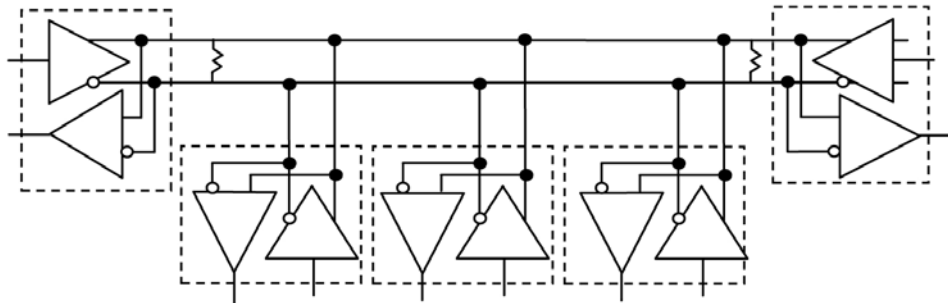

Figure 22. Multinode Multipoint Half Duplex (requires Double Termination)

QUADRANT ASSIGNMENTS FOR PIN 1 ORIENTATION IN TAPE

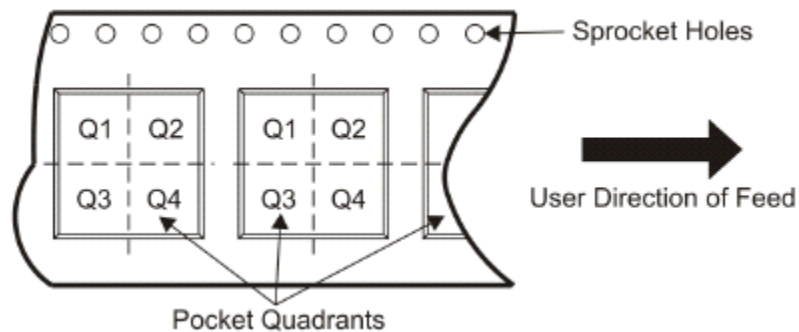

Figure 23.

NBA3N206S

ORDERING INFORMATION

| Device | Receiver | Pin 1 Quadrant | Package | Shipping† |
|---------------|----------|----------------|-----------------------|--------------------|
| NBA3N206SDG | Type 2 | Q1 | SOIC – 8 (Pb-Free) | 98 Units / Rail |
| NBA3N206SDR2G | Type 2 | Q1 | SOIC – 8 (Pb-Free) | 2500 / Tape & Reel |

†For information on tape and reel specifications, including part orientation and tape sizes, please refer to our Tape and Reel Packaging Specifications Brochure, BRD8011/D.

NBA3N206S

PACKAGE DIMENSIONS

SOIC-8 NB
CASE 751-07
ISSUE AK

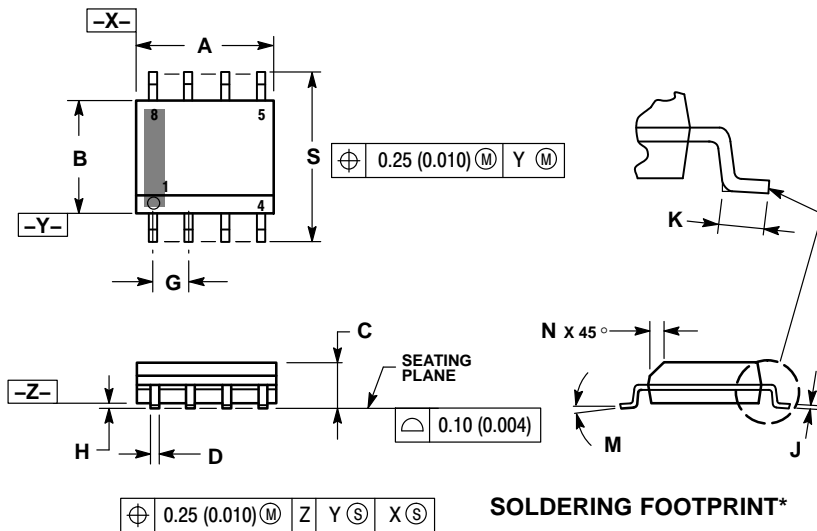

NOTES:

1. DIMENSIONING AND TOLERANCING PER ANSI Y14.5M, 1982.
2. CONTROLLING DIMENSION: MILLIMETER.
3. DIMENSION A AND B DO NOT INCLUDE MOLD PROTRUSION.
4. MAXIMUM MOLD PROTRUSION 0.15 (0.006) PER SIDE.
5. DIMENSION D DOES NOT INCLUDE DAMBAR PROTRUSION. ALLOWABLE DAMBAR PROTRUSION SHALL BE 0.127 (0.005) TOTAL IN EXCESS OF THE D DIMENSION AT MAXIMUM MATERIAL CONDITION.
6. 751-01 THRU 751-06 ARE OBSOLETE. NEW STANDARD IS 751-07.

| DIM | MILLIMETERS | | INCHES | |
|-----|-------------|------|-----------|-------|
| | MIN | MAX | MIN | MAX |
| A | 4.80 | 5.00 | 0.189 | 0.197 |
| B | 3.80 | 4.00 | 0.150 | 0.157 |
| C | 1.35 | 1.75 | 0.053 | 0.069 |
| D | 0.33 | 0.51 | 0.013 | 0.020 |
| G | 1.27 BSC | | 0.050 BSC | |
| H | 0.10 | 0.25 | 0.004 | 0.010 |
| J | 0.19 | 0.25 | 0.007 | 0.010 |
| K | 0.40 | 1.27 | 0.016 | 0.050 |
| M | 0° | 8° | 0° | 8° |
| N | 0.25 | 0.50 | 0.010 | 0.020 |
| S | 5.80 | 6.20 | 0.228 | 0.244 |

SOLDERING FOOTPRINT*

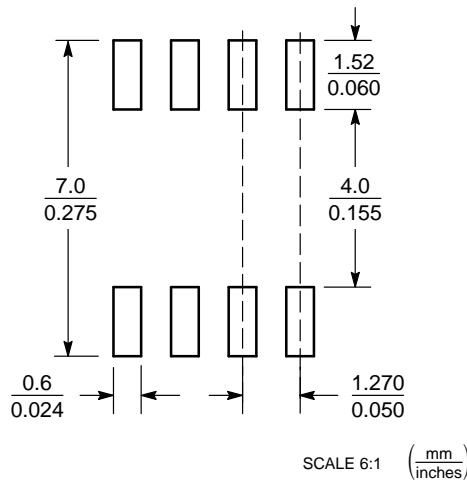

*For additional information on our Pb-Free strategy and soldering details, please download the ON Semiconductor Soldering and Mounting Techniques Reference Manual, SOLDERRM/D.

ON Semiconductor and the are registered trademarks of Semiconductor Components Industries, LLC (SCILLC) or its subsidiaries in the United States and/or other countries. SCILLC owns the rights to a number of patents, trademarks, copyrights, trade secrets, and other intellectual property. A listing of SCILLC's product/patent coverage may be accessed at www.onsemi.com/site/pdf/Patent-Marking.pdf. SCILLC reserves the right to make changes without further notice to any products herein. SCILLC makes no warranty, representation or guarantee regarding the suitability of its products for any particular purpose, nor does SCILLC assume any liability arising out of the application or use of any product or circuit, and specifically disclaims any and all liability, including without limitation special, consequential or incidental damages. "Typical" parameters which may be provided in SCILLC data sheets and/or specifications can and do vary in different applications and actual performance may vary over time. All operating parameters, including "Typicals" must be validated for each customer application by customer's technical experts. SCILLC does not convey any license under its patent rights nor the rights of others. SCILLC products are not designed, intended, or authorized for use as components in systems intended for surgical implant into the body, or other applications intended to support or sustain life, or for any other application in which the failure of the SCILLC product could create a situation where personal injury or death may occur. Should Buyer purchase or use SCILLC products for any such unintended or unauthorized application, Buyer shall indemnify and hold SCILLC and its officers, employees, subsidiaries, affiliates, and distributors harmless against all claims, costs, damages, and expenses, and reasonable attorney fees arising out of, directly or indirectly, any claim of personal injury or death associated with such unintended or unauthorized use, even if such claim alleges that SCILLC was negligent regarding the design or manufacture of the part. SCILLC is an Equal Opportunity/Affirmative Action Employer. This literature is subject to all applicable copyright laws and is not for resale in any manner.

PUBLICATION ORDERING INFORMATION

LITERATURE FULFILLMENT:
Literature Distribution Center for ON Semiconductor
P.O. Box 5163, Denver, Colorado 80217 USA
Phone: 303-675-2175 or 800-344-3860 Toll Free USA/Canada
Fax: 303-675-2176 or 800-344-3867 Toll Free USA/Canada
Email: orderlit@onsemi.com

N. American Technical Support: 800-282-9855 Toll Free USA/Canada
Europe, Middle East and Africa Technical Support:
Phone: 421 33 790 2910
Japan Customer Focus Center
Phone: 81-3-5817-1050

ON Semiconductor Website: www.onsemi.com
Order Literature: <http://www.onsemi.com/orderlit>

For additional information, please contact your local Sales Representative



Компания «ЭлектроПласт» предлагает заключение долгосрочных отношений при поставках импортных электронных компонентов на взаимовыгодных условиях!

Наши преимущества:

- Оперативные поставки широкого спектра электронных компонентов отечественного и импортного производства напрямую от производителей и с крупнейших мировых складов;
- Поставка более 17-ти миллионов наименований электронных компонентов;
- Поставка сложных, дефицитных, либо снятых с производства позиций;
- Оперативные сроки поставки под заказ (от 5 рабочих дней);
- Экспресс доставка в любую точку России;
- Техническая поддержка проекта, помощь в подборе аналогов, поставка прототипов;
- Система менеджмента качества сертифицирована по Международному стандарту ISO 9001;
- Лицензия ФСБ на осуществление работ с использованием сведений, составляющих государственную тайну;
- Поставка специализированных компонентов (Xilinx, Altera, Analog Devices, Intersil, Interpoint, Microsemi, Aeroflex, Peregrine, Syfer, Eurofarad, Texas Instrument, Miteq, Cobham, E2V, MA-COM, Hittite, Mini-Circuits, General Dynamics и др.);

Помимо этого, одним из направлений компании «ЭлектроПласт» является направление «Источники питания». Мы предлагаем Вам помощь Конструкторского отдела:

- Подбор оптимального решения, техническое обоснование при выборе компонента;
- Подбор аналогов;
- Консультации по применению компонента;
- Поставка образцов и прототипов;
- Техническая поддержка проекта;
- Защита от снятия компонента с производства.



Как с нами связаться

Телефон: 8 (812) 309 58 32 (многоканальный)

Факс: 8 (812) 320-02-42

Электронная почта: org@eplast1.ru

Адрес: 198099, г. Санкт-Петербург, ул. Калинина, дом 2, корпус 4, литера А.