

## Summary

The ZABG6003 is an advanced GaAs and HEMT FETs bias controller designed to operate from minimal supply rails and intended primarily for satellite Low Noise Blocks (LNBs). With the addition of one capacitor and a resistor, the ZABG6003 provides drain voltage and current control for up to 6 external grounded source FETs. Generating the regulated negative rail required for FET gate biasing whilst operating from a single supply of 2.1V to 5V. The -2V negative bias can also be used to supply other external circuits.

Setting drain currents on the ZABG6003 only requires one resistor which controls the drain current of the first stage FETS (D1 and D4). The drain current is set internally to 10mA for the remaining 4 FETS for the second and third stages. This allows the operating current of input FETs to be adjusted to minimize noise, whilst the following FET stages are fixed to minimize the number of external components used.

## Features

- Provides Bias for up to 6 GaAs and HEMT FETs
  - 2 x Amplifier FET Drain Current Programmable (4mA to 15mA)
  - 4 x Amplifier FET Drain Current Internally Fixed to 10mA
- Operating Range of 2.1V to 5V
- Ultra-low Operating Current of 1.1mA
- Dynamic FET Protection
- Regulated Negative Rail Generator Requires only 1 External Capacitor
- Expanded Temperature Range of -40°C to +105°C
- U-QFN3030-16 (Type B) Surface Mount Package
- Low External Component Count
- **Totally Lead-Free & Fully RoHS Compliant (Notes 1 & 2)**
- **Halogen and Antimony Free. "Green" Device (Note 3)**

## Applications

- Low Power LNB's
- Digital LNB's
- IP LNB's
- Twin and Quad LNB's
- General Purpose LNA Bias

- Notes:
1. No purposely added lead. Fully EU Directive 2002/95/EC (RoHS) & 2011/65/EU (RoHS 2) compliant.
  2. See [http://www.diodes.com/quality/lead\\_free.html](http://www.diodes.com/quality/lead_free.html) for more information about Diodes Incorporated's definitions of Halogen- and Antimony-free, "Green" and Lead-free.
  3. Halogen- and Antimony-free "Green" products are defined as those which contain <900ppm bromine, <900ppm chlorine (<1500ppm total Br + Cl) and <1000ppm antimony compounds.

## Twin LNB System Diagrams

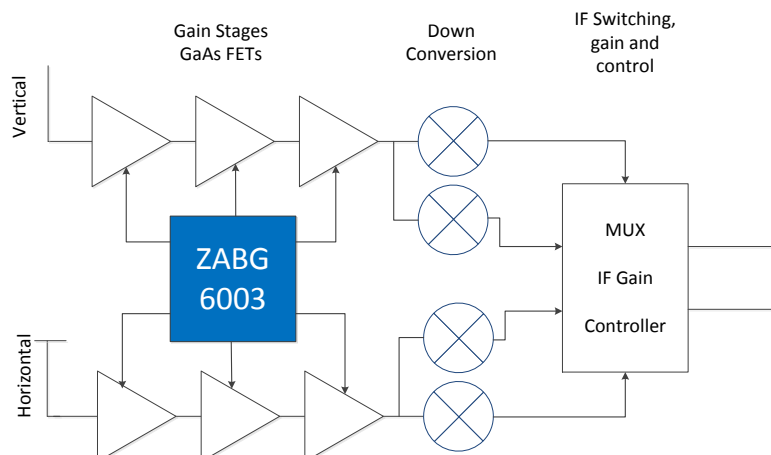

## Device Description

The ZABG series of devices are designed to meet the bias requirements of GaAs and HEMT FETs commonly used in satellite receiver LNAs with a minimum of external components whilst operating from a minimal voltage supply and using minimal current.

The ZABG6003 has six FET bias stages. To optimize the system for noise and gain the drain current for two of the six stages can be programmed over the range of 4mA to 15mA. Programming the drain current of FETS D1 and D4 is achieved by a resistor connected to the R<sub>CAL1</sub> pin. The Drain current of the remaining four FETS D2, D3, D5 and D6 are internally set to 10mA.

Drain voltages of amplifier stages are set at 2.0V and are current limited to approximately current set by their associated R<sub>CAL</sub> resistors.

Depletion mode FETs require a negative voltage bias supply when operated in grounded source circuits. The ZABG6003 includes an integrated switched capacitor DC-DC converter generating a regulated output of -2V to allow single supply operation. The ZABG6003 has been designed to be used with supply rails of 2.1V to 5.0V and the V<sub>DD</sub> range has been extended to 5.5V to allow for 10% supply variation.

It is possible to use less than the full complement of FET bias controls, unused drain and gate connections can be left open circuit without affecting operation of the remaining bias circuits.

To protect the external FETs the circuits have been designed to ensure that, under any conditions including power up/down transients, the gate drive from the bias circuits cannot exceed -2.5V. Additionally each stage has its own individual current limiter. Furthermore if the negative rail experiences a fault condition, such as overload or short circuit, the drain supply to the FETs will be limited, avoiding excessive current flow.

The ZABG6003 is available in the U-QFN3030-16 (Type B) package.

Device operating temperature is -40°C to +105°C to suit a wide range of environmental conditions.

## Pin Assignments and Descriptions

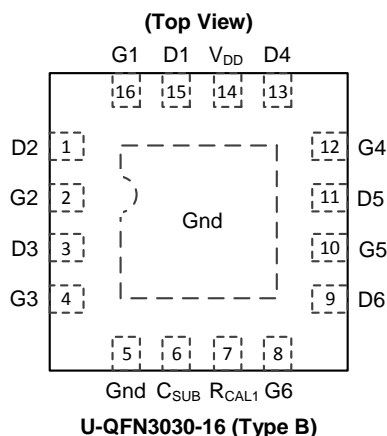

Pin Number	Pin Name	Description
1	D2	Drain GaAs FET 2
2	G2	Gate GaAs FET 2
3	D3	Drain GaAs FET 3
4	G3	Gate GaAs FET 3
5	Gnd	Ground
6	C <sub>SUB</sub>	Negative rail reservoir capacitor
7	R <sub>CAL1</sub>	Drain current setting for D1 and D4
8	G6	Gate GaAs FET 6
9	D6	Drain GaAs FET 6
10	G5	Gate GaAs FET 5
11	D5	Drain GaAs FET 5
12	G4	Gate GaAs FET 4
13	D4	Drain GaAs FET 4
14	V <sub>DD</sub>	Supply voltage
15	D1	Drain GaAs FET 1
16	G1	Gate GaAs FET 1
Pad	Gnd	Must be connected to Ground or No Connection

## Maximum Ratings

Symbol	Parameter	Rating	Unit
$V_{DD}$	Supply Voltage	-0.6 to +6	V
$I_{DD}$	Supply Current	100	mA
—	Power Dissipation U-QFN3030-16 (Type B)	650	mW
$T_J$	Junction Temperature	+135	°C
$T_{STG}$	Storage Temperature Range	-40 to +150	°C

## Recommended Operating Conditions (Note 8)

Symbol	Parameter	Min	Max	Unit
$V_{DD}$	Operating Voltage Range	2.1	5.5	V
$T_A$	Operating Temperature Range	-40	+105	°C

## Electrical Characteristics (@ $T_A = +25^\circ\text{C}$ , $V_{DD} = 2.3\text{V}$ , $I_{D1}$ to $I_{D6}$ set to 10mA.)

Symbol	Parameter	Conditions	Min	Typ	Max	Unit
$I_{DD}$	Supply Current	$I_{D1-6} = 0$	—	1.1	2.5	mA
$I_{DD(L)}$		$I_{D1-6} = 10\text{mA}$	—	—	65	mA
$V_{CSUB}$	Substrate Voltage (Note 5)	$I_{CSUB} = 0$	-2.5	-2.0	-1.5	V
$V_{CSUB(L)}$		$I_{CSUB} = -20\mu\text{A}$	—	—	-1.5	V
$f_{OSC}$	Oscillator Frequency	—	—	7.5	—	MHz
$V_{D(NOISE)}$	Drain Voltage (Note 6)	$C_{GATE-GND} = 10\text{nF}$ $C_{DRAIN-GND} = 10\text{nF}$	—	—	0.02	$V_{PK-PK}$
$V_{G(NOISE)}$	Gate Voltage (Note 6)	$C_{GATE-GND} = 10\text{nF}$ $C_{DRAIN-GND} = 10\text{nF}$	—	—	0.005	$V_{PK-PK}$

### Gate Characteristics

#### Gate (G1 to G6)

$I_G$	Current Range	—	-50	—	60	$\mu\text{A}$
$V_{G(L)}$	Voltage Low	$I_D = 12\text{mA}$ , $I_G = -10\mu\text{A}$	-2.5	-2.0	-1.5	V
$V_{G(H)}$	Voltage High	$I_D = 8\text{mA}$ , $I_G = 0$	0	0.7	1.0	V

### Drain Characteristics

#### Drain (D1 to D6)

$I_D$	Current Range	D1 and D4	4	—	15	mA
$I_{DD}$		D2, D3, D5, D6 Internally Fixed	10			mA
$I_{D(OP)}$	Current Operating (Note 4)	Standard Application Circuit	8	10	12	mA
$V_{D(OP)}$	Voltage Operating (Note 7)	$I_D = 10\text{mA}$	1.8	2.0	2.2	V
$dV_D/dV_{DD}$	delta $V_D$ vs $V_{DD}$	$V_{DD} = 2.3\text{V}$ to $5.5\text{V}$	—	0.075	—	%/V
$dI_D/dV_{DD}$	delta $I_D$ vs $V_{DD}$	$V_{DD} = 2.3\text{V}$ to $5.5\text{V}$	—	0.7	—	%/V
$dV_D/dT_A$	delta $V_D$ vs $T_A$	$T_A = -40^\circ\text{C}$ to $+105^\circ\text{C}$	—	150	—	ppm

- Notes:
- Characteristics are measured using one external reference resistor,  $R_{CAL1}$ .
  - The negative bias voltages are generated on-chip using an internal oscillator. An external 47nF capacitor is required for this purpose.
  - Noise voltage measurements are made with FETs and gate and drain capacitors of value 10nF in place. Noise voltages are not measured in production.
  - The maximum operating drain voltage is equal to  $V_{DD}$  or  $V_{D(OP)}$  max whichever is lower.
  - ESD sensitive, handling precautions are recommended.

**Typical Characteristics** (@ $T_A = +25^\circ\text{C}$ ,  $V_{DD} = 2.3\text{V}$ ,  $I_{D1}$  to  $I_{D6}$  set to 10mA (setting  $I_D$  to 10mA), unless otherwise stated.)

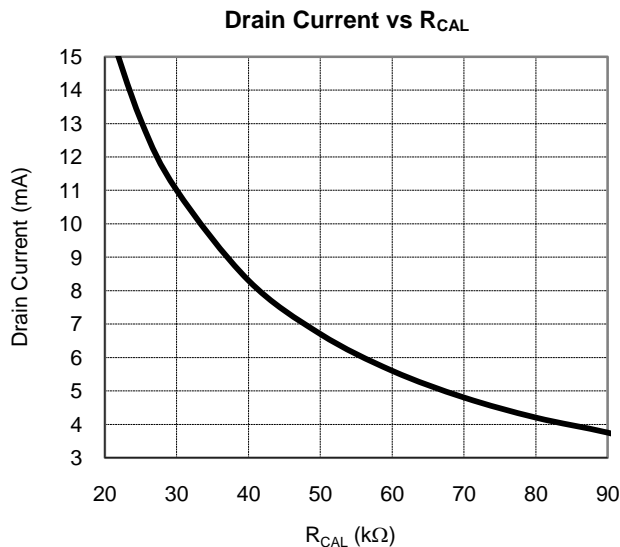
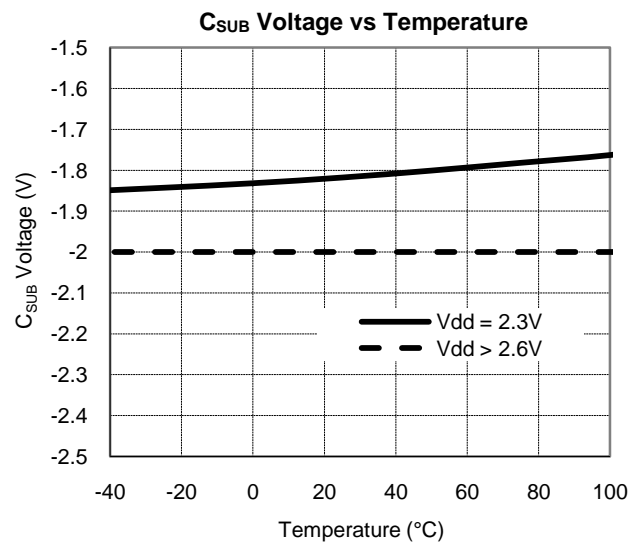
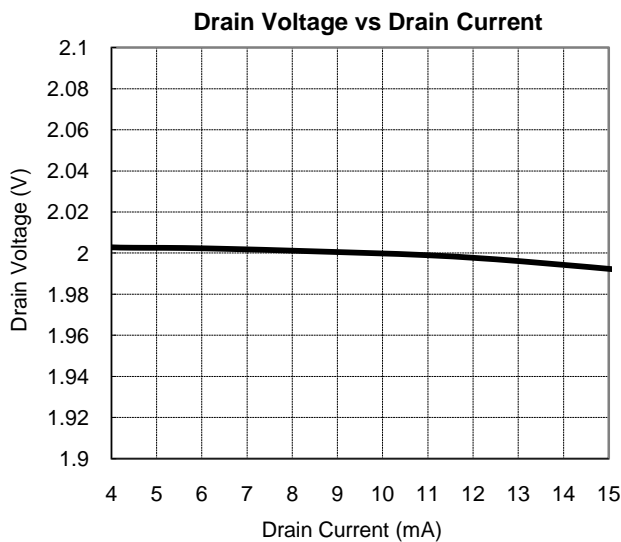
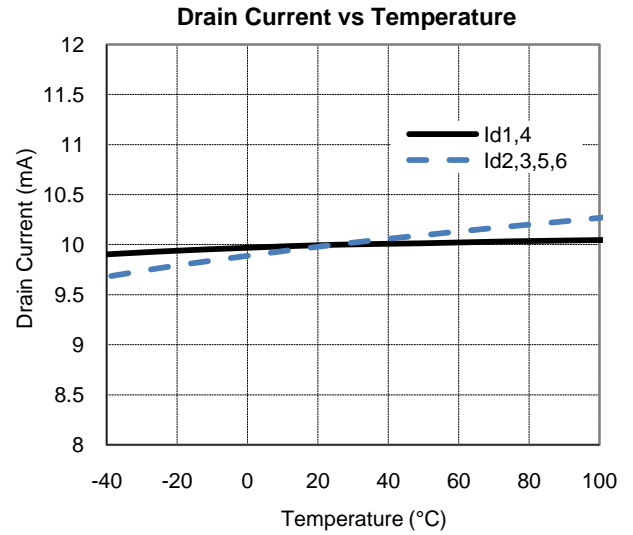
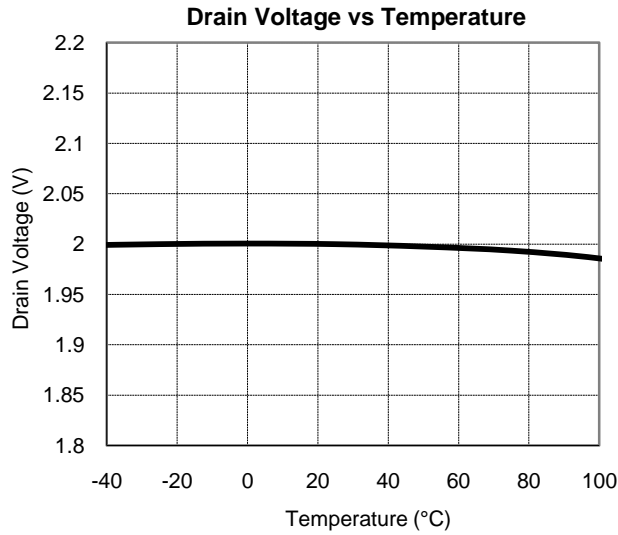

## Application Information

Below is a partial applications circuit for the ZABG6003 showing all external components needed for biasing one of the six FET stages available as a typical LNA (Low Noise Amplifier). Each bias stage is provided with a gate and drain pin. The drain pin provides a regulated 2.0V supply that includes a drain current monitor. The drain current taken by the external FET is compared with a user selected level, generating a signal that adjusts the gate voltage of the FET to obtain the required drain current. If for any reason, an attempt is made to draw more than the user set drain current from the drain pin, the drain voltage will be reduced to ensure excess current is not taken. The gate pin drivers are also current limited.

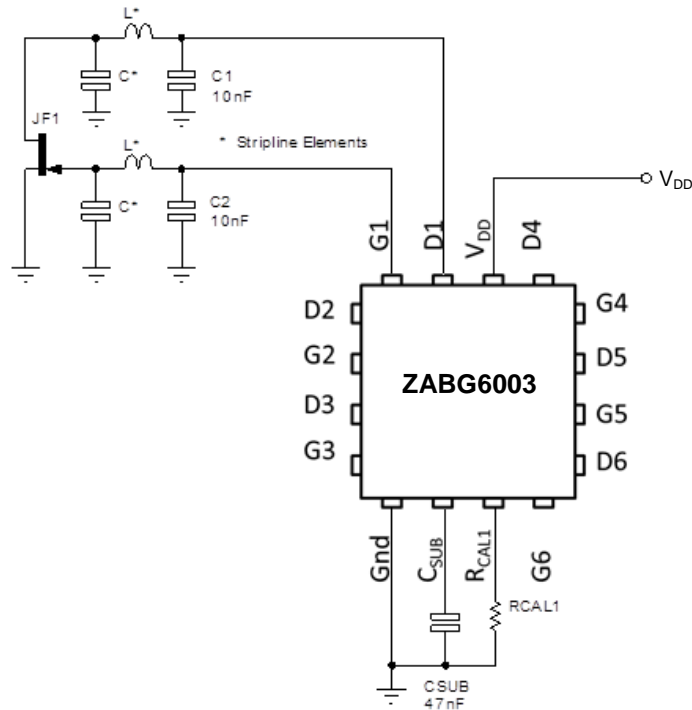

The bias stages are split up into two groups, with the drain current for D1 and D4 set by an external  $R_{CAL1}$  resistor within the range of 4mA to 15mA. Drain currents for D2, D3, D5 and D6 are internally fixed to 10mA. This allows the optimization of drain currents for differing tasks such as input stages where noise can be critical and later amplifier stages where gain may be more important. A graph showing the relationship between the value of  $R_{CAL}$  and  $I_D$  is provided in the Typical Characteristics section of this datasheet.

The ZABG6003 includes a switched capacitor DC-DC converter that is used to generate the negative supply required to bias depletion mode FETs used in common source circuit configuration as shown above. This converter uses an external capacitor  $C_{SUB}$  as the output reservoir capacitor. The circuit provides a regulated -2V supply both for gate driver use and for external use if required (for extra discrete bias stages, mixer bias, local oscillator bias etc.). The -2V supply is available from the  $C_{SUB}$  pin.

If any bias stages are not required, their gate and drain pins may be left open circuit. If all bias stages associated with a  $R_{CAL}$  resistor are not required, then this resistor may be omitted. The Gnd flag on the underside of the DFN package can be connected to Gnd or left open circuit.

**Ordering Information**

Part Number	Package	Reel Size (inches)	Tape Width (mm)	Quantity Per Reel
ZABG6003JA16TC	U-QFN3030-16 (Type B)	13	12	3,000

**Marking Information**

U-QFN3030-16 (Type B)

(Top View)

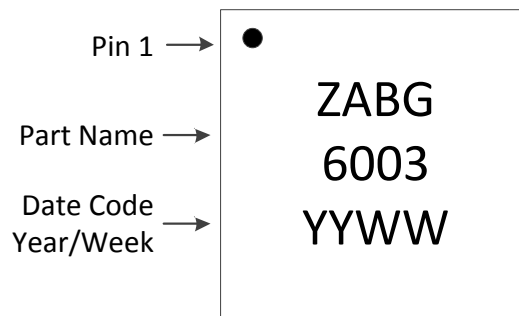

NEW PRODUCT

**Package Outline Dimensions**

Please see <http://www.diodes.com/package-outlines.html> for the latest version.

**U-QFN3030-16 (Type B)**

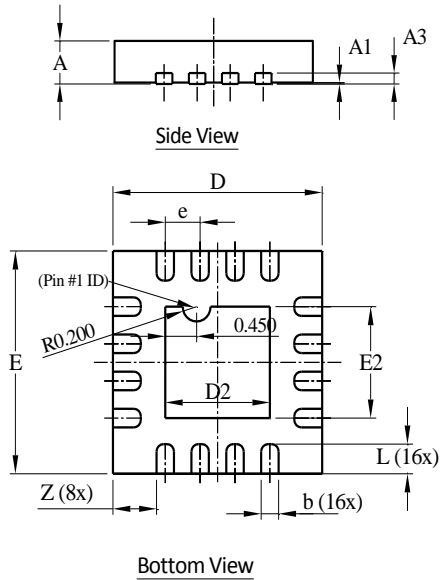

U-QFN3030-16 Type B			
Dim	Min	Max	Typ
A	0.55	0.65	0.60
A1	0	0.05	0.02
A3	-	-	0.15
b	0.18	0.28	0.23
D	2.95	3.05	3.00
D2	1.40	1.60	1.50
E	2.95	3.05	3.00
E2	1.40	1.60	1.50
e	-	-	0.50
L	0.35	0.45	0.40
Z	-	-	0.625
All Dimensions in mm			

**Suggested Pad Layout**

Please see <http://www.diodes.com/package-outlines.html> for the latest version.

**U-QFN3030-16 (Type B)**

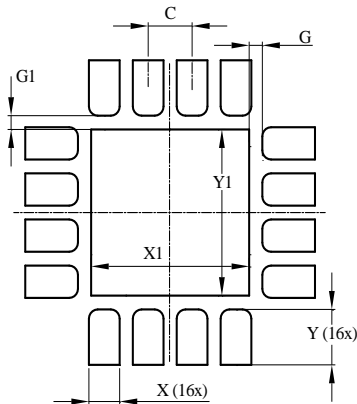

Dimensions	Value (in mm)
C	0.500
G	0.150
G1	0.150
X	0.350
X1	1.800
Y	0.600
Y1	1.800

NEW PRODUCT

**IMPORTANT NOTICE**

DIODES INCORPORATED MAKES NO WARRANTY OF ANY KIND, EXPRESS OR IMPLIED, WITH REGARDS TO THIS DOCUMENT, INCLUDING, BUT NOT LIMITED TO, THE IMPLIED WARRANTIES OF MERCHANTABILITY AND FITNESS FOR A PARTICULAR PURPOSE (AND THEIR EQUIVALENTS UNDER THE LAWS OF ANY JURISDICTION).

Diodes Incorporated and its subsidiaries reserve the right to make modifications, enhancements, improvements, corrections or other changes without further notice to this document and any product described herein. Diodes Incorporated does not assume any liability arising out of the application or use of this document or any product described herein; neither does Diodes Incorporated convey any license under its patent or trademark rights, nor the rights of others. Any Customer or user of this document or products described herein in such applications shall assume all risks of such use and will agree to hold Diodes Incorporated and all the companies whose products are represented on Diodes Incorporated website, harmless against all damages.

Diodes Incorporated does not warrant or accept any liability whatsoever in respect of any products purchased through unauthorized sales channel. Should Customers purchase or use Diodes Incorporated products for any unintended or unauthorized application, Customers shall indemnify and hold Diodes Incorporated and its representatives harmless against all claims, damages, expenses, and attorney fees arising out of, directly or indirectly, any claim of personal injury or death associated with such unintended or unauthorized application.

Products described herein may be covered by one or more United States, international or foreign patents pending. Product names and markings noted herein may also be covered by one or more United States, international or foreign trademarks.

This document is written in English but may be translated into multiple languages for reference. Only the English version of this document is the final and determinative format released by Diodes Incorporated.

**LIFE SUPPORT**

Diodes Incorporated products are specifically not authorized for use as critical components in life support devices or systems without the express written approval of the Chief Executive Officer of Diodes Incorporated. As used herein:

A. Life support devices or systems are devices or systems which:

1. are intended to implant into the body, or
2. support or sustain life and whose failure to perform when properly used in accordance with instructions for use provided in the labeling can be reasonably expected to result in significant injury to the user.

B. A critical component is any component in a life support device or system whose failure to perform can be reasonably expected to cause the failure of the life support device or to affect its safety or effectiveness.

Customers represent that they have all necessary expertise in the safety and regulatory ramifications of their life support devices or systems, and acknowledge and agree that they are solely responsible for all legal, regulatory and safety-related requirements concerning their products and any use of Diodes Incorporated products in such safety-critical, life support devices or systems, notwithstanding any devices- or systems-related information or support that may be provided by Diodes Incorporated. Further, Customers must fully indemnify Diodes Incorporated and its representatives against any damages arising out of the use of Diodes Incorporated products in such safety-critical, life support devices or systems.

Copyright © 2016, Diodes Incorporated

[www.diodes.com](http://www.diodes.com)





Компания «ЭлектроПласт» предлагает заключение долгосрочных отношений при поставках импортных электронных компонентов на взаимовыгодных условиях!

Наши преимущества:

- Оперативные поставки широкого спектра электронных компонентов отечественного и импортного производства напрямую от производителей и с крупнейших мировых складов;
- Поставка более 17-ти миллионов наименований электронных компонентов;
- Поставка сложных, дефицитных, либо снятых с производства позиций;
- Оперативные сроки поставки под заказ (от 5 рабочих дней);
- Экспресс доставка в любую точку России;
- Техническая поддержка проекта, помощь в подборе аналогов, поставка прототипов;
- Система менеджмента качества сертифицирована по Международному стандарту ISO 9001;
- Лицензия ФСБ на осуществление работ с использованием сведений, составляющих государственную тайну;
- Поставка специализированных компонентов (Xilinx, Altera, Analog Devices, Intersil, Interpoint, Microsemi, Aeroflex, Peregrine, Syfer, Eurofarad, Texas Instrument, Miteq, Cobham, E2V, MA-COM, Hittite, Mini-Circuits, General Dynamics и др.);

Помимо этого, одним из направлений компании «ЭлектроПласт» является направление «Источники питания». Мы предлагаем Вам помощь Конструкторского отдела:

- Подбор оптимального решения, техническое обоснование при выборе компонента;
- Подбор аналогов;
- Консультации по применению компонента;
- Поставка образцов и прототипов;
- Техническая поддержка проекта;
- Защита от снятия компонента с производства.



#### Как с нами связаться

**Телефон:** 8 (812) 309 58 32 (многоканальный)

**Факс:** 8 (812) 320-02-42

**Электронная почта:** [org@eplast1.ru](mailto:org@eplast1.ru)

**Адрес:** 198099, г. Санкт-Петербург, ул. Калинина, дом 2, корпус 4, литера А.