



Intel® NUC Board NUC7i3BNB

Technical Product Specification

October 2017

Order Number: J52707-006

Intel NUC Board NUC7i3BNB may contain design defects or errors known as errata that may cause the product to deviate from published specifications. Current characterized errata, if any, are documented in Intel NUC Board NUC7i3BNB Specification Update.

Revision History

Revision	Revision History	Date
001	First release of the Intel NUC Board NUC7i3BNB Technical Product Specification	January 2017
002	Specification Change	May 2017
003	Specification Change	June 2017
004	Specification Change	June 2017
005	Specification Change	June 2017
006	Specification Change	October 2017

Disclaimer

This product specification applies to only the standard Intel NUC Board with BIOS identifier BNKBL357.86A.

INFORMATION IN THIS DOCUMENT IS PROVIDED IN CONNECTION WITH INTEL® PRODUCTS. NO LICENSE, EXPRESS OR IMPLIED, BY ESTOPPEL OR OTHERWISE, TO ANY INTELLECTUAL PROPERTY RIGHTS IS GRANTED BY THIS DOCUMENT. EXCEPT AS PROVIDED IN INTEL'S TERMS AND CONDITIONS OF SALE FOR SUCH PRODUCTS, INTEL ASSUMES NO LIABILITY WHATSOEVER, AND INTEL DISCLAIMS ANY EXPRESS OR IMPLIED WARRANTY, RELATING TO SALE AND/OR USE OF INTEL PRODUCTS INCLUDING LIABILITY OR WARRANTIES RELATING TO FITNESS FOR A PARTICULAR PURPOSE, MERCHANTABILITY, OR INFRINGEMENT OF ANY PATENT, COPYRIGHT OR OTHER INTELLECTUAL PROPERTY RIGHT. UNLESS OTHERWISE AGREED IN WRITING BY INTEL, THE INTEL PRODUCTS ARE NOT DESIGNED NOR INTENDED FOR ANY APPLICATION IN WHICH THE FAILURE OF THE INTEL PRODUCT COULD CREATE A SITUATION WHERE PERSONAL INJURY OR DEATH MAY OCCUR.

All Intel NUC Boards are evaluated as Information Technology Equipment (I.T.E.) for use in personal computers (PC) for installation in homes, offices, schools, computer rooms, and similar locations. The suitability of this product for other PC or embedded non-PC applications or other environments, such as medical, industrial, alarm systems, test equipment, etc. may not be supported without further evaluation by Intel.

Intel Corporation may have patents or pending patent applications, trademarks, copyrights, or other intellectual property rights that relate to the presented subject matter. The furnishing of documents and other materials and information does not provide any license, express or implied, by estoppel or otherwise, to any such patents, trademarks, copyrights, or other intellectual property rights.

Intel may make changes to specifications and product descriptions at any time, without notice.

Designers must not rely on the absence or characteristics of any features or instructions marked "reserved" or "undefined." Intel reserves these for future definition and shall have no responsibility whatsoever for conflicts or incompatibilities arising from future changes to them.

Intel processor numbers are not a measure of performance. Processor numbers differentiate features within each processor family, not across different processor families: Go to:

[Learn About Intel® Processor Numbers](#)

Intel NUC may contain design defects or errors known as errata, which may cause the product to deviate from published specifications. Current characterized errata are available on request.

Contact your local Intel sales office or your distributor to obtain the latest specifications before placing your product order.

Intel, the Intel logo, Intel NUC and Intel Core are trademarks of Intel Corporation in the U.S. and/or other countries.

* Other names and brands may be claimed as the property of others.

The terms HDMI and HDMI High-Definition Multimedia Interface, and the HDMI Logo are trademarks or registered trademarks of HDMI Licensing LLC in the United States and other countries

DisplayPort™ and the DisplayPort™ logo are trademarks owned by the Video Electronics Standards Association (VESA®) in the United States and other countries

Copyright © 2017 Intel Corporation. All rights reserved.

Board Identification Information

Basic Intel® NUC Board NUC7i3BNB Identification Information

AA Revision	BIOS Revision	Notes
J22859-302	BNKBL357.86A	1,2

Notes:

- The AA number is found on a small label on the component side of the board.
- The Intel® Core™ i3-7100U processor used on this AA revision consists of one of the following components:

Device	Stepping	S-Spec Numbers
Intel Core i3	H0	SR343
Intel Core i3	H0	SR2ZW

Product Identification Information

Intel® NUC Products NUC7i3BN{x} Identification Information

Product Name	Intel® NUC Board	Differentiating Features
Intel® NUC Kit NUC7i3BNK	NUC7i3BNB J22859-xxx	Kit with power adapter
Intel® NUC Kit NUC7i3BNH		HDD kit with power adapter
Intel® NUC Kit NUC7i3BNHX1		HDD kit with power adapter, 16GB Intel® Optane™ Module
Intel® NUC Kit NUC7i3BNHXF		HDD kit with power adapter, 16GB Intel® Optane™ Module, 1TB HDD, 4GB DDR4-2400 SDRAM ^[1] , Microsoft* Windows* 10 Home

Notes:

- The maximum supported memory speed of the Intel NUC board NUC7i[x]BNB is 2133 MHz. Memory modules of higher speeds will be down-clocked to 2133 MHz.

Specification Changes or Clarifications

The table below indicates the Specification Changes or Specification Clarifications that apply to the Intel NUC Board NUC7i3BNB.

Specification Changes or Clarifications

Date	Type of Change	Description of Changes or Clarifications
May 2017	Spec Change	Remove reference to "RAID 0 auto replace" in the 1.7.3 Intel® Rapid Storage Technology / SATA RAID section.
June 2017	Spec Change	<ul style="list-style-type: none"> Change all references of HDMI 2.0 to HDMI 2.0a: On page 13 in the audio section On page 23 in section 1.5.1.3 On page 25 in section 1.5.1.5 <p>On page 3, change the Product Identification matrix to include a new row for NUC7i3BNHX1</p>

June 2017	Spec Change	Revised step 3 of "Power Button Menu" section
June 2017	Spec Change	Corrected block diagram in Figure 3
October 2017	Spec Change	<ul style="list-style-type: none">• Updated Product Identification table• Updated section 1.5.1.7 "Integrated Audio Provided by the HDMI..." to change 192Khz/24 bit to "176.4kHz/24 bit

Errata

Current characterized errata, if any, are documented in a separate Specification Update. See <http://www.intel.com/content/www/us/en/nuc/overview.html> for the latest documentation.

Preface

This Technical Product Specification (TPS) specifies the board layout, components, connectors, power and environmental requirements, and the BIOS for Intel® NUC Board NUC7i3BNB.

Intended Audience

The TPS is intended to provide detailed, technical information about Intel® NUC Board NUC7i3BNB and its components to the vendors, system integrators, and other engineers and technicians who need this level of information. It is specifically *not* intended for general audiences.

What This Document Contains

Chapter	Description
1	A description of the hardware used on Intel NUC Board NUC7i3BNB
2	A map of the resources of the Intel NUC Board
3	The features supported by the BIOS Setup program
4	A description of the BIOS error messages, beep codes, and POST codes
5	The features of the Intel NUC kit NUC7i3BNK and NUC7i3BNH

Typographical Conventions

This section contains information about the conventions used in this specification. Not all of these symbols and abbreviations appear in all specifications of this type.

Notes, Cautions, and Warnings



NOTE

Notes call attention to important information.



CAUTION

Cautions are included to help you avoid damaging hardware or losing data.

Other Common Notation

#	Used after a signal name to identify an active-low signal (such as USBP0#)
GB	Gigabyte (1,073,741,824 bytes)
GB/s	Gigabytes per second
Gb/s	Gigabits per second
KB	Kilobyte (1024 bytes)
Kb	Kilobit (1024 bits)
kb/s	1000 bits per second
MB	Megabyte (1,048,576 bytes)
MB/s	Megabytes per second
Mb	Megabit (1,048,576 bits)
Mb/s	Megabits per second
TDP	Thermal Design Power
Xxh	An address or data value ending with a lowercase h indicates a hexadecimal value.
x.x V	Volts. Voltages are DC unless otherwise specified.
*	This symbol is used to indicate third-party brands and names that are the property of their respective owners.

Contents

Revision History	ii
Disclaimer	ii
Board Identification Information.....	iv
Product Identification Information.....	iv
Errata.....	v
Preface	vi
Intended Audience.....	vi
What This Document Contains	vi
Typographical Conventions	vi
Contents	ix
1 Product Description	15
1.1 Overview	15
1.1.1 Feature Summary	15
1.1.2 Board Layout (Top)	17
1.1.3 Board Layout (Bottom).....	19
1.1.4 Block Diagram	21
1.2 Online Support.....	22
1.3 Processor	22
1.4 System Memory	23
1.5 Processor Graphics Subsystem.....	25
1.5.1 Integrated Graphics	25
1.6 USB.....	28
1.7 SATA Interface.....	28
1.7.1 AHCI Mode.....	29
1.7.2 Intel® Rapid Storage Technology / SATA RAID	29
1.7.3 Intel® Next Generation Storage Acceleration.....	29
1.8 Real-Time Clock Subsystem.....	30
1.9 Audio Subsystem	30
1.9.1 Audio Subsystem Software	31
1.10 LAN Subsystem.....	31
1.10.1 Intel® I219V Gigabit Ethernet Controller	31
1.10.2 LAN Subsystem Software.....	31
1.10.3 RJ-45 LAN Connector with Integrated LEDs.....	32
1.10.4 Wireless Network Module.....	33
1.11 Hardware Management Subsystem	33
1.11.1 Hardware Monitoring	33
1.11.2 Fan Monitoring.....	33

1.11.3	Thermal Solution	33
1.12	Power Management	35
1.12.1	ACPI	35
1.12.2	Hardware Support	38
1.13	Intel Platform Security Technologies	40
1.13.1	Intel® Virtualization Technology	40
1.13.2	Intel® Platform Trust Technology	40
2	Technical Reference	41
2.1	Memory Resources	41
2.1.1	Addressable Memory	41
2.2	Connectors and Headers	41
2.2.1	Front Panel Connectors	42
2.2.2	Back Panel Connectors	42
2.2.3	Headers and Connectors (Top)	43
2.2.4	Connectors and Headers (Bottom)	44
2.3	BIOS Security Jumper	55
2.4	Mechanical Considerations	57
2.4.1	Form Factor	57
2.5	Electrical Considerations	58
2.5.1	Power Supply Considerations	58
2.5.2	Fan Header Current Capability	58
2.6	Thermal Considerations	59
2.7	Reliability	64
2.8	Environmental	64
3	Overview of BIOS Features	65
3.1	Introduction	65
3.2	BIOS Flash Memory Organization	66
3.3	System Management BIOS (SMBIOS)	66
3.4	Legacy USB Support	66
3.5	BIOS Updates	67
3.5.1	Language Support	67
3.6	BIOS Recovery	67
3.7	Boot Options	69
3.7.1	Network Boot	69
3.7.2	Booting Without Attached Devices	69
3.7.3	Changing the Default Boot Device During POST	69
3.7.4	Power Button Menu	70
3.8	Hard Disk Drive Password Security Feature	71
3.9	BIOS Security Features	72
4	Error Messages and Blink Codes	73
4.1	Front-panel Power LED Blink Codes	73
4.2	BIOS Error Messages	73

5 Intel NUC Kit Features	74
5.1 Chassis Front Panel Features	74
5.3 Chassis Rear Panel Features.....	76

Figures

Figure 1. Major Board Components (Top)	17
Figure 2. Major Board Components (Bottom)	19
Figure 3. Block Diagram.....	21
Figure 4. Memory Channel and SO-DIMM Configuration.....	24
Figure 5. 4-Pin 3.5 mm (1/8 inch) Audio Jack Pin Out	30
Figure 6. LAN Connector LED Locations.....	32
Figure 7. Thermal Solution and Fan Header.....	34
Figure 8. Location of the Standby Power LED	39
Figure 9. Front Panel Connectors.....	42
Figure 10. Back Panel Connectors	42
Figure 11. Headers and Connectors (Top).....	43
Figure 12. Connectors and Headers (Bottom)	44
Figure 13. Connection Diagram for Front Panel Header (2.0 mm Pitch)	49
Figure 14. Connection Diagram for the Internal USB 2.0 Single-Port Header (1.25 mm Pitch)	53
Figure 15. Location of the CIR Sensor	53
Figure 16. Location of the BIOS Security Jumper	55
Figure 17. Board Dimensions.....	57
Figure 18. Board Height Dimensions	58
Figure 19. Localized High Temperature Zones	60
Figure 20. Installation Area of Thermal Pad for Intel NUC Kit NUC7i3BNK	61
Figure 21. Installation area of Thermal Pad for Intel NUC Kit NUC7i3BNH.....	62
Figure 22. Intel NUC Kit NUC7i3BNH Features – Front	74
Figure 23. Intel NUC Kit NUC7i3BNK Features – Front.....	75
Figure 24. Intel NUC Kit NUC7i3BNH Features – Rear	76
Figure 25. Intel NUC Kit NUC7i3BNK Features – Rear	77

Tables

Table 1. Feature Summary	15
Table 2. Components Shown in Figure 1	18
Table 3. Components Shown in Figure 2.....	20
Table 4. Supported Memory Configurations.....	23
Table 5. Unsupported Memory Configurations.....	23
Table 6. DisplayPort Multi-Streaming Resolutions.....	26
Table 7. Multiple Display Configuration Maximum Resolutions	27
Table 8. Audio Formats Supported by the HDMI* and USB Type-C Interfaces.....	27
Table 9. LAN Connector LED States.....	32
Table 10. Effects of Pressing the Power Switch.....	35
Table 11. Power States and Targeted System Power.....	36
Table 12. Wake-up Devices and Events	37
Table 13. Headers and Connectors Shown in Figure 11	43
Table 14. Connectors and Headers Shown in Figure 12	45
Table 15. SATA Power Connector (1.25 mm pitch).....	46

Table 16. Single-Port Internal USB 2.0 Header (1.25 mm pitch)	46
Table 17. M.2 2280 Module (key type M) Connector.....	46
Table 18. Digital Microphone (DMICS) Array Connector (1.25 mm Pitch).....	47
Table 19. Front Panel HDD LED Ring Connector (1.25 mm Pitch)	48
Table 20. CEC Header (1.25 mm pitch).....	48
Table 21. Front Panel Header (2.0 mm Pitch).....	49
Table 22. States for a One-Color Power LED	50
Table 23. States for a Dual-Color Power LED	50
Table 24. SDXC Card Reader Connector	51
Table 25. HDMI CEC expected behavior.....	54
Table 26. Front Panel LED Ring	54
Table 27. BIOS Security Jumper Settings.....	56
Table 28. Fan Header Current Capability.....	58
Table 29. Thermal Considerations for Components.....	63
Table 30. Tcontrol Values for Components	63
Table 31. Environmental Specifications.....	64
Table 32. Acceptable Drives/Media Types for BIOS Recovery	67
Table 33. Boot Device Menu Options.....	69
Table 34. Master Key and User Hard Drive Password Functions.....	71
Table 35. Supervisor and User Password Functions.....	72
Table 36. Front-panel Power LED Blink Codes	73
Table 37. Components Shown in Figure 22	74
Table 38. Components Shown in Figure 23	75
Table 39. Components Shown in Figure 24	76
Table 40. Components Shown in Figure 25	77

1 Product Description

1.1 Overview

1.1.1 Feature Summary

Table 1 summarizes the major features of Intel® NUC Board NUC7i3BNB.

Table 1. Feature Summary

Form Factor	4.0 inches by 4.0 inches (101.60 millimeters by 101.60 millimeters)
Processor	<ul style="list-style-type: none">• A soldered-down 7th generation Intel® Core™ i3-7100U dual-core processor with up to a maximum 15 W TDP (if thermal margin available)<ul style="list-style-type: none">— Intel® HD Graphics 620— Integrated memory controller— Integrated PCH
Memory	<ul style="list-style-type: none">• Two 260-pin 1.2 V DDR4 SDRAM Small Outline Dual Inline Memory Module (SO-DIMM) sockets• Support for DDR4 1866/2133 MHz SO-DIMMs• Support for 4 Gb and 8 Gb memory technology• Support for up to 32 GB of system memory with two SO-DIMMs using 8 Gb memory technology• Support for non-ECC memory• Support for 1.2 V low voltage JEDEC memory only Note: 2 Gb memory technology (SDRAM Density) is not supported
Graphics	<ul style="list-style-type: none">• Integrated graphics support for processors with Intel® Graphics Technology:<ul style="list-style-type: none">— One High Definition Multimedia Interface* (HDMI*) back panel connector— One USB Type-C back panel connector
Audio	<ul style="list-style-type: none">• Intel® High Definition (Intel® HD) Audio via the HDMI v2.0a and USB Type-C interfaces through the processor• Realtek HD Audio via a stereo microphone/headphone 3.5 mm jack on the front panel• Digital microphone array (DMICS) connector (internal)
Storage	<ul style="list-style-type: none">• SATA ports:<ul style="list-style-type: none">— One SATA 6.0 Gb/s port (black) for 2.5" storage device• One SATA 6.0 Gb/s port is reserved for an M.2 storage module supporting M.2 2242 and M.2 2280 (key type M and B+M) modules Note: Supports key type M (PCI Express* x1/x2/x4 and SATA)

continued

Table 1. Feature Summary (continued)

Peripheral Interfaces	<ul style="list-style-type: none">• One USB 3.1 (Gen 2) port implemented via the external back panel USB Type-C connector• USB 3.0 ports:<ul style="list-style-type: none">• Two ports are implemented with external front panel connectors (one blue and one orange charging capable)• Two ports are implemented with external back panel connectors (blue)• USB 2.0 ports:<ul style="list-style-type: none">• Two ports via two single-port internal 1x4 1.25 mm pitch headers (white)• One port is reserved for the M.2 2230 Wireless module• Consumer Infrared (CIR)
Expansion Capabilities	<ul style="list-style-type: none">• One M.2 connector supporting M.2 2242 and M.2 2280 (key type M and B+M) modules• One Micro SDXC slot <p>Note: The Micro SDXC card reader is not supported in Microsoft* Windows* 7</p>
BIOS	<ul style="list-style-type: none">• Intel® BIOS resident in the Serial Peripheral Interface (SPI) Flash device• Support for Advanced Configuration and Power Interface (ACPI), Plug and Play, and System Management BIOS (SMBIOS)
Instantly Available PC Technology	<ul style="list-style-type: none">• Suspend to RAM support• Wake on PCI Express, LAN, front panel, CIR, and USB ports
LAN	Gigabit (10/100/1000 Mb/s) LAN subsystem using the Intel® I219V Gigabit Ethernet Controller
Hardware Monitor Subsystem	Hardware monitoring subsystem, based on a ITE Tech. IT8987E-VG embedded controller, including: <ul style="list-style-type: none">• Voltage sense to detect out of range power supply voltages• Thermal sense to detect out of range thermal values• One processor fan header• Fan sense input used to monitor fan activity• Fan speed control
Wireless	Intel® Dual Band Wireless-AC 8265 <ul style="list-style-type: none">• 802.11ac, Dual Band, 2x2 Wi-Fi + Bluetooth 4.2• Maximum Transfer speed up to 867Mbps• Supports Intel® Smart Connect Technology

1.1.2 Board Layout (Top)

Figure 1 shows the location of the major components on the top-side of Intel NUC Board NUC7i3BNB.

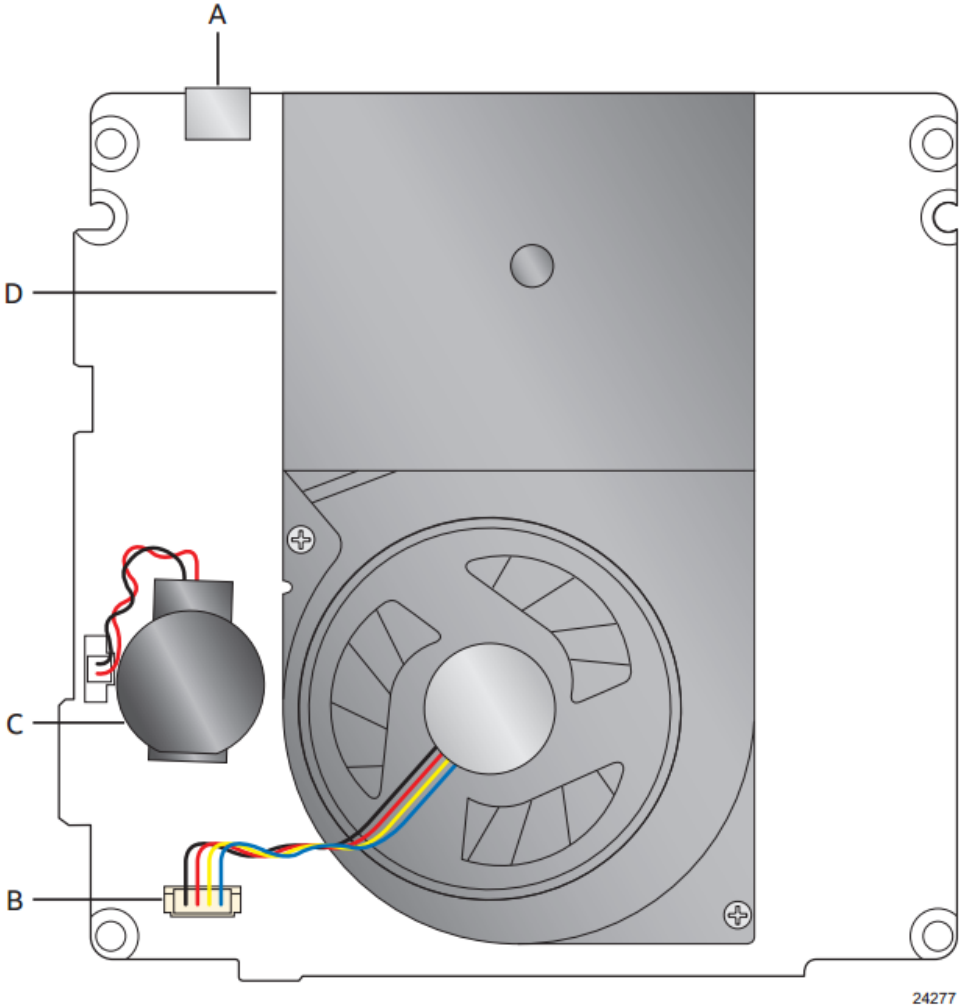

Figure 1. Major Board Components (Top)

Table 2 lists the components identified in Figure 1.

Table 2. Components Shown in Figure 1

Item from Figure 1	Description
A	USB Type-C connector
B	Processor fan header
C	Battery
D	Thermal solution

1.1.3 Board Layout (Bottom)

Figure 2 shows the location of the major components on the bottom-side of Intel NUC Board NUC7i3BNB.

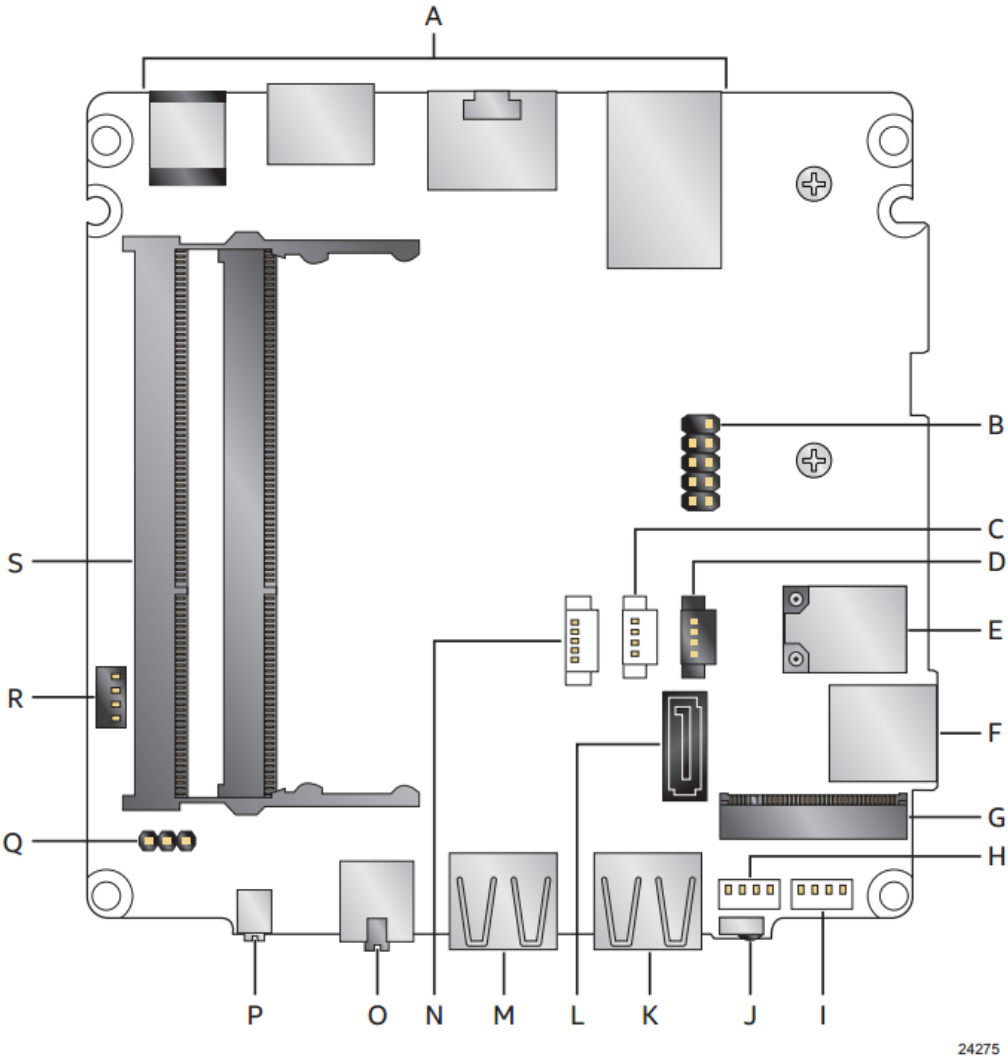

24275

Figure 2. Major Board Components (Bottom)

Table 3. Components Shown in Figure 2

Item from Figure 2	Description
A	Back panel connectors
B	Front panel header
C	Digital microphone array connector
D	Front panel LED ring connector
E	Intel Dual Band Wireless AC + Bluetooth 8265 module
F	Micro SDXC slot
G	M.2 connector (key type M and B+M) for 2242 and 2280 modules
H	Front panel single-port USB 2.0 header (1.25 mm pitch)
I	Front panel single-port USB 2.0 header (1.25 mm pitch)
J	Consumer Infrared (CIR) sensor
K	Front panel USB 3.0 connector (blue)
L	SATA 6.0 Gb/s connector
M	Front panel USB 3.0 connector (orange, charging)
N	SATA power connector (1.25 mm pitch)
O	Front panel stereo microphone/headphone jack
P	Front panel power button
Q	BIOS security jumper
R	Consumer electronics control (CEC) header
S	DDR4 SO-DIMM sockets

1.1.4 Block Diagram

Figure 3 is a block diagram of the major functional areas of the board.

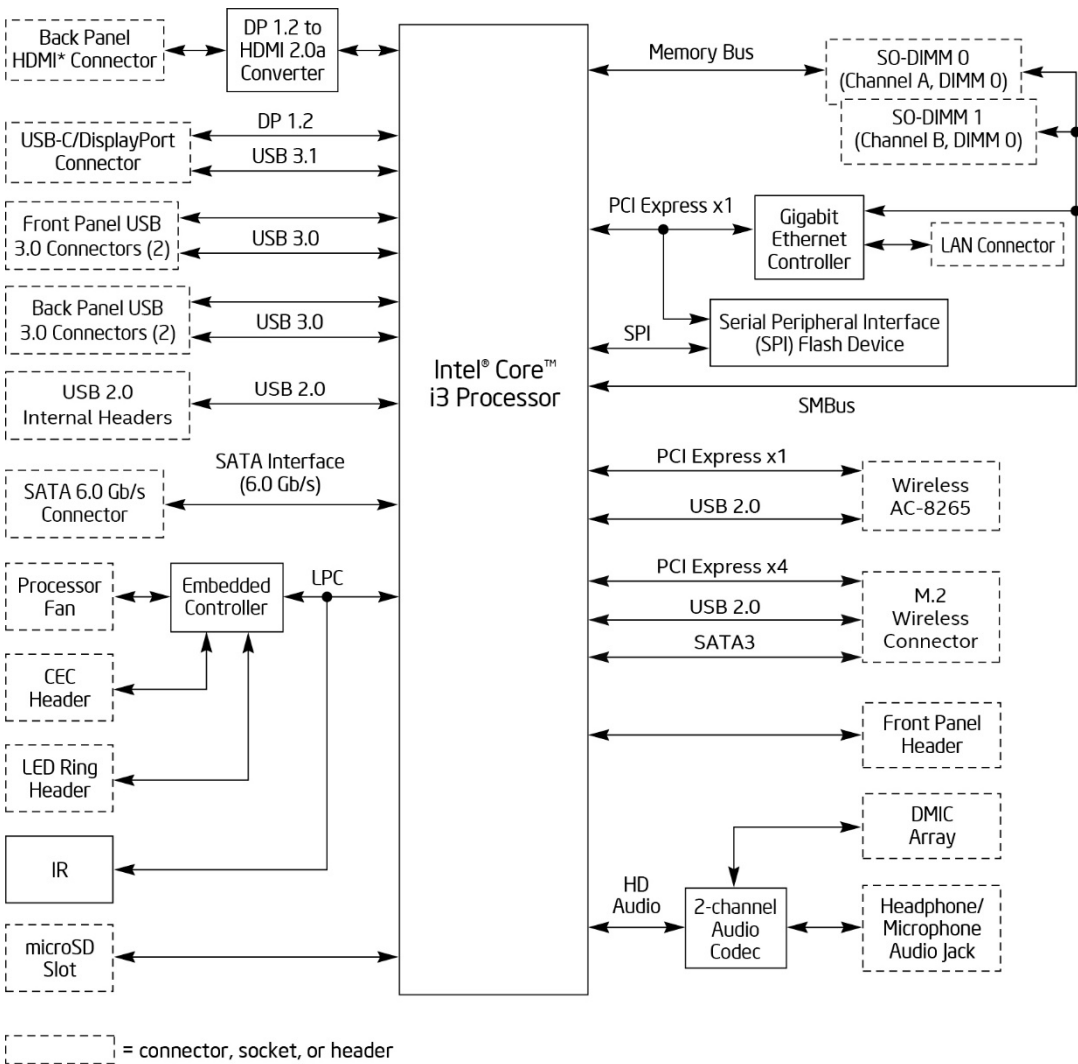

24290B

Figure 3. Block Diagram

1.2 Online Support

To find information about...

Intel NUC Board NUC7i3BNB
Intel NUC Support
Available configurations for Intel NUC Board NUC7i3BNB
Product support page NUC7i3BNK
Product support page NUC7i3BNH
BIOS and driver updates
BIOS and driver updates for NUC7i3BNK
BIOS and driver updates for NUC7i3BNH
Tested memory
Integration information
Processor datasheet

Visit this World Wide Web site:

<http://www.intel.com/NUC>
<http://www.intel.com/NUCSupport>
<http://ark.intel.com>
<http://www.intel.com/content/www/us/en/support/boards-and-kits/intel-nuc-kits/intel-nuc-kit-nuc7i3bnk.html>
<http://www.intel.com/content/www/us/en/support/boards-and-kits/intel-nuc-kits/intel-nuc-kit-nuc7i3bnh.html>
<http://downloadcenter.intel.com>
<https://downloadcenter.intel.com/product/95069>
<https://downloadcenter.intel.com/product/95066>
<http://www.intel.com/content/www/us/en/support/boards-and-kits/000020648.html>
<http://www.intel.com/NUCSupport>
<http://ark.intel.com>

1.3 Processor

A soldered-down 7th generation Intel® Core™ i3-7100U dual-core processor with up to a maximum 15 W TDP (if thermal margin is available).

- Intel® HD Graphics 620
- Integrated memory controller
- Integrated PCH



NOTE

There are specific requirements for providing power to the processor. Refer to Section 2.5.1 on page 58 for information on power supply requirements.

1.4 System Memory

The board has two 260-pin SO-DIMM sockets and supports the following memory features:

- 1.2 V DDR4 SDRAM SO-DIMMs with gold plated contacts
- Two independent memory channels with interleaved mode support
- Unbuffered, single-sided or double-sided SO-DIMMs
- 32 GB maximum total system memory (with 8 Gb memory technology). Refer to Section 2.1.1 on page 41 for information on the total amount of addressable memory.
- Minimum recommended total system memory: 2048 MB
- Non-ECC SO-DIMMs
- Serial Presence Detect
- DDR4 1866/2133 MHz SDRAM SO-DIMMs



NOTE

To be fully compliant with all applicable DDR SDRAM memory specifications, the board should be populated with SO-DIMMs that support the Serial Presence Detect (SPD) data structure. This allows the BIOS to read the SPD data and program the chipset to accurately configure memory settings for optimum performance. If non-SPD memory is installed, the BIOS will attempt to correctly configure the memory settings, but performance and reliability may be impacted or the SO-DIMMs may not function under the determined frequency.



NOTE

Intel NUC Board NUC7i3BNB supports only 4 Gb and 8 Gb memory technologies (also referred to as “SDRAM density”). Table 4 lists the supported SO-DIMM configurations. Table 5 lists the SO-DIMM configurations that are **not** supported.

Table 4. Supported Memory Configurations

SO-DIMM Capacity	Configuration ^(Note)	SDRAM Density	SDRAM Organization Front-side/Back-side	Number of SDRAM Devices
2048 MB	SS	4 Gbit	512 M x4/empty	4
4096 MB	DS	4 Gbit	512 M x4/512 M x4	8
4096 MB	SS	8 Gbit	1024 M x4/empty	4
8192 MB	DS	4 Gbit	512 M x8/512 M x8	16
8192 MB	DS	8 Gbit	1024 M x4/1024 M x4	8
16384 MB	DS	8 Gbit	1024 M X8/1024 M x8	16

Note: “DS” refers to double-sided memory modules and “SS” refers to single-sided memory modules.

Table 5. Unsupported Memory Configurations

SO-DIMM Capacity	Configuration ^(Note)	SDRAM Density	SDRAM Organization Front-side/Back-side	Number of SDRAM Devices
1024 MB	SS	1 Gbit	128 M x8/empty	8
2048 MB	DS	1 Gbit	128 M x8/128 M x8	16
2048 MB	SS	2 Gbit	256 M x8/empty	8
4096 MB	DS	2 Gbit	256 M x8/256 M x8	16

Note: “DS” refers to double-sided memory modules and “SS” refers to single-sided memory modules.

For information about...

Refer to:

Tested Memory

<http://www.intel.com/content/www/us/en/support/boards-and-kits/000020648.html>

Figure 4 illustrates the memory channel and SO-DIMM configuration.

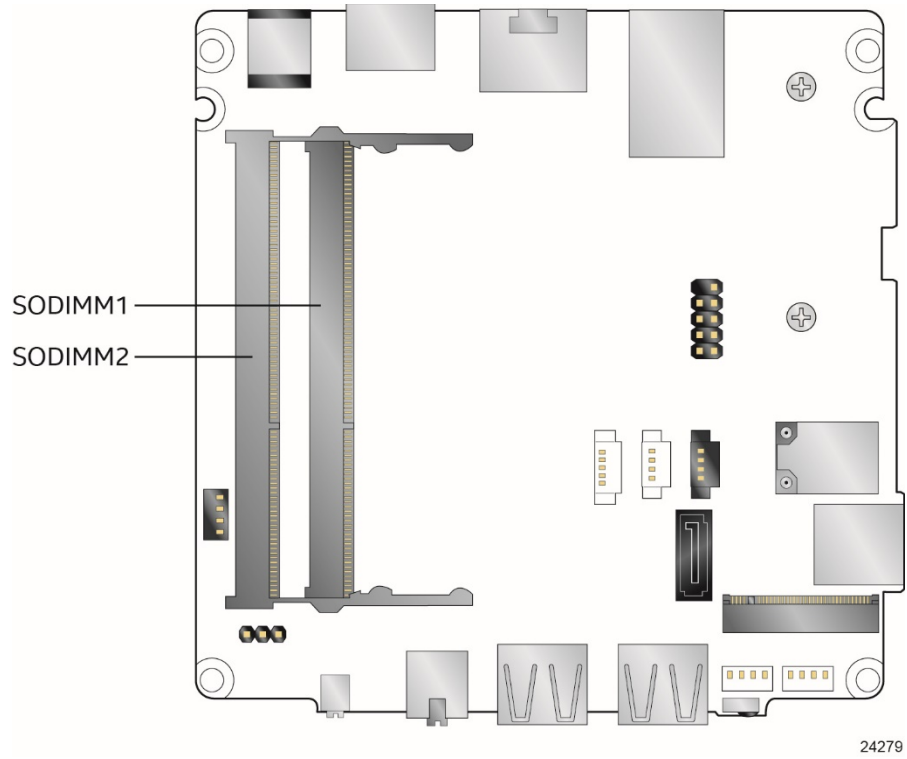

Figure 4. Memory Channel and SO-DIMM Configuration

1.5 Processor Graphics Subsystem

The board supports graphics through Intel HD Graphics.

1.5.1 Integrated Graphics

The board supports integrated graphics via the processor.

1.5.1.1 Intel® High Definition (Intel® HD) Graphics

The Intel HD graphics controller features the following:

- 3D Features
 - DirectX* 12.1 support
 - OpenGL* 5.0 support
 - OpenCL* 2.1 support
- Next Generation Intel® Clear Video Technology HD support is a collection of video playback and enhancement features that improve the end user's viewing experience
- Encode/transcode HD content
- Playback of high definition content including Blu-ray* disc
- Superior image quality with sharper, more colorful images
- DirectX* Video Acceleration (DXVA) support for accelerating video processing
- Full AVC/VC1/MPEG2/HEVC HW Encode/Decode
- Intel HD Graphics with Advanced Hardware Video Transcoding (Intel® Quick Sync Video)



NOTE

Intel Quick Sync Video is enabled by an appropriate software application.

1.5.1.2 Video Memory Allocation

Intel® Dynamic Video Memory Technology (DVMT) is a method for dynamically allocating system memory for use as graphics memory to balance 2D/3D graphics and system performance. If your computer is configured to use DVMT, graphics memory is allocated based on system requirements and application demands (up to the configured maximum amount). When memory is no longer needed by an application, the dynamically allocated portion of memory is returned to the operating system for other uses.

1.5.1.3 High Definition Multimedia Interface* (HDMI*)

The HDMI port supports standard, enhanced, or high definition video, plus multi-channel digital audio on a single cable. The port is compatible with all ATSC and DVB HDTV standards and supports eight full range channels at 24-bit/96 kHz audio of lossless audio formats. The maximum supported resolution is 4096 x 2160 @ 60 Hz, 24bpp. The HDMI port is compliant with the HDMI 2.0A specification.

For information about

HDMI technology

Refer to

<http://www.hdmi.org>

1.5.1.4 DisplayPort* via USB Type-C

DisplayPort is a digital communication interface that utilizes differential signaling to achieve a high bandwidth bus interface designed to support connections between PCs and monitors, projectors, and TV displays. DisplayPort is suitable for display connections between consumer electronics devices such as high definition optical disc players, set top boxes, and TV displays. The maximum supported resolution is 4096 x 2304 @ 60 Hz, 24bpp. DisplayPort via USB Type-C connector is compliant with the DisplayPort 1.2 specification.

DisplayPort output supports Multi-Stream Transport (MST) which allows for multiple independent video streams (daisy-chain connection with multiple monitors) over a single DisplayPort. This will require the use of displays that support DisplayPort 1.2 and allow for this feature.

For information about

DisplayPort technology

Refer to

<http://www.displayport.org>

1.5.1.4.1 DisplayPort 1.2 Multi-Stream Transport Daisy-Chaining

Table 6 lists the maximum resolutions available when using DisplayPort 1.2 Multi-Stream Transport.

Table 6. DisplayPort Multi-Streaming Resolutions

DisplayPort Usage Models	Monitor 1	Monitor 2	Monitor 3
3 Monitors	1920 x 1200 @ 60 Hz	1920 x 1080 @ 60 Hz	1920 x 1080 @ 60 Hz
2 Monitors	2560 x 1600 @ 60 Hz	2560 x 1600 @ 60 Hz	
3 Monitors (with DisplayPort 1.2 hub)	1920 x 1080 @ 60 Hz	1920 x 1080 @ 60 Hz	1920 x 1080 @ 60 Hz

1.5.1.5 Multiple DisplayPort and HDMI Configurations

Multiple DisplayPort and HDMI configurations feature the following:

- Two independent displays with 4K support
 - HDMI and USB Type-C
- Single HDMI 2.0A with 4K support
- Single DisplayPort 1.2 with 4K support via USB Type-C connector
- Collage Display

Table 7. Multiple Display Configuration Maximum Resolutions

Single Display HDMI	Dual Display USB Type-C and HDMI	Single Display DisplayPort via USB Type-C
4096 x 2160 @ 60 Hz	4096 x 2304 @ 60 Hz (USB Type-C) 4096 x 2160 @ 60 Hz (HDMI)	4096 x 2304 @ 60 Hz

Note: Higher resolutions may be achievable but only at lower refresh rates

For information about	Refer to
Multiple display maximum resolutions	https://www-ssl.intel.com/content/www/us/en/processors/core/CoreTechnicalResources.html (Generic link)

1.5.1.6 High-bandwidth Digital Content Protection (HDCP)

HDCP is the technology for protecting high definition content against unauthorized copy or interception between a source (computer, digital set top boxes, etc.) and the sink (panels, monitor, and TVs). The PCH supports HDCP 2.2 for content protection over wired displays (USB Type-C and HDMI).

1.5.1.7 Integrated Audio Provided by the HDMI and USB Type-C Interfaces

The HDMI and USB Type-C interfaces from the PCH support audio. The processor supports two High Definition audio streams on two digital ports simultaneously.

Table 8 shows the specific audio technologies supported by the PCH.

Table 8. Audio Formats Supported by the HDMI and USB Type-C Interfaces

Audio Formats	HDMI	USB Type-C
AC3 – Dolby* Digital	Yes	Yes
Dolby Digital Plus	Yes	Yes
DTS-HD*	Yes	Yes
LPCM, 176.4kHz/24 bit, 8 channel	Yes	Yes
Dolby True HD, DTS-HD Master Audio* (Lossless Blu-ray Disc Audio Format)	Yes	Yes

1.6 USB

The USB port arrangement is as follows:

- USB 3.1 Gen 2 Type-C port implemented via the external back panel USB Type-C connector (maximum current is 3A):
- USB 3.0 ports (maximum current is 900 mA for each blue port, 1.5 A for the orange charging port):
 - Two ports are implemented with external front panel connectors (one blue and one orange charging capable)
 - Two ports are implemented with external back panel connectors (blue)
- USB 2.0 ports (maximum current is 500 mA for each port of the white header (1 A total):
 - Two ports via two single-port internal 1x4 1.25 mm pitch headers (white)
 - One port is reserved for the M.2 2230 Wireless module

All the USB ports are high-speed, full-speed, and low-speed capable.



NOTE

Computer systems that have an unshielded cable attached to a USB port may not meet FCC Class B requirements, even if no device is attached to the cable. Use a shielded cable that meets the requirements for full-speed devices.

For information about	Refer to
The location of the USB connectors on the back panel	Figure 9, page 42
The location of the front panel USB headers	Figure 2, page 19

1.7 SATA Interface

The board provides the following SATA interfaces:

- SATA ports:
 - One SATA 6.0 Gb/s port for 2.5" storage device
- One SATA 6.0 Gb/s port is reserved for an M.2 storage module supporting M.2 2242 and M.2 2280 (key type M and B+M) modules

The PCH provides independent SATA ports with a theoretical maximum transfer rate of 6 Gb/s. A point-to-point interface is used for host to device connections.

1.7.1 AHCI Mode

The board supports AHCI storage mode.



NOTE

In order to use AHCI mode, AHCI must be enabled in the BIOS. Microsoft Windows* 10 includes the necessary AHCI drivers without the need to install separate AHCI drivers during the operating system installation process; however, it is always good practice to update the AHCI drivers to the latest available by Intel.*

1.7.2 Intel® Rapid Storage Technology / SATA RAID

The PCH supports Intel® Rapid Storage Technology, providing both AHCI and integrated RAID functionality. The RAID capability provides high-performance RAID 0 and 1 functionality on all SATA ports. Other RAID features include hot spare support and SMART alerting. Software components include an Option ROM for pre-boot configuration and boot functionality, a Microsoft Windows compatible driver, and a user interface for configuration and management of the RAID capability of the PCH.



NOTE

Intel Rapid Storage Technology / SATA RAID is only supported if an M.2 SATA SSD module is used with the onboard SATA interface. RAID is not available when using M.2 PCIe SSD module and onboard SATA interface.

1.7.3 Intel® Next Generation Storage Acceleration

Intel® Next Generation Storage Acceleration with Intel® Optane™ Technology is a disk caching solution that can provide improved computer system performance with improved power savings. It allows configuration of a computer system with the advantage of having HDDs for maximum storage capacity and with Intel® Optane™ Technology for improved system performance.

For more information on Intel® Optane™ Technology, go to

<http://www.intel.com/content/www/us/en/architecture-and-technology/non-volatile-memory.html>



NOTE

In order to use supported RAID and Intel Next Generation Storage Acceleration with Intel® Optane™ Technology features, you must first enable RAID in the BIOS.

1.8 Real-Time Clock Subsystem

A coin-cell battery (CR2032) powers the real-time clock and CMOS memory. When the computer is not plugged into a wall socket, the battery has an estimated life of three years. When the computer is plugged in, the standby current from the power supply extends the life of the battery. The clock is accurate to ± 13 minutes/year at 25 °C with 3.3 VSB applied via the power supply 5 V STBY rail.



NOTE

If the battery and AC power fail, date and time values will be reset and the user will be notified during the POST.

When the voltage drops below a certain level, the BIOS Setup program settings stored in CMOS RAM (for example, the date and time) might not be accurate. Replace the battery with an equivalent one. Figure 1 on page 17 shows the location of the battery.

1.9 Audio Subsystem

The audio subsystem supports the following features:

- Digital microphone array (DMICS) connectors (internal)
- Analog line-out/Analog Headphone/Analog Microphone (front panel jack)
- Support for 44.1 kHz/48 kHz/96 kHz/192 kHz sample rates on all analog outputs
- Support for 44.1 kHz/48 kHz/96 kHz sample rates on all analog inputs
- Front Panel Audio Jack Support (see Figure 5 for 3.5 mm audio jack pin out):
 - Speakers only (Stereo)
 - Headphones only (Stereo)
 - Microphone only (mono)
 - Combo Headphone (Stereo)/Microphone (mono)



Pin Number	Pin Name	Description
1	Tip	Left Audio Out
2	Ring	Right Audio Out
3	Ring	Common/Ground
4	Sleeve	Audio In/MIC

Figure 5. 4-Pin 3.5 mm (1/8 inch) Audio Jack Pin Out



NOTE

The analog circuit of the front panel audio connector is designed to power headphones or amplified speakers only. Poor audio quality occurs if passive (nonamplified) speakers are connected to this output.

1.9.1 Audio Subsystem Software

Audio software and drivers are available from Intel's World Wide Web site.

For information about	Refer to
Obtaining Audio software and drivers	http://downloadcenter.intel.com

1.10 LAN Subsystem

The LAN subsystem consists of the following:

- Intel I219V Gigabit Ethernet Controller (10/100/1000 Mb/s)
- RJ-45 LAN connector with integrated status LEDs

Additional features of the LAN subsystem include:

- CSMA/CD protocol engine
- LAN connect interface between the Processor and the LAN controller
- Power management capabilities
 - ACPI technology support
 - LAN wake capabilities
- LAN subsystem software

1.10.1 Intel® I219V Gigabit Ethernet Controller

The Intel I219V Gigabit Ethernet Controller supports the following features:

- Compliant with the 1 Gb/s Ethernet 802.3, 802.3u, 802.3z, 802.3ab specifications
- Multi-speed operation: 10/100/1000 Mb/s
- Full-duplex operation at 10/100/1000 Mb/s; Half-duplex operation at 10/100 Mb/s
- Flow control support compliant with the 802.3X specification as well as the specific operation of asymmetrical flow control defined by 802.3z
- VLAN support compliant with the 802.3q specification
- Supports Jumbo Frames (up to 9 kB)
 - IEEE 1588 supports (Precision Time Protocol)
- MAC address filters: perfect match unicast filters, multicast hash filtering, broadcast filter, and promiscuous mode

1.10.2 LAN Subsystem Software

LAN software and drivers are available from Intel's World Wide Web site.

For information about	Refer to
Obtaining LAN software and drivers	http://downloadcenter.intel.com

1.10.3 RJ-45 LAN Connector with Integrated LEDs

Two LEDs are built into the RJ-45 LAN connector (shown in Figure 6).

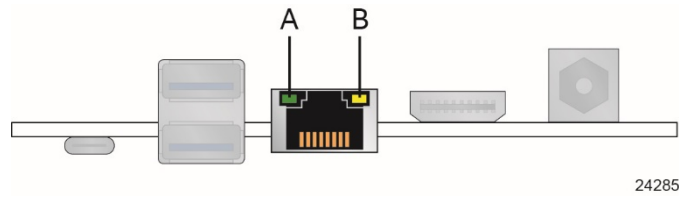

Item	Description
A	Link LED (Green)
B	Data Rate LED (Green/Yellow)

Figure 6. LAN Connector LED Locations

Table 9 describes the LED states when the board is powered up and the LAN subsystem is operating.

Table 9. LAN Connector LED States

LED	LED Color	LED State	Condition
Link	Green	Off	LAN link is not established.
		On	LAN link is established.
		Blinking	LAN activity is occurring.
Data Rate	Green/Yellow	Off	10 Mb/s data rate is selected.
		Green	100 Mb/s data rate is selected.
		Yellow	1000 Mb/s data rate is selected.

1.10.4 Wireless Network Module

The Intel Dual Band Wireless-AC 8265 module provides hi-speed wireless connectivity provided with the following capabilities:

- Compliant IEEE 802.11abgn, 802.11ac, 802.11d, 802.11e, 802.11i, 802.11h, 802.11w specifications
- Maximum bandwidth of 867 Mbps
- Dual Mode Bluetooth* 4.2
- OS certified with Microsoft Windows 10
- Wi-Fi Direct* for peer to peer device connections
- Wi-Fi Miracast Source
- Authentication: WPA and WPA2, 802.1X (EAP-TLS, TTLS, PEAP, LEAP, EAP-FAST), EAP-SIM, EAP-AKA
- Encryption: 64-bit and 128-bit WEP, AES-CCMP, TKIP, WPA2, AES-CCMP

For information about	Refer to
Obtaining WLAN software and drivers	http://downloadcenter.intel.com
Full Specifications	http://intel.com/wireless

1.11 Hardware Management Subsystem

The hardware management features enable the board to be compatible with the Wired for Management (WfM) specification. The board has several hardware management features, including thermal and voltage monitoring.

For information about	Refer to
Wired for Management (WfM) Specification	www.intel.com/design/archives/wfm/

1.11.1 Hardware Monitoring

The hardware monitoring and fan control subsystem is based on an ITE Tech. IT8987E-VG embedded controller, which supports the following:

- Processor and system ambient temperature monitoring
- Chassis fan speed monitoring
- Voltage monitoring of CPU IO Vcc (+Vccio), Memory Vcc (V_SM), CPU IN Vcc (+Vccp)
- SMBus interface

1.11.2 Fan Monitoring

Fan monitoring can be implemented using third-party software.

1.11.3 Thermal Solution

Figure 7 shows the location of the thermal solution and processor fan header.

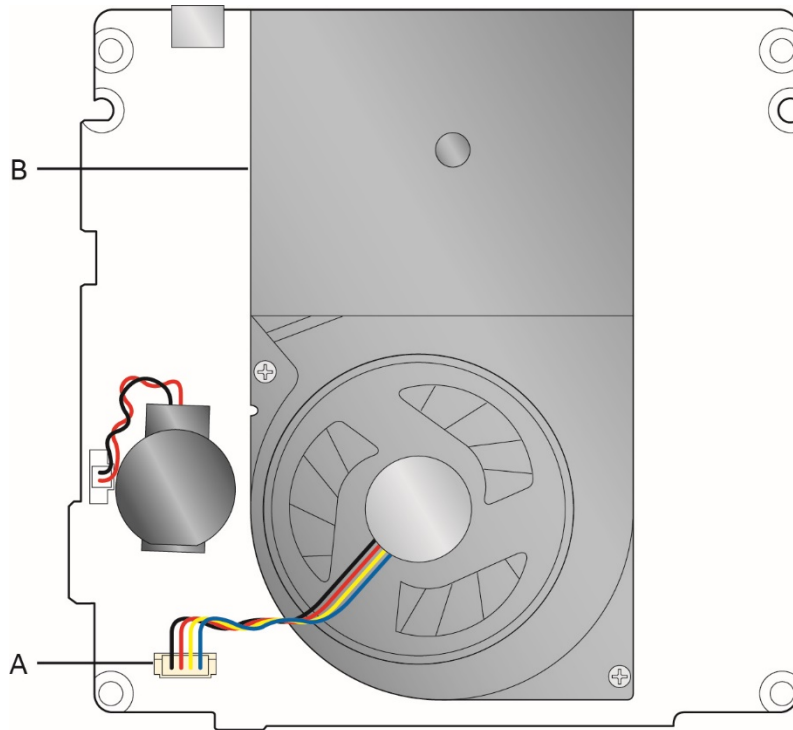

24287

Item	Description
A	Processor fan header
B	Thermal solution

Figure 7. Thermal Solution and Fan Header

1.12 Power Management

Power management is implemented at several levels, including:

- Software support through Advanced Configuration and Power Interface (ACPI)
- Hardware support:
 - Power Input
 - Instantly Available PC technology
 - LAN wake capabilities
 - Wake from USB
 - WAKE# signal wake-up support
 - Wake from S5
 - Wake from CIR
 - +5 V Standby Power Indicator LED

1.12.1 ACPI

ACPI gives the operating system direct control over the power management and Plug and Play functions of a computer. The use of ACPI with this board requires an operating system that provides full ACPI support. ACPI features include:

- Plug and Play (including bus and device enumeration)
- Power management control of individual devices, add-in boards (some add-in boards may require an ACPI-aware driver), video displays, and hard disk drives
- Methods for achieving less than 15-watt system operation in the power-on/standby sleeping state
- A Soft-off feature that enables the operating system to power-off the computer
- Support for multiple wake-up events (see Table 12 on page 37)
- Support for a front panel power and sleep mode switch

Table 10 lists the system states based on how long the power switch is pressed, depending on how ACPI is configured with an ACPI-aware operating system.

Table 10. Effects of Pressing the Power Switch

If the system is in this state...	...and the power switch is pressed for	...the system enters this state
Off (ACPI G2/G5 – Soft off)	Less than four seconds	Power-on (ACPI G0 – working state)
On (ACPI G0 – working state)	Less than four seconds	Soft-off/Standby (ACPI G1 – sleeping state) ^{Note}
On (ACPI G0 – working state)	More than six seconds	Fail safe power-off (ACPI G2/G5 – Soft off)
Sleep (ACPI G1 – sleeping state)	Less than four seconds	Wake-up (ACPI G0 – working state)
Sleep (ACPI G1 – sleeping state)	More than six seconds	Power-off (ACPI G2/G5 – Soft off)

Note: Depending on power management settings in the operating system.

1.12.1.1 System States and Power States

Under ACPI, the operating system directs all system and device power state transitions. The operating system puts devices in and out of low-power states based on user preferences and knowledge of how devices are being used by applications. Devices that are not being used can be turned off. The operating system uses information from applications and user settings to put the system as a whole into a low-power state.

Table 11 lists the power states supported by the board along with the associated system power targets. See the ACPI specification for a complete description of the various system and power states.

Table 11. Power States and Targeted System Power

Global States	Sleeping States	Processor States	Device States	Targeted System Power ^(Note 1)
G0 – working state	S0 – working	C0 – working	D0 – working state.	Full power > 30 W
G1 – sleeping state	S3 – Suspend to RAM. Context saved to RAM.	No power	D3 – no power except for wake-up logic.	Power < 5 W ^(Note 2)
G1 – sleeping state	S4 – Suspend to disk. Context saved to disk.	No power	D3 – no power except for wake-up logic.	Power < 5 W ^(Note 2)
G2/S5	S5 – Soft off. Context not saved. Cold boot is required.	No power	D3 – no power except for wake-up logic.	Power < 5 W ^(Note 2)
G3 – mechanical off AC power is disconnected from the computer.	No power to the system.	No power	D3 – no power for wake-up logic, except when provided by battery or external source.	No power to the system. Service can be performed safely.

Notes:

1. Total system power is dependent on the system configuration, including add-in boards and peripherals powered by the system chassis' power supply.
2. Dependent on the standby power consumption of wake-up devices used in the system.

1.12.1.2 Wake-up Devices and Events

Table 12 lists the devices or specific events that can wake the computer from specific states.

Table 12. Wake-up Devices and Events

Devices/events that wake up the system...	...from this sleep state	Comments
Power switch	S3, S4, S5 ¹	
RTC alarm	S3, S4, S5 ¹	Monitor to remain in sleep state
LAN	S3, S4, S5 ^{1,3}	"S5 WOL after G3" must be supported; monitor to remain in sleep state
USB	S3, S4, S5 ^{1,2,3}	Wake S4, S5 controlled by BIOS option (not after G3)
WAKE#	S3, S4 ¹	Via WAKE; monitor to remain in sleep state
Consumer IR	S3, S4, S5 ^{1,3}	Will not wake when in Deep S4/S5 sleep state
Bluetooth	N/A	Wake from Bluetooth is not supported

Notes:

1. S4 implies operating system support only.
2. Will not wake from Deep S4/S5. USB S4/S5 Power is controlled by BIOS. USB S5 wake is controlled by BIOS. USB S4 wake is controlled by OS driver, not just BIOS option.
3. Windows 8.1 Fast startup will block wake from LAN, USB, and CIR from S5.



NOTE

The use of these wake-up events from an ACPI state requires an operating system that provides full ACPI support. In addition, software, drivers, and peripherals must fully support ACPI wake events.

1.12.2 Hardware Support

The board provides several power management hardware features, including:

- Wake from Power Button signal
- Instantly Available PC technology
- LAN wake capabilities
- Wake from USB (not after G3)
- WAKE# signal wake-up support
- Wake from S5
- Wake from CIR
- +5 V Standby Power Indicator LED



NOTE

The use of Wake from USB from an ACPI state requires an operating system that provides full ACPI support.

1.12.2.1 Power Input

When resuming from an AC power failure, the computer returns to the power state it was in before power was interrupted (on or off). The computer's response can be set using the Last Power State feature in the BIOS Setup program's Boot menu.

1.12.2.2 Instantly Available PC Technology

Instantly Available PC technology enables the board to enter the ACPI S3 (Suspend-to-RAM) sleep-state. While in the S3 sleep-state, the computer will appear to be off (the power supply is only supplying Standby power, and the front panel LED will be amber or secondary color if dual colored, or off if single colored.) When signaled by a wake-up device or event, the system quickly returns to its last known wake state. Table 12 on page 37 lists the devices and events that can wake the computer from the S3 state.

The use of Instantly Available PC technology requires operating system support and drivers for any installed M.2 add-in card.

1.12.2.3 LAN Wake Capabilities

LAN wake capabilities enable remote wake-up of the computer through a network. The LAN subsystem monitors network traffic at the Media Independent Interface. Upon detecting a Magic Packet* frame, the LAN subsystem asserts a wake-up signal that powers up the computer.

1.12.2.4 Wake from USB

USB bus activity wakes the computer from an ACPI S3 state (not after G3).



NOTE

Wake from USB requires the use of a USB peripheral that supports Wake from USB.

1.12.2.5 WAKE# Signal Wake-up Support

When the WAKE# signal on the PCI Express bus is asserted, the computer wakes from an ACPI S3 or S4 state.

1.12.2.6 Wake from S5

When the RTC Date and Time is set in the BIOS, the computer will automatically wake from an ACPI S5 state.

1.12.2.7 Wake from Consumer IR

CIR activity wakes the computer from an ACPI S3, S4, or S5 state.

1.12.2.8 +5 V Standby Power Indicator LED

The standby power indicator LED shows that power is still present even when the computer appears to be off. Figure 8 shows the location of the standby power LED.



CAUTION

If AC power has been switched off and the standby power indicator is still lit, disconnect the power cord before installing or removing any devices connected to the board. Failure to do so could damage the board and any attached devices.

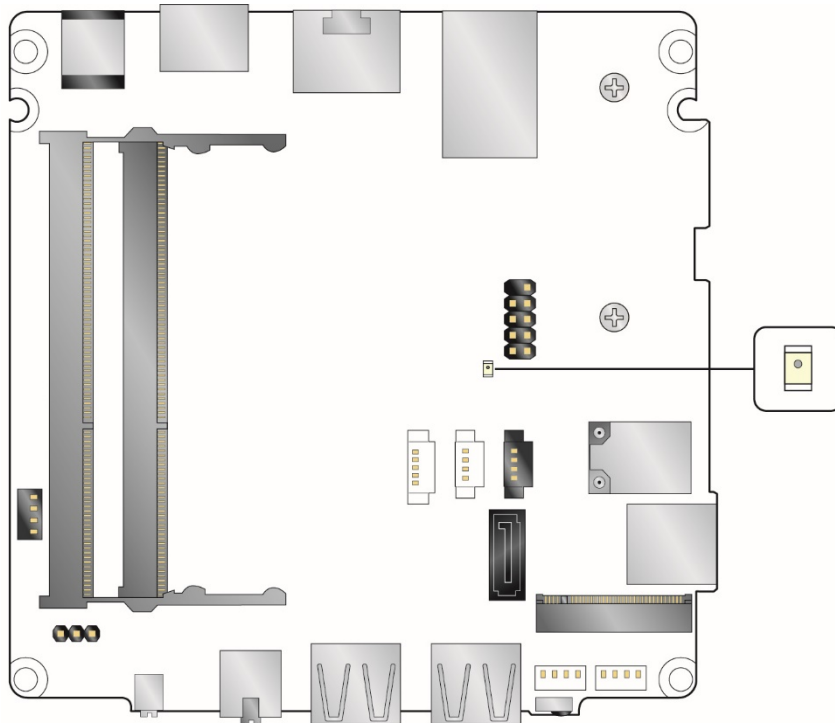

24281

Figure 8. Location of the Standby Power LED

1.13 Intel Platform Security Technologies

Intel platform security technologies provides tools and resources to help the user protect their information by creating a safer computing environment.



NOTE

Software with security capability is required to take advantage of Intel platform security technologies.

1.13.1 Intel® Virtualization Technology

Intel Virtualization Technology (Intel® VT) is a hardware-assisted technology that, when combined with software-based virtualization solutions, provides maximum system utilization by consolidating multiple environments into a single server or client.



NOTE

A processor with Intel VT does not guarantee that virtualization will work on your system. Intel VT requires a computer system with a chipset, BIOS, enabling software and/or operating system, device drivers, and applications designed for this feature.

For information about	Refer to
Intel Virtualization Technology	http://www.intel.com/technology/virtualization/technology.htm

1.13.2 Intel® Platform Trust Technology

Intel® Platform Trust Technology (Intel® PTT) is a platform functionality for credential storage and key management. Intel® PTT supports Microsoft* BitLocker* Drive Encryption for hard drive encryption and supports all Microsoft requirements for firmware Trusted Platform Module (fTPM) 2.0.



NOTE

Support for fTPM version 2.0 requires a UEFI-enabled operating system, such as Microsoft Windows* 10.*



CAUTION

BIOS recovery using the BIOS security jumper clears Intel® Platform Trust Technology (Intel® PTT) keys. These keys will not be restored after the BIOS recovery.

For information about	Refer to
Intel Platform Trust Technology	http://www.intel.com/content/dam/www/public/us/en/documents/white-papers/enterprise-security-platform-trust-technology-white-paper.pdf

2 Technical Reference

2.1 Memory Resources

2.1.1 Addressable Memory

The board utilizes 32 GB of addressable system memory. Typically the address space that is allocated for PCI Conventional bus add-in cards, PCI Express configuration space, BIOS (SPI Flash device), and chipset overhead resides above the top of DRAM (total system memory). On a system that has 32 GB of system memory installed, it is not possible to use all of the installed memory due to system address space being allocated for other system critical functions. These functions include the following:

- BIOS/SPI Flash device (64 Mb)
- Local APIC (19 MB)
- Direct Media Interface (40 MB)
- PCI Express configuration space (256 MB)
- PCH base address registers PCI Express ports (up to 256 MB)
- Memory-mapped I/O that is dynamically allocated for M.2 add-in cards (256 MB)
- Integrated graphics shared memory (up to 512 MB; 64 MB by default)

The board provides the capability to reclaim the physical memory overlapped by the memory mapped I/O logical address space. The board remaps physical memory from the top of usable DRAM boundary to the 4 GB boundary to an equivalent sized logical address range located just above the 4 GB boundary. All installed system memory can be used when there is no overlap of system addresses.

2.2 Connectors and Headers



CAUTION

Only the following connectors and headers have overcurrent protection: back panel and front panel USB.

The other internal connectors and headers are not overcurrent protected and should connect only to devices inside the computer's chassis, such as fans and internal peripherals. Do not use these connectors or headers to power devices external to the computer's chassis. A fault in the load presented by the external devices could cause damage to the computer, the power cable, and the external devices themselves.

Furthermore, improper connection of USB header single wire connectors may eventually overload the overcurrent protection and cause damage to the board.

This section describes the board's connectors and headers. The connectors and headers can be divided into these groups:

- Front panel I/O connectors
- Back panel I/O connectors

2.2.1 Front Panel Connectors

Figure 9 shows the location of the front panel connectors for the board.

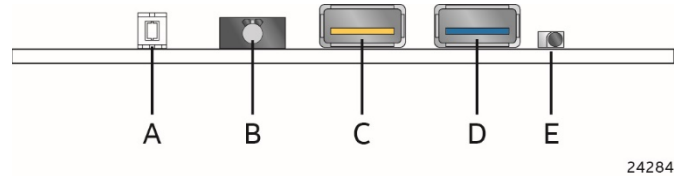

Item	Description
A	Front panel power button
B	Front panel Stereo microphone/headphone jack
C	USB 3.0 ports (orange charging capable)
D	USB 3.0 (blue)
E	CIR

Figure 9. Front Panel Connectors

2.2.2 Back Panel Connectors

Figure 10 shows the location of the back panel connectors for the board.

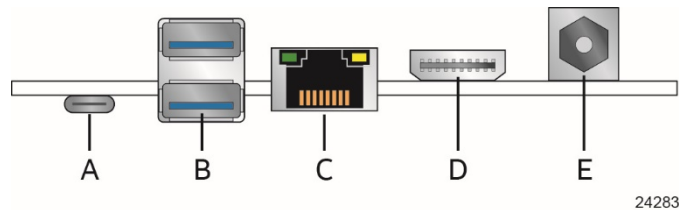

Item	Description
A	USB Type-C connector
B	USB 3.0 ports (blue)
C	LAN
D	HDMI connector
E	12-19 V DC input jack

Figure 10. Back Panel Connectors

2.2.3 Headers and Connectors (Top)

Figure 11 shows the location of the headers and connectors on the top-side of the board.

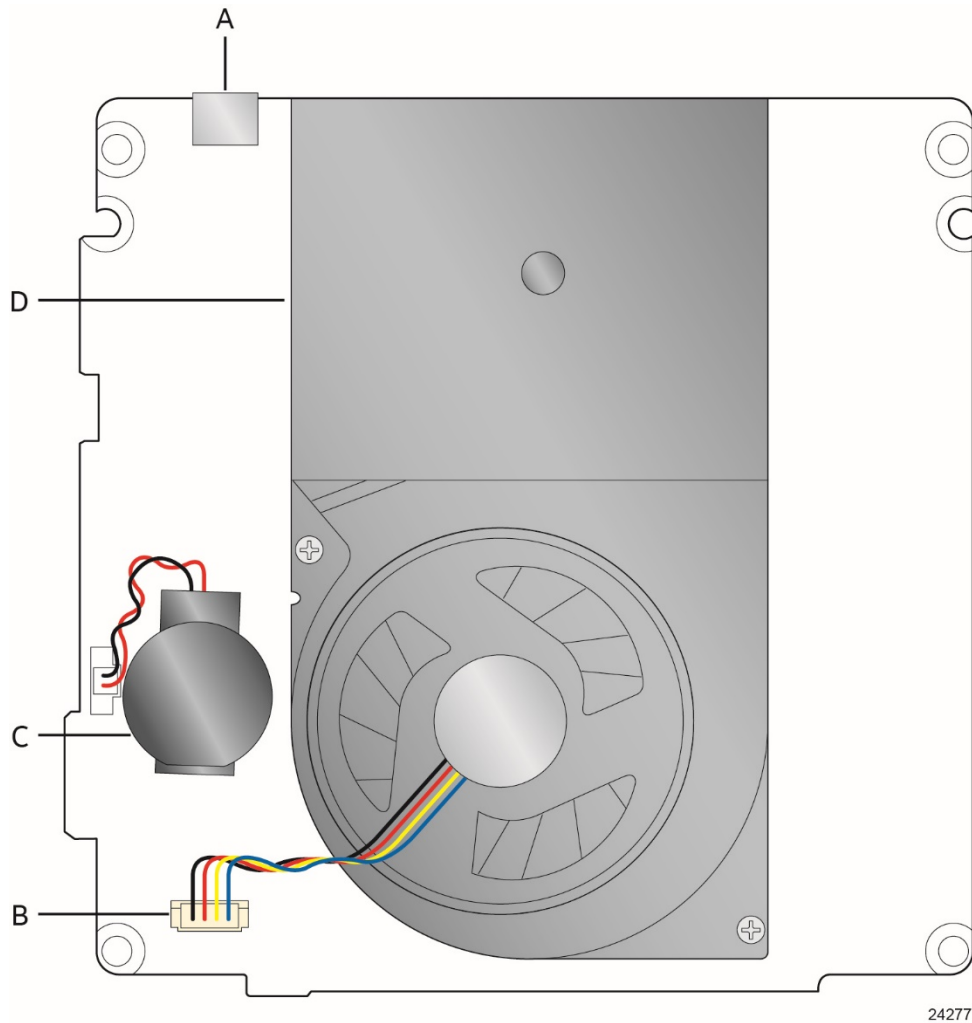

Figure 11. Headers and Connectors (Top)

Table 13 lists the headers and connectors identified in Figure 11.

Table 13. Headers and Connectors Shown in Figure 11

Item from Figure 11	Description
A	USB Type-C connector
B	Processor fan header
C	Battery and header
D	Thermal solution

2.2.4 Connectors and Headers (Bottom)

Figure 12 shows the locations of the connectors and headers on the bottom-side of the board.

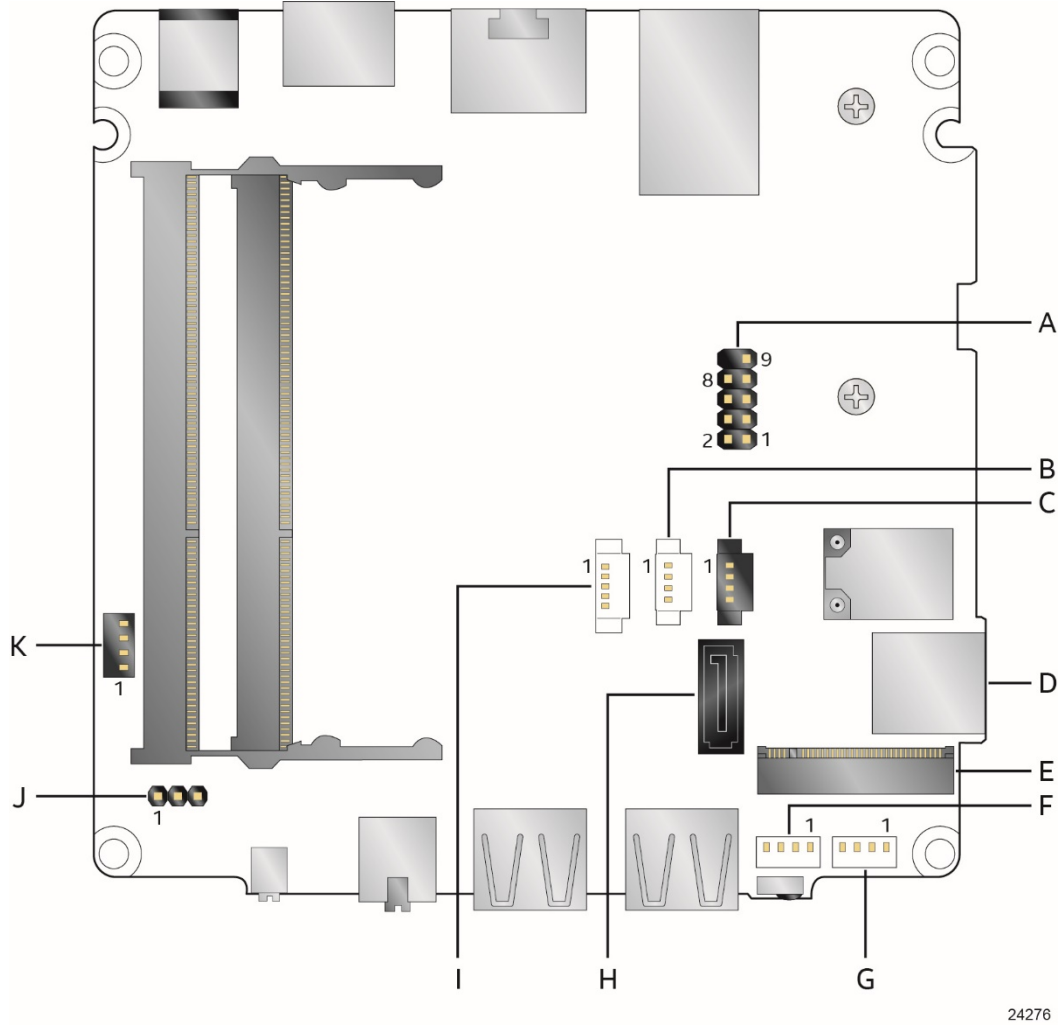

24276

Figure 12. Connectors and Headers (Bottom)

Table 14 lists the connectors and headers identified in Figure 12.

Table 14. Connectors and Headers Shown in Figure 12

Item from Figure 12	Description
A	Front panel header
B	Digital microphone array connector
C	Front panel LED ring connector
D	Micro SDXC slot
E	M.2 connector (key type M) for 2242 and 2280 modules
F	Front panel single-port USB 2.0 header (1.25 mm pitch)
G	Front panel single-port USB 2.0 header (1.25 mm pitch)
H	SATA 6.0 Gb/s connector
I	SATA power connector (1.25 mm pitch)
J	BIOS security jumper
K	Consumer electronics control (CEC) header

2.2.4.1 Signal Tables for the Connectors and Headers

Table 15. SATA Power Connector (1.25 mm pitch)

Pin	Signal Name
1	+5 V
2	+5 V
3	+3.3 V
4	GND
5	GND



NOTE

Connector is Molex* part number 53398-0571, 1.25 mm pitch PicoBlade* header, surface mount, vertical, lead-free, 5 circuits.

Table 16. Single-Port Internal USB 2.0 Header (1.25 mm pitch)

Pin	Signal Name	Pin	Signal Name
1	+5 V DC	2	D-
3	D+	4	Ground



NOTE

Connector is Molex part number 53398-0471, 1.25 mm pitch PicoBlade header, surface mount, vertical, lead-free, 4 circuits.

Table 17. M.2 2280 Module (key type M) Connector

Pin	Signal Name	Pin	Signal Name
74	3.3V	75	GND
72	3.3V	73	GND
70	3.3V	71	GND
68	SUSCLK(32kHz) (O)(0/3.3V)	69	PEDET (NC-PCIe/GND-SATA)
66	Connector Key	67	N/C
64	Connector Key	65	Connector Key
62	Connector Key	63	Connector Key
60	Connector Key	61	Connector Key
58	N/C	59	Connector Key
56	N/C	57	GND

continued

Table 17. M.2 2280 Module (key type M) Connector (continued)

Pin	Signal Name	Pin	Signal Name
54	PEWAKE# (I/O)(0/3.3V) or N/C	55	REFCLKP
52	CLKREQ# (I/O)(0/3.3V) or N/C	53	REFCLKN
50	PERST# (O)(0/3.3V) or N/C	51	GND
48	N/C	49	PETp0/SATA-A+
46	N/C	47	PETn0/SATA-A-
44	N/C	45	GND
42	N/C	43	PERp0/SATA-B-
40	N/C	41	PERn0/SATA-B+
38	DEVSLP (O)	39	GND
36	N/C	37	PETp1
34	N/C	35	PETn1
32	N/C	33	GND
30	N/C	31	PERp1
28	N/C	29	PERn1
26	N/C	27	GND
24	N/C	25	PETp2
22	N/C	23	PETn2
20	N/C	21	GND
18	3.3V	19	PERp2
16	3.3V	17	PERn2
14	3.3V	15	GND
12	3.3V	13	PETp3
10	DAS/DSS# (I/O)/LED1# (I)(0/3.3V)	11	PETn3
8	N/C	9	GND
6	N/C	7	PERp3
4	3.3V	5	PERn3
2	3.3V	3	GND
		1	GND

Table 18. Digital Microphone (DMICS) Array Connector (1.25 mm Pitch)

Pin	Signal Name
1	Ground
2	+3.3 V DC (+3V3_DMIC)
3	Clock (DMIC_CLK)
4	Data (DMIC_DAT)



NOTE

Connector is Aces part number 50273-0047C-002, 1.25 mm pitch header, surface mount, vertical, lead-free, 4 circuits.

Table 19. Front Panel HDD LED Ring Connector (1.25 mm Pitch)

Pin	Signal Name
1	+5VSB
2	Red HDD LED
3	Green HDD LED
4	Blue HDD LED



NOTE

Connector is Aces part number 50273-0047C-002, 1.25 mm pitch header, surface mount, vertical, lead-free, 4 circuits.

Table 20. CEC Header (1.25 mm pitch)

Pin	Signal Name
1	5VSTBY
2	GND
3	PWR_SWITCH#
4	HDMI_CEC



NOTE

Connector is Aces part number 50273-0047C-002, 1.25 mm pitch header, surface mount, vertical, lead-free, 4 circuits.

2.2.4.2 Add-in Card Connectors

The board supports M.2 2242 and 2280 (key type M) modules.

- Supports M.2 SSD SATA drives
 - Maximum bandwidth is approximately 540 MB/s
- Supports M.2 SSD Gen 3 PCIe AHCI and NVMe drives (PCIe x1, x2, and x4)
 - Using PCIe x4 M.2 SSD maximum bandwidth is approximately 4000 MB/s

2.2.4.3 USB Type-C connector

The board has several features that are supported via the USB Type-C connector.

- Supports USB 3.1 Gen 2.0
 - Maximum bandwidth is approximately 10 Gbit/s
- Supports Display port 1.2
 - Maximum bandwidth is approximately 17.28 Gbit/s

2.2.4.4 Front Panel Header (2.0 mm Pitch)

This section describes the functions of the front panel header. Table 21 lists the signal names of the front panel header. Figure 13 is a connection diagram for the front panel header.

Table 21. Front Panel Header (2.0 mm Pitch)

Pin	Signal Name	Description	Pin	Signal Name	Description
1	HDD_POWER_LED	Pull-up resistor (750 Ω) to +5V	2	POWER_LED_MAIN	[Out] Front panel LED (main color)
3	HDD_LED#	[Out] Hard disk activity LED	4	POWER_LED_ALT	[Out] Front panel LED (alt color)
5	GROUND	Ground	6	POWER_SWITCH#	[In] Power switch
7	RESET_SWITCH#	[In] Reset switch	8	GROUND	Ground
9	+5V_DC	Power	10	Key	No pin

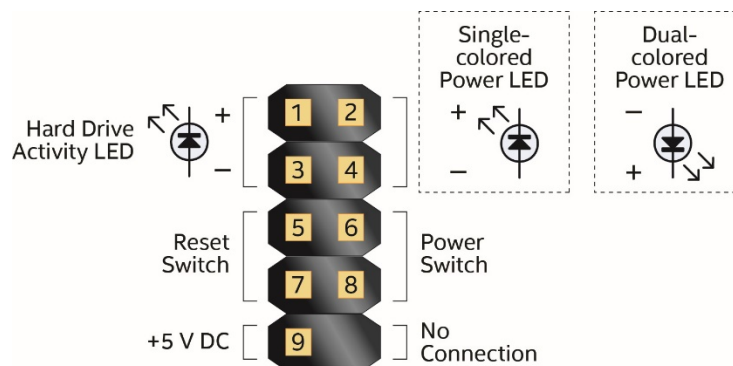

24273

Figure 13. Connection Diagram for Front Panel Header (2.0 mm Pitch)

2.2.4.4.1 Hard Drive Activity LED Header

Pins 1 and 3 can be connected to an LED to provide a visual indicator that data is being read from or written to a hard drive. Proper LED function requires a SATA hard drive or optical drive connected to an onboard SATA connector.

2.2.4.4.2 Reset Switch Header

Pins 5 and 7 can be connected to a momentary single pole, single throw (SPST) type switch that is normally open. When the switch is closed, the board resets and runs the POST.

2.2.4.4.3 Power/Sleep LED Header

Pins 2 and 4 can be connected to a one- or two-color LED. Table 22 and Table 23 show the possible LED states.

Table 22. States for a One-Color Power LED

LED State	Description
Off	Power off
Blinking	Standby
Steady	Normal operation

Table 23. States for a Dual-Color Power LED

LED State	Description
Off	Power off
Secondary color blinking (amber)	Standby
Primary color steady (white)	Normal operation



NOTE

The LED behavior shown in Table 22 is default – other patterns may be set via BIOS setup.

2.2.4.4.4 Power Switch Header

Pins 6 and 8 can be connected to a front panel momentary-contact power switch. The switch must pull the SW_ON# pin to ground for at least 50 ms to signal the power supply to switch on or off. (The time requirement is due to internal debounce circuitry on the board.) At least two seconds must pass before the power supply will recognize another on/off signal.

2.2.4.5 Micro SDXC Card Reader

The board has a micro Secure Digital (Micro SD) card reader that supports the Secure Digital eXtended Capacity (SDXC) format, 3.01 specification.

Table 24. SDXC Card Reader Connector

Pin	Signal Name	Descriptive Name
1	CD	Card Detection
2	DATA1	Serial Data 1
3	DATA0	Serial Data 0
4	GND	Ground
5	CLK	Serial Clock
6	VDD	Power (3.3 V)
7	CMD	Command
8	DATA3	Serial Data 3
9	DATA2	Serial Data 2



NOTE

The Micro SDXC card reader is not supported in Microsoft Windows* 7*

2.2.4.6 Power Supply Connector

The board has the following power supply connector:

- **External Power Supply** – the board can be powered through a 12-19 V DC connector on the back panel. The back panel DC connector is compatible with a 5.5 mm/OD (outer diameter) and 2.5 mm/ID (inner diameter) plug, where the inner contact is +12-19 ($\pm 10\%$) V DC and the shell is GND. The maximum current rating is 10 A.



NOTE

External power voltage, 12-19 V DC, is dependent on the type of power brick used.

2.2.4.6.1 Power Sensing Circuit

The board has a power sensing circuit that:

- Manages CPU power usage to maintain system power consumption below 65 W.
- Designed for use with 65 W AC-DC adapters.



NOTE

It is recommended that you disable this feature (via BIOS option) when using an AC-DC adapter greater than 65 W.

2.2.4.7 Internal USB 2.0 Single-Port Header (1.25 mm Pitch)

Figure 14 is a connection diagram for the internal USB header.



NOTE

- The +5 V DC power on the USB header is fused.
- Use only an internal USB connector that conforms to the USB 2.0 specification for high-speed USB devices.

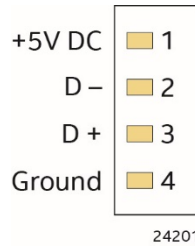

Figure 14. Connection Diagram for the Internal USB 2.0 Single-Port Header (1.25 mm Pitch)

2.2.4.8 Consumer Infrared (CIR) Sensor

The Consumer Infrared (CIR) sensor on the front panel provides features that are designed to comply with Microsoft Consumer Infrared usage models (RC-6).

The CIR feature is made up of the receiving sensor. The receiving sensor consists of a filtered translated infrared input compliant with Microsoft CIR specifications.

Customers are required to provide their own media center compatible remote or smart phone application for use with the Intel NUC. Figure 15 shows the location of the CIR sensor.

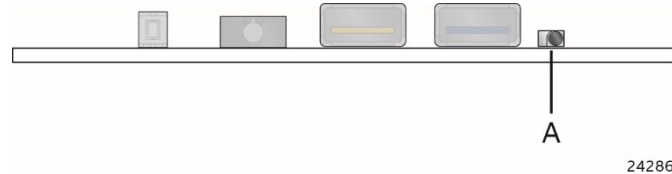

Item	Description
A	CIR Sensor

Figure 15. Location of the CIR Sensor

2.2.4.9 Consumer Electronics Control (CEC) Header

The board contains two mutually-exclusive methods for controlling HDMI CEC devices:

- External CEC adaptor connected via CEC connector (item K in Figure 12; pinout in Table 20)
- Onboard CEC control from the embedded controller via HDMI cable and BIOS setup. Expected behavior is provided in Table 25 below.

Table 25. HDMI CEC expected behavior

Activity	Current Status		Action	Expected Behavior
	PC ^{1,2}	TV ³		
Wake On TV	Off	Off	TV on	PC on
Standby by TV	On	On	TV Standby	PC sleep or power off ⁴
Auto Turn Off TV (S0 -> S5)	On	On	PC Shutdown	TV standby ³
Auto Turn On TV (S5 -> S0)	Off	Off	PC On	TV on ³
Auto Turn Off TV (S0 -> S3)	On	On	PC Sleep	TV standby ³
Auto Turn On TV (S3 -> S0)	Off	Off	PC On	TV on ³

Notes:

1. *HDMI CEC Control* enabled in BIOS Setup and in TV setup, if necessary. Please consult your TV's documentation.
2. *Fast Boot* and *Deep S4/S5* disabled in BIOS Setup.
3. Results seen with Panasonic LED TV VIERA TH-40A400W. Other TVs may have different results due to variable implementations of CEC features.
4. PC power off behavior dependent upon power button setting in operating system.
5. If using external CEC adaptor, onboard CEC control must be disabled in BIOS Setup.

**NOTE**

CEC Connector is Aces part number 50273-0047C-002, 1.25 mm pitch header, surface mount, vertical, lead-free, 4 circuits.

For information about

HDMI CEC technology

Refer to
<http://www.hdmi.org/pdf/whitepaper/DesigningCECintoYourNextHDMIProduct.pdf>
2.2.4.10 Front Panel HDD LED Ring

The board supports a front panel HDD LED ring which is connected through Item C shown in Figure 12. The Front panel HDD LED Ring is configurable within the bios under the *Power* tab within *Advanced* settings. Table 19 lists the signal names of the front panel HDD LED ring connector.

Table 26. Front Panel LED Ring

Bios Option	Possible Configurations
Front Panel HDD LED Ring Color	Yellow, cyan, magenta, blue, red, green and white.
Front Panel HDD LED Ring Brightness	0%, 50% 100%
Front Panel HDD LED Ring Activity Indicator	None, Power indicator, HDD Activity or Software defined

2.2.4.11 Digital Microphone Array

The digital microphone array consists of dual front facing digital microphones located on either side of the front panel HDD LED ring to minimize acoustic interference. Item L in Figure 12 shows the location of the digital microphone array connector. Table 18 lists the signal names of the DMIC connector. See Chapter 5 for the physical location of the DMIC array on the Intel NUC Kit NUC7i3BN[x] chassis.

2.3 BIOS Security Jumper



CAUTION

Do not move a jumper with the power on. Always turn off the power and unplug the power cord from the computer before changing a jumper setting. Otherwise, the board could be damaged.

Figure 16 shows the location of the BIOS Security Jumper. The 3-pin jumper determines the BIOS Security program's mode.

Table 27 describes the jumper settings for the three modes: normal, lockdown, and configuration.

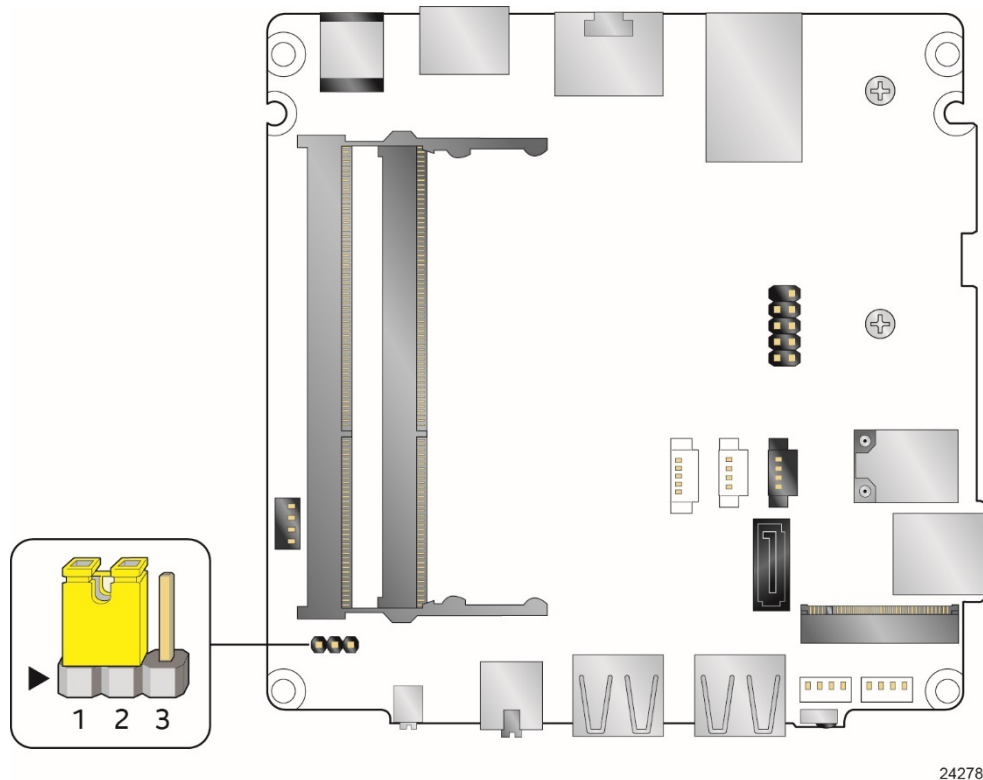

Figure 16. Location of the BIOS Security Jumper

Table 27. BIOS Security Jumper Settings

Function/Mode	Jumper Setting	Configuration
Normal	1-2	The BIOS uses current configuration information and passwords for booting.
Lockdown	2-3	<p>The BIOS uses current configuration information and passwords for booting, except:</p> <ul style="list-style-type: none">• All POST Hotkeys are suppressed (prompts are not displayed and keys are not accepted. For example, F2 for Setup, F10 for the Boot Menu).• Power Button Menu is not available (see Section 3.7.4 Power Button Menu). <p>BIOS updates are not available except for automatic Recovery due to flash corruption.</p>
Configuration	None	<p>BIOS Recovery Update process if a matching *.bio file is found. Recovery Update can be cancelled by pressing the Esc key.</p> <p>If the Recovery Update was cancelled or a matching *.bio file was not found, a Config Menu will be displayed. The Config Menu consists of the following (selected Power Button Menu options):</p> <p>[1] Suppress this menu until the BIOS Security Jumper is replaced.</p> <p>[2] Clear BIOS User and Supervisor Passwords.</p> <p>See Section 3.7.4 Power Button Menu.</p>

2.4 Mechanical Considerations

2.4.1 Form Factor

The board is designed to fit into a custom chassis. Figure 17 illustrates the mechanical form factor for the board. Dimensions are given in inches [millimeters].

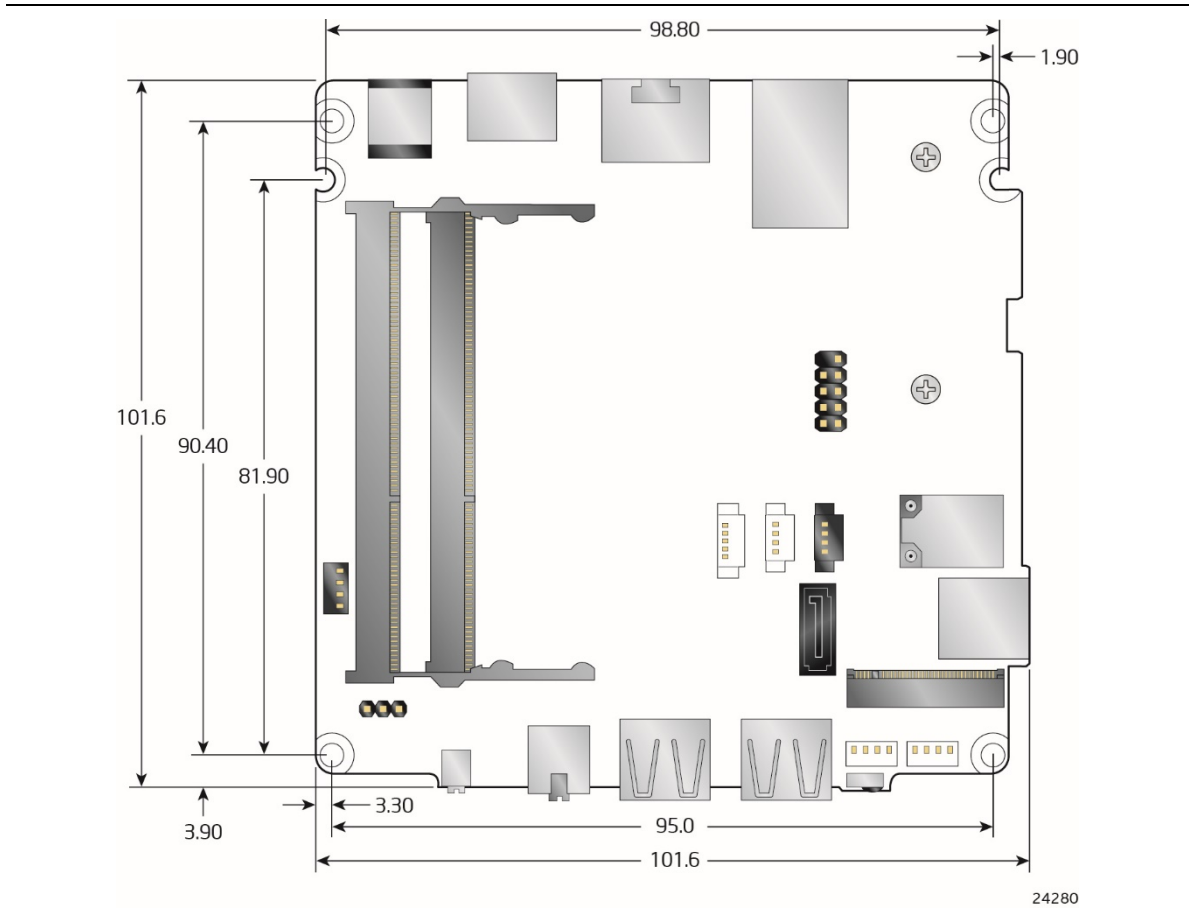

Figure 17. Board Dimensions

Figure 18 shows the height dimensions of the board.

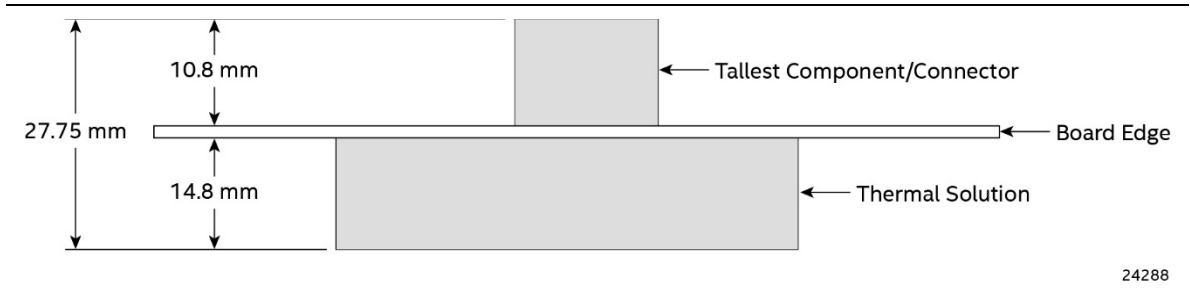

Figure 18. Board Height Dimensions

2.5 Electrical Considerations

2.5.1 Power Supply Considerations

System power requirements will depend on actual system configurations chosen by the integrator, as well as end user expansion preferences. It is the system integrator's responsibility to ensure an appropriate power budget for the system configuration is properly assessed based on the system-level components chosen.

2.5.2 Fan Header Current Capability

Table 28 lists the current capability of the fan header.

Table 28. Fan Header Current Capability

Fan Header	Maximum Available Current
Processor fan	.5 A

2.6 Thermal Considerations



CAUTION

A chassis with a maximum internal ambient temperature of 50 °C at the processor fan inlet is recommended. If the internal ambient temperature exceeds 50 °C, further thermal testing is required to ensure components do not exceed their maximum case temperature.



CAUTION

Failure to ensure appropriate airflow may result in reduced performance of both the processor and/or voltage regulator or, in some instances, damage to the board.

All responsibility for determining the adequacy of any thermal or system design remains solely with the system integrator. Intel makes no warranties or representations that merely following the instructions presented in this document will result in a system with adequate thermal performance.



CAUTION

Ensure that the ambient temperature does not exceed the board's maximum operating temperature. Failure to do so could cause components to exceed their maximum case temperature and malfunction. For information about the maximum operating temperature, see the environmental specifications in Section 2.8.



CAUTION

Ensure that proper airflow is maintained in the processor voltage regulator circuit. Failure to do so may result in shorter than expected product lifetime.

Figure 19 shows the locations of the localized high temperature zones.

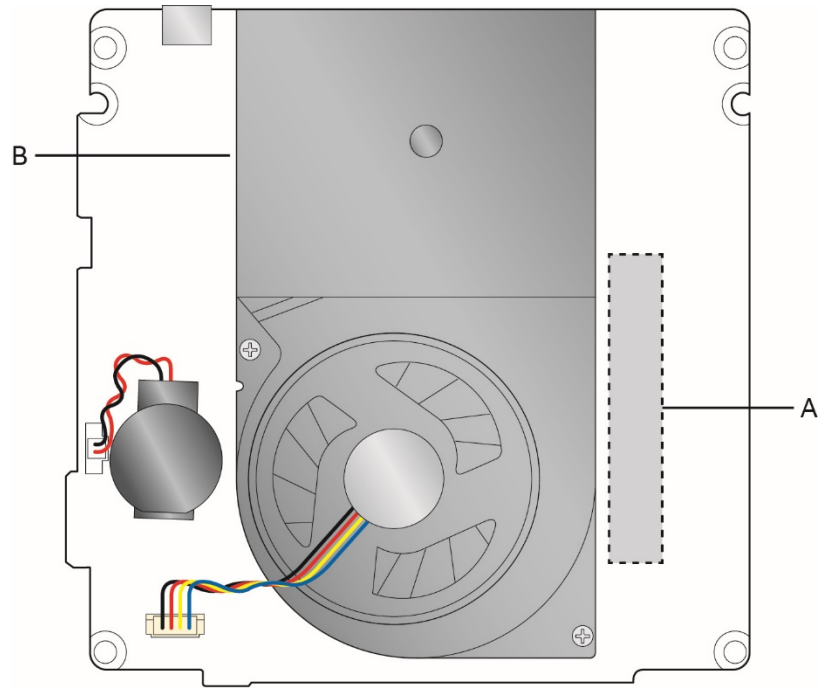

24289

Item	Description
A	Processor voltage regulator area
B	Thermal solution

Figure 19. Localized High Temperature Zones

A thermal pad has been installed for the bottom of the chassis to improve the thermal performance when using M.2 devices that operate at higher temperatures. If the thermal pad ever needs to be replaced, Figure 20 shows the installation area of the thermal pad for the Intel NUC Kit NUC7i3BNK.

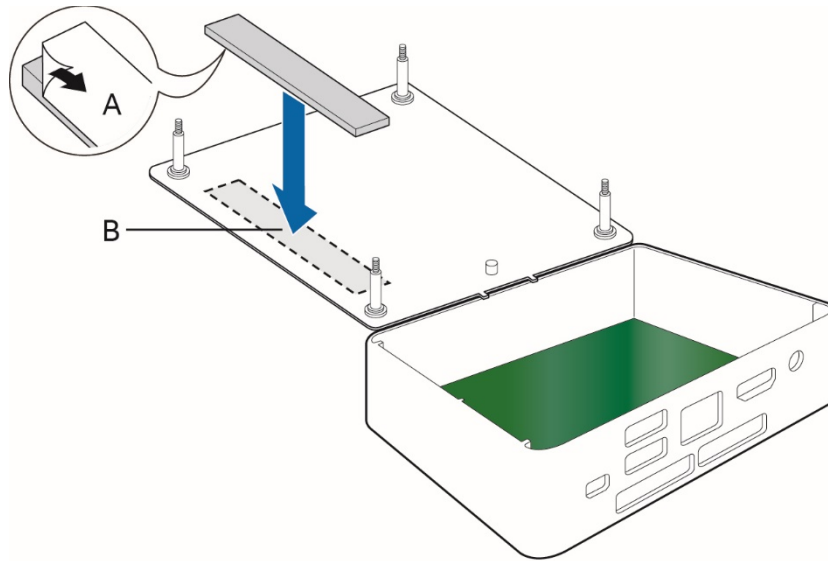

24292

Item	Description
A	Thermal Pad
B	Thermal Pad Installation Area

Figure 20. Installation Area of Thermal Pad for Intel NUC Kit NUC7i3BNK

Figure 21 shows the installation area of the thermal pad for the Intel NUC Kit NUC7i3BNH.

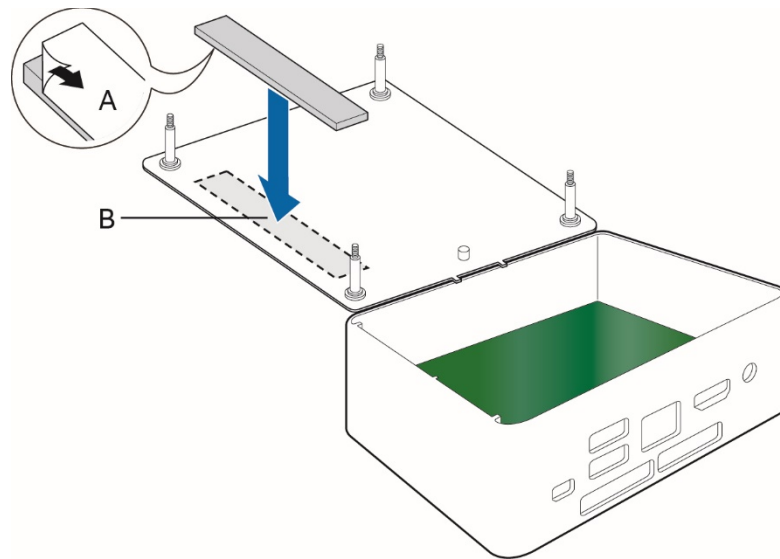

24293

Item	Description
A	Thermal Pad
B	Thermal Pad Installation Area

Figure 21. Installation area of Thermal Pad for Intel NUC Kit NUC7i3BNH

Table 29 provides maximum case temperatures for the components that are sensitive to thermal changes. The operating temperature, current load, or operating frequency could affect case temperatures. Maximum case temperatures are important when considering proper airflow to cool the board.

Table 29. Thermal Considerations for Components

Component	Maximum Case Temperature
Processor	For processor case temperature, see processor datasheets and processor specification updates

To ensure functionality and reliability, the component is specified for proper operation when Case Temperature is maintained at or below the maximum temperature listed in Table 30. This is a requirement for sustained power dissipation equal to Thermal Design Power (TDP is specified as the maximum sustainable power to be dissipated by the components). When the component is dissipating less than TDP, the case temperature should be below the Maximum Case Temperature. The surface temperature at the geometric center of the component corresponds to Case Temperature.

It is important to note that the temperature measurement in the system BIOS is a value reported by embedded thermal sensors in the components and does not directly correspond to the Maximum Case Temperature. The upper operating limit when monitoring this thermal sensor is Tcontrol.

Table 30. Tcontrol Values for Components

Component	Tcontrol
Processor	For processor case temperature, see processor datasheets and processor specification updates

For information about	Refer to
Processor datasheets and specification updates	Section 1.2, page 22

2.7 Reliability

The Mean Time Between Failures (MTBF) prediction is calculated using component and subassembly random failure rates. The calculation is based on the Telcordia SR-332 Issue 2, Method I, Case 3, 55 °C ambient. The MTBF prediction is used to estimate repair rates and spare parts requirements. The MTBF for Intel NUC7i3BNB board is 62,965.

2.8 Environmental

Table 31 lists the environmental specifications for the board.

Table 31. Environmental Specifications

Parameter	Specification		
Temperature			
Non-Operating	-40 °C to +60 °C		
Operating	0 °C to +35 °C The operating temperature of the board may be determined by measuring the air temperature from the junction of the heatsink fins and fan, next to the attachment screw, in a closed chassis, while the system is in operation.		
Shock			
Unpackaged	50 g trapezoidal waveform Velocity change of 170 inches/s ²		
Packaged	Half sine 2 millisecond		
	Product Weight (pounds)	Free Fall (inches)	Velocity Change (inches/s ²)
	<20	36	167
	21-40	30	152
	41-80	24	136
	81-100	18	118
Vibration			
Unpackaged	5 Hz to 20 Hz: 0.01 g ² Hz sloping up to 0.02 g ² Hz 20 Hz to 500 Hz: 0.02 g ² Hz (flat)		
Packaged	5 Hz to 40 Hz: 0.015 g ² Hz (flat) 40 Hz to 500 Hz: 0.015 g ² Hz sloping down to 0.00015 g ² Hz		

Note: Before attempting to operate this board, the overall temperature of the board must be above the minimum operating temperature specified. It is recommended that the board temperature be at least room temperature before attempting to power on the board. The operating and non-operating environment must avoid condensing humidity.

3 Overview of BIOS Features

3.1 Introduction

The board uses Intel Visual BIOS that is stored in the Serial Peripheral Interface Flash Memory (SPI Flash) and can be updated using a disk-based program. The SPI Flash contains the Visual BIOS Setup program, POST, the PCI auto-configuration utility, LAN EEPROM information, and Plug and Play support.

The BIOS displays a message during POST identifying the type of BIOS and a revision code. The initial production BIOSs are identified as BNKBL357.86A.

The Visual BIOS Setup program can be used to view and change the BIOS settings for the computer. The BIOS Setup program is accessed by pressing the <F2> key after the Power-On Self-Test (POST) memory test begins and before the operating system boot begins.



NOTE

The maintenance menu is displayed only when the board is in configure mode. Section 2.3 on page 55 shows how to put the board in configure mode.

3.2 BIOS Flash Memory Organization

The Serial Peripheral Interface Flash Memory (SPI Flash) includes a 64 Mb flash memory device.

3.3 System Management BIOS (SMBIOS)

SMBIOS is a Desktop Management Interface (DMI) compliant method for managing computers in a managed network.

The main component of SMBIOS is the Management Information Format (MIF) database, which contains information about the computing system and its components. Using SMBIOS, a system administrator can obtain the system types, capabilities, operational status, and installation dates for system components. The MIF database defines the data and provides the method for accessing this information. The BIOS enables applications such as third-party management software to use SMBIOS. The BIOS stores and reports the following SMBIOS information:

- BIOS data, such as the BIOS revision level
- Fixed-system data, such as peripherals, serial numbers, and asset tags
- Resource data, such as memory size, cache size, and processor speed
- Dynamic data, such as event detection and error logging

Non-Plug and Play operating systems require an additional interface for obtaining the SMBIOS information. The BIOS supports an SMBIOS table interface for such operating systems. Using this support, an SMBIOS service-level application running on a non-Plug and Play operating system can obtain the SMBIOS information. Additional board information can be found in the BIOS under the Additional Information header under the Main BIOS page.

3.4 Legacy USB Support

Legacy USB support enables USB devices to be used even when the operating system's USB drivers are not yet available. Legacy USB support is used to access the BIOS Setup program, and to install an operating system that supports USB. By default, Legacy USB support is set to Enabled.

Legacy USB support operates as follows:

1. When you apply power to the computer, legacy support is disabled.
2. POST begins.
3. Legacy USB support is enabled by the BIOS allowing you to use a USB keyboard to enter and configure the BIOS Setup program and the maintenance menu.
4. POST completes.
5. The operating system loads. While the operating system is loading, USB keyboards and mice are recognized and may be used to configure the operating system. (Keyboards and mice are not recognized during this period if Legacy USB support was set to Disabled in the BIOS Setup program.)
6. After the operating system loads the USB drivers, all legacy and non-legacy USB devices are recognized by the operating system, and Legacy USB support from the BIOS is no longer used.

To install an operating system that supports USB, verify that Legacy USB support in the BIOS Setup program is set to Enabled and follow the operating system's installation instructions.

3.5 BIOS Updates

The BIOS can be updated using one of the following methods:

- Intel Express BIOS Update Utility, which enables automated updating while in the Windows environment. Using this utility, the BIOS can be updated from a file on a hard disk, a USB drive (a flash drive or a USB hard drive), or a CD-ROM, or from the file location on the Web.
- Intel Flash Memory Update Utility, which requires booting from DOS. Using this utility, the BIOS can be updated from a file on a hard disk, a USB drive (a flash drive or a USB hard drive), or a CD-ROM.
- Intel® F7 switch during POST allows a user to select where the BIOS .bio file is located and perform the update from that location/device. Similar to performing a BIOS Recovery without removing the BIOS configuration jumper.
- Intel® Visual BIOS has an option to update the BIOS from a valid .bio file located on a hard disk or USB drive. Enter Intel Visual BIOS by pressing <F2> during POST.
- Using Front Panel menu option

Both utilities verify that the updated BIOS matches the target system to prevent accidentally installing an incompatible BIOS.



NOTE

Review the instructions distributed with the upgrade utility before attempting a BIOS update.

For information about	Refer to
BIOS update utilities	http://www.intel.com/content/www/us/en/support/boards-and-kits/000005636.html

3.5.1 Language Support

The BIOS Setup program and help messages are supported in US English. Check the Intel web site for support.

3.6 BIOS Recovery

It is unlikely that anything will interrupt a BIOS update; however, if an interruption occurs, the BIOS could be damaged. Table 32 lists the drives and media types that can and cannot be used for BIOS recovery. The BIOS recovery media does not need to be made bootable.

Table 32. Acceptable Drives/Media Types for BIOS Recovery

Media Type ^(Note)	Can be used for BIOS recovery?
Hard disk drive (connected to SATA or USB)	Yes
CD/DVD drive (connected to SATA or USB)	Yes

USB flash drive	Yes
USB diskette drive (with a 1.4 MB diskette)	No (BIOS update file is bigger than 1.4 MB size limit)



NOTE

Supported file systems for BIOS recovery:

- *NTFS (sparse, compressed, or encrypted files are not supported)*
- *FAT32*
- *FAT16*
- *FAT12*
- *ISO 9660*

For information about	Refer to
BIOS recovery	http://www.intel.com/content/www/us/en/support/boards-and-kits/000005532.html

3.7 Boot Options

In the BIOS Setup program, the user can choose to boot from a hard drive, optical drive, removable drive, or the network. The default setting is for the optical drive to be the first boot device, the hard drive second, removable drive third, and the network fourth.



NOTE

Optical drives are not supported by the onboard SATA connectors. Optical drives are supported only via the USB interfaces.

3.7.1 Network Boot

The network can be selected as a boot device. This selection allows booting from the onboard LAN or a network add-in card with a remote boot ROM installed.

Pressing the <F12> key during POST automatically forces booting from the LAN. To use this key during POST, the User Access Level in the BIOS Setup program's Security menu must be set to Full.

3.7.2 Booting Without Attached Devices

For use in embedded applications, the BIOS has been designed so that after passing the POST, the operating system loader is invoked even if the following devices are not present:

- Video adapter
- Keyboard
- Mouse

3.7.3 Changing the Default Boot Device During POST

Pressing the <F10> key during POST causes a boot device menu to be displayed. This menu displays the list of available boot devices. Table 33 lists the boot device menu options.

Table 33. Boot Device Menu Options

Boot Device Menu Function Keys	Description
<↑> or <↓>	Selects a default boot device
<Enter>	Exits the menu, and boots from the selected device
<Esc>	Exits the menu and boots according to the boot priority defined through BIOS setup

3.7.4 Power Button Menu

As an alternative to Back-to-BIOS Mode or normal POST Hotkeys, the user can use the power button to access a menu. The Power Button Menu is accessible via the following sequence:

1. System is in S4/S5 (not G3)
2. User pushes the power button and holds it down for 3 seconds
3. The front panel power button LED will change from Blue to Amber when the user can release the power button.
4. User releases the power button before the 4-second shutdown override

If this boot path is taken, the BIOS will use default settings, ignoring settings in VPD where possible.

At the point where Setup Entry/Boot would be in the normal boot path, the BIOS will display the following prompt and wait for a keystroke:

[ESC] Normal Boot
[F2] Intel Visual BIOS
[F3] Disable Fast Boot
[F4] BIOS Recovery
[F7] Update BIOS
[F10] Enter Boot Menu
[F12] Network Boot

[F2] Enter Setup is displayed instead if Visual BIOS is not supported.

[F3] Disable Fast Boot is only displayed if at least one Fast Boot optimization is enabled.

[F9] Remote Assistance is only displayed if Remote Assistance is supported.

If an unrecognized key is hit, then the BIOS will beep and wait for another keystroke. If one of the listed hotkeys is hit, the BIOS will follow the indicated boot path. Password requirements must still be honored.

If Disable Fast Boot is selected, the BIOS will disable all Fast Boot optimizations and reset the system.

3.8 Hard Disk Drive Password Security Feature

The Hard Disk Drive Password Security feature blocks read and write accesses to the hard disk drive until the correct password is given. Hard Disk Drive Passwords are set in BIOS SETUP and are prompted for during BIOS POST. For convenient support of S3 resume, the system BIOS will automatically unlock drives on resume from S3. Valid password characters are A-Z, a-z, and 0-9. Passwords may be up to 19 characters in length.

The User hard disk drive password, when installed, will be required upon each power-cycle until the Master Key or User hard disk drive password is submitted.

The Master Key hard disk drive password, when installed, will not lock the drive. The Master Key hard disk drive password exists as an unlock override in the event that the User hard disk drive password is forgotten. Only the installation of the User hard disk drive password will cause a hard disk to be locked upon a system power-cycle.

Table 34 shows the effects of setting the Hard Disk Drive Passwords.

Table 34. Master Key and User Hard Drive Password Functions

Password Set	Password During Boot
Neither	None
Master only	None
User only	User only
Master and User Set	Master or User

During every POST, if a User hard disk drive password is set, POST execution will pause with the following prompt to force the user to enter the Master Key or User hard disk drive password:

Enter Hard Disk Drive Password:

Upon successful entry of the Master Key or User hard disk drive password, the system will continue with normal POST.

If the hard disk drive password is not correctly entered, the system will go back to the above prompt. The user will have three attempts to correctly enter the hard disk drive password. After the third unsuccessful hard disk drive password attempt, the system will halt with the message:

Hard Disk Drive Password Entry Error

A manual power cycle will be required to resume system operation.



NOTE

As implemented on Intel NUC Board NUC7i3BNB Hard Disk Drive Password Security is only supported on either SATA port 0 (M.2) or SATA Port 1 (onboard SATA connector). The passwords are stored on the hard disk drive so if the drive is relocated to another computer that does not support Hard Disk Drive Password Security feature, the drive will not be accessible.

Currently, there is no industry standard for implementing Hard Disk Drive Password Security on AHCI or NVME drives. Hard drive encryption can still be implemented and does not require Hard Disk Drive Password Security.

3.9 BIOS Security Features

The BIOS includes security features that restrict access to the BIOS Setup program and who can boot the computer. A supervisor password and a user password can be set for the BIOS Setup program and for booting the computer, with the following restrictions:

- The supervisor password gives unrestricted access to view and change all the Setup options in the BIOS Setup program. This is the supervisor mode.
- The user password gives restricted access to view and change Setup options in the BIOS Setup program. This is the user mode.
- If only the supervisor password is set, pressing the <Enter> key at the password prompt of the BIOS Setup program allows the user restricted access to Setup.
- If both the supervisor and user passwords are set, users can enter either the supervisor password or the user password to access Setup. Users have access to Setup respective to which password is entered.
- Setting the user password restricts who can boot the computer. The password prompt will be displayed before the computer is booted. If only the supervisor password is set, the computer boots without asking for a password. If both passwords are set, the user can enter either password to boot the computer.
- For enhanced security, use different passwords for the supervisor and user passwords.
- Valid password characters are A-Z, a-z, and 0-9. Passwords may be up to 20 characters in length.
- To clear a set password, enter a blank password after entering the existing password.

Table 35 shows the effects of setting the supervisor password and user password. This table is for reference only and is not displayed on the screen.

Table 35. Supervisor and User Password Functions

Password Set	Supervisor Mode	User Mode	Setup Options	Password to Enter Setup	Password During Boot
Neither	Can change all options (Note)	Can change all options (Note)	None	None	None
Supervisor only	Can change all options	Can change a limited number of options	Supervisor Password	Supervisor	None
User only	N/A	Can change all options	Enter Password Clear User Password	User	User
Supervisor and user set	Can change all options	Can change a limited number of options	Supervisor Password Enter Password	Supervisor or user	Supervisor or user

Note: If no password is set, any user can change all Setup options.

4 Error Messages and Blink Codes

4.1 Front-panel Power LED Blink Codes

Whenever a recoverable error occurs during POST, the BIOS causes the board's front panel power LED to blink an error message describing the problem (see Table 36).

Table 36. Front-panel Power LED Blink Codes

Type	Pattern	Note
Power-on	Solid on primary color. Indicates S0 state.	Default to On; can be disabled via BIOS Setup
S3 Standby	Blink alternate color .25 seconds on, .25 seconds off, indefinitely. Indicates S3 state.	Default behavior; can be changed via BIOS Setup
Intel Ready Mode	Blink primary color, 1 second on, 1 second off, indefinitely.	
BIOS update in progress	Off when the update begins, then primary color on for 0.5 seconds, then off for 0.5 seconds. The pattern repeats until the BIOS update is complete.	
Memory error	On-off (1.0 second each) three times, then 2.5-second pause (off), entire pattern repeats (blinks and pause) until the system is powered off.	
Thermal trip warning	Blink primary color .25 seconds on, .25 seconds off, .25 seconds on, .25 seconds off. This will result in a total of 16 blinks (blink for 8 seconds).	

4.2 BIOS Error Messages

Table 30 lists the error messages and provides a brief description of each.

Table 30. BIOS Error Messages

Error Message	Explanation
CMOS Battery Low	The battery may be losing power. Replace the battery soon.
CMOS Checksum Bad	The CMOS checksum is incorrect. CMOS memory may have been corrupted. Run Setup to reset values.
Memory Size Decreased	Memory size has decreased since the last boot. If no memory was removed, then memory may be bad.
No Boot Device Available	System did not find a device to boot.

5 Intel NUC Kit Features

5.1 Chassis Front Panel Features

Intel NUC Board NUC7i3BNB board can be found integrated into Intel® NUC Kit NUC7i3BNH and Intel® NUC Kit NUC7i3BNK. Figure 22 and Figure 23 shows the location of the features located on or near the front of the chassis.

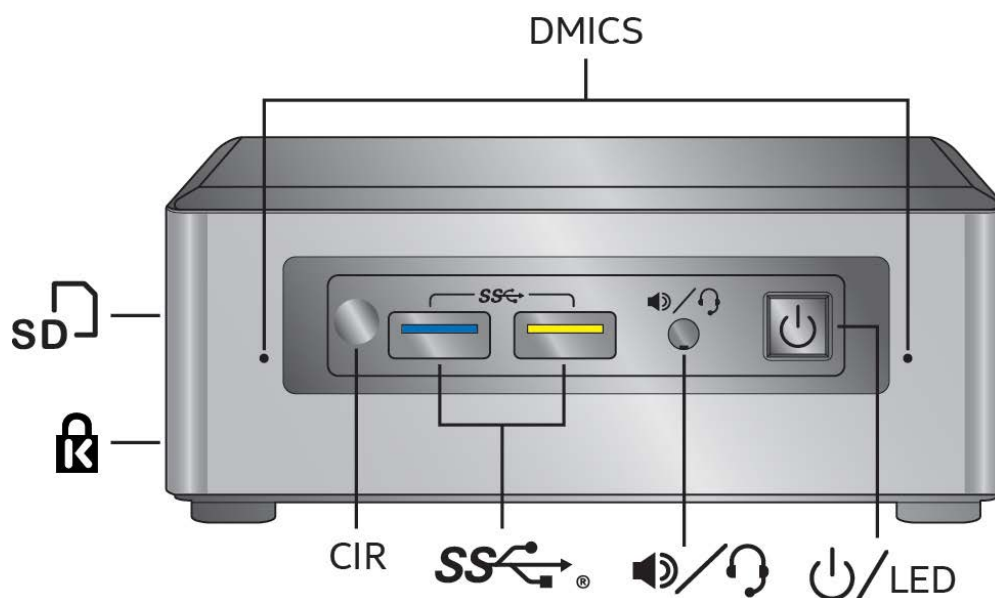

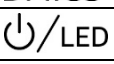
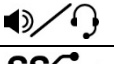
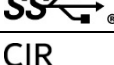

Figure 22. Intel NUC Kit NUC7i3BNH Features – Front

Table 37 lists the components identified in Figure 22.

Table 37. Components Shown in Figure 22

Item from Figure 22	Description
	Kensington* Anti-Theft Key Lock Hole
	Micro SDXC Card Reader
DMICS	Digital Microphone Array
	Power Switch and Power LED
	Speaker/Headset Jack
	USB 3.0 Connectors
CIR	Consumer Infrared Sensor

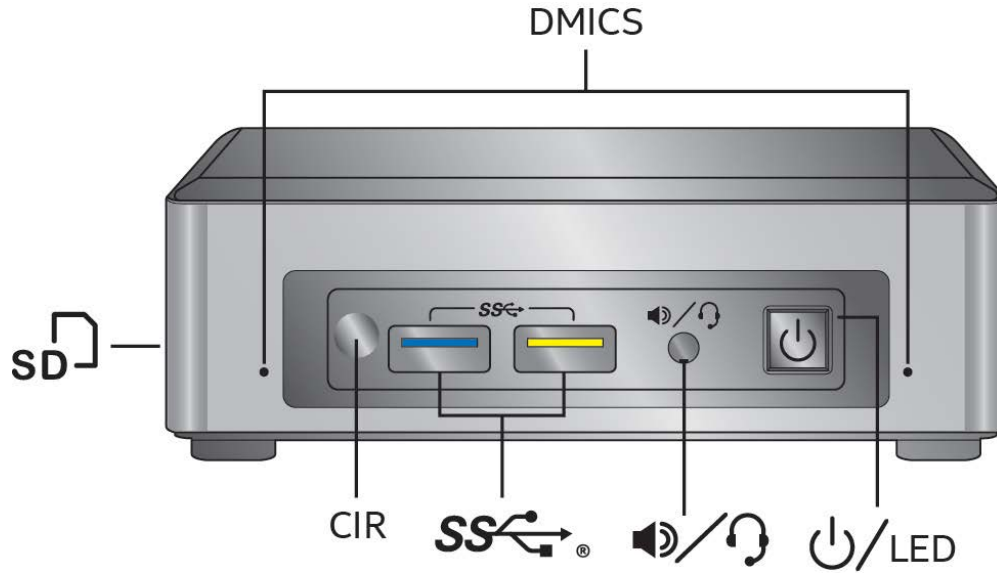

Figure 23. Intel NUC Kit NUC7i3BNK Features – Front

Table 38 lists the components identified in Figure 23.

Table 38. Components Shown in Figure 23

Item from Figure 23	Description
SD	Micro SDXC Card Reader
DMICS	Digital Microphone Array
power/LED	Power Switch and Power LED
Speaker/Headset Jack	Speaker/Headset Jack
SS	USB 3.0 Connectors
CIR	Consumer Infrared Sensor

5.3 Chassis Rear Panel Features

Figure 24 shows the location of the features located on the rear of the chassis.

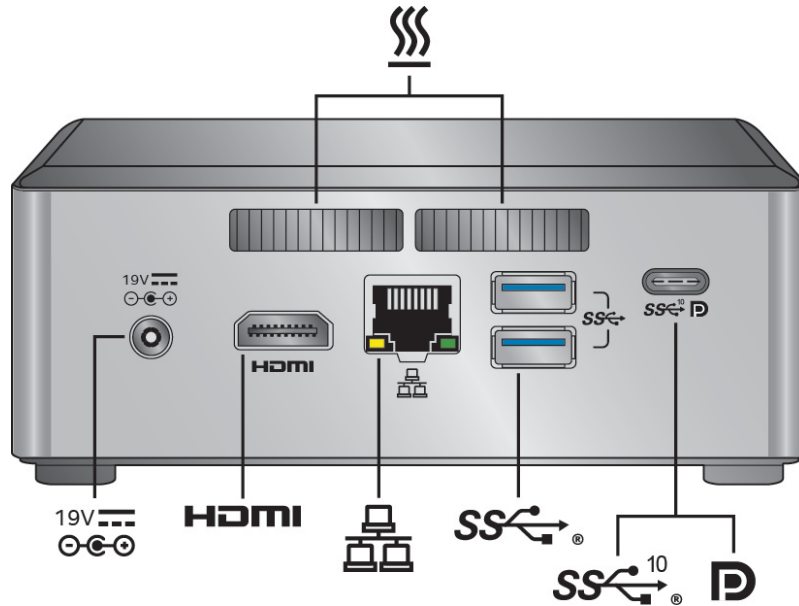

Figure 24. Intel NUC Kit NUC7i3BNH Features – Rear

Table 39 lists the components identified in Figure 24.

Table 39. Components Shown in Figure 24







Item from Figure 24	Description
 19V 	19V DC Power Inlet
	Cooling Vents
	DisplayPort via USB Type-C Connector
	USB 3.1 via USB Type-C Connector
	USB 3.0 Connectors
	Ethernet Port
HDMI	High Definition Multimedia Interface Connector

Figure 25 shows the location of the features located on the rear of the chassis.

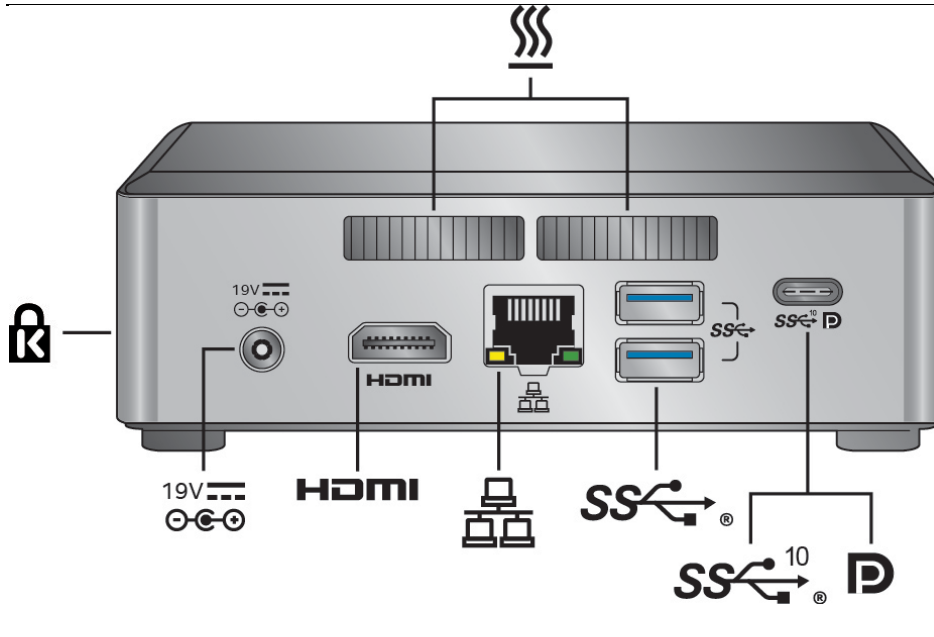









Figure 25. Intel NUC Kit NUC7i3BNK Features – Rear

Table 39 lists the components identified in Figure 25.

Table 40. Components Shown in Figure 25

Item from Figure 25	Description
	Kensington* Anti-Theft Key Lock Hole
	Cooling Vents
	DisplayPort via USB Type-C connector
	USB 3.1 via USB Type-C connector
	USB 3.0 Connectors
	Ethernet Port
	High Definition Multimedia Interface Connector
	19V DC Power Inlet

Mouser Electronics

Authorized Distributor

Click to View Pricing, Inventory, Delivery & Lifecycle Information:

[Intel:](#)

[BOXNUC7I3BNKL](#) [BOXNUC7I3BNH](#) [BOXNUC7I3BNHL](#) [BOXNUC7I3BNHX1](#) [BOXNUC7I3BNK](#)
[BOXNUC7I3BNHXFL](#) [BOXNUC7I3BNHXF](#) [BOXNUC7I3BNHX1L](#)



Компания «ЭлектроПласт» предлагает заключение долгосрочных отношений при поставках импортных электронных компонентов на взаимовыгодных условиях!

Наши преимущества:

- Оперативные поставки широкого спектра электронных компонентов отечественного и импортного производства напрямую от производителей и с крупнейших мировых складов;
- Поставка более 17-ти миллионов наименований электронных компонентов;
- Поставка сложных, дефицитных, либо снятых с производства позиций;
- Оперативные сроки поставки под заказ (от 5 рабочих дней);
- Экспресс доставка в любую точку России;
- Техническая поддержка проекта, помощь в подборе аналогов, поставка прототипов;
- Система менеджмента качества сертифицирована по Международному стандарту ISO 9001;
- Лицензия ФСБ на осуществление работ с использованием сведений, составляющих государственную тайну;
- Поставка специализированных компонентов (Xilinx, Altera, Analog Devices, Intersil, Interpoint, Microsemi, Aeroflex, Peregrine, Syfer, Eurofarad, Texas Instrument, Miteq, Cobham, E2V, MA-COM, Hittite, Mini-Circuits, General Dynamics и др.);

Помимо этого, одним из направлений компании «ЭлектроПласт» является направление «Источники питания». Мы предлагаем Вам помощь Конструкторского отдела:

- Подбор оптимального решения, техническое обоснование при выборе компонента;
- Подбор аналогов;
- Консультации по применению компонента;
- Поставка образцов и прототипов;
- Техническая поддержка проекта;
- Защита от снятия компонента с производства.



Как с нами связаться

Телефон: 8 (812) 309 58 32 (многоканальный)

Факс: 8 (812) 320-02-42

Электронная почта: org@eplast1.ru

Адрес: 198099, г. Санкт-Петербург, ул. Калинина, дом 2, корпус 4, литера А.