

Bus coupler - AXL F BK PB - 2688530

Please be informed that the data shown in this PDF Document is generated from our Online Catalog. Please find the complete data in the user's documentation. Our General Terms of Use for Downloads are valid (<http://phoenixcontact.com/download>)



Axioline F bus coupler for PROFIBUS DP (including bus base module and connector)

Product Description

The bus coupler represents the link between a PROFIBUS network and the Axioline F system. Up to 63 Axioline F devices can be connected at any point to an existing PROFIBUS network using the bus coupler.

Product Features

- Up to 63 additional Axioline devices can be connected
- D-SUB bus connection
- Electrical isolation between PROFIBUS interface and logic
- Rotary encoding switch
- DP/V1 for class 1 and class 2 masters
- PROFIBUS data transmission speed of 9.6 kbps to 12 Mbps
- Dynamic configuration is supported
- I&M functions
- Diagnostic and status indicators
- Firmware can be updated
- Typical cycle time of the Axioline F local bus is around 10 μ s



Key Commercial Data

Packing unit	1 pc
Weight per Piece (excluding packing)	220.0 g
Custom tariff number	85389091
Country of origin	Germany

Technical data

Dimensions

Width	45 mm
-------	-------

Bus coupler - AXL F BK PB - 2688530

Technical data

Dimensions

Height	125.9 mm
Depth	74 mm
Note on dimensions	The depth is valid when a TH 35-7.5 DIN rail is used (according to EN 60715).

Ambient conditions

Ambient temperature (operation)	-25 °C ... 60 °C (Mounting position: wall mounting on horizontal DIN rail)
	-25 °C ... 55 °C (Mounting position: any)
Ambient temperature (storage/transport)	-40 °C ... 85 °C
Permissible humidity (operation)	5 % ... 95 % (non-condensing)
Permissible humidity (storage/transport)	5 % ... 95 % (non-condensing)
Air pressure (operation)	70 kPa ... 106 kPa (up to 3000 m above sea level)
Air pressure (storage/transport)	70 kPa ... 106 kPa (up to 3000 m above sea level)
Degree of protection	IP20

Connection data

Designation	Axioline F connector
Connection method	Push-in connection
Note on connection method	Please observe the information provided on conductor cross sections in the "Axioline F: system and installation" user manual.
Conductor cross section solid min.	0.2 mm ²
Conductor cross section solid max.	1.5 mm ²
Conductor cross section flexible min.	0.2 mm ²
Conductor cross section flexible max.	1.5 mm ²
Conductor cross section AWG min.	24
Conductor cross section AWG max.	16
Stripping length	8 mm

General

Mounting type	DIN rail
Net weight	175 g
Note on weight specifications	with connector and bus base module
Diagnostics messages	Diagnostic alarms

Interfaces

Fieldbus system	PROFIBUS DP
Designation	PROFIBUS DP
Connection method	D-SUB-9 female connector
Transmission speed	9,6 kBit/s ... 12 MBit/s
Number of positions	9

Bus coupler - AXL F BK PB - 2688530

Technical data

Interfaces

Fieldbus system	Lokalbus
Designation	Axioline F local bus
Connection method	Bus base module
Transmission speed	100 MBit/s
Designation	Service
Connection method	Micro USB type B

System limits of the bus coupler

Designation	System limits of the bus coupler
Amount of process data	max. 488 Byte (per station)
	max. 244 Byte (Input)
	max. 244 Byte (Output)
Number of parameter data	max. 244 Byte
Number of configuration data	max. 244 Byte
Number of supported devices	max. 63 (per station)
Number of local bus devices that can be connected	max. 63

Axioline potentials

Supply of communications power U_L	24 V DC
Current consumption from U_L	typ. 101 mA (without I/Os and $U_L = 24$ V)
	max. 567 mA (with 2 A at U_{Bus} for the I/Os and $U_L = 24$ V)
Communications power U_{Bus}	5 V DC (via bus base module)
Current supply at U_{Bus}	2 A

Standards and Regulations

Conformity with EMC directives	Noise immunity test in accordance with EN 61000-6-2 Electrostatic discharge (ESD) EN 61000-4-2/IEC 61000-4-2 Criterion B, 6 kV contact discharge, 8 kV air discharge
	Noise immunity test in accordance with EN 61000-6-2 Electromagnetic fields EN 61000-4-3/IEC 61000-4-3 Criterion A, Field intensity: 10 V/m
	Noise immunity test in accordance with EN 61000-6-2 Fast transients (burst) EN 61000-4-4/IEC 61000-4-4 Criterion B, 2 kV
	Noise immunity test in accordance with EN 61000-6-2 Transient overvoltage (surge) EN 61000-4-5/IEC 61000-4-5 Criterion B, DC supply lines: ± 0.5 kV/ ± 0.5 kV (symmetrical/asymmetrical), fieldbus cable shield: ± 1 kV
	Noise immunity test in accordance with EN 61000-6-2 Conducted interference EN 61000-4-6/IEC 61000-4-6 Criterion A; Test voltage 10 V
	Noise emission test according to EN 61000-6-3 Radio interference properties EN 55022 Class B
Mechanical tests	Vibration resistance in acc. with EN 60068-2-6/IEC 60068-2-6 5g

Bus coupler - AXL F BK PB - 2688530

Technical data

Standards and Regulations

	Shock in acc. with EN 60068-2-27/IEC 60068-2-27 30g, 11 ms period, half-sine shock pulse
	Continuous shock according to EN 60068-2-27/IEC 60068-2-27 10g
Protection class	III, IEC 61140, EN 61140, VDE 0140-1

Classifications

eCl@ss

eCl@ss 4.0	27240490
eCl@ss 4.1	27240490
eCl@ss 5.0	27242208
eCl@ss 5.1	27242608
eCl@ss 6.0	27242608
eCl@ss 7.0	27242608
eCl@ss 8.0	27242608
eCl@ss 9.0	27242608

ETIM

ETIM 3.0	EC001604
ETIM 4.0	EC001604
ETIM 5.0	EC001604

UNSPSC

UNSPSC 6.01	43172015
UNSPSC 7.0901	43201404
UNSPSC 11	39121311
UNSPSC 12.01	39121311
UNSPSC 13.2	39121311

Approvals

Approvals

Approvals

UL Listed / cUL Listed / EAC / PROFIBUS / cULus Listed

Ex Approvals

Bus coupler - AXL F BK PB - 2688530

Approvals

Approvals submitted

Approval details

UL Listed

cUL Listed

EAC

PROFIBUS

cULus Listed

Accessories

Accessories

Data plug

D-SUB bus connector - SUBCON-PLUS-PROFIB/35/M12 - 2902320



D-SUB plug, 9-pos., pin, assignment: 3, 5, 6, 8; two M12 cable glands (B-coded) under 35°. Bus system: PROFIBUS DP up to 12 Mbps. Termination resistor via separate M12 terminator.

D-SUB bus connector - SUBCON-PLUS-PROFIB/SC2 - 2708232



D-SUB connector, 9-pos., male connector, cable entry < 35°, bus system: PROFIBUS DP up to 12 Mbps, termination resistor can be switched on via slide switch, pin assignment: 3, 5, 6, 8; screw connection terminal blocks

Bus coupler - AXL F BK PB - 2688530

Accessories

D-SUB bus connector - SUBCON-PLUS-PROFIB/90/IDC - 2313672



D-SUB connector, 9-pos., male connector, cable entry < 90°, bus system: PROFIBUS DP up to 12 Mbps, termination resistor can be switched on via slide switch, pin assignment: 3, 5, 6, 8; IDC terminal block connection

D-SUB bus connector - SUBCON-PLUS-PROFIB/90/SC - 2313698



D-SUB connector, 9-pos., male connector, cable entry < 90°, bus system: PROFIBUS DP up to 12 Mbps, termination resistor can be switched on via slide switch, pin assignment: 3, 5, 6, 8; screw connection terminal blocks

D-SUB bus connector - SUBCON-PLUS-PROFIB/AX/SC - 2744380



D-SUB connector, 9-pos., male connector, axial version with two cable entries, bus system: PROFIBUS DP up to 12 Mbps, termination resistor can be switched on via slide switch, pin assignment: 3, 5, 6, 8; screw connection terminal blocks

Device marking

Insert label - EMT (35X18,7)R - 0801831



Insert label, Roll, white, unlabeled, can be labeled with: THERMOMARK ROLL, THERMOMARK ROLL X1, THERMOMARK X, THERMOMARK S1.1, Mounting type: snapped into marker carrier, Lettering field: 35 x 18.7 mm

DIN rail connector

Bus coupler - AXL F BK PB - 2688530

Accessories

Bus connector - AXL BS BK - 2701422



Axioline F bus base module for housing type BK

Plug

Plug - AXL CN S/UL - 2701421



Axioline F short power connector (for e.g., AXL F BK ...)

Programming cable

Connecting cable - CAB-USB A/MICRO USB B/2,0M - 2701626



Connecting cable, for connecting the controller to a PC for PC Worx and LOGIC+, USB A to micro USB B, 2 m in length.

Terminal marking

Zack marker strip - ZB 20,3 AXL UNPRINTED - 0829579



Zack marker strip for Axioline F (device labeling), in 2 x 20.3 mm pitch, unprinted, 25-section, for individual labeling with B-STIFT 0.8, X-PEN, or CMS-P1-PLOTTER

Bus coupler - AXL F BK PB - 2688530

Accessories

Zack Marker strip, flat - ZBF 10/5,8 AXL UNPRINTED - 0829580



Zack marker strip, flat, in 10 mm pitch, unprinted, 10-section, for individual labeling with M-PEN 0,8, X-PEN, or CMS-P1-PLOTTER

Drawings

Connection diagram

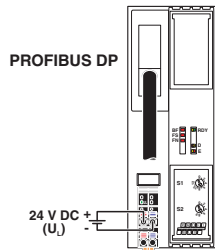

Block diagram

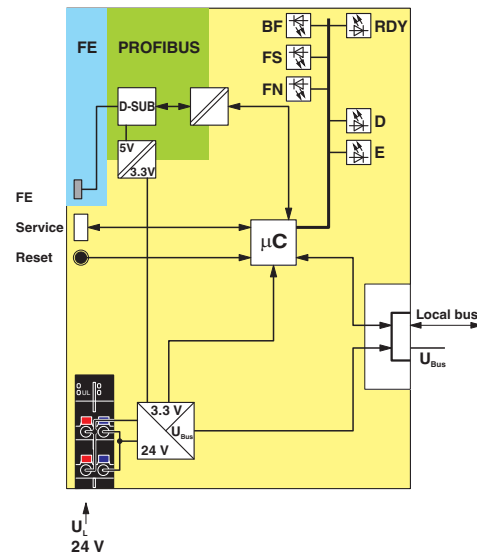

Internal wiring of the terminal points

Dimensional drawing

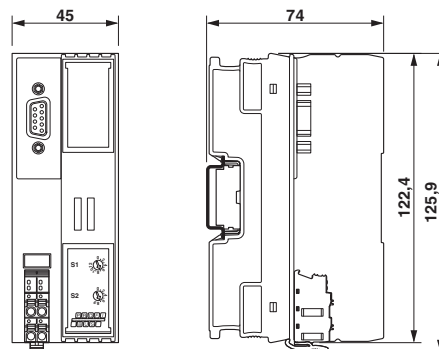



Компания «ЭлектроПласт» предлагает заключение долгосрочных отношений при поставках импортных электронных компонентов на взаимовыгодных условиях!

Наши преимущества:

- Оперативные поставки широкого спектра электронных компонентов отечественного и импортного производства напрямую от производителей и с крупнейших мировых складов;
- Поставка более 17-ти миллионов наименований электронных компонентов;
- Поставка сложных, дефицитных, либо снятых с производства позиций;
- Оперативные сроки поставки под заказ (от 5 рабочих дней);
- Экспресс доставка в любую точку России;
- Техническая поддержка проекта, помощь в подборе аналогов, поставка прототипов;
- Система менеджмента качества сертифицирована по Международному стандарту ISO 9001;
- Лицензия ФСБ на осуществление работ с использованием сведений, составляющих государственную тайну;
- Поставка специализированных компонентов (Xilinx, Altera, Analog Devices, Intersil, Interpoint, Microsemi, Aeroflex, Peregrine, Syfer, Eurofarad, Texas Instrument, Miteq, Cobham, E2V, MA-COM, Hittite, Mini-Circuits, General Dynamics и др.);

Помимо этого, одним из направлений компании «ЭлектроПласт» является направление «Источники питания». Мы предлагаем Вам помощь Конструкторского отдела:

- Подбор оптимального решения, техническое обоснование при выборе компонента;
- Подбор аналогов;
- Консультации по применению компонента;
- Поставка образцов и прототипов;
- Техническая поддержка проекта;
- Защита от снятия компонента с производства.



Как с нами связаться

Телефон: 8 (812) 309 58 32 (многоканальный)

Факс: 8 (812) 320-02-42

Электронная почта: org@eplast1.ru

Адрес: 198099, г. Санкт-Петербург, ул. Калинина, дом 2, корпус 4, литера А.