

### SOP-8EP

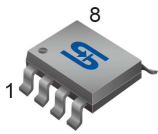

### Pin Definition:

- |          |         |
|----------|---------|
| 1. EN/SS | 8. COMP |
| 2. GND   | 7. FB   |
| 3. VGATE | 6. OVP  |
| 4. Vcc   | 5. SW   |

## General Description

The TS19378 is a high voltage step-down converter designed for driving up to 10 series white LEDs from a 40V system input. The total LED driving current up to 2A, which is measured through an external current sense resistor. Its low 200mV feedback voltage reduces power loss and improves efficiency. The OVP pin monitors the output voltage and turns off the converter if an over-voltage condition is present due to an open circuit condition. The TS19378 includes current limit, short circuit protection and thermal shutdown protection preventing damage. TS19378 provides high power, high efficiency, and excellent transient characteristics. The PWM control circuit is able to the duty ratio linearly from 0 up to 100%. Since this converter can accommodate an input voltage up to 40V, it is also suitable for the operation via an AC adapter.

## Features

- Input Voltage Range 8V~40V
- Output voltage up to 38V
- 2A Switch Output Current
- Duty ratio: 0%~100% PWM control
- 300kHz Switching Frequency
- Enable/Disable Functions
- Soft Start Time Control
- Current limit and Thermal Shutdown
- Short Circuit Protections
- Built-in Internal SW P-CH MOS

## Application

- White LED Backlighting
- High Power LED Application
- Multiple LED Driving
- LED Lighting Equipment

## Ordering Information

Part No.	Package	Packing
TS19378CS RLG	SOP-8EP	2.5Kpcs / 13" Reel

**Note:** "G" denotes Halogen Free Product.

## Block Diagram

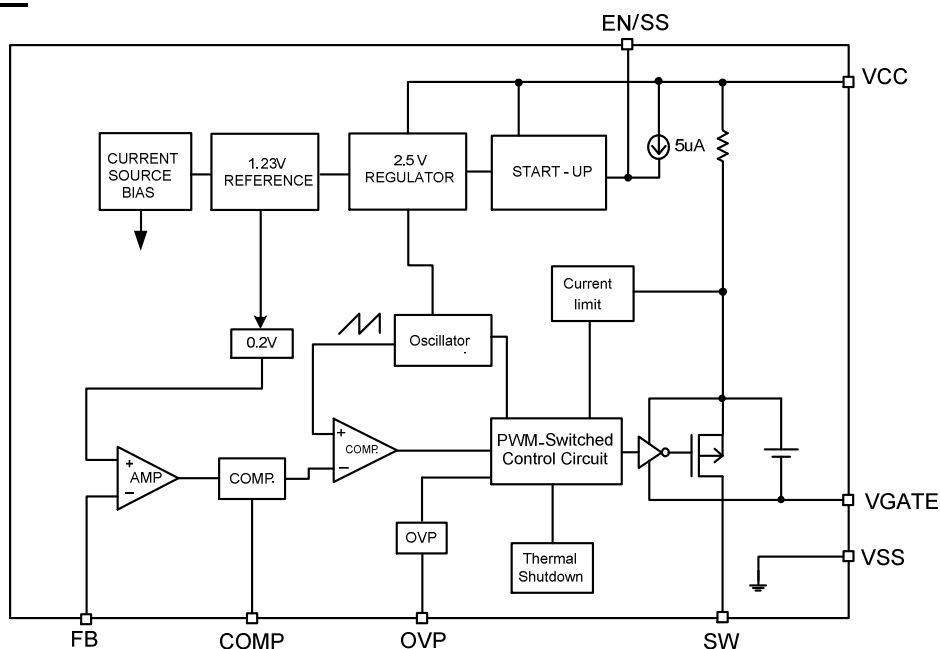

**Absolute Maximum Rating**

Parameter	Symbol	Limit	Unit
V <sub>CC</sub> Pin Voltage	V <sub>CC</sub>	V <sub>SS</sub> - 0.3 to V <sub>SS</sub> + 45	V
Feedback Pin Voltage	V <sub>FB</sub>	V <sub>SS</sub> - 0.3 to 6	V
EN/SS Pin Voltage	V <sub>EN/SS</sub>	V <sub>SS</sub> - 0.3 to 6	V
OVP Pin Voltage	V <sub>OVP</sub>	V <sub>SS</sub> - 0.3 to V <sub>CC</sub>	V
COMP Pin Voltage	V <sub>COMP</sub>	V <sub>SS</sub> - 0.3 to 6	V
VGATE Pin Voltage	V <sub>GATE</sub>	V <sub>SS</sub> - 0.3 to V <sub>CC</sub>	V
Switch Pin Voltage	V <sub>SW</sub>	V <sub>SS</sub> - 0.3 to V <sub>CC</sub> + 0.3	V
Power Dissipation	PD	Internally limited	mW
Storage Temperature Range	T <sub>ST</sub>	-65 to +150	°C
Operating Junction Temperature Range	T <sub>OJP</sub>	-40 to +125	°C
Operating Supply Voltage	V <sub>OP</sub>	8 to 40	V
Output Voltage	V <sub>OUT</sub>	38	V
Thermal Resistance from Junction to case	θ <sub>JC</sub>	15	°C/W
Thermal Resistance from Junction to ambient	θ <sub>JA</sub>	40	°C/W

Note: θ<sub>JA</sub> is measured with the PCB copper area(need connect to Exposed Pad) of approximately 1.5 in<sup>2</sup>(Multi-layer).

**Electrical Specifications** (V<sub>IN</sub>=12V, T<sub>A</sub> =25°C, unless otherwise noted)

Parameter	Symbol	Conditions	Min	Typ	Max	Units
Feedback Voltage	V <sub>FB</sub>	I <sub>OUT</sub> =0.2A	0.19	0.20	0.21	V
Quiescent Current	I <sub>CCQ</sub>	V <sub>FB</sub> =0.5V force driver off	--	3	6	mA
Feedback Bias Current	I <sub>FB</sub>	I <sub>OUT</sub> =0.1A	--	0.1	0.5	uA
Shutdown Supply Current	I <sub>SD</sub>	V <sub>EN</sub> =0V	--	150	300	uA
Switch Current Limit	I <sub>SWLIMIT</sub>		2.5	--	--	A
Oscillation Frequency	F <sub>OSC</sub>		240	300	360	KHz
Short Frequency	F <sub>OSC</sub>		--	50	--	KHz
EN/SS Pin Shutdown Logic input threshold voltage	V <sub>SL</sub>	Low (regulator OFF)	--	--	0.8	V
EN/SS Pin Input Current	I <sub>EN/SS</sub>	V <sub>EN</sub> =0V	--	5	--	uA
Internal MOSFET R <sub>DS(ON)</sub>	R <sub>DS(ON)</sub>	V <sub>CC</sub> =5V, V <sub>FB</sub> =0V	--	130	180	mΩ
OVP Sense Voltage	V <sub>OVP</sub>		0.833	0.850	0.867	V
Thermal shutdown Temp	T <sub>SD</sub>		--	150	--	°C
Thermal shutdown Hysteresis	T <sub>SH</sub>		--	40	--	°C

**Typical Application Circuit**

**A: Normal Application Circuit**

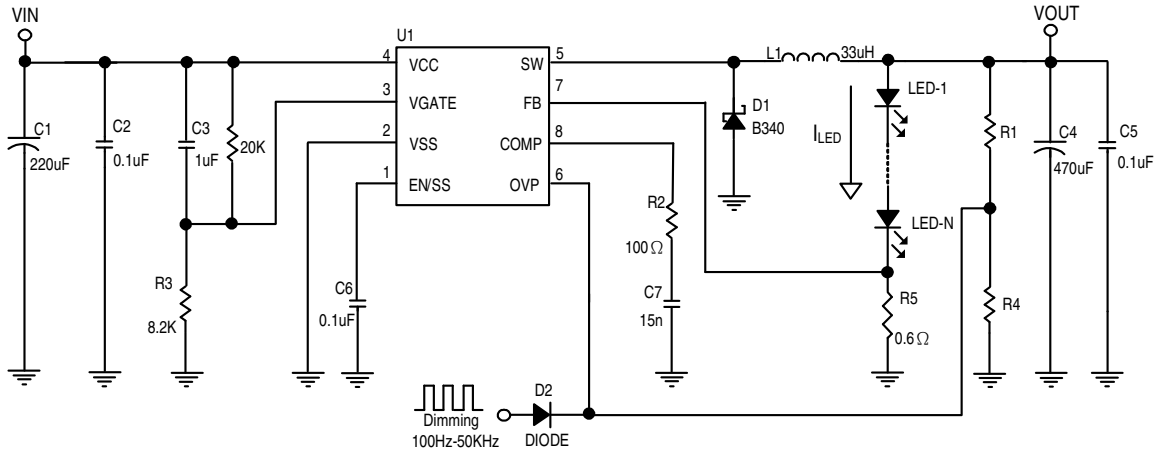

$V_{FB} = 0.2V$   
 $I_{LED} = V_{FB}/R5$   
 $V_{OVP} (OVP) = 0.85 \times (1 + \frac{R1}{R4})$

C <sub>OUT</sub> ESR Range	R2	C7
30~80mΩ	470R	10nF
80~300mΩ	100R	15nF

**B: AC Input Application Circuit (Inverting)**

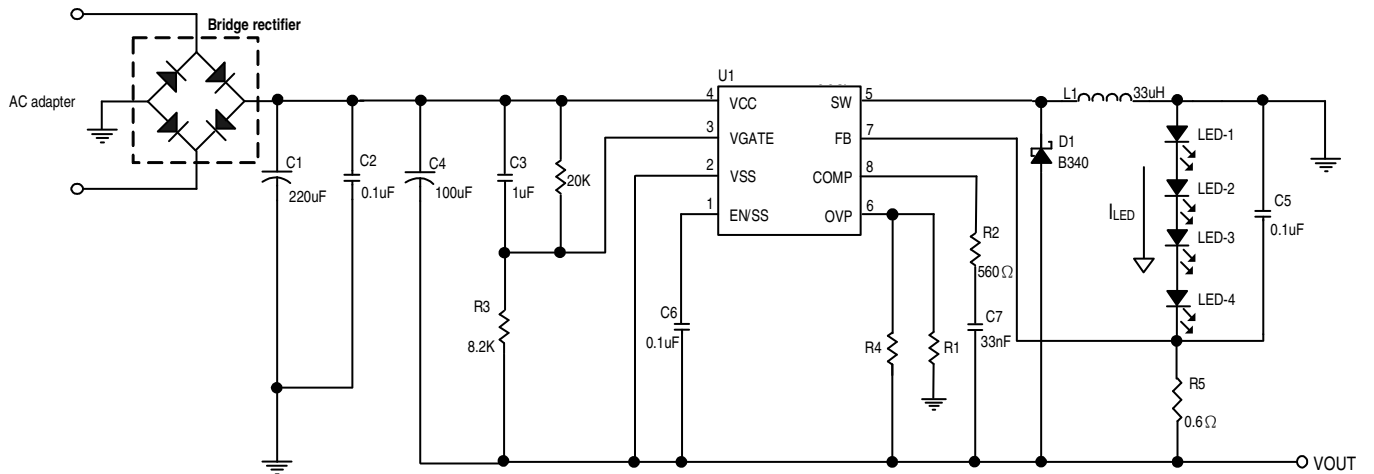

$V_{FB} = 0.2V$   
 $I_{LED} = V_{FB}/R5$   
 $V_{OVP} (OVP) = 0.85 \times (1 + \frac{R1}{R4})$

I <sub>LED</sub>	R5	C1	L1
350mA	0.57Ω	70mW	33uH
750mA	0.266Ω	150mW	
1000mA	0.2Ω	200mW	



### Function Descriptions

#### PWM Control

The TS19378 consists of DC/DC converters that employ a pulse-width modulation (PWM) system. In converters of the TS19378, the pulse width varies in a range from 0 to 100%, according to the load current. The ripple voltage produced by the switching can easily be removed through a filter because the switching frequency remains constant. Therefore, these converters provide a low-ripple power over broad ranges of input voltage and load current

#### Setting I<sub>LED</sub> Current

Application circuit item shows the basic application circuit with TS19378 adjustable output version. The external resistor sets the LED output current according to the following formula:

$$I_{LED} = (0.25V/R5), V_{FB} = 0.2V$$

Resistor select for LED output current setting

I <sub>LED</sub>	R2	
350mA	0.57Ω	70mW
750mA	0.266Ω	150mW
1000mA	0.2Ω	200mW

#### Current Liming

The current limit threshold is setting by the internal circuit.

#### Compensation

In all LED driver applications. Connecting a resistor (R2) and a capacitor (C7) from COMP pin to GND. Please refer the application circuit table to design.

#### EN/SS

This pin can be supplied shutdown or soft start function. It is inside pull high function. For normal application, the pin must be connected a capacitor to ground. There is a 5uA current to charge this capacitor, vary the different capacitor value to control soft start time. Allow the switching regulator circuit to be shutdown pulling this pin below a 0.8V threshold voltage; the shutdown supply current is approximately 150uA

#### Inductor Selection

For most designs, the different frequency can be reducing the inductor value; The TS19378 is suggested 33uH. Where is inductor Ripple Current. Large value inductors lower ripple current and small value inductors result in high ripple currents. Choose inductor ripple current approximately 20% of the maximum load current 2A,  $\Delta I_L = 0.4A$ . The DC current rating of the inductor should be at least equal to the maximum load current plus half the ripple current to prevent core saturation (2A+0.2A).

#### Input Capacitor Selection

This capacitor should be located close to the IC using short leads and the voltage rating should be approximately 1.5 times the maximum input voltage. The RMS current rating requirement for the input capacitor of a buck regulator is approximately 1/2 the DC load current. A low ESR input capacitor sized for maximum RMS current must be used. A 220μF low ESR capacitor for most applications is sufficient.

#### Over Voltage Protection

The OVP voltage is set by outside resistance (R1 and R4). The external resistor sets the OVP voltage according to the following equation:

$$V_{OUT}(OVP) = V_{OVP} \times \left(1 + \frac{R4}{R1}\right)$$

If  $V_{OVP} > 0.85V$ , The OVP is happened that to disable the driver until  $V_{OVP} < 0.85V$ .

**Function Descriptions (Continue)****Output Capacitor Selection**

For lower output voltage ripple and more stable LED current, higher value output capacitor and low ESR is recommended. A 470uF electrolytic capacitor works for most of the applications.

**SOP-8EP Mechanical Drawing**

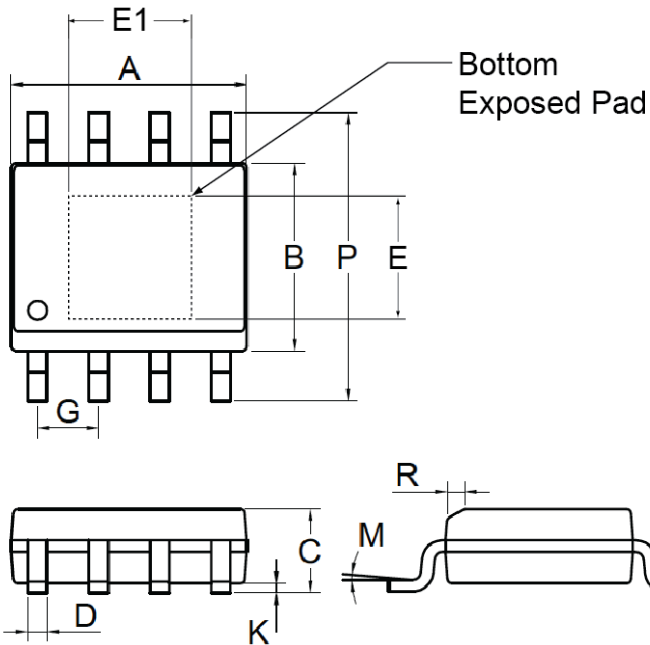

SOP-8EP DIMENSION				
DIM	MILLIMETERS		INCHES	
	MIN	MAX	MIN	MAX.
A	4.80	5.00	0.189	0.196
B	3.80	4.00	0.150	0.157
C	1.35	1.75	0.054	0.068
D	0.35	0.49	0.014	0.019
E	2.05	2.41	0.081	0.095
E1	2.82	3.30	0.111	0.130
F	0.40	1.25	0.016	0.049
G	1.27BSC		0.05BSC	
K	0.10	0.25	0.004	0.009
M	0°	7°	0°	7°
P	5.80	6.20	0.229	0.244
R	0.25	0.50	0.010	0.019

**Marking Diagram**

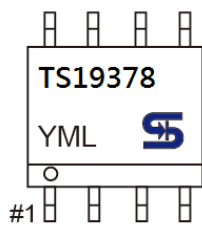

- Y** = Year Code
- M** = Month Code for Halogen Free Product  
(**O**=Jan, **P**=Feb, **Q**=Mar, **R**=Apr, **S**=May, **T**=Jun, **U**=Jul, **V**=Aug, **W**=Sep, **X**=Oct, **Y**=Nov, **Z**=Dec)
- L** = Lot Code

### Notice

Specifications of the products displayed herein are subject to change without notice. TSC or anyone on its behalf, assumes no responsibility or liability for any errors or inaccuracies.

Information contained herein is intended to provide a product description only. No license, express or implied, to any intellectual property rights is granted by this document. Except as provided in TSC's terms and conditions of sale for such products, TSC assumes no liability whatsoever, and disclaims any express or implied warranty, relating to sale and/or use of TSC products including liability or warranties relating to fitness for a particular purpose, merchantability, or infringement of any patent, copyright, or other intellectual property right.

The products shown herein are not designed for use in medical, life-saving, or life-sustaining applications. Customers using or selling these products for use in such applications do so at their own risk and agree to fully indemnify TSC for any damages resulting from such improper use or sale.



Компания «ЭлектроПласт» предлагает заключение долгосрочных отношений при поставках импортных электронных компонентов на взаимовыгодных условиях!

Наши преимущества:

- Оперативные поставки широкого спектра электронных компонентов отечественного и импортного производства напрямую от производителей и с крупнейших мировых складов;
- Поставка более 17-ти миллионов наименований электронных компонентов;
- Поставка сложных, дефицитных, либо снятых с производства позиций;
- Оперативные сроки поставки под заказ (от 5 рабочих дней);
- Экспресс доставка в любую точку России;
- Техническая поддержка проекта, помощь в подборе аналогов, поставка прототипов;
- Система менеджмента качества сертифицирована по Международному стандарту ISO 9001;
- Лицензия ФСБ на осуществление работ с использованием сведений, составляющих государственную тайну;
- Поставка специализированных компонентов (Xilinx, Altera, Analog Devices, Intersil, Interpoint, Microsemi, Aeroflex, Peregrine, Syfer, Eurofarad, Texas Instrument, Miteq, Cobham, E2V, MA-COM, Hittite, Mini-Circuits, General Dynamics и др.);

Помимо этого, одним из направлений компании «ЭлектроПласт» является направление «Источники питания». Мы предлагаем Вам помощь Конструкторского отдела:

- Подбор оптимального решения, техническое обоснование при выборе компонента;
- Подбор аналогов;
- Консультации по применению компонента;
- Поставка образцов и прототипов;
- Техническая поддержка проекта;
- Защита от снятия компонента с производства.



#### Как с нами связаться

**Телефон:** 8 (812) 309 58 32 (многоканальный)

**Факс:** 8 (812) 320-02-42

**Электронная почта:** [org@eplast1.ru](mailto:org@eplast1.ru)

**Адрес:** 198099, г. Санкт-Петербург, ул. Калинина, дом 2, корпус 4, литера А.