

CR Series Round Single Pole Specialty Rocker Switches

Features/Benefits

- Round actuator and body
- Nice styling
- Multiple illuminated versions available
- IP65 splash proof rubber boot option

Typical Applications

- Appliances, small and large
- Office equipment
- Computers and peripherals
- Audio/Video equipment
- RoHS compliant



UL US UL 61058-1

Specifications

CONTACT RATING:

16 AMPS @ 125 VAC, 10 AMPS @ 250 VAC.

16 AMPS @ 125 VAC, 10 AMPS @ 250 VAC.

ELECTRICAL LIFE: 10,000 make and break cycles at full load.

INSULATION RESISTANCE: $10^8 \Omega$ min.

DIELECTRIC STRENGTH: 1,500 VRMS @ sea level.

OPERATING TEMPERATURE: -20°C to + 85°C

Materials

HOUSING AND ACTUATOR: 6/6 nylon (UL94V-2), matte finish.

ILLUMINATED ACTUATOR: Polycarbonate, matte finish.

CENTER CONTACTS: Silver plated, copper alloy.

END CONTACTS: Silver plated $AgSnO_2InO_3$.

ALL TERMINALS: Silver plated, copper alloy.

NOTE: Specifications and materials listed above are for switches with standard options. For information on specific and custom switches, consult Customer Service Center.

Build-A-Switch

To order, simply select desired option from each category and place in the appropriate box. Available options are shown and described on pages G-78 through G-80. For additional options not shown in catalog, consult Customer Service Center.

Switch Function	_____								
CR101	SPDT On-None-On								
CR102	SPST On-None-Off								
Actuator	_____								
J1	Rocker								
J2*	Two-tone rocker								
J3	Illuminated rocker								
J4**	Circle, illuminated rocker								
J5	Oval, illuminated rocker								
JN	Paddle, rocker								
JP	Paddle, illuminated rocker								
Actuator Color	_____								
2	Black								
1	White								
3	Red								
R	Red, illuminated								
A	Amber, illuminated								
G	Green, illuminated								
Mounting Style/Color	_____								
S2	Snap-in, black								
S1	Snap-in, white								
Termination	_____								
15	.187" quick connect								
Contact Rating	_____								
QF	Silver								
Lamp Rating	_____								
(NONE)	No lamp								
6	LED								
7	125 VAC neon								
8	250 VAC neon								

* Refer to table on page G-79 for actuator options.

CR Series Round Single Pole Specialty Rocker Switches

SWITCH FUNCTION



NO. POLES	MODEL NO.	SWITCH FUNCTION			CONNECTED TERMINALS			SCHEMATIC
		Pos. 1	Pos. 2	Pos. 3	Pos. 1	Pos. 2	Pos. 3	
	CR101	ON	NONE	ON	2-3		2-1	
SP	CR102	ON	NONE	OFF		N/A		<p>OR</p> <p>For 7 & 8 Illuminated Versions</p>

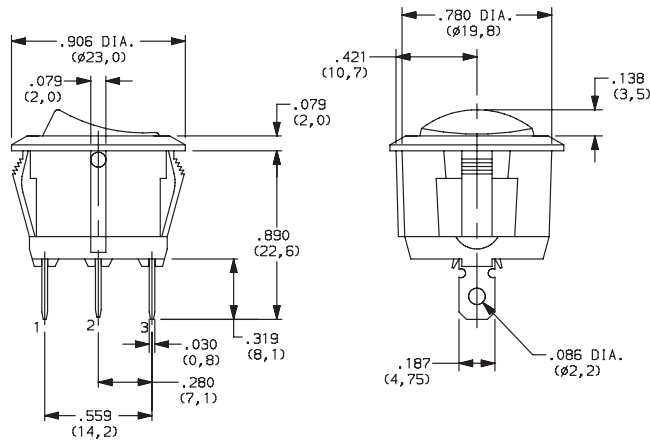

ACTUATOR



- J1** ROCKER
- J3** ILLUMINATED ROCKER

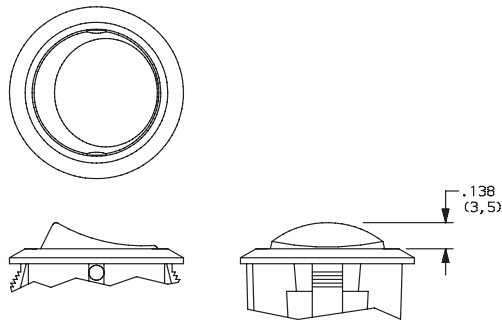

- J2** TWO-TONE ROCKER

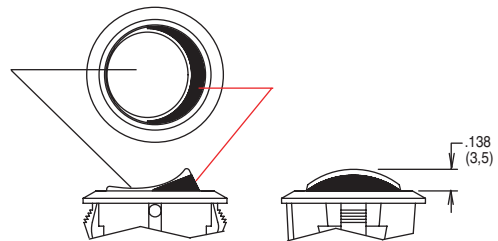

NOTE: J3 actuator available with the combination of 7 & 8 lamp ratings and CR102 switch function only.



Dimensions are shown: Inches (mm)
Specifications and dimensions subject to change



Round Single Pole Specialty Rocker Switches

ACTUATOR



J4 CIRCLE, ILLUMINATED ROCKER

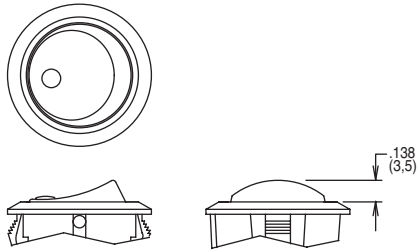

NOTE: Available with the combination of CR102 switch function and 7 & 8 lamp ratings only.

J5 OVAL, ILLUMINATED ROCKER

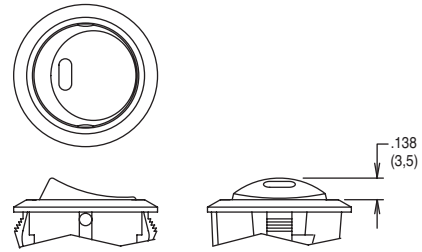

NOTE: Available with the combination of CR102 switch function and 6 lamp rating only.

JN PADDLE, ROCKER

JP PADDLE, ILLUMINATED ROCKER

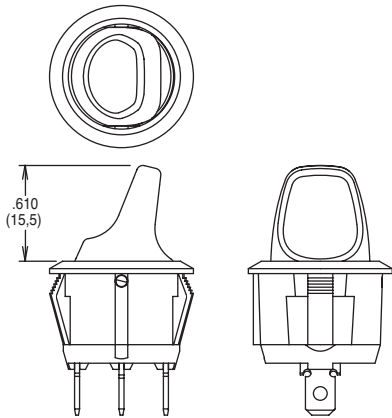

NOTE: JP actuator available with the combination of CR102 switch function and 7 & 8 lamp ratings only.

ACTUATOR COLOR



ACTUATOR	OPTION CODE	ACTUATOR COLOR
J1	2	BLACK
	1	WHITE
	3	RED
J3, J4, J5, JP	R	RED, ILLUMINATED
	A	AMBER, ILLUMINATED
	G	GREEN, ILLUMINATED

ACTUATOR	OPTION CODE	ACTUATOR COLOR	
		TOP	BOTTOM
J2	1	WHITE	RED
	2	WHITE	BLACK
	3	RED	WHITE
	4	BLACK	WHITE
	5	BLACK	RED

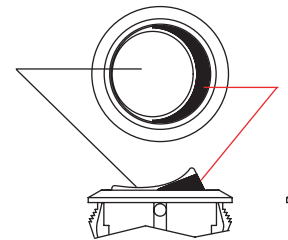

J2 actuator only

MOUNTING STYLE/COLOR



S2 SNAP-IN, BLACK

S1 SNAP-IN, WHITE

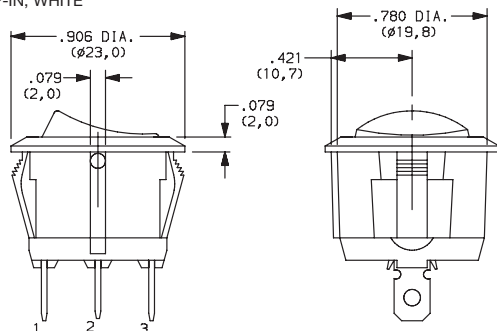

PANEL MOUNTING

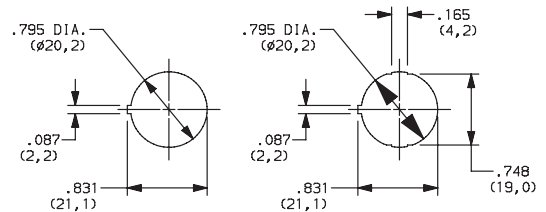

Panel thickness:
2.0 - 3.0 mm

Panel thickness:
0.7 - 3.0 mm



Dimensions are shown: Inches (mm)

Specifications and dimensions subject to change

CR Series Round Single Pole Specialty Rocker Switches

TERMINATION



15 .187" QUICK CONNECT

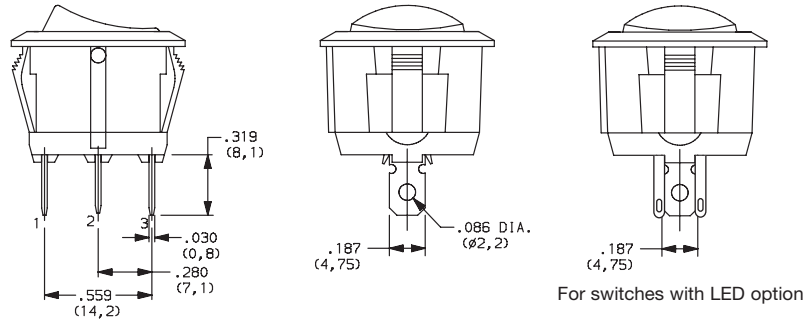

CONTACT MATERIAL



OPTION CODE	CONTACT AND TERMINAL MATERIAL	RATINGS	
		QF	SILVER

* Note: See Technical Data section of this catalog for RoHS compliant and compatible definitions and specifications.

LAMP RATING



(NONE) NO LAMP

6 LED RATING @ 10 mA $V_f=1.85V$

7 125 VAC 33kΩ NEON

8 250 VAC 150kΩ NEON

ACCESSORIES

377C00000 IP65 SPLASH PROOF RUBBER BOOT

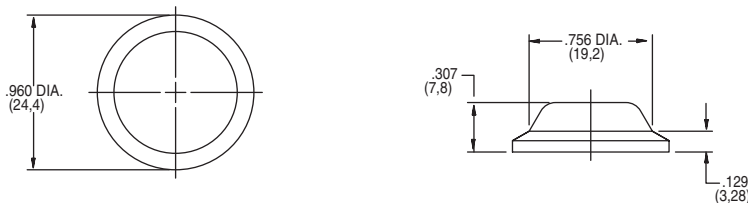

Dimensions are shown: Inches (mm)
Specifications and dimensions subject to change





Компания «ЭлектроПласт» предлагает заключение долгосрочных отношений при поставках импортных электронных компонентов на взаимовыгодных условиях!

Наши преимущества:

- Оперативные поставки широкого спектра электронных компонентов отечественного и импортного производства напрямую от производителей и с крупнейших мировых складов;
- Поставка более 17-ти миллионов наименований электронных компонентов;
- Поставка сложных, дефицитных, либо снятых с производства позиций;
- Оперативные сроки поставки под заказ (от 5 рабочих дней);
- Экспресс доставка в любую точку России;
- Техническая поддержка проекта, помощь в подборе аналогов, поставка прототипов;
- Система менеджмента качества сертифицирована по Международному стандарту ISO 9001;
- Лицензия ФСБ на осуществление работ с использованием сведений, составляющих государственную тайну;
- Поставка специализированных компонентов (Xilinx, Altera, Analog Devices, Intersil, Interpoint, Microsemi, Aeroflex, Peregrine, Syfer, Eurofarad, Texas Instrument, Miteq, Cobham, E2V, MA-COM, Hittite, Mini-Circuits, General Dynamics и др.);

Помимо этого, одним из направлений компании «ЭлектроПласт» является направление «Источники питания». Мы предлагаем Вам помощь Конструкторского отдела:

- Подбор оптимального решения, техническое обоснование при выборе компонента;
- Подбор аналогов;
- Консультации по применению компонента;
- Поставка образцов и прототипов;
- Техническая поддержка проекта;
- Защита от снятия компонента с производства.



Как с нами связаться

Телефон: 8 (812) 309 58 32 (многоканальный)

Факс: 8 (812) 320-02-42

Электронная почта: org@eplast1.ru

Адрес: 198099, г. Санкт-Петербург, ул. Калинина, дом 2, корпус 4, литера А.