

3M™ 4-Wall, Tripolarized Header

.050" × .100" Latch/Ejector, Right Angle, 4 Rows of Solder Tails

810 Series



- Tripolarization to mating socket
- 50 mil × 100 mil halves the connector length
- Latch and eject for rugged high performance applications
- 4 row tail design
- High temperature plastic
- Four-wall shroud provides contact protection
- Contacts: 20, 26, 36, 40, 50, 60, 68, 80 and 100
- See the Regulatory Information Appendix (RIA) in the "RoHS compliance" section of www.3Mconnector.com for compliance information

Date Modified: June 15, 2012

TS-0334-B
Sheet 1 of 3

Physical

Insulator:

Material: High Temperature Plastic (LCP)

Flammability: UL 94V-0

Color: Black (RB Plating only) or Natural

Contact:

Material: Copper Alloy

Plating:

Underplating: 100 μ" [2.54 mm] Nickel

Wiping Area: 30 μ" [0.76 mm] Gold

Solder Tails: See Ordering Information

Terminal Finish Indicator: e3 (ref JESD97)

Marking: 3M Logo, Part Number and Orientation Triangle

Electrical

Current Rating: 0.5 A

Insulation Resistance: $> 1 \times 10^9 \Omega$ at 500 V_{DC}

Withstanding Voltage: 500 V_{RMS} at Sea Level

Environmental

Operating Temperature Rating: -55°C to +105°C

Process Rating: Maximum 260°C (Profile per J-STD-020C)

Moisture Sensitivity Level: 1 (per J-STD-020C)

UL File No.: E68080

3M

Electronic Solutions Division
Interconnect Solutions
<http://www.3Mconnector.com>

3M is a trademark of 3M Company.
For technical, sales or ordering information call
800-225-5373

3M™ 4-Wall, Tripolarized Header

.050" × .100" Latch/Ejector, Right Angle, 4 Rows of Solder Tails

810 Series

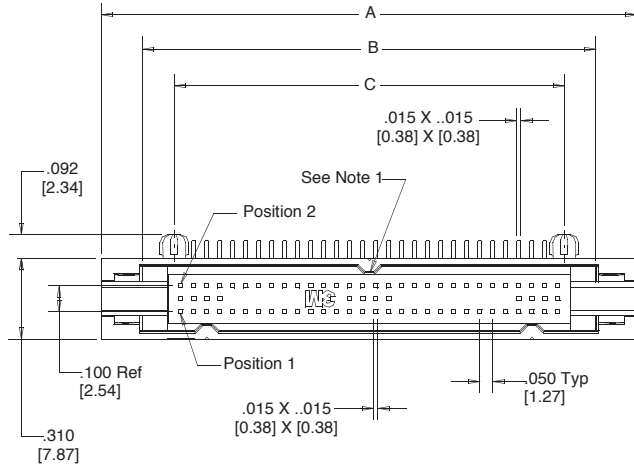

Contact Quantity	Dimensions				
	A	B	C	D Short (Ref.)	D Long (Ref.)
020	1.060 [26.92]	0.722 [18.34]	0.500 [12.70]	1.671 [42.44]	1.842 [46.79]
026	1.210 [30.73]	0.872 [22.15]	0.650 [16.51]	1.821 [46.25]	1.992 [50.60]
036	1.460 [37.08]	1.122 [28.50]	0.900 [22.86]	2.071 [52.60]	2.242 [56.95]
040	1.560 [39.62]	1.222 [31.04]	1.000 [25.40]	2.171 [55.14]	2.342 [59.49]
050	1.810 [45.97]	1.472 [37.39]	1.250 [31.75]	2.421 [61.49]	2.592 [65.84]
060	2.060 [52.32]	1.722 [43.74]	1.500 [38.10]	2.671 [67.84]	2.842 [72.19]
068	2.260 [57.40]	1.922 [48.82]	1.700 [43.18]	2.871 [72.92]	3.042 [77.27]
080	2.560 [65.02]	2.222 [56.44]	2.000 [50.80]	3.171 [80.54]	3.342 [84.89]
100	3.060 [77.72]	2.722 [69.14]	2.500 [63.50]	3.671 [93.24]	3.842 [97.59]

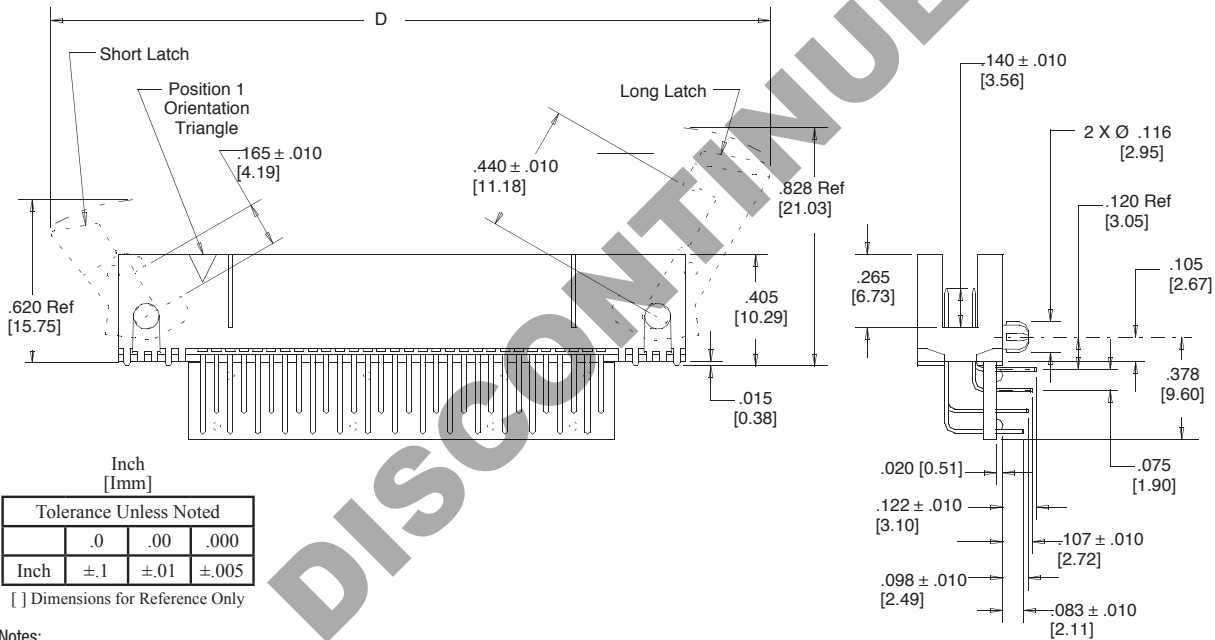

Tolerance Unless Noted			
Inch	±.1	±.01	±.005
.0	.00	.000	

[] Dimensions for Reference Only

- Notes:
1. This polarization bump does not exist on the 20 position header.
 2. Recommended to be mated to the .050" X .100" Wiremount Socket 820 Series.

Ordering Information PTH Right Angle Header, 4 Rows of Solder Tails

81XXX - MX0203 - XX

Contact Quantity (See Table 1)

Ejector/Latch System:
 0 = None
 5 = With Short Ejectors Installed
 6 = With Long Ejector Latches Installed

Plating suffix:
 blank = Tin lead tails (RIA E3 & C2 apply)
 RB = Matte tin tails (RIA E1 & C1 apply)

Ejector Latch
 Long
 3505-28 (natural)
 3505-28B (black)
 Short
 3505-29 (natural)
 3505-29B (black)

TS-0334-B
 Sheet 2 of 3

3M™ 4-Wall, Tripolarized Header

.050" × .100" Latch/Ejector, Right Angle, 4 Rows of Solder Tails

810 Series

Table 2	
Ejector Latches	Dimension E Min
None	.575 [14.61]
Long	1.010 [25.65]
Short	.885 [22.48]

Recommended Mounting Hole Pattern for Even Number of Contacts/Rows (shown for mounting side of PC Board)

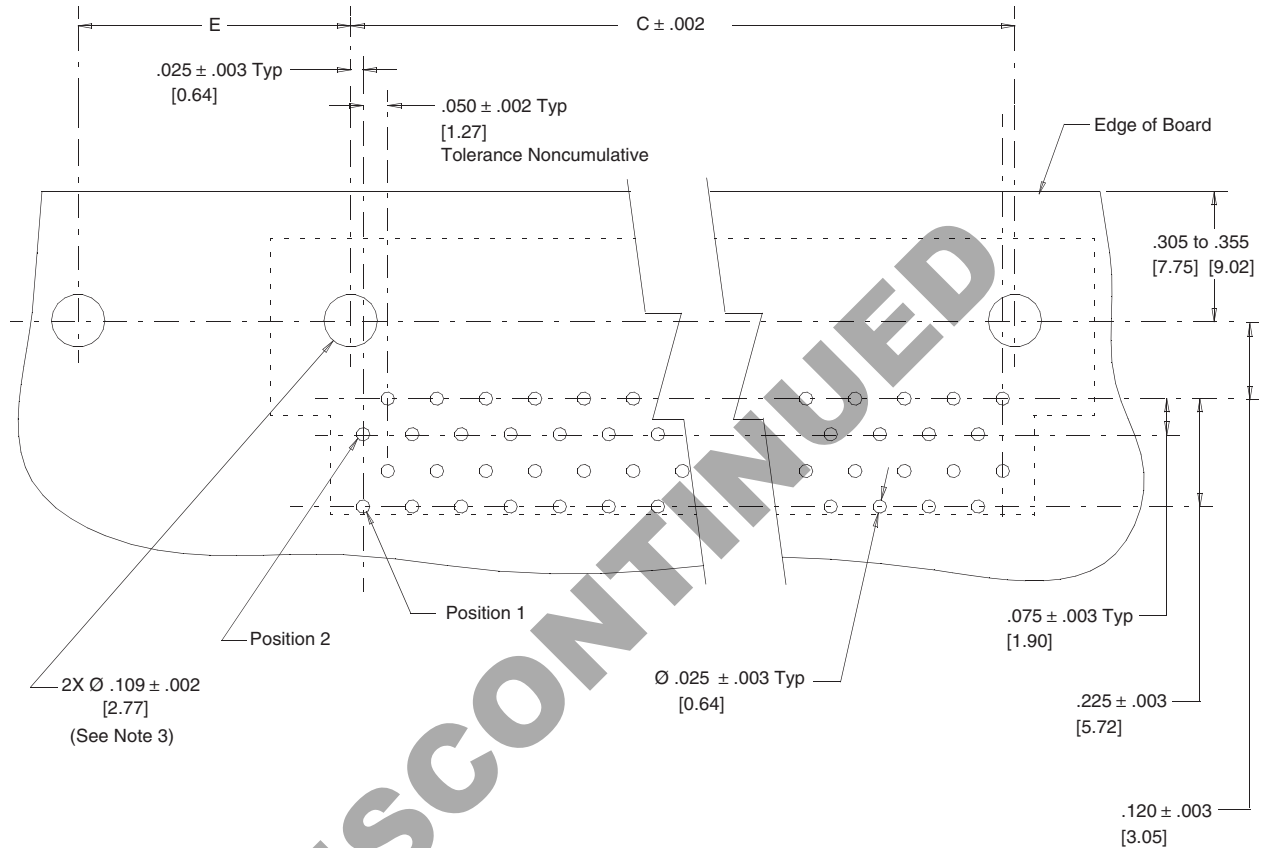

Recommended Mounting Hole Pattern for Odd Number of Contacts/Row (Shown for mounting side of PC Board)

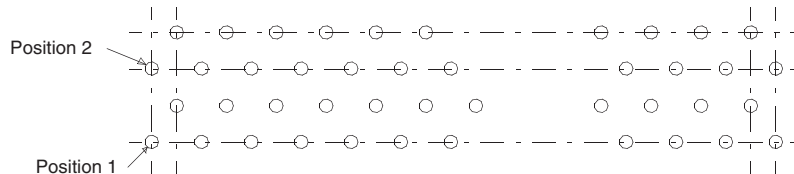

Notes:

1. In order to facilitate flow soldering, it is recommended that ejector latches be installed after the soldering process.

TS-0334-B
Sheet 3 of 3

DISCONTINUED

Important Notice

All statements, technical information, and recommendations related to 3M's products are based on information believed to be reliable, but the accuracy or completeness is not guaranteed. Before using this product, you must evaluate it and determine if it is suitable for your intended application. You assume all risks and liability associated with such use. Any statements related to the product which are not contained in 3M's current publications, or any contrary statements contained on your purchase order shall have no force or effect unless expressly agreed upon, in writing, by an authorized officer of 3M.

Warranty; Limited Remedy; Limited Liability.

This product will be free from defects in material and manufacture for a period of ninety (90) days from the time of purchase. **3M MAKES NO OTHER WARRANTIES INCLUDING, BUT NOT LIMITED TO, ANY IMPLIED WARRANTY OF MERCHANTABILITY OR FITNESS FOR A PARTICULAR PURPOSE.** If this product is defective within the warranty period stated above, your exclusive remedy shall be, at 3M's option, to replace or repair the 3M product or refund the purchase price of the 3M product. **Except where prohibited by law, 3M will not be liable for any indirect, special, incidental or consequential loss or damage arising from this 3M product, regardless of the legal theory asserted.**



3M Electronics Solutions Division

6801 River Place Blvd.
Austin, TX 78726-9000
U.S.A.
1-800-225-5373
www.3Mconnectors.com

Please recycle. Printed in USA.
© 3M 2012. All rights reserved.
RIA-2217B-E

3M is a trademark of 3M Company.



Компания «ЭлектроПласт» предлагает заключение долгосрочных отношений при поставках импортных электронных компонентов на взаимовыгодных условиях!

Наши преимущества:

- Оперативные поставки широкого спектра электронных компонентов отечественного и импортного производства напрямую от производителей и с крупнейших мировых складов;
- Поставка более 17-ти миллионов наименований электронных компонентов;
- Поставка сложных, дефицитных, либо снятых с производства позиций;
- Оперативные сроки поставки под заказ (от 5 рабочих дней);
- Экспресс доставка в любую точку России;
- Техническая поддержка проекта, помощь в подборе аналогов, поставка прототипов;
- Система менеджмента качества сертифицирована по Международному стандарту ISO 9001;
- Лицензия ФСБ на осуществление работ с использованием сведений, составляющих государственную тайну;
- Поставка специализированных компонентов (Xilinx, Altera, Analog Devices, Intersil, Interpoint, Microsemi, Aeroflex, Peregrine, Syfer, Eurofarad, Texas Instrument, Miteq, Cobham, E2V, MA-COM, Hittite, Mini-Circuits, General Dynamics и др.);

Помимо этого, одним из направлений компании «ЭлектроПласт» является направление «Источники питания». Мы предлагаем Вам помощь Конструкторского отдела:

- Подбор оптимального решения, техническое обоснование при выборе компонента;
- Подбор аналогов;
- Консультации по применению компонента;
- Поставка образцов и прототипов;
- Техническая поддержка проекта;
- Защита от снятия компонента с производства.



Как с нами связаться

Телефон: 8 (812) 309 58 32 (многоканальный)

Факс: 8 (812) 320-02-42

Электронная почта: org@eplast1.ru

Адрес: 198099, г. Санкт-Петербург, ул. Калинина, дом 2, корпус 4, литера А.