

Rocker Switch with External Reset Function for High capacity Switching

- Energy-saving reset function triggered with external signals.
- Incorporates unique switching mechanism switching 20 A with excellent inrush-current durability.
- Double-pole, double-throw (DPDT) contact.
- Contact gap of 3 mm minimum.
- UL and cUL standard approved.
Conforms to EN standards.



RoHS Compliant

Caution
Refer to Precautions

List of Models

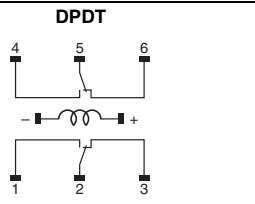
Contact Form	DPDT 	Quantity per box
Color of cases	Black	50
Cap color	Black	
Model	A8G-107-1-24	

Ratings

Rated load	Non-inductive		Inductive	
	Resistive load	Lamp load	Inductive load	Motor load
250 VAC	20A	10A	8A	8A

- Note:**
1. The non-inductive lamp load has an inrush current 10 times steady current.
 2. The inductive load has a power factor of 0.4 minimum (AC).
 3. The motor load has an inrush current 6 times steady current.

The above ratings were tested under the following conditions:

1. Ambient temperature: 20±2 °C
2. Ambient humidity: 65±5 %RH
3. Switching frequency: 7 times/min.

Reset Coil

Rated voltage (operating voltage range)	Reset voltage (coil temperature: 20°C±2°C)	Rated energized current (coil temperature: 20°C±2°C)	Coil resistance (coil temperature: 20°C±2°C)	Permissible voltage applied period
24 VDC±10% (21.6 to 26.4 VDC)	21.6 V max.	185 mA±20%	130 Ω±20%	100 ms for min 1 s max.

- Note:**
1. Current must not flow for more than 10 s, otherwise the performance of the coil may be affected.
 2. If a semiconductor element is used to control the reset coil, the residual voltage caused by leakage current must be 2.4 VDC max.

Approved Standards

UL, cUL (UL 1054/CSA C22.2 No.55)

20A 250 VAC

KEMA (EN61058-1)

20(8)A 250 VAC

Characteristics

Permissible operating frequency	Mechanical	20 operations/min max.
	Electrical	Switching frequency: 7 times/min.; Coil operation: 7 times/min.
Insulation resistance		100 MΩ min. (500 VDC)
Dielectric strength	Between terminals of the same polarity	2,000 VAC, 50/60 Hz, for 1 min
	Between terminals of the different polarity	2,000 VAC, 50/60 Hz, for 1 min
	Between charged metal parts and the ground terminal	4,000 VAC, 50/60 Hz, for 1 min
Vibration resistance	Malfunction	10 to 55 Hz, 1.5-mm double amplitude
Shock resistance	Malfunction	98 m/s ² (10G)
	Destruction	500 m/s ² (50G) max.
Durability	Mechanical	Switching operation 100,000 times min.
	Electrical	Switching operation 50,000 times min.
Contact release time (see note)		100 ms max.
Ambient operating temperature		-10 to +55 °C (with no icing or condensation)
Ambient operating humidity		45 to 85 %RH

Note: For the condition in individual standard, contact your OMRON sales representative.

Contact release time is the period of time during which contacts 1 and 2 and contacts 4 and 5 are released after voltage is imposed on the coil.

Operation

Item	No excitation, load 1 turned off, and load 2 turned on	No excitation, load 1 turned on, and load 2 turned off	Excitation, load 1 turned off, and load 2 turned on
Operation	<p>Permanent magnet Coil Reset spring</p>	<p>Manual operation</p> <p>The permanent magnet keeps the moving iron and iron core in contact.</p>	<p>Automatic reset</p> <p>The coil is excited and the moving iron is reset with the reset spring.</p>
Circuit configuration			<p>24 VDC applied to coil terminal</p>

■Dimensions (Unit: mm)

A8G

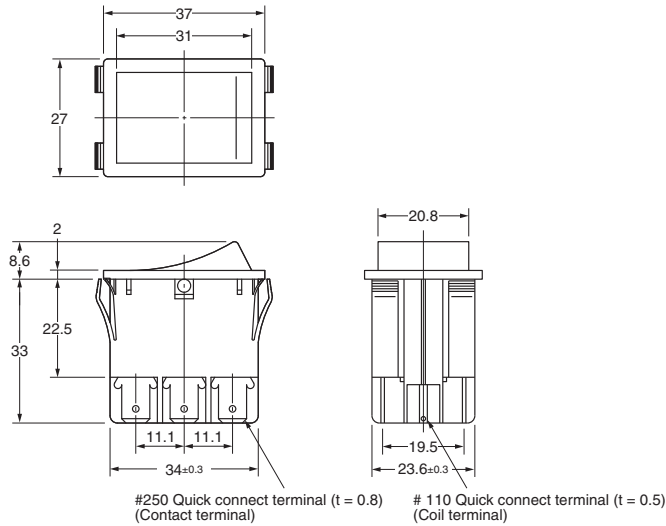
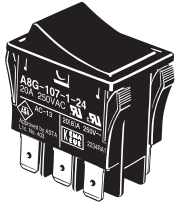

Note: Unless otherwise specified, a tolerance of ±0.8 mm applies to all dimensions.

■Operating Characteristics

Operating force (OF) max.	19.6 N {2,000 gf}
----------------------------------	-------------------

■Panel Cutout

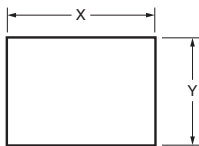

Panel thickness	X	Y
1.6 to 3.0 mm	34.4 ^{+0.2} ₀ mm	24.4 ^{+0.3} ₀ mm

Note: Recommended panel material: SPCC

Consult your OMRON representative when using a panel with a thickness other than the above.

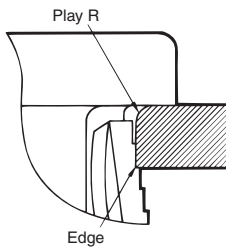

When processing the panel, be sure that the Play R is on the switch operation side. Be sure that the Edge is on the reverse side of panel when processing.

■Contact Form

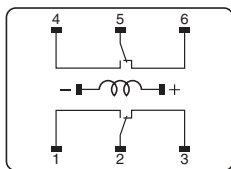

1 to 6: Contact terminals
-, +: Coil terminals

Note: When 24 VDC is applied to the coil, contacts 2 and 3 and contacts 5 and 6 are ON.

■Precautions

Be sure to read the Safety precautions common to all Rocker Switches for correct use.

- Application examples provided in this document are for reference only. In actual applications, confirm equipment functions and safety before using the product.
- Consult your OMRON representative before using the product under conditions which are not described in the manual or applying the product to nuclear control systems, railroad systems, aviation systems, vehicles, combustion systems, medical equipment, amusement machines, safety equipment, and other systems or equipment that may have a serious influence on lives and property if used improperly. Make sure that the ratings and performance characteristics of the product provide a margin of safety for the system or equipment, and be sure to provide the system or equipment with double safety mechanisms.

Note: Do not use this document to operate the Unit.

OMRON Corporation

ELECTRONIC AND MECHANICAL COMPONENTS COMPANY

Contact: www.omron.com/ecb

Cat. No. A106-E1-04
1212(0207)(O)



Компания «ЭлектроПласт» предлагает заключение долгосрочных отношений при поставках импортных электронных компонентов на взаимовыгодных условиях!

Наши преимущества:

- Оперативные поставки широкого спектра электронных компонентов отечественного и импортного производства напрямую от производителей и с крупнейших мировых складов;
- Поставка более 17-ти миллионов наименований электронных компонентов;
- Поставка сложных, дефицитных, либо снятых с производства позиций;
- Оперативные сроки поставки под заказ (от 5 рабочих дней);
- Экспресс доставка в любую точку России;
- Техническая поддержка проекта, помощь в подборе аналогов, поставка прототипов;
- Система менеджмента качества сертифицирована по Международному стандарту ISO 9001;
- Лицензия ФСБ на осуществление работ с использованием сведений, составляющих государственную тайну;
- Поставка специализированных компонентов (Xilinx, Altera, Analog Devices, Intersil, Interpoint, Microsemi, Aeroflex, Peregrine, Syfer, Eurofarad, Texas Instrument, Miteq, Cobham, E2V, MA-COM, Hittite, Mini-Circuits, General Dynamics и др.);

Помимо этого, одним из направлений компании «ЭлектроПласт» является направление «Источники питания». Мы предлагаем Вам помощь Конструкторского отдела:

- Подбор оптимального решения, техническое обоснование при выборе компонента;
- Подбор аналогов;
- Консультации по применению компонента;
- Поставка образцов и прототипов;
- Техническая поддержка проекта;
- Защита от снятия компонента с производства.



Как с нами связаться

Телефон: 8 (812) 309 58 32 (многоканальный)

Факс: 8 (812) 320-02-42

Электронная почта: org@eplast1.ru

Адрес: 198099, г. Санкт-Петербург, ул. Калинина, дом 2, корпус 4, литера А.