



Main

Range of product	Harmony XB5R
Product or component type	Wireless and batteryless transmitter
Device short name	XB5R
Kit composition	1 ZBRM21 handy box 1 ZBA80 set of caps 1 ZBRT2 transmitter
Contact operation	1 double action UP/DOWN push-buttons
Bezel material	Plastic
Fixing collar material	Plastic
Mounting diameter	0.87 in (22 mm)

Complementary

Shape of signaling unit head	Round
Type of operator	Spring return push-button with transmitter
Operator profile	Flush
Operator additional information	Set of caps
Product weight	0.33 lb(US) (0.15 kg)
Mechanical durability	400000 cycles
Operating travel	0.17 in (4.3 mm) total travel
Operating force	< 25 N C/O changing electrical state
Shock resistance	25 gn (duration = 6 ms) 6000 shocks conforming to IEC 60068-2-27 30 gn (duration = 18 ms) half sine wave acceleration conforming to IEC 60068-2-27 50 gn (duration = 11 ms) half sine wave acceleration conforming to IEC 60068-2-27
Mechanical robustness	Free fall resistance (test level: 1000 mm) conforming to EN/IEC 60068-2-32
Communication port protocol	Zigbee green power at 2.4 GHz
Maximum sensing distance	328.08 ft (100 m) (in free field) 25 m (transmitter in the handy box and receiver in a metal enclosure) 300 m (transmitter in the handy box, receiver in metal enclosure and use relay-antenna)
Acquisition time	2 ms
Response time	< 2 ms
Emission power	3 mW

Environment

ambient air temperature for storage	-40...158 °F (-40...70 °C)
ambient air temperature for operation	-13...131 °F (-25...55 °C)
IP degree of protection	IP65 on front face conforming to IEC 60529 IP65 on front face conforming to UL Type 12
IK degree of protection	IK03 conforming to IEC 50102
relative humidity	95 % at 158 °F (70 °C) without condensation
vibration resistance	+/- 10 mm (f = 2...11 Hz) conforming to IEC 60068-2-6 5 gn (f = 11...500 Hz) conforming to IEC 60068-2-6
electromagnetic compatibility	Immunity for industrial environments Radiated emission Susceptibility to electromagnetic fields: 3 V/m, 80...2700 MHz, distance = 20 m Susceptibility to electromagnetic fields: 10 V/m, 80...2000 MHz Electrostatic discharge immunity test: 6 kV, on contact (on metal parts) Electrostatic discharge immunity test: 8 kV, in free air (in insulating parts)
radio agreement	RSS SRRC ICASA ANATEL ARIB T66

The information provided in this documentation contains general descriptions and/or technical characteristics of the products contained herein. This documentation is not intended as a substitute for and is not to be used for determining suitability or reliability of these products for specific user applications. It is the duty of any such user or integrator to perform the appropriate and complete risk analysis, evaluation and testing of the products with respect to the relevant specific application or use thereof. Neither Schneider Electric Industries SAS nor any of its affiliates or subsidiaries shall be responsible or liable for misuse of the information contained herein.

	FCC
standards	EN/IEC 60947-1 EN/IEC 60947-5-1 UL 508 CSA C22.2 No 14
product certifications	CCC CSA C-Tick UL BT 2006/95/EC EAC
directives	2004/108/EC - electromagnetic compatibility 1999/5/EC - R&TTE directive

Offer Sustainability

WARNING: This product can expose you to chemicals including:

Lead and lead compounds, which is known to the State of California to cause cancer and birth defects or other reproductive harm.

For more information go to www.p65warnings.ca.gov

WARNING: This product can expose you to chemicals including:

Lead and lead compounds, which is known to the State of California to cause cancer and birth defects or other reproductive harm.

For more information go to www.p65warnings.ca.gov

Dimensions

Wireless and Batteryless Pushbutton

Plastic Mobile Box for Mobile or Fix Use - 1 Function

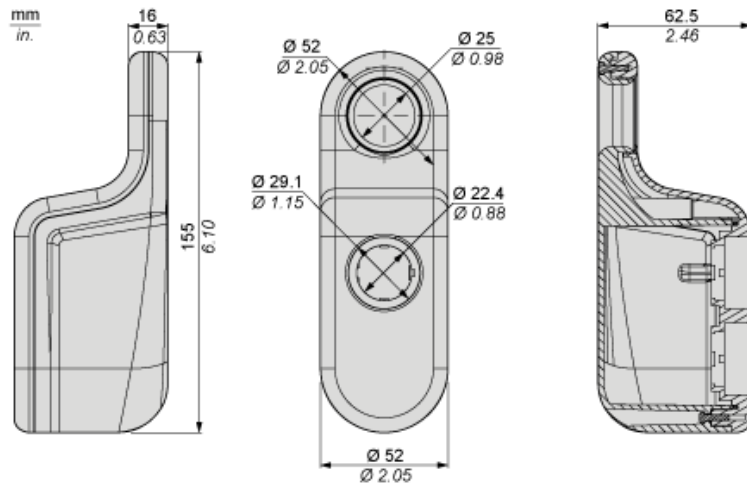



Компания «ЭлектроПласт» предлагает заключение долгосрочных отношений при поставках импортных электронных компонентов на взаимовыгодных условиях!

Наши преимущества:

- Оперативные поставки широкого спектра электронных компонентов отечественного и импортного производства напрямую от производителей и с крупнейших мировых складов;
- Поставка более 17-ти миллионов наименований электронных компонентов;
- Поставка сложных, дефицитных, либо снятых с производства позиций;
- Оперативные сроки поставки под заказ (от 5 рабочих дней);
- Экспресс доставка в любую точку России;
- Техническая поддержка проекта, помощь в подборе аналогов, поставка прототипов;
- Система менеджмента качества сертифицирована по Международному стандарту ISO 9001;
- Лицензия ФСБ на осуществление работ с использованием сведений, составляющих государственную тайну;
- Поставка специализированных компонентов (Xilinx, Altera, Analog Devices, Intersil, Interpoint, Microsemi, Aeroflex, Peregrine, Syfer, Eurofarad, Texas Instrument, Miteq, Cobham, E2V, MA-COM, Hittite, Mini-Circuits, General Dynamics и др.);

Помимо этого, одним из направлений компании «ЭлектроПласт» является направление «Источники питания». Мы предлагаем Вам помощь Конструкторского отдела:

- Подбор оптимального решения, техническое обоснование при выборе компонента;
- Подбор аналогов;
- Консультации по применению компонента;
- Поставка образцов и прототипов;
- Техническая поддержка проекта;
- Защита от снятия компонента с производства.



Как с нами связаться

Телефон: 8 (812) 309 58 32 (многоканальный)

Факс: 8 (812) 320-02-42

Электронная почта: org@eplast1.ru

Адрес: 198099, г. Санкт-Петербург, ул. Калинина, дом 2, корпус 4, литера А.