

FEATURES

- 0...1 to 0...100 psi
- DIP package
- Temperature compensated
- Calibrated zero and span
- Small size
- Low noise
- High impedance for low power applications

APPLICATIONS

- Medical equipment
- Computer peripherals
- Pneumatic controls
- HVAC

GENERAL DESCRIPTION

The SDX series sensors will provide a very cost effective solution for pressure applications that require small size plus performance. These calibrated and temperature compensated sensors give an accurate and stable output over a 0 to 50°C temperature range. SDX devices are available in standard commercial and prime grades to allow optimization of accuracy and cost in any given application. This series is intended for use with non-corrosive, non-ionic working fluids such as air, dry gases and the like.

Devices are available to measure absolute and gage pressures from 1 up to 100 psi. The absolute devices have an internal vacuum reference and an output voltage proportional to absolute pressure.

The output of the bridge is ratiometric to the supply voltage and operation from any D.C. supply voltage up to +20 V is acceptable.

The SDX devices feature an integrated circuit sensor element and laser trimmed thick film ceramic housed in a compact solvent resistant case.

The package is a double wide (i.e., 0.600" lead spacing) dual-inline-package. This is the same familiar package used by IC manufacturers except it is only 0.470" long and



Scale: 1 cm
1/2 inch

has a pressure port(s). The PC board area used by each DIP is approximately 0.26 square inches. This extremely small size enables the use of multiple sensors in limited available space. The DIP provides excellent corrosion resistance and isolation to external package stress.

The DIP mounts on a PC board like a standard IC with through-hole pins. The pins anchor the pressure sensor to the PC board and provide a more secure and stable unit than other types of packages.

EQUIVALENT CIRCUIT

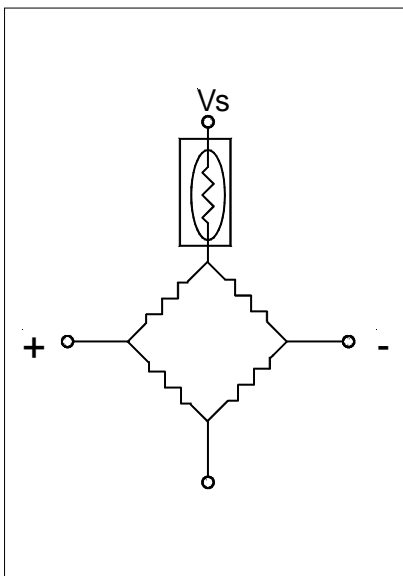

ELECTRICAL CONNECTION

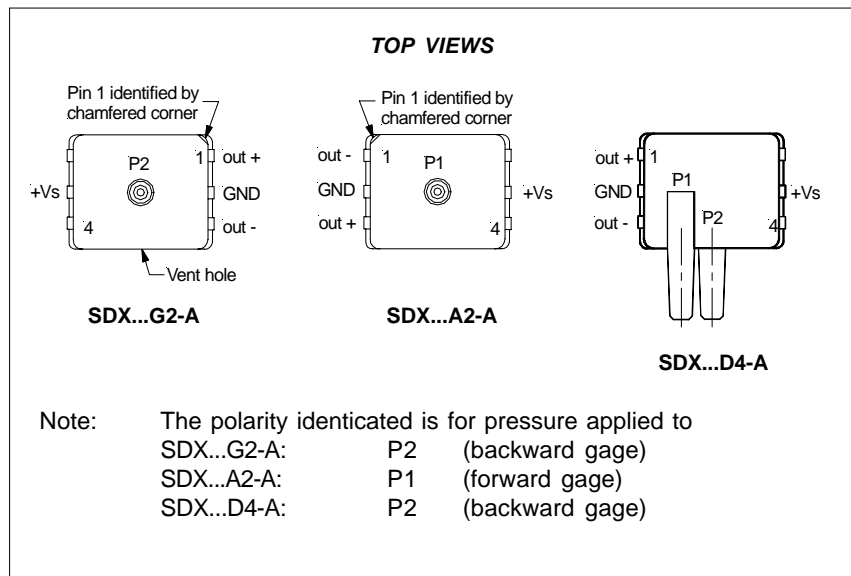

PRESSURE SENSOR CHARACTERISTICS (all devices)
Maximum ratings

Supply voltage V_s	+20 V_{DC}
Maximum pressure on any port	150 psig
Lead temperature (soldering 4 sec.)	250°C

Environmental specifications

Temperature ranges	0 to 50°C
Compensated	-40 to +85°C
Operating	-55 to +125°C
Storage	0 to 100% RH
Humidity limits	

STANDARD PRESSURE RANGES

Part number	Operating pressure	Proof ¹¹ pressure	Full scale span ^{1,2}		
			Min.	Typ.	Max.
SDX01...	0 - 1 psi	20 psi	17.82 mV	18.0 mV	18.18 mV
SDX05...	0 - 5 psi	20 psi	59.40 mV	60.0 mV	60.60 mV
SDX15...	0 - 15 psi	30 psi	89.10 mV	90.0 mV	90.90 mV
SDX30...	0 - 30 psi	60 psi	89.10 mV	90.0 mV	90.90 mV
SDX100...	0 - 100 psi	150 psi	99.00 mV	100.0 mV	101.00 mV

COMMON PERFORMANCE CHARACTERISTICS¹

Characteristics	Min.	Typ.	Max.	Unit
Zero pressure offset	-0.300	0	+0.300	mV
Combined linearity and hysteresis ³		±0.1	±0.25	%FSO
Temperature effects (0 to 50°C) ⁴	Offset	±0.2	±0.5	mV
	Span	±0.4	±1.0	%FSO
Repeatability ⁵		±0.2	±0.5	
Input impedance ⁶		4.0		kΩ
Output impedance ⁷		4.0		
Common mode voltage ⁸	1.5	3.0	5.0	V_{DC}
Response time ⁹		100		µsec
Long term stability of offset and span ¹⁰		±0.1		mV

Specification notes:

- Reference conditions (unless otherwise noted): supply voltage, $V_s = 12V_{DC}$; $T_A = 25°C$; common mode line pressure = 0 psig; pressure applied to port 2. For absolute devices only, pressure is applied to port 1 and the output polarity is reversed.
- Span is the algebraic difference between the output voltage at full scale pressure and the output at zero pressure. Span is ratiometric to the supply voltage.
- Hysteresis is the maximum output difference at any point within the operating pressure range for increasing and decreasing pressure. Maximum linearity & hysteresis for the SDX05 is 0.5 %FSO.
- Maximum error band of the offset voltage and the error band of the span, relative to the 25°C reading.
- Maximum difference in output at any pressure within the operating pressure range and temperature within 0 to +50°C after:
 - 100 temperature cycles, 0 to +50°C.
 - 1.0 million pressure cycles, 0 psi to full scale span.
- Input impedance is the impedance between V_s and ground.
- Output impedance is the impedance between + and - outputs.
- This is the common mode voltage of the output arms for $V_s = 12 V_{DC}$.
- Response time for a 0 psi to full scale span pressure step change, 10 to 90 % rise time.
- Long term stability over a one year period.
- If the maximum pressure is exceeded, even momentarily, the package may leak or burst, or the pressure sensing die may fracture. The proof pressure for the forward gage of all devices in the D4-package is the specified value or 100 psi, whatever is less.

PHYSICAL DIMENSIONS

SDX...G2-A,
SDX...A2-A

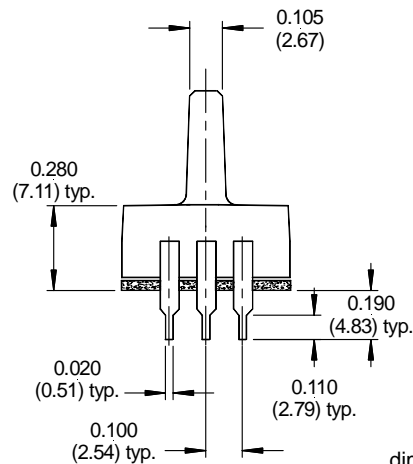
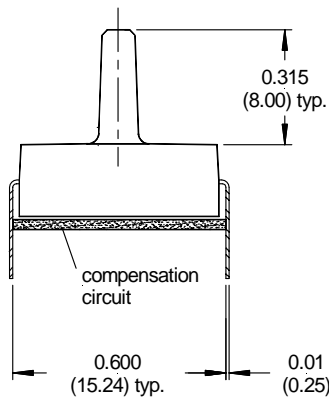
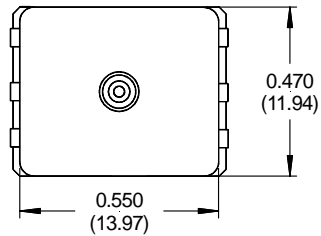

mass: 2 g

dimensions in inches (mm)

SDX...D4-A

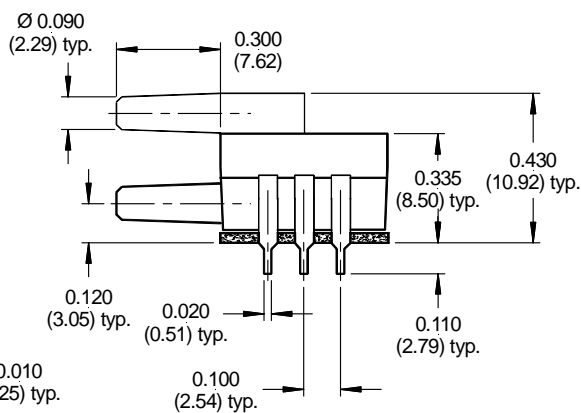
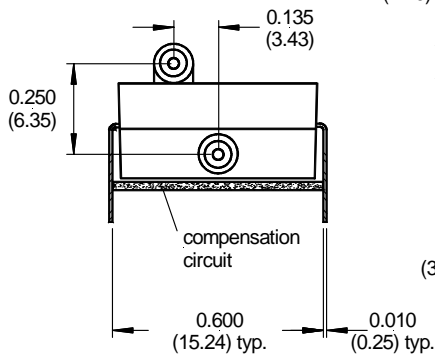
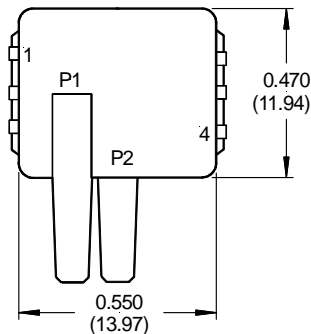

mass: 2 g

dimensions in inches (mm)

GENERAL DISCUSSION

The SDX series devices give a voltage output which is directly proportional to applied pressure. The gage devices will give an increasing positive going output when increasing pressure is applied to the pressure port. The absolute device will give a decreasing output when increasing pressure is applied to the port. The devices are ratiometric to the supply voltage and changes in the supply voltage will cause proportional changes in the offset voltage and full-scale span.

PNEUMATIC INTERFACE

The DIP also provides convenient mounting and pressure ports for ease of use with standard 1/16" ID, 1/8" OD, 1/32" wall, flexible plastic tubing for pressure connection.

The small tubing has several advantages over larger tubing commonly used with pressure sensors:

- 1) The tubing can be formed in a much smaller radius without kinking.
- 2) The tubing is easier to handle.
- 3) The tubing is available in a variety of colors such as clear, white, yellow, blue, green etc. to enable color coding of pneumatic circuits with multiple pressure sensors in the same way that wiring harnesses are color coded in electrical circuits. This greatly simplifies troubleshooting.
- 4) Less stress is placed on the pressure sensor package resulting in less potential for offset shift.
- 5) Less physical space is required for the small tubing.
- 6) The lower volume of air in the small tubing results in faster pressure sensor response.

USER CALIBRATION

The SDX devices are fully calibrated for offset and span and should therefore require little user adjustment in most applications. For more precise span and offset adjustments, contact the factory.

VACUUM REFERENCE (absolute devices)

Absolute sensors have a hermetically sealed vacuum reference chamber. The offset voltage on these units is therefore measured at vacuum, 0 psia. Since all pressure is measured relative to a vacuum reference, all changes in barometric pressure or changes in altitude will cause changes in the device output.

MEDIA COMPATIBILITY

SDX devices are compatible with most non-corrosive gases. Because the circuitry is coated with a protective silicon gel, many otherwise corrosive environments can be compatible with the sensors. Fluids must generally be compatible with silicon gel, plastic, RTV, silicon, and glass for use with the gage devices (only). For questions concerning media compatibility, contact the factory.

MECHANICAL AND MOUNTING CONSIDERATIONS

The DIP housing is designed for convenient pressure connection and easy PC board mounting. For pressure attachment, tygon and silicon tubing is recommended.

APPLICATION INFORMATION

The application information for the SCX series is also applicable to the SDX series.

ORDERING INFORMATION

Pressure range	Order number		
	Absolute	Gage	Differential/Gage
0 - 1 psi		SDX01G2-A	SDX01D4-A
0 - 5 psi		SDX05G2-A	SDX05D4-A
0 - 15 psi	SDX15A2-A	SDX15G2-A	SDX15D4-A
0 - 30 psi	SDX30A2-A	SDX30G2-A	SDX30D4-A
0 - 100 psi	SDX100A2-A	SDX100G2-A	SDX100D4-A

All devices are marked with SDX...A2 or SDX...G2 or SDX...D4 and a golden color dot.

SenSym and Sensortechonics reserve the right to make changes to any products herein. SenSym and Sensortechonics do not assume any liability arising out of the application or use of any product or circuit described herein, neither does it convey any license under its patent rights nor the rights of others.



Компания «ЭлектроПласт» предлагает заключение долгосрочных отношений при поставках импортных электронных компонентов на взаимовыгодных условиях!

Наши преимущества:

- Оперативные поставки широкого спектра электронных компонентов отечественного и импортного производства напрямую от производителей и с крупнейших мировых складов;
- Поставка более 17-ти миллионов наименований электронных компонентов;
- Поставка сложных, дефицитных, либо снятых с производства позиций;
- Оперативные сроки поставки под заказ (от 5 рабочих дней);
- Экспресс доставка в любую точку России;
- Техническая поддержка проекта, помощь в подборе аналогов, поставка прототипов;
- Система менеджмента качества сертифицирована по Международному стандарту ISO 9001;
- Лицензия ФСБ на осуществление работ с использованием сведений, составляющих государственную тайну;
- Поставка специализированных компонентов (Xilinx, Altera, Analog Devices, Intersil, Interpoint, Microsemi, Aeroflex, Peregrine, Syfer, Eurofarad, Texas Instrument, Miteq, Cobham, E2V, MA-COM, Hittite, Mini-Circuits, General Dynamics и др.);

Помимо этого, одним из направлений компании «ЭлектроПласт» является направление «Источники питания». Мы предлагаем Вам помощь Конструкторского отдела:

- Подбор оптимального решения, техническое обоснование при выборе компонента;
- Подбор аналогов;
- Консультации по применению компонента;
- Поставка образцов и прототипов;
- Техническая поддержка проекта;
- Защита от снятия компонента с производства.



Как с нами связаться

Телефон: 8 (812) 309 58 32 (многоканальный)

Факс: 8 (812) 320-02-42

Электронная почта: org@eplast1.ru

Адрес: 198099, г. Санкт-Петербург, ул. Калинина, дом 2, корпус 4, литера А.