

THIS DRAWING IS UNPUBLISHED. RELEASED FOR PUBLICATION 20
 © COPYRIGHT 20 BY - ALL RIGHTS RESERVED.

LOC		DIST		REVISIONS			
P	LTR	DESCRIPTION	DATE	DWN	APVD		
G		ECR-13-018192	27NOV2013	TB	DM		
H		ECR-15-001933	16FEB2015	TB	DM		

2106391-1 SHOWN

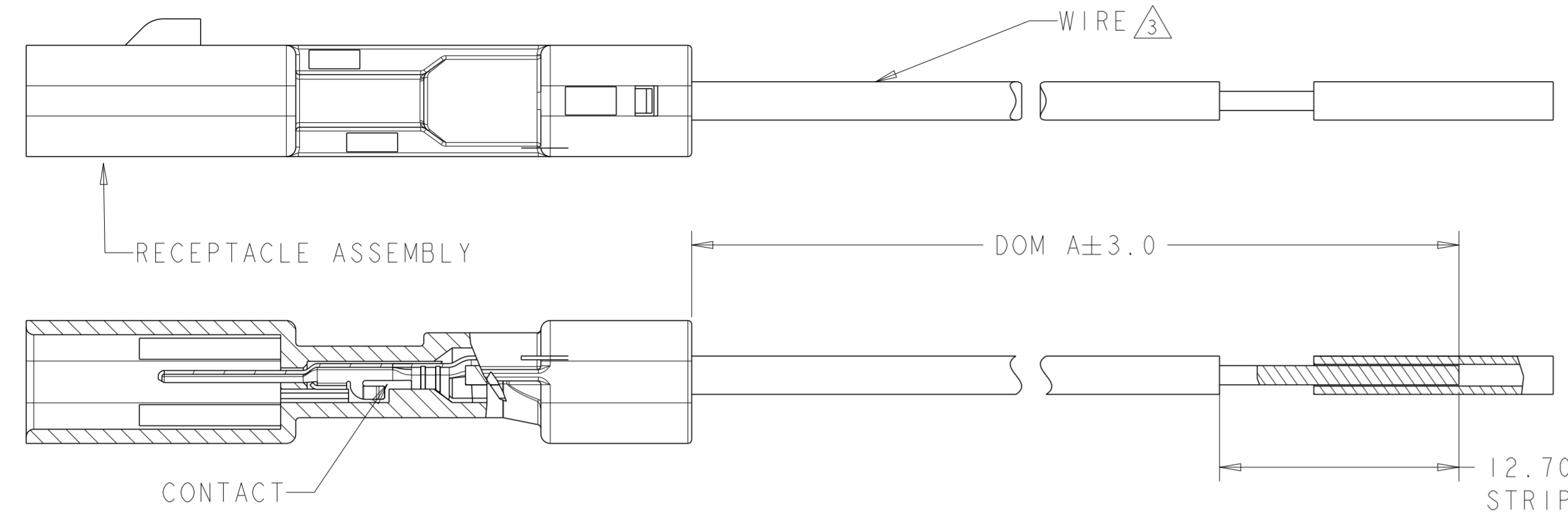

2106391-2, 2106391-5, 2106391-8, 1-2106391-1, 1-2106391-4, 1-2106391-7, 2-2106391-0, 2-2106391-3, 2-2106391-6, 2-2106391-7 and 2-2106391-8 SHOWN

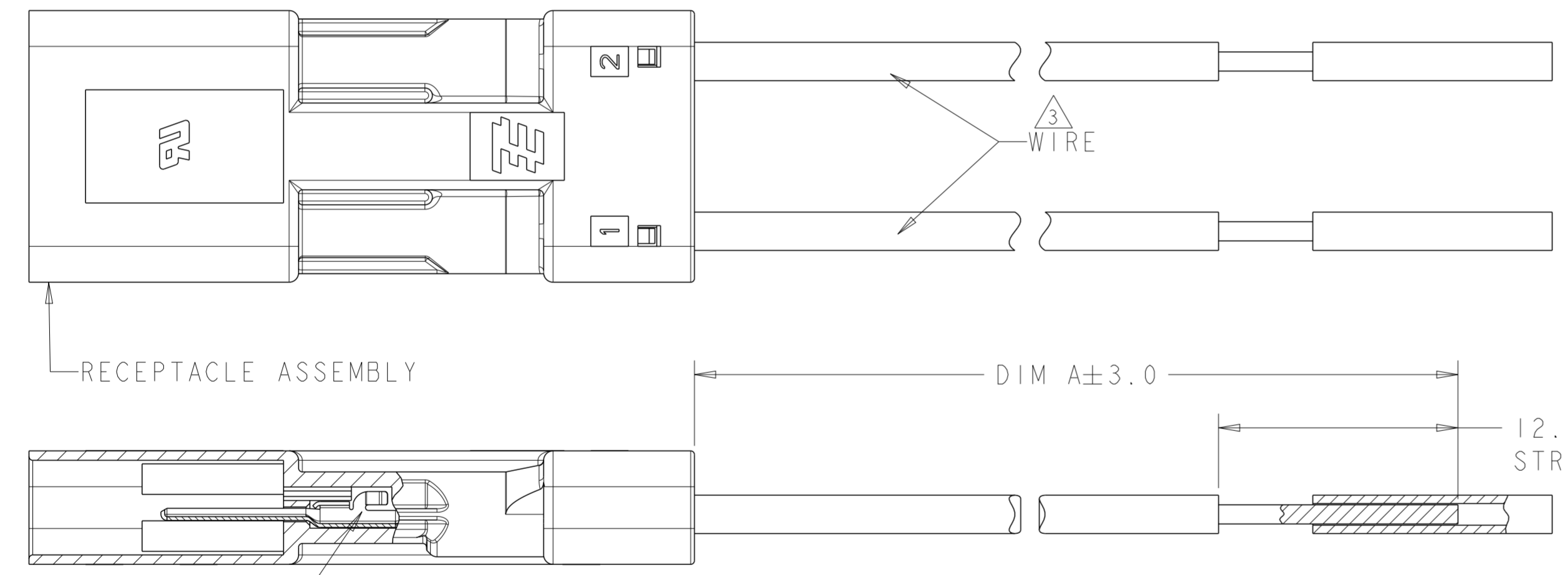

DIM A	WIRE SIZE	POSN	PART NO.
2000.0	20 AWG	2	2-2106391-8
5000.0	18 AWG	2	2-2106391-7
381.0	18 AWG	2	2-2106391-6
304.8	24 AWG	4	2-2106391-5
304.8	24 AWG	3	2-2106391-4
304.8	24 AWG	2	2-2106391-3
101.6	24 AWG	4	2-2106391-2
101.6	24 AWG	3	2-2106391-1
101.6	24 AWG	2	2-2106391-0
304.8	22 AWG	4	1-2106391-9
304.8	22 AWG	3	1-2106391-8
304.8	22 AWG	2	1-2106391-7
101.6	22 AWG	4	1-2106391-6
101.6	22 AWG	3	1-2106391-5
101.6	22 AWG	2	1-2106391-4
304.8	20 AWG	4	1-2106391-3
304.8	20 AWG	3	1-2106391-2
304.8	20 AWG	2	1-2106391-1
101.6	20 AWG	4	1-2106391-0
101.6	20 AWG	3	2106391-9
101.6	20 AWG	2	2106391-8
304.8	18 AWG	4	2106391-7
304.8	18 AWG	3	2106391-6
304.8	18 AWG	2	2106391-5
101.6	18 AWG	4	2106391-4
101.6	18 AWG	3	2106391-3
101.6	18 AWG	2	2106391-2
101.6	18 AWG	1	2106391-1

POS	-1	-2	-3	-4	-5	-6	-7	-8	-9	-10	-11	-12	-13	-14	-15	-16	-17	-18	-19	-20	-21	-22	-23	-24	-25	-26	-27	-28
4	-	-	-	BLUE	-	-	BLUE	-	-	BLUE	-	-	BLUE	-	-	BLUE	-	-	BLUE	-	-	BLUE	-	-	BLUE	-	-	-
3	-	-	WHITE	WHITE	-	WHITE	WHITE	-	WHITE	WHITE	-	WHITE	WHITE	-	WHITE	WHITE	-	WHITE	WHITE	-	WHITE	WHITE	-	WHITE	WHITE	-	WHITE	WHITE
2	-	RED	RED	RED	RED	RED	RED	RED	RED	RED	RED	RED	RED	RED	RED	RED	RED	RED	RED	RED	RED	RED	RED	RED	RED	RED	RED	RED
1	BLACK	BLACK	BLACK	BLACK	BLACK	BLACK	BLACK	BLACK	BLACK	BLACK	BLACK	BLACK	BLACK	BLACK	BLACK	BLACK	BLACK	BLACK	BLACK	BLACK	BLACK	BLACK	BLACK	BLACK	BLACK	BLACK	BLACK	BLACK

- △ MATERIALS AND FINISH:
 - CONTACTS: COPPER ALLOY
 - FINISH: TIN IN CONTACT AREA OVER NICKEL UNDERPLATE
 - WIRE: 18 AWG, STRANDED, UL 1007 STYLE
- 2. MUST COMPLY WITH DIRECTIVE 2002/95/EC (ROHS)
- △ REFERENCE CHART FOR SPECIFIC WIRE COLOR/POSITION

THIS DRAWING IS A CONTROLLED DOCUMENT.

DWN: R BROWN 20APR2009
 CHK: M MOSTOLLER 20APR2009
 APVD: -

TE Connectivity

CABLE ASSEMBLY, RECEPTACLE, SLIMSEAL SSL CONNECTOR

SIZE: A2 CAGE CODE: 00779 DRAWING NO: 2106391 RESTRICTED TO: -

Customer Drawing SCALE: 4:1 SHEET 1 OF 3 REV H

THIS DRAWING IS UNPUBLISHED. RELEASED FOR PUBLICATION 20
 © COPYRIGHT 20 BY - ALL RIGHTS RESERVED.

LOC		DIST		REVISIONS			
P	LTR	DESCRIPTION	DATE	DWN	APVD		
-	-	SEE SHEET 1	-	-	-		

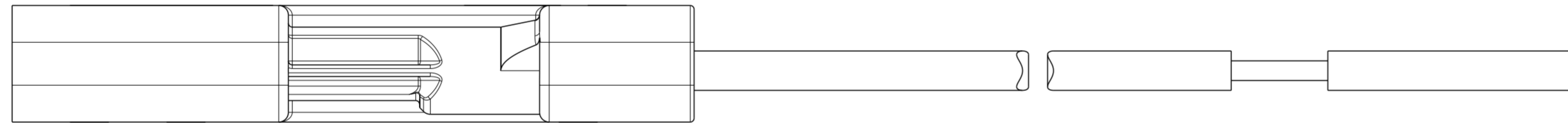
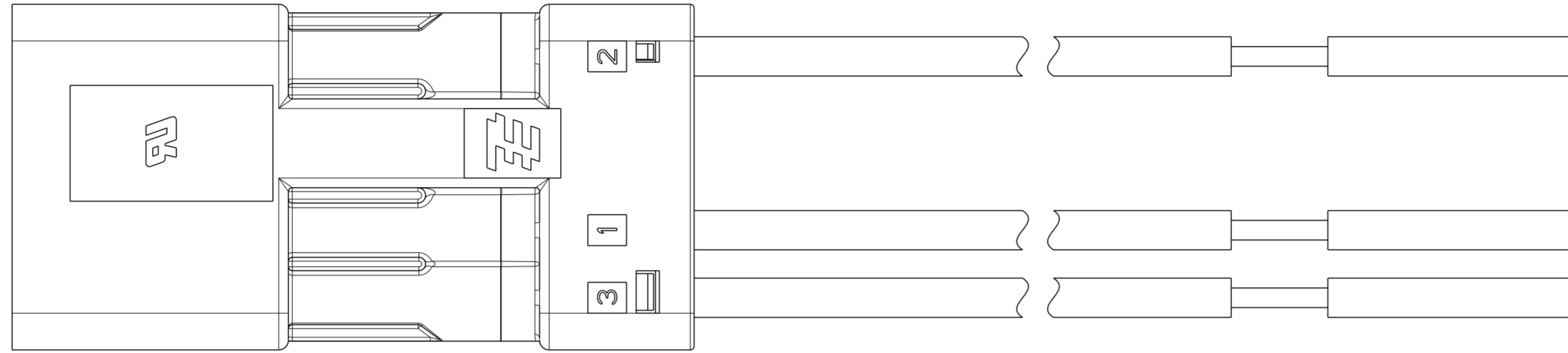

2106391-3, 2106391-6, 2106391-9, 1-2106391-2, 1-2106391-5, 1-2106391-8, 2-2106391-1 and 2-2106391-4 SHOWN

2106391-3 SHOWN
 (SAME AS 2106391-2 EXCEPT 3 POSITION) 

THIS DRAWING IS A CONTROLLED DOCUMENT.		DWN R BROWN 20APR2009	 TE Connectivity	
DIMENSIONS: mm		CHK M MOSTOLLER 20APR2009		
TOLERANCES UNLESS OTHERWISE SPECIFIED:		APVD -	NAME CABLE ASSEMBLY, RECEPTACLE, SLIMSEAL SSL CONNECTOR	
0 PLC ± 1 PLC ±0.2 2 PLC ± 3 PLC ± 4 PLC ± ANGLES ± FINISH		PRODUCT SPEC -	RESTRICTED TO -	
MATERIAL -		APPLICATION SPEC -	SIZE A200779	DRAWING NO C-2106391
-		WEIGHT -	SCALE 4:1	SHEET 2 OF 3 REV H
Customer Drawing				

THIS DRAWING IS UNPUBLISHED. RELEASED FOR PUBLICATION 20
 © COPYRIGHT 20 BY - ALL RIGHTS RESERVED.

LOC		DIST		REVISIONS			
P	LTR	DESCRIPTION	DATE	DWN	APVD		
-	-	SEE SHEET 1	-	-	-		

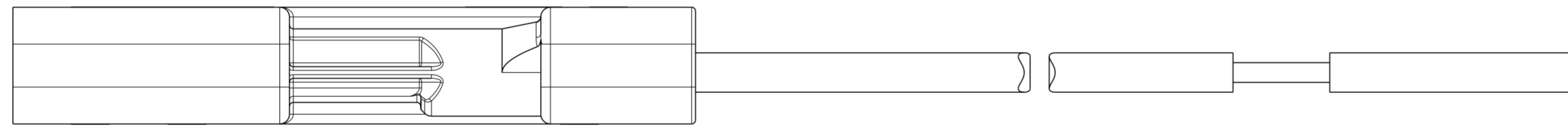
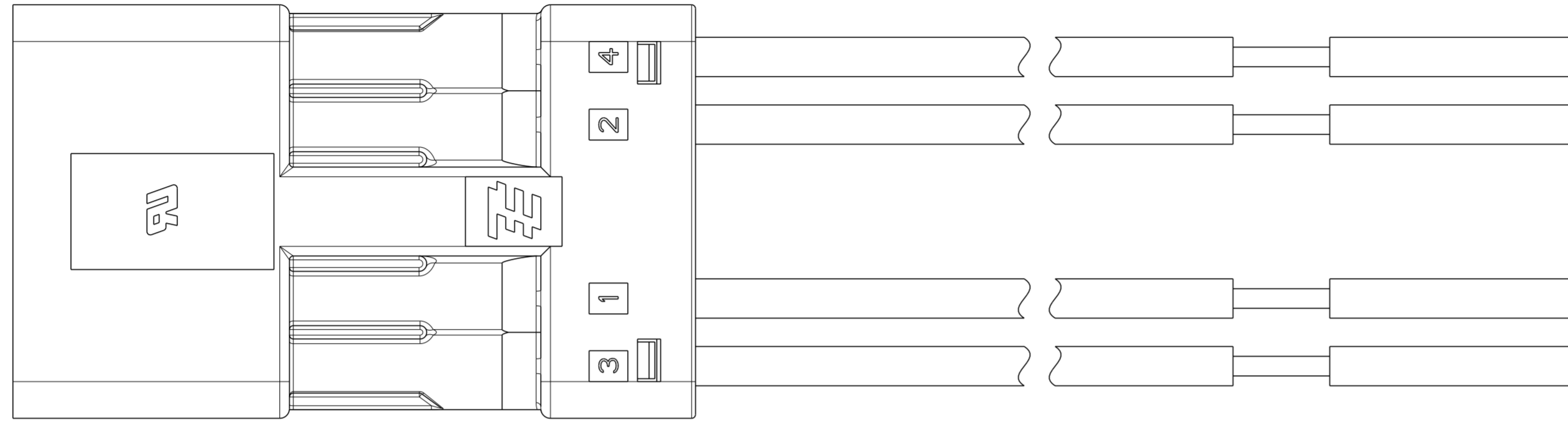

2106391-4, 2106391-7, 1-2106391-0, 1-2106391-3, 1-2106391-6, 1-2106391-9, 2-2106391-2 and 2-2106391-5 SHOWN

2106391-4 SHOWN
 (SAME AS 2106391-2 EXCEPT 4 POSITION) 

THIS DRAWING IS A CONTROLLED DOCUMENT.		DWN R BROWN 20APR2009	 TE Connectivity	
DIMENSIONS: mm		CHK M MOSTOLLER 20APR2009		
TOLERANCES UNLESS OTHERWISE SPECIFIED: 0 PLC ± 1 PLC ±0.2 2 PLC ± 3 PLC ± 4 PLC ± ANGLES ± FINISH		APVD -	NAME CABLE ASSEMBLY, RECEPTACLE, SLIMSEAL SSL CONNECTOR	
MATERIAL -		PRODUCT SPEC -	APPLICATION SPEC -	RESTRICTED TO -
-		WEIGHT -	SIZE A200779	CAGE CODE C-2106391
-		Customer Drawing	SCALE 4:1	SHEET 3 OF 3
-			REV H	



Компания «ЭлектроПласт» предлагает заключение долгосрочных отношений при поставках импортных электронных компонентов на взаимовыгодных условиях!

Наши преимущества:

- Оперативные поставки широкого спектра электронных компонентов отечественного и импортного производства напрямую от производителей и с крупнейших мировых складов;
- Поставка более 17-ти миллионов наименований электронных компонентов;
- Поставка сложных, дефицитных, либо снятых с производства позиций;
- Оперативные сроки поставки под заказ (от 5 рабочих дней);
- Экспресс доставка в любую точку России;
- Техническая поддержка проекта, помощь в подборе аналогов, поставка прототипов;
- Система менеджмента качества сертифицирована по Международному стандарту ISO 9001;
- Лицензия ФСБ на осуществление работ с использованием сведений, составляющих государственную тайну;
- Поставка специализированных компонентов (Xilinx, Altera, Analog Devices, Intersil, Interpoint, Microsemi, Aeroflex, Peregrine, Syfer, Eurofarad, Texas Instrument, Miteq, Cobham, E2V, MA-COM, Hittite, Mini-Circuits, General Dynamics и др.);

Помимо этого, одним из направлений компании «ЭлектроПласт» является направление «Источники питания». Мы предлагаем Вам помощь Конструкторского отдела:

- Подбор оптимального решения, техническое обоснование при выборе компонента;
- Подбор аналогов;
- Консультации по применению компонента;
- Поставка образцов и прототипов;
- Техническая поддержка проекта;
- Защита от снятия компонента с производства.



Как с нами связаться

Телефон: 8 (812) 309 58 32 (многоканальный)

Факс: 8 (812) 320-02-42

Электронная почта: org@eplast1.ru

Адрес: 198099, г. Санкт-Петербург, ул. Калинина, дом 2, корпус 4, литера А.