



Main

Range of product	Zelio Relay
Series name	Power
Product or component type	Plug-in relay
Device short name	RPF
Contacts type and composition	2 C/O
[Uc] control circuit voltage	12 V DC
Control type	Without lockable test button
Shape of pin	Flat
Contacts material	Silver tin oxide
[Ithe] conventional enclosed thermal current	25 Aat -40...131 °F (-40...55 °C)for relays side by side without a gap 30 Aat -40...131 °F (-40...55 °C)for 13 mm gap between two relays
Load current	25 Aat 28 V DC 30 Aat 250 V AC
Utilisation coefficient	10 %

Complementary

Mounting support	DIN rail Panel
Control circuit voltage limits	9.6...13.2 V
[Ie] rated operational current	30 Aat 250 V AC (for NO) conforming to IEC 30 Aat 277 V AC (for NO) conforming to UL 20 Aat 28 V DC (for NO) conforming to UL 3 Aat 250 V AC (for NC) conforming to IEC 3 Aat 28 V DC (for NC) conforming to IEC 3 Aat 277 V AC (for NC) conforming to UL 3 Aat 28 V DC (for NC) conforming to UL 25 Aat 28 V DC (for NO) conforming to IEC
[Ui] rated insulation voltage	250 V conforming to IEC 300 V conforming to UL
[Uimp] rated impulse withstand voltage	4 kV 1.2/50 µs
Maximum switching voltage	250 V conforming to IEC
Maximum switching capacity	7500 VA/700 W
Minimum switching capacity	6000 mW (500 mA/ 12 V)for NO 170 mW (10 mA/ 6 V)for NC
Operating rate	<= 18000 cycles/hour no-load <= 1200 cycles/hour under load
Mechanical durability	5000000 cycles
Electrical durability	100000 cycles resistive load
Average consumption	1.7 W
Drop-out voltage threshold	>= 0.1 Uc
Operating time	25 ms
Reset time	25 ms
Average resistance	86 Ohm (tolerance +/- 10 %)at 68 °F (20 °C)
Safety reliability data	B10d = 100000
Protection category	RT II
Operating position	Any position
Product weight	0.18 lb(US) (0.082 kg)
Device presentation	Complete product

The information provided in this documentation contains general descriptions and/or technical characteristics of the performance of the products contained herein. This documentation is not intended as a substitute for and is not to be used for determining suitability or reliability of these products for specific user applications. It is the duty of any such user or integrator to perform the appropriate and complete risk analysis, evaluation and testing of the products with respect to the relevant specific application or use thereof. Neither Schneider Electric Industries SAS nor any of its affiliates or subsidiaries shall be responsible or liable for misuse of the information contained herein.

Environment

dielectric strength	2000 V AC between poles with basic insulation 1500 V AC between contacts with micro disconnection insulation 4000 V AC between coil and contact with reinforced insulation
standards	EN/IEC 61810-1 UL 508 CSA C22.2 No 14
product certifications	CE CSA GOST UL
ambient air temperature for storage	-40...185 °F (-40...85 °C)
ambient air temperature for operation	-40...131 °F (-40...55 °C)
vibration resistance	3 gn (+/- 1 mm, f = 10...150 Hz) 5 cycles in operation 10 gn (+/- 1 mm, f = 10...150 Hz) 5 cycles not operating
IP degree of protection	IP40 conforming to EN/IEC 60529
shock resistance	10 gn in operation 30 gn not operating
pollution degree	3

Offer Sustainability

Green Premium product	Green Premium product
Compliant - since 0801 - Schneider Electric declaration of conformity	Compliant - since 0801 - Schneider Electric declaration of conformity
Reference not containing SVHC above the threshold	Reference not containing SVHC above the threshold
Available	Available
Need no specific recycling operations	Need no specific recycling operations
WARNING: This product can expose you to chemicals including:	WARNING: This product can expose you to chemicals including:
Nickel compounds, which is known to the State of California to cause cancer, and	Nickel compounds, which is known to the State of California to cause cancer, and
Di-isodecyl phthalate (DIDP), which is known to the State of California to cause birth defects or other reproductive harm.	Di-isodecyl phthalate (DIDP), which is known to the State of California to cause birth defects or other reproductive harm.
For more information go to www.p65warnings.ca.gov	For more information go to www.p65warnings.ca.gov

Contractual warranty

Warranty period	18 months
-----------------	-----------

Dimensions

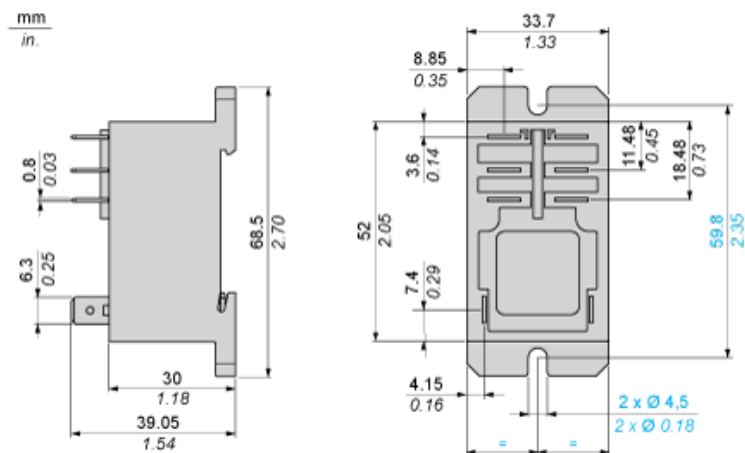

Wiring Diagram

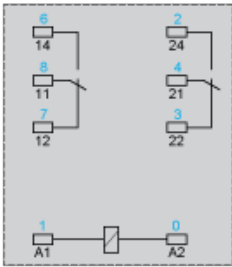

Symbols shown in blue correspond to Nema marking.

Electrical Durability of Contacts

AC Resistive load

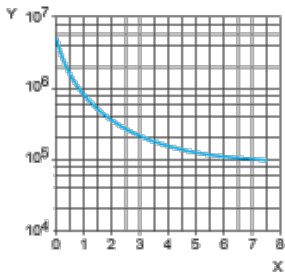

X Switching capacity (kVA)

Y Durability (number of operating cycles)

AC Reduction coefficient for inductive load (depending on power factor $\cos \phi$)

Durability (inductive load) = durability (resistive load) x reduction coefficient.

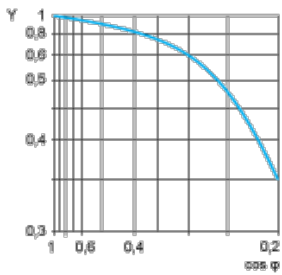

Y reduction coefficient

Maximum switching capacity on DC resistive load

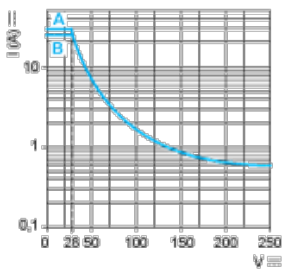

A 30 A

B 25 A

Note : These are typical curves, actual durability depends on load, environment, duty cycle, etc.



Компания «ЭлектроПласт» предлагает заключение долгосрочных отношений при поставках импортных электронных компонентов на взаимовыгодных условиях!

Наши преимущества:

- Оперативные поставки широкого спектра электронных компонентов отечественного и импортного производства напрямую от производителей и с крупнейших мировых складов;
- Поставка более 17-ти миллионов наименований электронных компонентов;
- Поставка сложных, дефицитных, либо снятых с производства позиций;
- Оперативные сроки поставки под заказ (от 5 рабочих дней);
- Экспресс доставка в любую точку России;
- Техническая поддержка проекта, помощь в подборе аналогов, поставка прототипов;
- Система менеджмента качества сертифицирована по Международному стандарту ISO 9001;
- Лицензия ФСБ на осуществление работ с использованием сведений, составляющих государственную тайну;
- Поставка специализированных компонентов (Xilinx, Altera, Analog Devices, Intersil, Interpoint, Microsemi, Aeroflex, Peregrine, Syfer, Eurofarad, Texas Instrument, Miteq, Cobham, E2V, MA-COM, Hittite, Mini-Circuits, General Dynamics и др.);

Помимо этого, одним из направлений компании «ЭлектроПласт» является направление «Источники питания». Мы предлагаем Вам помощь Конструкторского отдела:

- Подбор оптимального решения, техническое обоснование при выборе компонента;
- Подбор аналогов;
- Консультации по применению компонента;
- Поставка образцов и прототипов;
- Техническая поддержка проекта;
- Защита от снятия компонента с производства.



Как с нами связаться

Телефон: 8 (812) 309 58 32 (многоканальный)

Факс: 8 (812) 320-02-42

Электронная почта: org@eplast1.ru

Адрес: 198099, г. Санкт-Петербург, ул. Калинина, дом 2, корпус 4, литера А.