

THIS DRAWING IS UNPUBLISHED. RELEASED FOR PUBLICATION 20
 © COPYRIGHT 20 BY - ALL RIGHTS RESERVED.

REVISIONS					
P	LTR	DESCRIPTION	DATE	DWN	APVD
	DI	REVISED PER ECO-17-018044	22NOV2017	R.L	H.L

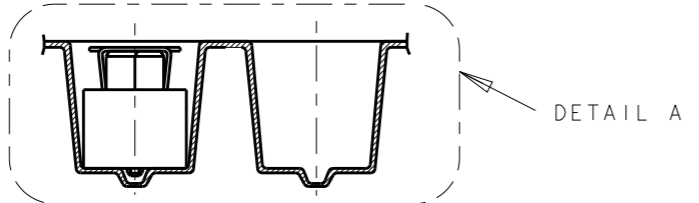

WINDING THE COVER TAPE AROUND THE OUTER PERIPHERY IN A TURN.

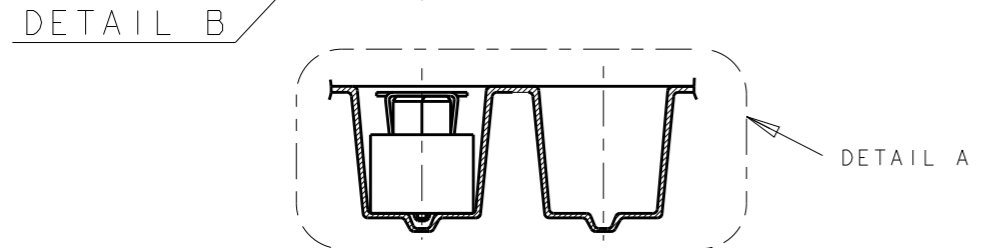
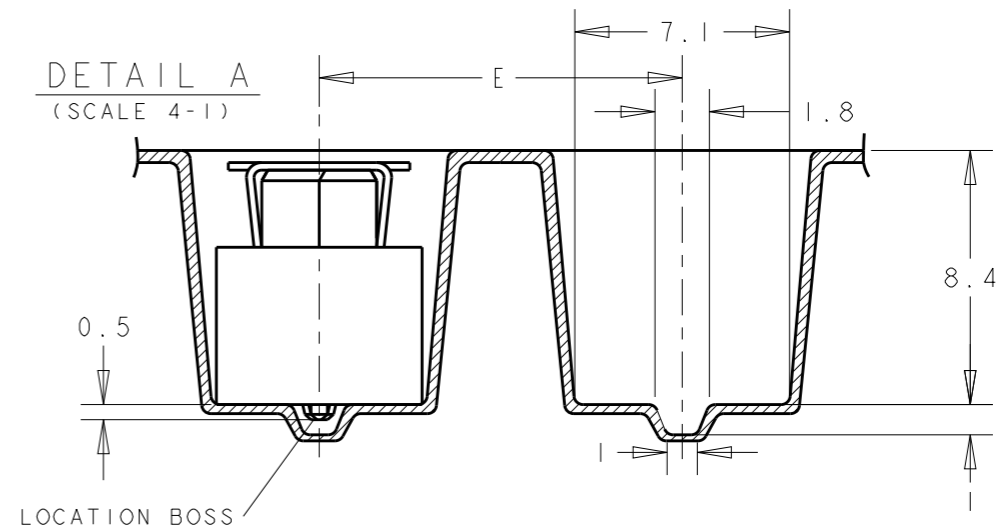
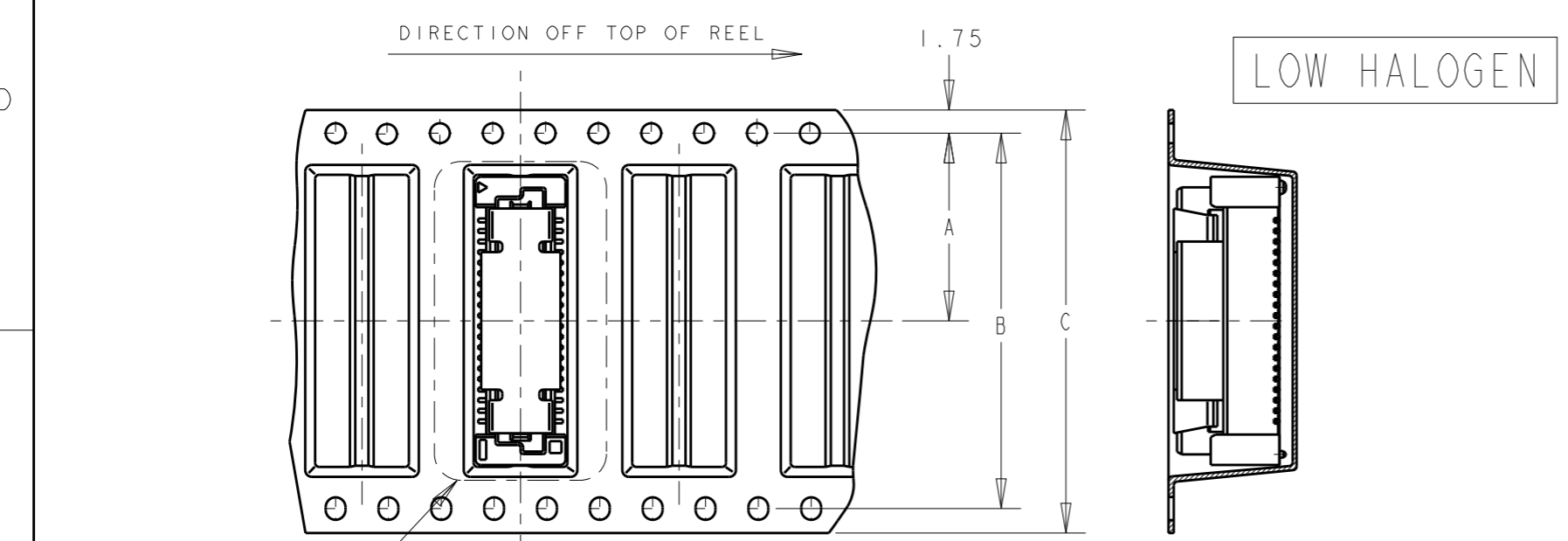
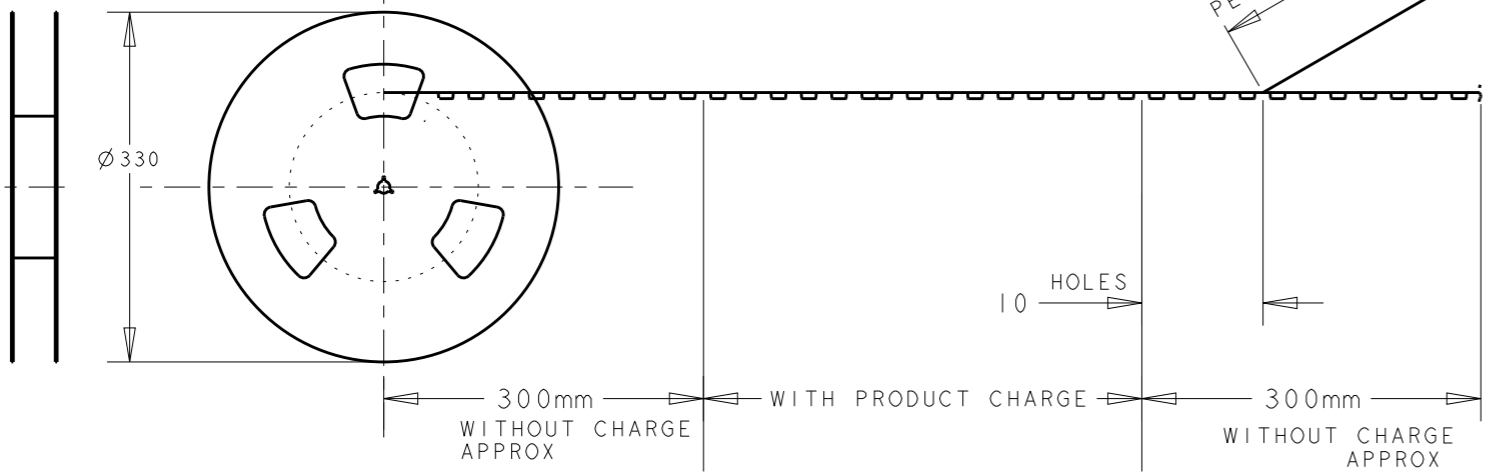

WITH STEEL COVER

STEEL COVER

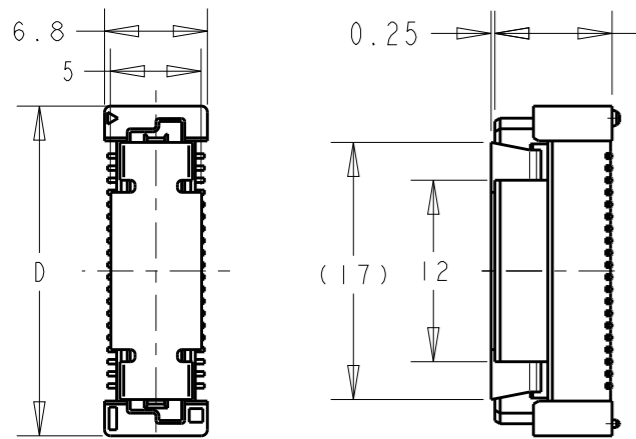

- NOTES:
- 1 0.00076 MIN GOLD PLATING. (30u INCHES GOLD PLATING)
 - 2 0.00020 MIN GOLD PLATING. (Au FLASH PLATING)
 - 3 0.00038 MIN GOLD PLATING. (15u INCHES GOLD PLATING)
 - 4 0.000076 MIN GOLD PLATING (3u INCHES GOLD PLATING)

THIS DRAWING IS A CONTROLLED DOCUMENT.		DWN FLORENCE TAN 14SEP04
DIMENSIONS: mm		CHK ERIC TNG
TOLERANCES UNLESS OTHERWISE SPECIFIED:		APVD SEIFONG
0 PLC ±-	1 PLC ±0.3	PRODUCT SPEC
2 PLC ±0.25	3 PLC ±0.2	APPLICATION SPEC
4 PLC ±-	ANGLES ±3°	WEIGHT
MATERIAL	FINISH	CUSTOMER DRAWING

REMARKS	QTY	E	D	C	B	A	POS	PART NO
4	400	16	45.8	72	68.4	34.2	100	9- -4
	500	12	37.8	56	52.4	26.2	80	9- -3
	500	12	29.8	44	40.4	20.2	60	9- -2
	500	12	21.8	32	28.4	14.2	40	9-5179180-1
1	400	16	61.8	88	84.4	42.2	140	7- -6
	400	16	53.8	72	68.4	34.2	120	7- -5
	400	16	45.8	72	68.4	34.2	100	7- -4
	500	12	37.8	56	52.4	26.2	80	7- -3
2	500	12	29.8	44	40.4	20.2	60	7- -2
	500	12	21.8	32	28.4	14.2	40	7-5179180-1
	400	16	61.8	88	84.4	42.2	140	9- -6
	400	16	61.8	88	84.4	42.2	140	5- -6
3	400	16	53.8	72	68.4	34.2	120	5- -5
	400	16	45.8	72	68.4	34.2	100	5- -4
	500	12	37.8	56	52.4	26.2	80	5- -3
	500	12	29.8	44	40.4	20.2	60	5- -2
9	500	12	21.8	32	28.4	14.2	40	5-5179180-1
	400	16	61.8	88	84.4	42.2	140	3- -6
	400	16	53.8	72	68.4	34.2	120	3- -5
	400	16	45.8	72	68.4	34.2	100	3- -4
3	500	12	37.8	56	52.4	26.2	80	3- -3
	500	12	29.8	44	40.4	20.2	60	3- -2
	500	12	21.8	32	28.4	14.2	40	3-5179180-1

STE TE Connectivity

NAME: REC ASSY'Y 9H TYPE (0.5 BOSS L) FOR FH 0.8mm B-T-B CONN ON TAPING

SIZE: A3 CAGE CODE: 00779 DRAWING NO: C-5179180 RESTRICTED TO: -

SCALE: 2:1 SHEET: 1 OF 3 REV: DI

4

3

2

1

THIS DRAWING IS UNPUBLISHED. RELEASED FOR PUBLICATION 20
 © COPYRIGHT 20 BY - ALL RIGHTS RESERVED.

REVISIONS				
P	LTR	DESCRIPTION	DATE	APVD
		SEE SHEET 1 OF 3		

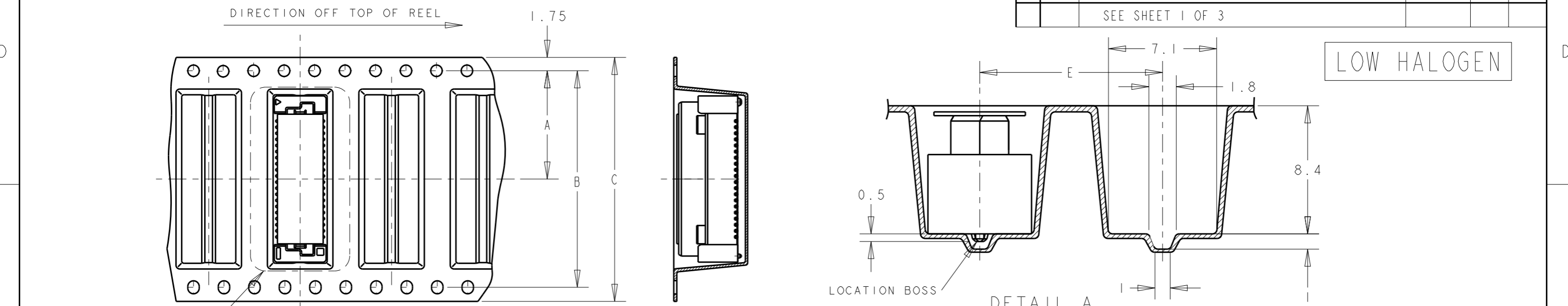

DETAIL B

DETAIL A
(SCALE 4-1)

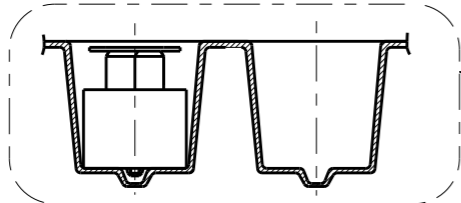

DETAIL A

WINDING THE COVER TAPE
 AROUND THE OUTER
 PERIPHERY IN A TURN.

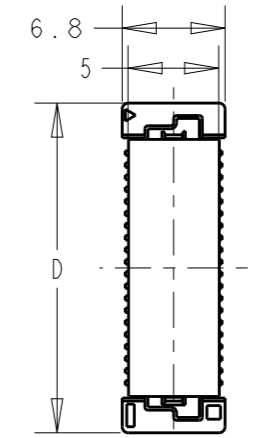
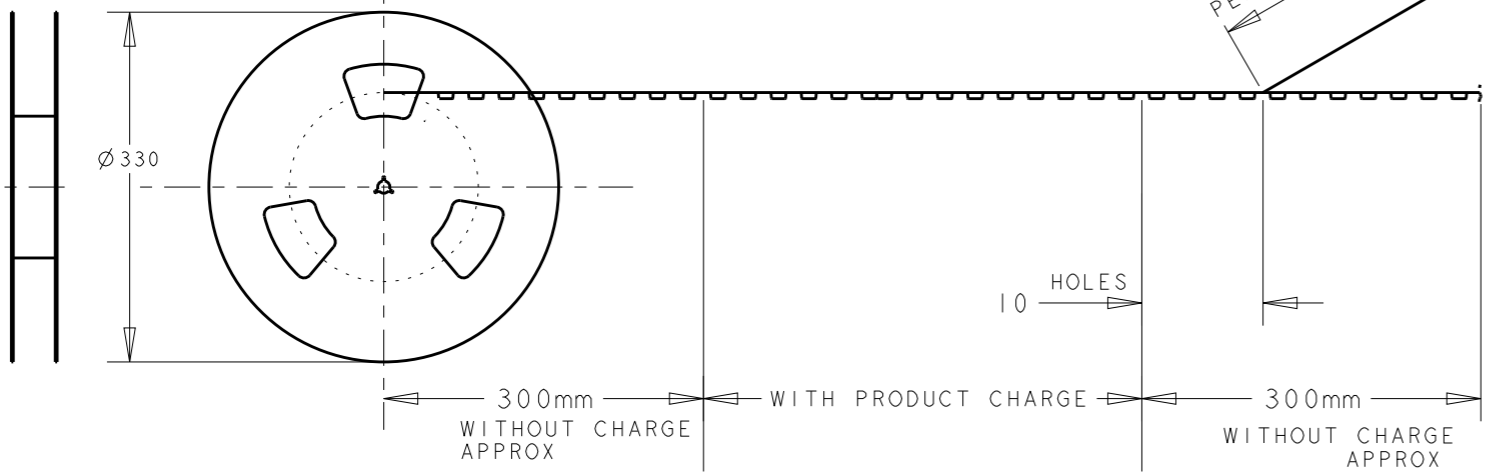

DETAIL B

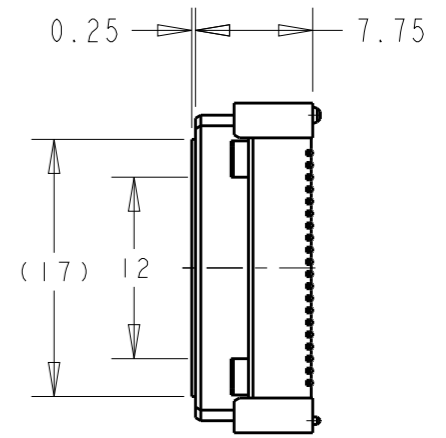

POLYIMIDE COVER

WITH POLYIMIDE COVER

REMARKS	QTY	E	D	C	B	A	POS	PART NO
	400	16	61.8	88	84.4	42.2	140	9-5179180-6

THIS DRAWING IS A CONTROLLED DOCUMENT.		DWN FLORENCE TAN 14SEP04	 TE Connectivity	
DIMENSIONS: mm		CHK ERIC TNG		
TOLERANCES UNLESS OTHERWISE SPECIFIED:		APVD SEIFONG	NAME REC ASSY'Y 9H TYPE (0.5 BOSS L) FOR FH 0.8mm B-T-B CONN ON TAPING	
0 PLC ±0.3		PRODUCT SPEC	SIZE	
1 PLC ±0.25		APPLICATION SPEC	CAGE CODE	
2 PLC ±0.2			DRAWING NO	
3 PLC ±0.2			RESTRICTED TO	
4 PLC ±0.2		WEIGHT	A3 00779 C-5179180	
ANGLES ±3°			SCALE 2:1 SHEET 2 OF 3 REV DI	
FINISH			CUSTOMER DRAWING	

THIS DRAWING IS UNPUBLISHED. RELEASED FOR PUBLICATION 20
 © COPYRIGHT 20 BY - ALL RIGHTS RESERVED.

REVISIONS				
P	LTR	DESCRIPTION	DATE	APVD
		SEE SHEET 1 OF 3		

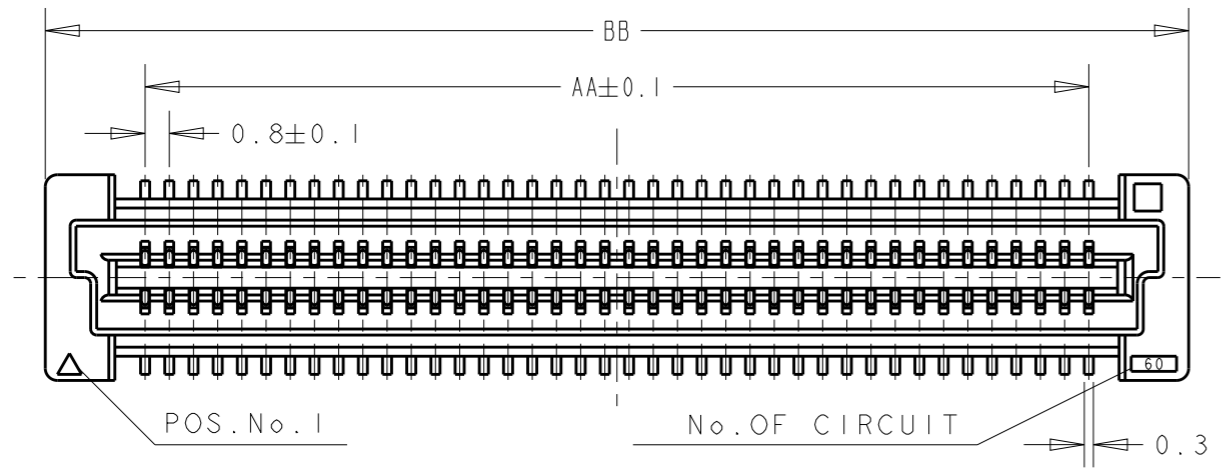

CONNECTOR ONLY

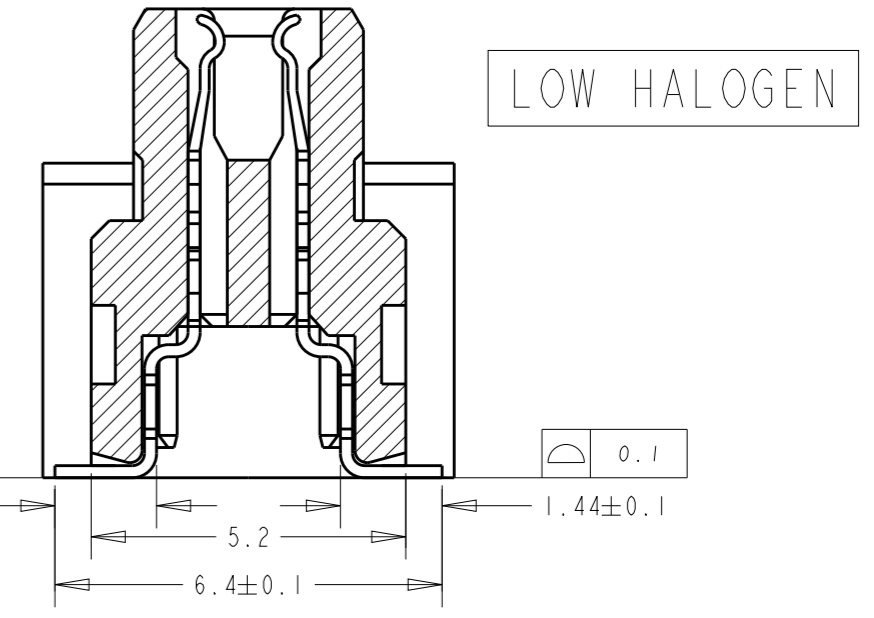

SECT "A" - "A"
(SCALE: 8-1)

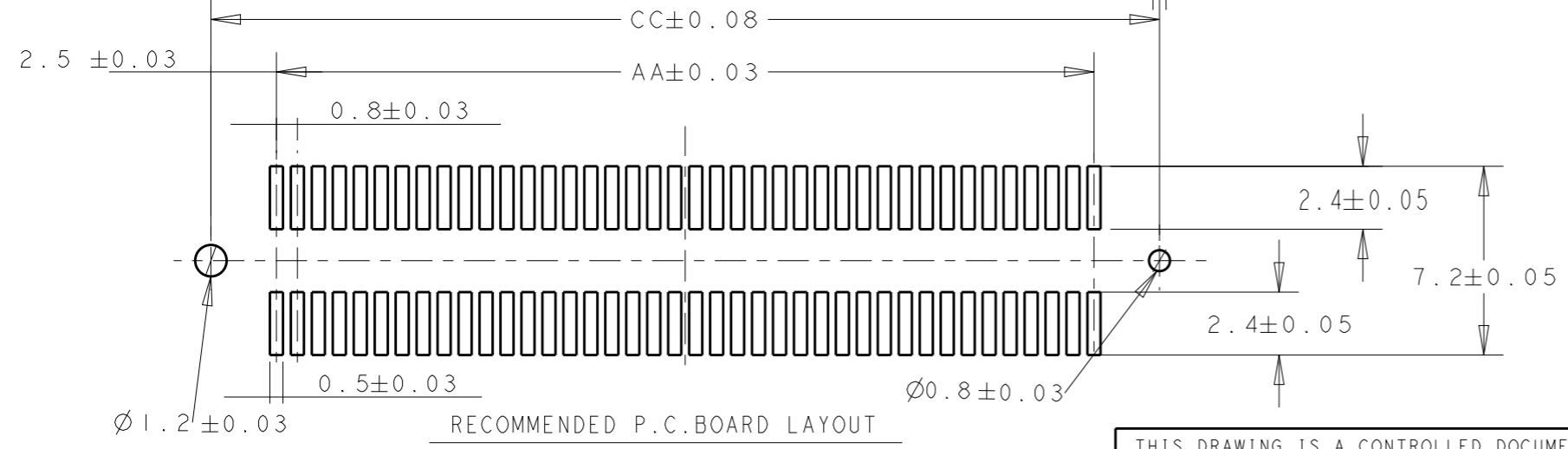
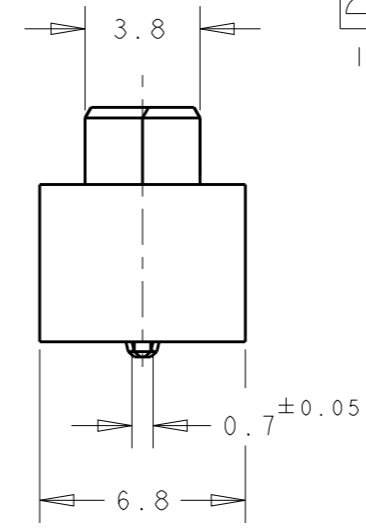
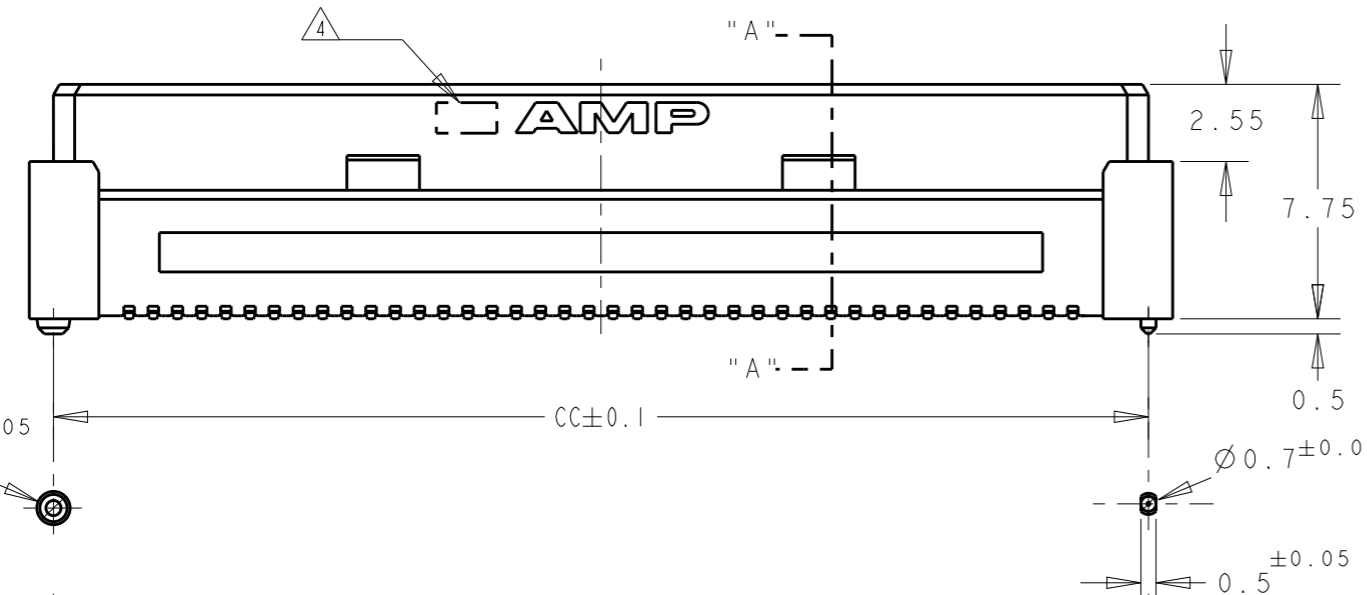

84.20	85.80	79.20	200
76.20	77.80	71.20	180
68.20	69.80	63.20	160
60.20	61.80	55.20	140
52.20	53.80	47.20	120
44.20	45.80	39.20	100
36.20	37.80	31.20	80
28.20	29.80	23.20	60
20.20	21.80	15.20	40
CC	BB	AA	POS.

- NOTES:
- 1 MATERIAL: HOUSING: L.C.P. (HIGH TEMP. THERMOPLASTIC)
UL 94V-0, NATURAL.
CONTACT: BERYLIUM COPPER.
 - 2 FINISH: CONTACT AREA: 0.0002 MIN GOLD ON
0.0013 MIN ALL OVER NICKEL.
SOLDERING AREA: 0.002 MIN MATTE-TIN
 - 3. CONN STACK HEIGHT COMBINE OF PLUG "Y" H VS REC "X" H.
STACK HEIGHT = Y + X - 5
 - 4 MANUFACTURE PLANT LOCATION MARK. QINGDAO:
 - 5 CONNECTOR WITH BLACK HOUSING AND POLYIMIDE COVER

THIS DRAWING IS A CONTROLLED DOCUMENT.	
DIMENSIONS: mm	TOLERANCES UNLESS OTHERWISE SPECIFIED:
	0 PLC ±0.3
	1 PLC ±0.25
	2 PLC ±0.2
	3 PLC ±0.2
	4 PLC ±0.2
	ANGLES ±3°
MATERIAL	FINISH
-	-

DWN	14SEP04
FLORENCE TAN	
CHK	-
ERIC TNG	
APVD	-
SEIFONG	
PRODUCT SPEC	
APPLICATION SPEC	
WEIGHT	-
CUSTOMER DRAWING	



NAME REC ASSY'Y 9H TYPE (0.5 BOSS L) FOR FH 0.8mm B-T-B CONN ON TAPING			
SIZE	CAGE CODE	DRAWING NO	RESTRICTED TO
A3	00779	C=5179180	-
SCALE 2:1		SHEET 3 OF 3	REV D1



Компания «ЭлектроПласт» предлагает заключение долгосрочных отношений при поставках импортных электронных компонентов на взаимовыгодных условиях!

Наши преимущества:

- Оперативные поставки широкого спектра электронных компонентов отечественного и импортного производства напрямую от производителей и с крупнейших мировых складов;
- Поставка более 17-ти миллионов наименований электронных компонентов;
- Поставка сложных, дефицитных, либо снятых с производства позиций;
- Оперативные сроки поставки под заказ (от 5 рабочих дней);
- Экспресс доставка в любую точку России;
- Техническая поддержка проекта, помощь в подборе аналогов, поставка прототипов;
- Система менеджмента качества сертифицирована по Международному стандарту ISO 9001;
- Лицензия ФСБ на осуществление работ с использованием сведений, составляющих государственную тайну;
- Поставка специализированных компонентов (Xilinx, Altera, Analog Devices, Intersil, Interpoint, Microsemi, Aeroflex, Peregrine, Syfer, Eurofarad, Texas Instrument, Miteq, Cobham, E2V, MA-COM, Hittite, Mini-Circuits, General Dynamics и др.);

Помимо этого, одним из направлений компании «ЭлектроПласт» является направление «Источники питания». Мы предлагаем Вам помощь Конструкторского отдела:

- Подбор оптимального решения, техническое обоснование при выборе компонента;
- Подбор аналогов;
- Консультации по применению компонента;
- Поставка образцов и прототипов;
- Техническая поддержка проекта;
- Защита от снятия компонента с производства.



Как с нами связаться

Телефон: 8 (812) 309 58 32 (многоканальный)

Факс: 8 (812) 320-02-42

Электронная почта: org@eplast1.ru

Адрес: 198099, г. Санкт-Петербург, ул. Калинина, дом 2, корпус 4, литера А.