

REVISIONS			
REV	DESCRIPTION, ECN, EAR NO.	DATE	APP'D
B	PROPOSAL DRAWING (EAR 14084)	MAY29/12	K.L.
C	PRODUCT DRAWING (EAR 14091)	JUL24/12	K.L.

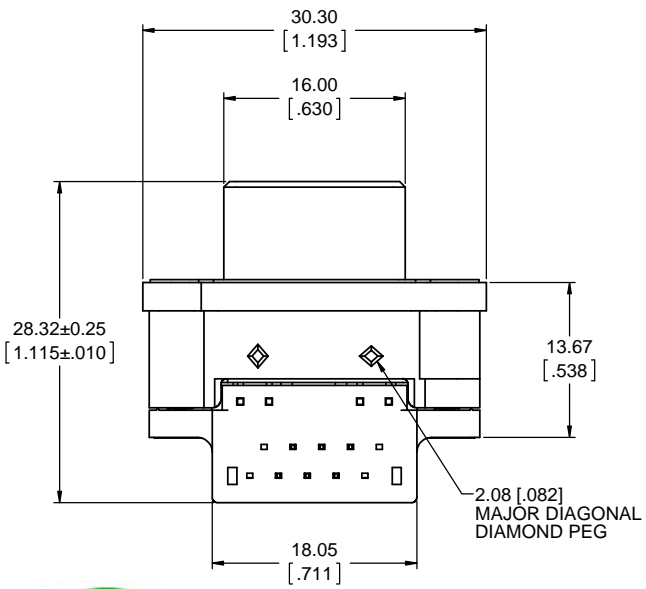
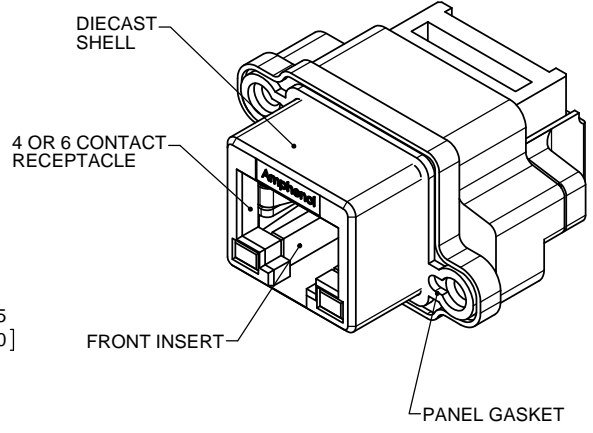
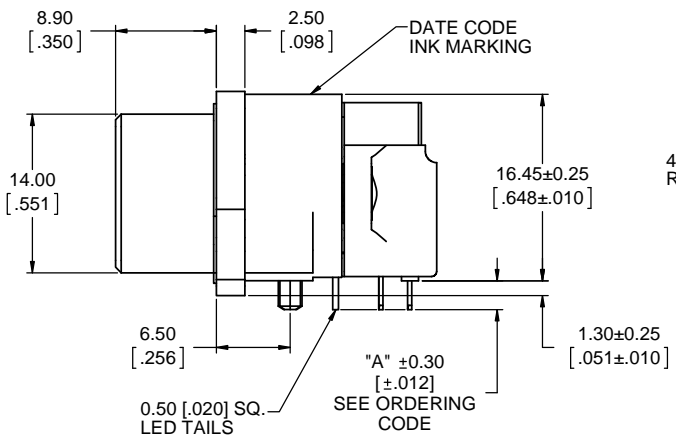
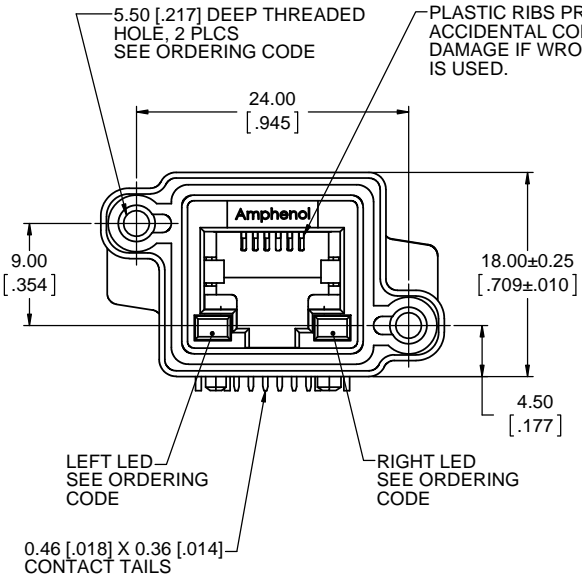

ORDERING CODE: MRJR-33XX-X1

- SERIES RUGGED RJ
- RJ 11 RECEPTACLE, RIGHT ANGLE, PCB TAIL
- NUMBER OF CONTACTS
4 = 4 CONTACTS
6 = 6 CONTACTS
- LED OPTION
0 = NONE
1 = LEFT GREEN, RIGHT YELLOW
4 = LEFT YELLOW, RIGHT GREEN
5 = LEFT GREEN, RIGHT GREEN
- TAIL LENGTH & MOUNTING HOLE THREAD OPTION
0 = "A" 2.54 [1.00], #4-40 UNC
B = "A" 3.81 [1.50], #4-40 UNC
M = "A" 2.54 [1.00], M3 X 0.5
P = "A" 3.81 [1.50], M3 X 0.5
- SINGLE PORT

SPECIAL CONNECTORS
MANY UNIQUE FEATURES ARE READILY AVAILABLE TO SUIT CUSTOMER REQUIREMENTS. CONSULT WITH AMPHENOL CANADA FOR DETAILS.

NOTES:

1. MATERIAL:
ALL MATERIALS ARE RoHS COMPLIANT PER EU DIRECTIVE 2002/95/EC AND AMENDMENTS
 - SHELL - DIECAST ZINC, NICKEL PLATED
 - CONTACTS - PHOSPHOR BRONZE WITH 1.27µm [50 µ"] MIN GOLD OVER 1.27µm [50 µ"] MIN NICKEL ON THE MATING AREA AND MATTE TIN OVER NICKEL ON THE CONTACT TAILS.
 - INSERTS - ENGINEERING THERMOPLASTIC, UL94V-0, REAR INSERTS: BLACK NYLON, FRONT INSERT: CLEAR POLYCARBONATE
 - GASKET - SILICONE RUBBER, CONDUCTIVE, BLACK
 - LED'S - EPOXY LENS, STEEL TAILS WITH TIN PLATING
2. ENVIRONMENTAL PERFORMANCE PER IEC 60529 CODE IP67 FOR SEAL BETWEEN MATING AREA AND PCB SIDE OF CONNECTOR GASKET PROVIDES FOR SEAL TO INSIDE FACE OF PANEL.
3. CURRENT RATING: 1.5 AMPERES
4. CONTACT RESISTANCE: 30 MILLIOHMS MAXIMUM
5. OPERATING TEMPERATURE: -40C TO +105C
6. LED CHARACTERISTICS: FORWARD DC CURRENT 25 mA MAX., FORWARD VOLTAGE 2.5V MAX. @ 2 mA.
7. RECOMMENDED TORQUE FOR PANEL MOUNT SCREWS: 0.45 TO 0.65 N-m (4.0 TO 5.75 IN-LBS) FOR STEEL SCREWS WITH 3.00 (.118) THREAD ENGAGEMENT.
8. CUSTOMER TO VERIFY THAT ALL PROCESS CLEANERS ARE COMPATIBLE WITH POLYCARBONATE MATERIAL.
9. AVAILABLE MATING AREA COVERS PROVIDE ADDED PROTECTON. CONSULT WITH AMPHENOL CANADA FOR DETAILS.



THIS DOCUMENT CONTAINS PROPRIETARY INFORMATION AND SUCH INFORMATION MAY NOT BE DISCLOSED TO OTHERS FOR ANY PURPOSE OR USED FOR MANUFACTURING PURPOSES WITHOUT WRITTEN PERMISSION FROM AMPHENOL CANADA CORP.

UNLESS SPECIFIED OTHERWISE	DRAWN	B.COPPING	MAY29/12
PRIMARY UNITS MILLIMETERS	CHECKED		
SECONDARY INCHES	M.E. APP'D		
REFERENCE IN PARENTHESES	Q.A. APP'D		
GENERAL TOLERANCES	DWG APPR.	K.LAMBIE	MAY29/12
1 DECIMAL PLACE	ENG. REL. NO.	EAR 14084	
2 DECIMAL PLACES ±0.15	REF.		
3 DECIMAL PLACES	THIRD ANGLE PROJECTION		
ANGULAR DEGREES	DO NOT SCALE DRAWING		

Amphenol Canada Corp.
www.amphenolcanada.com

MRJR SERIES MODULAR JACK, 6 POSITION, 4 OR 6 CONTACTS, RIGHT ANGLE PCB TAIL, LED, THREAD & TAIL LENGTH OPTIONS, RoHS COMPLIANT

DWG. NO. **P-MRJR-33XX-X1** REV **C**

CODE ID NO. 03554 DWG SIZE: X SCALE: 3:1 SHEET 1 OF 2

RECOMMENDED PCB LAYOUT
COMPONENT SIDE OF BOARD

REVISIONS			
REV	DESCRIPTION, ECN, EAR NO.	DATE	APP'D
B	PROPOSAL DRAWING (EAR 14084)	MAY29/12	K.L.
C	PRODUCT DRAWING (EAR 14091)	JUL24/12	K.L.

4 POSITION VIEW

LOCATE HOLES
 $\varnothing 0.13[.005]$ DIA
 POSITION DIMENSIONS
 ARE BASIC

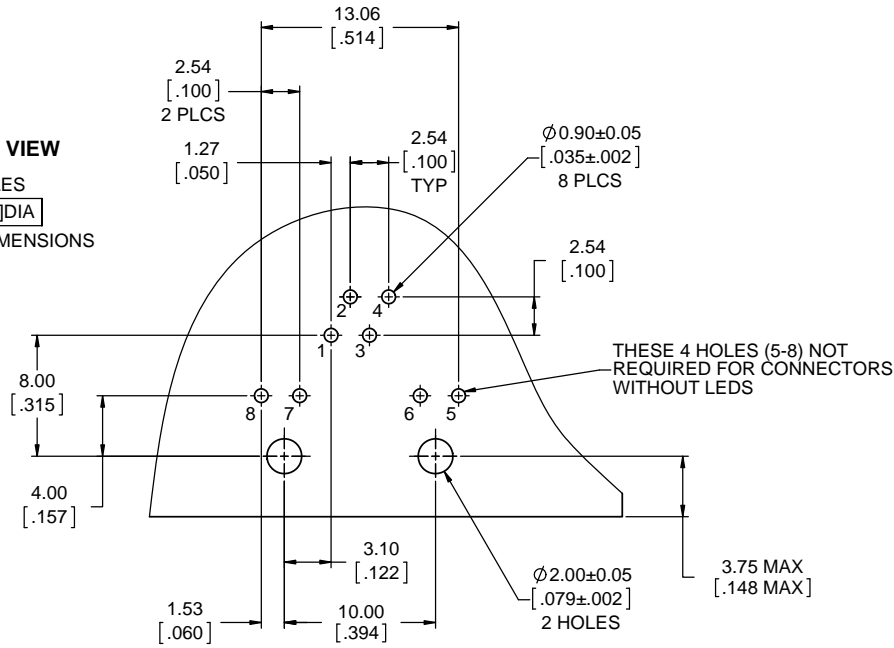

4 POSITION LED SCHEMATIC
GREEN OR YELLOW

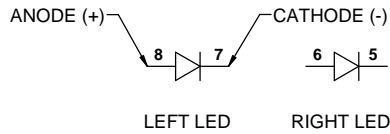

6 POSITION VIEW

LOCATE HOLES
 $\varnothing 0.13[.005]$ DIA
 POSITION DIMENSIONS
 ARE BASIC

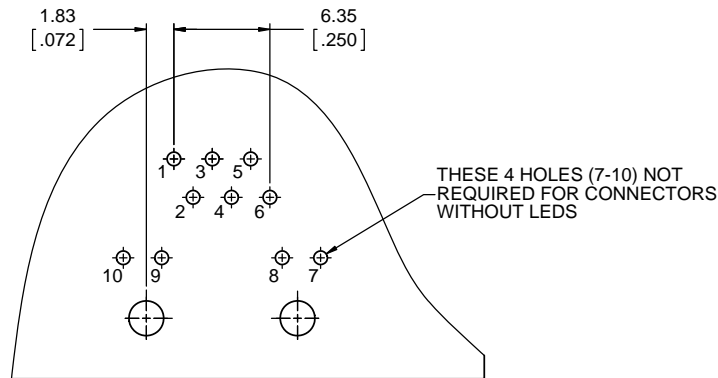

6 POSITION LED SCHEMATIC
GREEN OR YELLOW

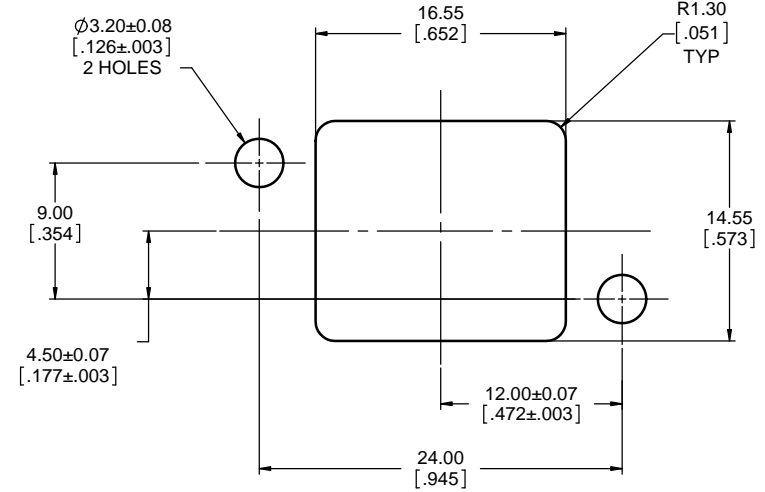
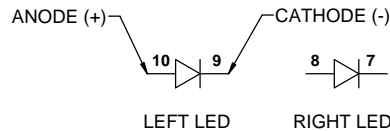

RECOMMENDED PANEL CUTOUT
OUTSIDE PANEL VIEW



UNLESS SPECIFIED OTHERWISE	DRAWN	B.COPPING	MAY29/12
PRIMARY UNITS MILLIMETERS	CHECKED		
SECONDARY UNITS INCHES	M.E. APP'D		
REFERENCE IN PARENTHESES	Q.A. APP'D		
GENERAL TOLERANCES	DWG APPR.	K.LAMBIE	MAY29/12
1 DECIMAL PLACE	ENG. REL. NO.	EAR 14084	
2 DECIMAL PLACES ±0.15	REF.		
3 DECIMAL PLACES	THIRD ANGLE PROJECTION		
ANGULAR DEGREES	DO NOT SCALE DRAWING		

Amphenol Canada Corp.
www.amphenolcanada.com

MRJR SERIES MODULAR JACK,
6 POSITION, 4 OR 6 CONTACTS, RIGHT
ANGLE PCB TAIL, LED, THREAD & TAIL
LENGTH OPTIONS, RoHS COMPLIANT

DWG. NO.	REV
P-MRJR-33XX-X1	C
CODE ID NO. 03554	DWG SIZE: X
SCALE: 5:1	SHEET 2 OF 2



Компания «ЭлектроПласт» предлагает заключение долгосрочных отношений при поставках импортных электронных компонентов на взаимовыгодных условиях!

Наши преимущества:

- Оперативные поставки широкого спектра электронных компонентов отечественного и импортного производства напрямую от производителей и с крупнейших мировых складов;
- Поставка более 17-ти миллионов наименований электронных компонентов;
- Поставка сложных, дефицитных, либо снятых с производства позиций;
- Оперативные сроки поставки под заказ (от 5 рабочих дней);
- Экспресс доставка в любую точку России;
- Техническая поддержка проекта, помощь в подборе аналогов, поставка прототипов;
- Система менеджмента качества сертифицирована по Международному стандарту ISO 9001;
- Лицензия ФСБ на осуществление работ с использованием сведений, составляющих государственную тайну;
- Поставка специализированных компонентов (Xilinx, Altera, Analog Devices, Intersil, Interpoint, Microsemi, Aeroflex, Peregrine, Syfer, Eurofarad, Texas Instrument, Miteq, Cobham, E2V, MA-COM, Hittite, Mini-Circuits, General Dynamics и др.);

Помимо этого, одним из направлений компании «ЭлектроПласт» является направление «Источники питания». Мы предлагаем Вам помощь Конструкторского отдела:

- Подбор оптимального решения, техническое обоснование при выборе компонента;
- Подбор аналогов;
- Консультации по применению компонента;
- Поставка образцов и прототипов;
- Техническая поддержка проекта;
- Защита от снятия компонента с производства.



Как с нами связаться

Телефон: 8 (812) 309 58 32 (многоканальный)

Факс: 8 (812) 320-02-42

Электронная почта: org@eplast1.ru

Адрес: 198099, г. Санкт-Петербург, ул. Калинина, дом 2, корпус 4, литера А.