

Tous droits strictement reserves. Reproduction ou communication a des tiers interdite sous quelque forme que ce soit sans autorisation écrite du propriétaire. Propriete de c FCI. Droits de reproduction FCI.

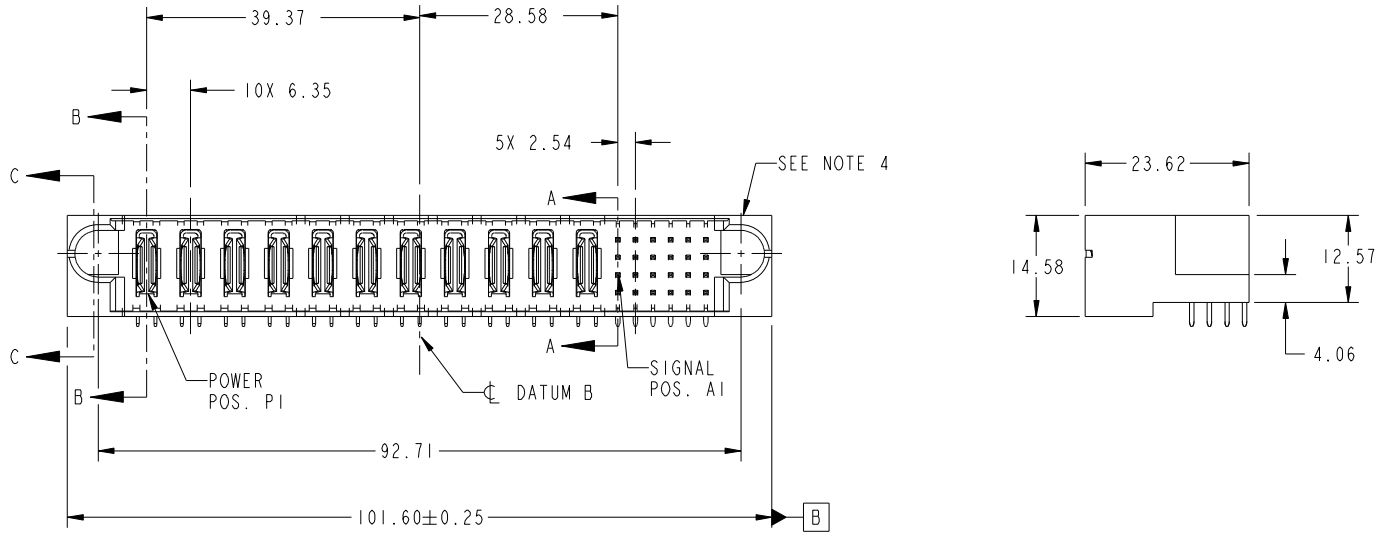

All rights strictly reserved. Reproduction or issue to third parties in any form whatever is not permitted without written authority from the proprietor. Property of FCI. Copyright FCI.

| | | | | | | | | | | | | | | | | | | | | | |
|---------------------------------------|--------------------------|-------|----|----|----|----|----|----|----|----|----|--------|-----|---|---|---|---|----|---|---|--|
| PRODUCT NO. 51732-061... NOTE 3 | ROWS D C B A | POWER | | | | | | | | | | SIGNAL | | | | | | E2 | | | |
| | | E1 | P1 | P2 | P3 | P4 | P5 | P6 | P7 | P8 | P9 | P10 | P11 | 1 | 2 | 3 | 4 | | 5 | 6 | |
| | | | | | | | | | | | | | | | | | | | | | |



| CODE | DIM "M" MATING LENGTH | CONTACT TYPE |
|------|-----------------------|--------------|
| U | [6.86] | SIGNAL |
| T | [6.86] | SIGNAL |
| R | [6.86] | SIGNAL |
| S | [6.86] | SIGNAL |
| PA | [N/A] | POWER |
| H | [5.59] | SIGNAL |
| G | [5.59] | SIGNAL |
| F | [5.59] | SIGNAL |
| E | [5.59] | SIGNAL |

| | | | | | | | | | | | |
|-------------|----------------|----|----------|----------|--------------|---------------------------------------|------------|----------|---|------------------------|--|
| mat'l code | | | | SEE NOTE | | tolerances unless otherwise specified | | CUSTOMER | | www.fciconnect.com | |
| ltr | ecn no. | dr | date | linear | 0.X ±0.3 | | COPY | | title IIP + 24S RIGHT ANGLE SOLDER HEADER | | |
| A | DG10-0226 | SM | 06/10/10 | | 0.XX ±0.13 | | projection | | | | |
| | | | | angles | 0.XXX ±0.051 | | | | product family PwrBlade code 213 | | |
| | | | | | 0° ±2° | | | | | | |
| | | | | dr | Shower Ma | 06/10/10 | scale | | size A 51732-061 sheet 1 of 4 | | |
| | | | | enr | Shower Ma | 06/10/10 | 1:1 | | | | |
| | | | | chr | PM ZHENG | 06/10/10 | | | cage code 22526 | | |
| | | | | appd | JOSEPH HSIA | 06/10/10 | | | | | |
| sheet index | revision sheet | A | A | A | A | A | | | | | |
| | | 1 | 2 | 3 | 4 | | | | | | |

Tous droits strictement reserves. Reproduction ou communication a des tiers interdite sous quelque forme que ce soit sans autorisation écrite du propriétaire. Propriete de c FCI. Droits de reproduction FCI.

All rights strictly reserved. Reproduction or issue to third parties in any form whatever is not permitted without written authority from the proprietor. Property of FCI. Copyright FCI.



PRODUCT NUMBER
51732-061--
NOTE: 3

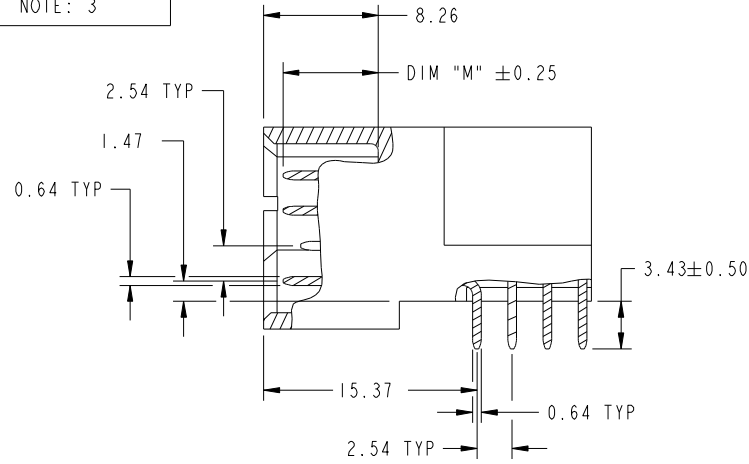

BROKEN-OUT SECTION A-A
SCALE 2:1

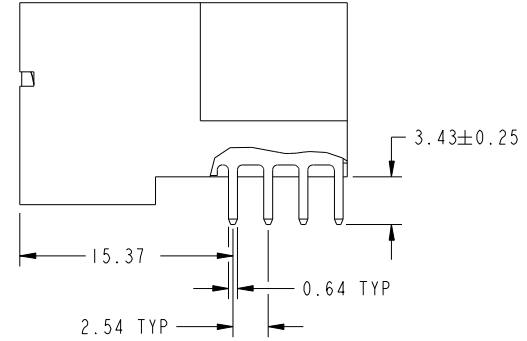

BROKEN-OUT SECTION B-B
SCALE 2:1

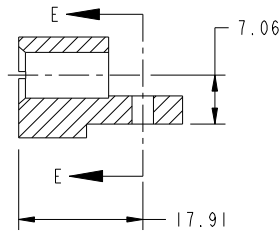

SECTION C-C

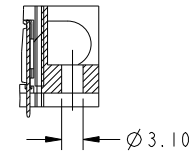

PARTIAL SECTION E-E

| | | | | | | | | | | | |
|-------------|---------|----------------|------|----------|--------------|---------------------------------------|------------|----------|--|----------------|----------|
| mat'l code | | | | SEE NOTE | | tolerances unless otherwise specified | | CUSTOMER | | FCI | |
| ltr | ecn no. | dr | date | linear | 0.X ±0.3 | | COPY | | www.fciconnect.com | | |
| A | | | | | 0.XX ±0.13 | | projection | | title | | |
| | | | | | 0.XXX ±0.051 | | | | 11P + 24S RIGHT ANGLE SOLDER HEADER | | |
| | | | | | angles | 0° ±2° | | | | product family | PwrBlade |
| | | | | dr | Shower Ma | 06/10/10 | scale | | size | dwg no | 213 |
| | | | | enr | Shower Ma | 06/10/10 | 1:1 | | A | 51732-061 | sheet |
| | | | | chr | PM ZHENG | 06/10/10 | | | 2 of 4 | | |
| | | | | appd | JOSEPH HSIA | 06/10/10 | | | | | |
| sheet index | | revision sheet | | | | | | | | | |

cage code 22526

Pro/E

Tous droits strictement reserves. Reproduction ou communication a des tiers interdite sous quelque forme que ce soit sans autorisation écrite du propriétaire. Propriete de c FCI. Droits de reproduction FCI.



All rights strictly reserved. Reproduction or issue to third parties in any form whatever is not permitted without written authority from the proprietor. Property of FCI. Copyright FCI.

PRODUCT NUMBER
51732-061--
NOTE: 3

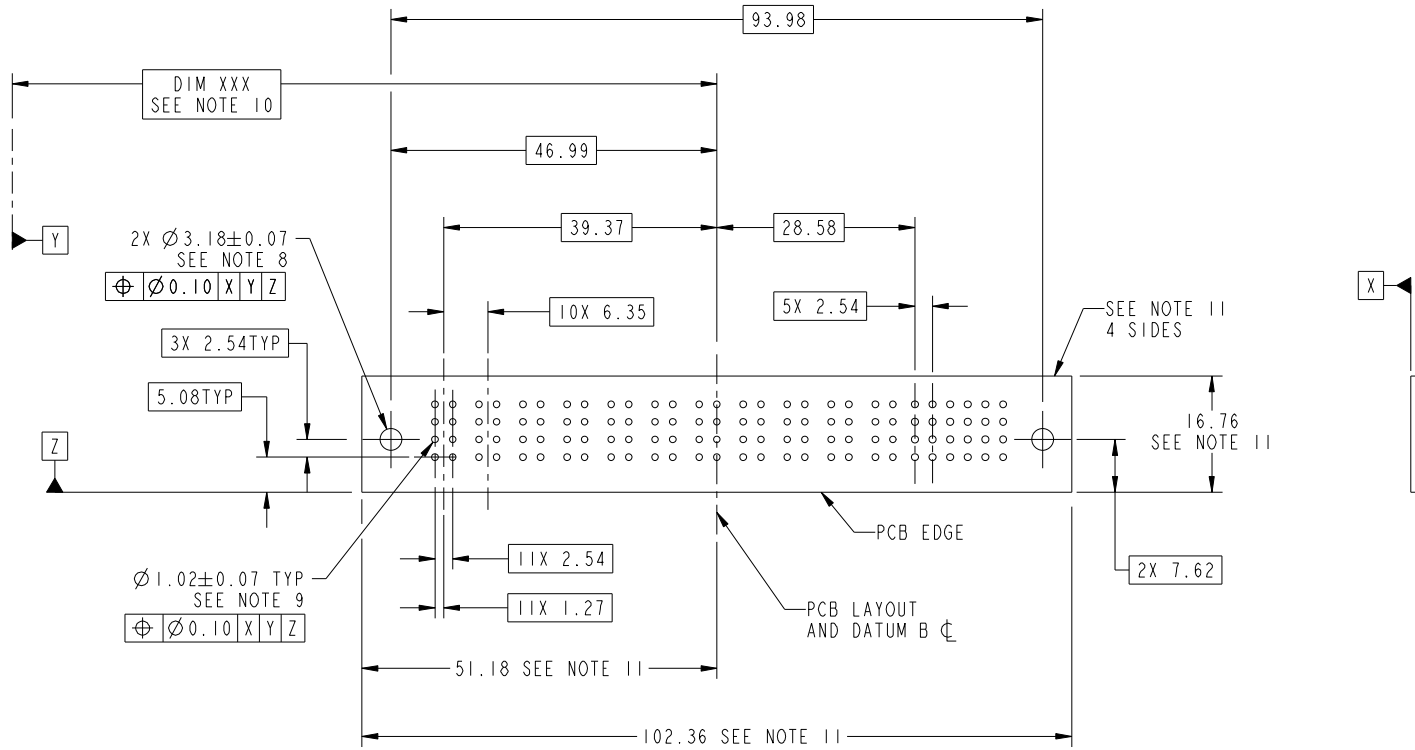

RECOMMENDED PCB LAYOUT

| | | | | | | | | | |
|-------------|---------|----------------|------|---------------------------------------|----------------------|------------|--|--|--|
| mat'l code | | SEE NOTE | | tolerances unless otherwise specified | | CUSTOMER | | FCI | |
| ltr | ecn no. | dr | date | linear | 0.X ±0.3 | COPY | | www.fciconnect.com | |
| A | | | | | 0.XX ±0.13 | projection | | title | |
| | | | | angles | 0.XXX ±0.051 | | | 11P + 24S RIGHT ANGLE SOLDER HEADER | |
| | | | | dr | Shower Ma 06/10/10 | MIM | | product family PwrBlade code | |
| | | | | enr | Shower Ma 06/10/10 | | | size 213 | |
| | | | | chr | PM ZHENG 06/10/10 | scale | | dwg no 51732-061 sheet | |
| | | | | appd | JOSEPH HSIA 06/10/10 | 1:1 | | 3 of 4 | |
| sheet index | | revision sheet | | | | | | | |

cage code 22526

Pro/E

Tous droits strictement reserves. Reproduction ou communication a des tiers interdite sous quelque forme que ce soit sans autorisation écrite du propriétaire. Propriete de c FCI. Droits de reproduction FCI.



All rights strictly reserved. Reproduction or issue to third parties in any form whatever is not permitted without written authority from the proprietor. Property of FCI. Copyright FCI.

PRODUCT NUMBER
51732-061--
NOTE: 3

NOTES:

1. DIMENSIONS AND TOLERANCES ARE IN ACCORDANCE WITH ASME Y14.5M, 1994 UNLESS OTHERWISE SPECIFIED.

CONNECTOR NOTES:

- 2. HOUSING MATERIAL: UL 94 V-0 GLASS FILLED
HIGH-TEMP THERMOPLASTIC
POWER CONTACT MATERIAL: COPPER ALLOY
SIGNAL PIN MATERIAL: COPPER ALLOY
- 3. SEE ITEM 1 & 2 IN PRINT 10064183 FOR PLATING SPEC OF 51732-061 AND (16:51732-061LF RESPECTIVELY.
- 4. MANUFACTURER'S NAME, P/N, AND DATE CODE TO APPEAR ON THIS SURFACE.
- 5. PRODUCT SPECIFICATION GS-12-149.
APPLICATION SPECIFICATION BUS-20-067.
- 6. PACKAGED IN TRAYS.

PCB NOTES:

- 7. ALL HOLE DIAMETERS ARE FINISHED HOLE SIZE.
- 8. MOUNTING HOLES, WHERE APPLICABLE, ARE UNPLATED.
- 9. $\varnothing 1.151 \pm 0.025$ DRILLED HOLES PLATED WITH
0.008 MIN SnPb OR Sn OVER 0.03
TO 0.08 Cu PLATING TO ACHIEVE
 $\varnothing 1.02 \pm .07$ HOLE.
- 10. "DIM XXX" TO BE DETERMINED BY THE CUSTOMER.
- 11. CONNECTOR KEEP-OUT ZONE.

| | | | | | | | | | | | | |
|-------------|---------|----------------|------|---------------------------------------|----------------------|------------|--|----------------|--|---------------------------|--------|--|
| mat'l code | | SEE NOTE | | tolerances unless otherwise specified | | CUSTOMER | | FCI | | www.fciconnect.com | | |
| ltr | ecr no. | dr | date | linear | 0.X ± 0.3 | COPY | | | | title | | |
| A | | | | | 0.XX ± 0.13 | projection | | | | IIP + 24S | | |
| | | | | angles | 0.XXX ± 0.051 | | | | | RIGHT ANGLE SOLDER HEADER | | |
| | | | | dr | Shower Ma 06/10/10 | MIM | | product family | | PwrBlade | code | |
| | | | | engr | Shower Ma 06/10/10 | | | size | | dwg no | 213 | |
| | | | | chr | PM ZHENG 06/10/10 | scale | | A | | 51732-061 | sheet | |
| | | | | appd | JOSEPH HSIA 06/10/10 | 1:1 | | | | | 4 of 4 | |
| sheet index | | revision sheet | | | | | | | | | | |

cage code 22526

Pro/E



Компания «ЭлектроПласт» предлагает заключение долгосрочных отношений при поставках импортных электронных компонентов на взаимовыгодных условиях!

Наши преимущества:

- Оперативные поставки широкого спектра электронных компонентов отечественного и импортного производства напрямую от производителей и с крупнейших мировых складов;
- Поставка более 17-ти миллионов наименований электронных компонентов;
- Поставка сложных, дефицитных, либо снятых с производства позиций;
- Оперативные сроки поставки под заказ (от 5 рабочих дней);
- Экспресс доставка в любую точку России;
- Техническая поддержка проекта, помощь в подборе аналогов, поставка прототипов;
- Система менеджмента качества сертифицирована по Международному стандарту ISO 9001;
- Лицензия ФСБ на осуществление работ с использованием сведений, составляющих государственную тайну;
- Поставка специализированных компонентов (Xilinx, Altera, Analog Devices, Intersil, Interpoint, Microsemi, Aeroflex, Peregrine, Syfer, Eurofarad, Texas Instrument, Miteq, Cobham, E2V, MA-COM, Hittite, Mini-Circuits, General Dynamics и др.);

Помимо этого, одним из направлений компании «ЭлектроПласт» является направление «Источники питания». Мы предлагаем Вам помощь Конструкторского отдела:

- Подбор оптимального решения, техническое обоснование при выборе компонента;
- Подбор аналогов;
- Консультации по применению компонента;
- Поставка образцов и прототипов;
- Техническая поддержка проекта;
- Защита от снятия компонента с производства.



Как с нами связаться

Телефон: 8 (812) 309 58 32 (многоканальный)

Факс: 8 (812) 320-02-42

Электронная почта: org@eplast1.ru

Адрес: 198099, г. Санкт-Петербург, ул. Калинина, дом 2, корпус 4, литера А.