

### SAM C20 QTouch Robustness Demo

#### USER GUIDE

## Description

The Atmel® | SMART SAM C20 QTouch® Robustness Demo demonstrates the high performance capacitive touch support of the Peripheral Touch Controller (PTC) while achieving best-in-class conducted immunity and moisture tolerance. The demo implements a robust solution that allows customers to easily incorporate the Atmel QTouch technology into designs that require a high level of noise immunity and moisture tolerance.

## Features

- Four self-capacitance buttons with Philipp Spring
- One self-capacitance slider using six Philipp Spring
- One seven segment LED to display slider position
- Buzzer for audio feedback
- On-board Embedded Debugger module for programming/debugging and QDebug data streaming
- Connectivity with the Atmel QTouch Analyzer



## Table of Contents

---

Description.....	1
Features.....	1
1. Overview.....	4
2. Hardware Description.....	5
2.1. Block Diagram .....	5
3. Pin Configuration.....	6
3.1. Self Capacitance.....	6
3.2. Indication.....	6
3.3. Communication Interface.....	7
4. Unit Assembly.....	8
5. Powering Up the Kit.....	9
6. Embedded Debugger (EDBG).....	10
7. Connecting to QTouch Analyzer.....	12
8. Switch Operation.....	14
8.1. Noise Handling.....	14
8.2. Moisture Tolerance.....	14
9. Board Operation.....	15
9.1. Product Layout.....	15
9.2. Lock Button.....	15
9.3. Button Description.....	15
9.3.1. Minus Button.....	15
9.3.2. Plus Button.....	15
9.3.3. Power Button.....	16
9.3.4. Slider Sensors.....	16
10. Operating Modes of the Kit.....	17
10.1. Application Flow.....	17
10.2. Normal Mode.....	17
10.3. Mode Change.....	18
10.4. Settings Mode.....	18
10.4.1. Buzzer Volume Adjustment.....	18
11. Schematic.....	20
12. PCB Design.....	22
13. Bill of Materials.....	23

14. Reference.....	25
15. Revision History.....	26

## 1. Overview

This document describes the SAM C20 QTouch Robustness demo kit. The demo kit demonstrates self capacitance button and slider implemented using Philipp springs. The associated package for SAM C20 QTouch Robustness Demo contains schematics, Gerber, BoM, and firmware.

The demo kit consists of a base board and a front panel. The front panel is mechanically fixed on the base board by using plastic spacers.

The demo kit is designed to be used as a standalone unit with its own on-board microcontroller to evaluate the noise immunity and moisture tolerance performance. The SAM C20 QTouch Robustness demo kit running its associated firmware can pass Test Level 3 (10Vrms) of IEC/EN 61000-4-6 specification for conducted immunity.

**Figure 1-1 Internal View of the Demo Kit**



## 2. Hardware Description

### 2.1. Block Diagram

Figure 2-1 Block Diagram of SAM C20 QTouch Robustness Demo Kit

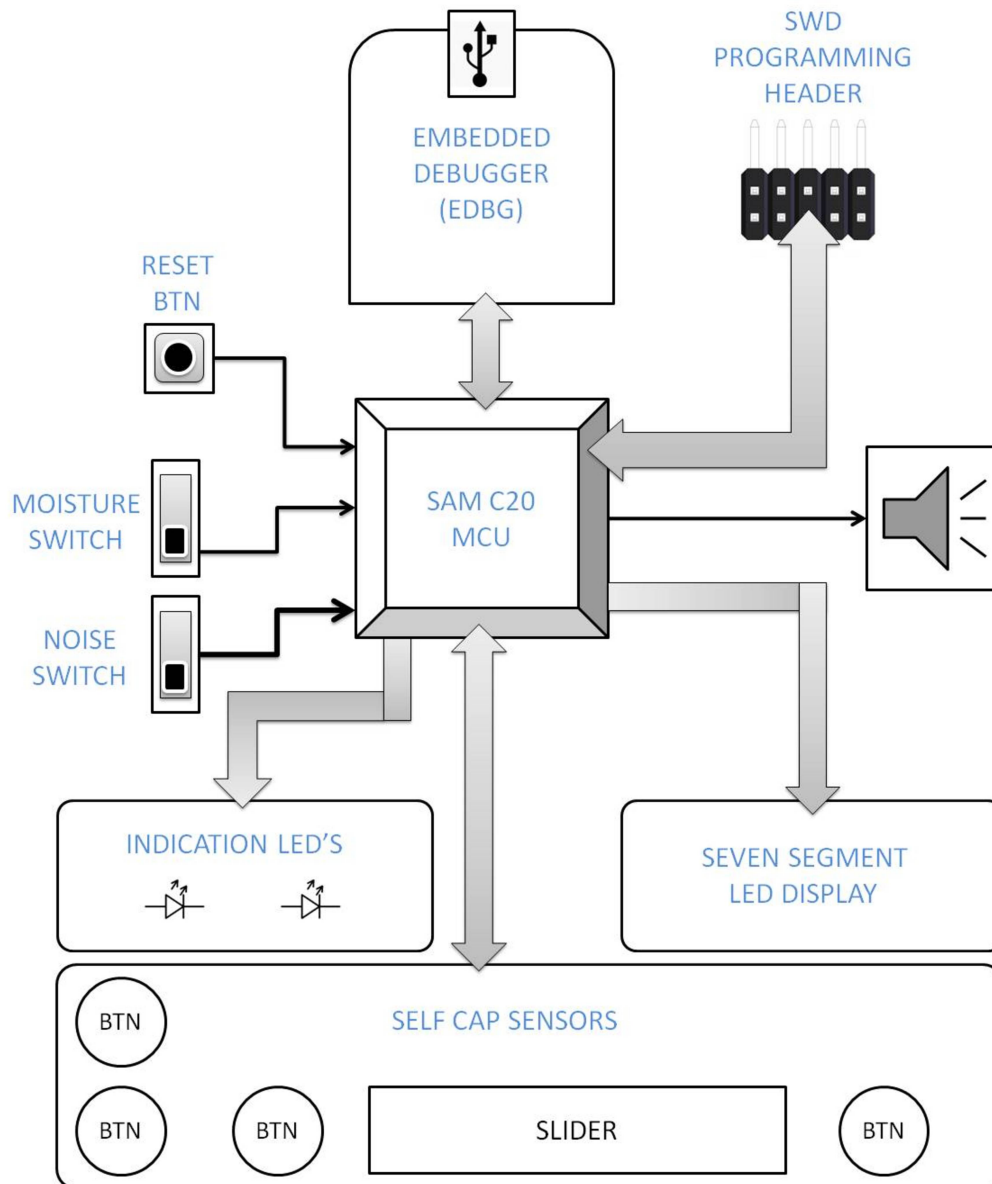

## 3. Pin Configuration

### 3.1. Self Capacitance

The demo kit has one slider and four touch buttons, which are based on self-capacitance technology. There are ten Y-lines used. The slider is composed of six channels. Six individual buttons are arranged in the format of slider. Philipp Spring is used to bridge the air gap between the PCB and front panel. The Philipp Spring design is patented by Atmel and design specifications of the Philipp Springs can be obtained from Atmel.

**Table 3-1 Pin Configuration of the Self Capacitance Sensors**

FUNCTIONALITY	MCU PIN	MCU PIN NAME
Y1	4	PA03
Y14	7	PB08
Y15	8	PB09
Y2	9	PA04
Y3	10	PA05
Y5	12	PA07
Y16	13	PA08
Y17	14	PA09
Y8	47	PB02
Y9	48	PB03

### 3.2. Indication

This demo kit has one seven segment LED display, one buzzer for touch detection, and two LEDs to indicate ON/OFF status of Power and Lock buttons.

**Table 3-2 Pin Configuration of LEDs and Buzzer**

FUNCTIONALITY	MCU PIN	MCU PIN NAME
LEDSEG1	25	PA16
LEDSEG2	26	PA17
LEDSEG3	27	PA18
LEDSEG4	28	PA19
LEDSEG5	29	PA20
LEDSEG6	30	PA21
LEDSEG7	31	PA22
LEDSEG8	32	PA23
LEDQT1	33	PA24

FUNCTIONALITY	MCU PIN	MCU PIN NAME
LEDQT2	34	PA25
BUZZ-TC01	20	PB11

### 3.3. Communication Interface

The communication pins of the Touch MCU are connected to the Data Gateway Interface (DGI) of the Embedded Debugger (EDBG) module through the level converter that acts as a bridge between PC and SAM C20 MCU. Touch data is sent by using the Bit Bang SPI mode.

**Table 3-3 Pin Configuration for Bit Bang SPI Communication Interface**

FUNCTIONALITY	MCU PIN	MCU PIN NAME
DBG_MOSI	21	PA12
DBG_SCK	22	PA13
DBG_SS	23	PA14
DBG_MISO	24	PA15

## 4. Unit Assembly

There are two separate units for the demo kit:

- Acrylic Front Panel
- Base PCB

**Figure 4-1 Board Stack-up**





## 5. Powering Up the Kit

The demo kit can be powered either by using USB connected to the EDBG module or by using an external +5V supply. There are multiple components in the kit which can handle different voltage ratings. The SAM C20 is working in +5V for better noise immunity. The maximum safe operating rate of the SAM C20 is +5.5V. The LEDs are driven at +3.3V by default to ensure optimum brightness. +3.3V for LEDs and other components are supplied from the regulator on the EDBG module. LED also has an option for +5V operation by using jumper selection.

## 6. Embedded Debugger (EDBG)

The demo kit features an on-board Embedded Debugger (EDBG) module. This can be used for programming and debugging the firmware using Atmel Studio. Additionally, it allows to stream touch data between the host PC and the kit using the Data Gateway Interface (DGI).

Figure 6-1 EDBG on SAM C20 QTouch Robustness Demo Kit



The EDBG is mounted on the kit as a separate module. Using the EDBG the user can connect to a QTouch Analyzer and view the touch data. The EDBG has been pre-configured to support a SAMC20G18 device using SWD interface for programming and debugging. For streaming data to the QTouch Analyzer it uses DGI, which connects to SAM C20 over Bit Bang SPI.

Figure 6-2 Connecting with EDBG for Programming using Atmel Studio

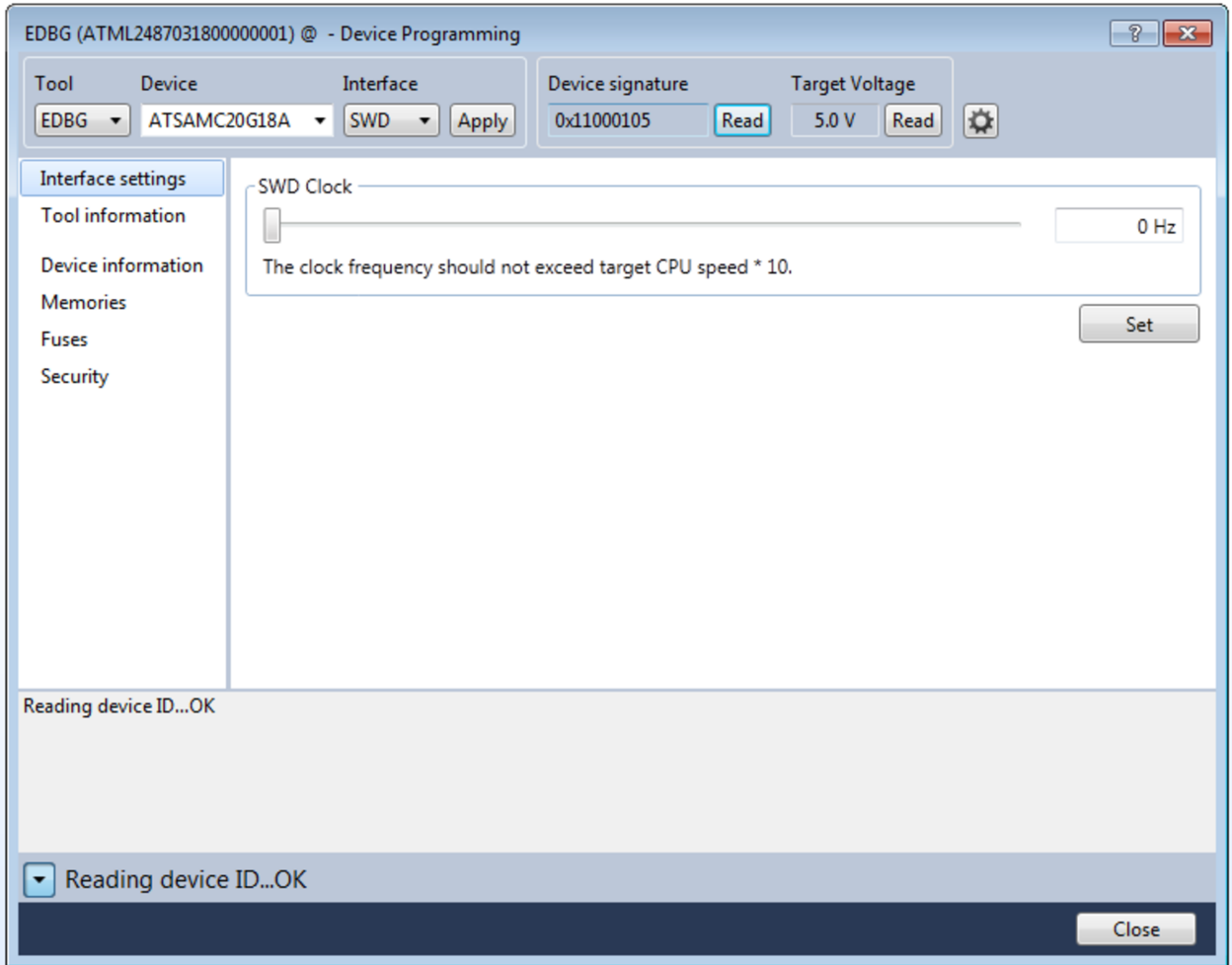

## 7. Connecting to QTouch Analyzer

Follow the steps below to connect the QTouch Analyzer to view touch data.

1. Connect the kit to PC using an mini USB cable.
2. Open QTouch Analyzer in Atmel Studio 6.
3. Select QDEBUG\_DGI from the drop down menu and click on **Connect**.

**Figure 7-1 Select QDEBUG\_DGI**

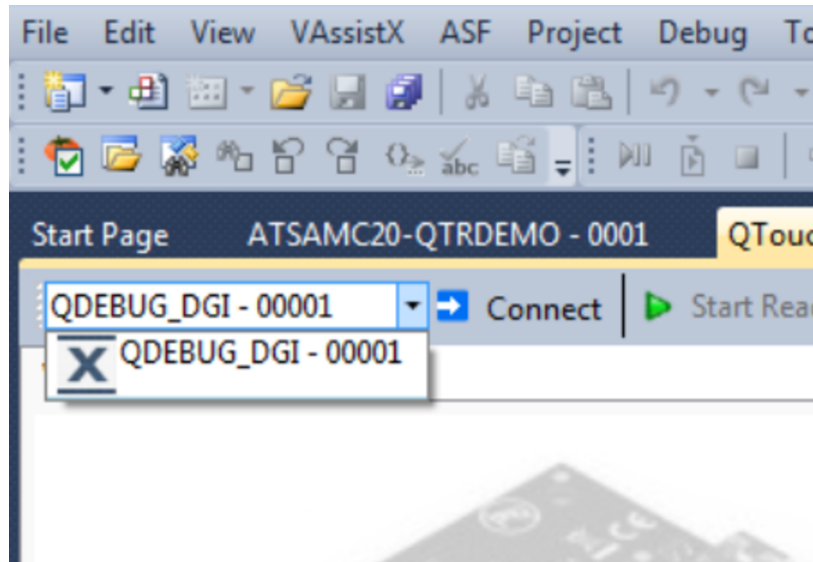

4. Click **OK** when the DGI settings screen pops up.

**Figure 7-2 DGI Settings Screen Pops Up**

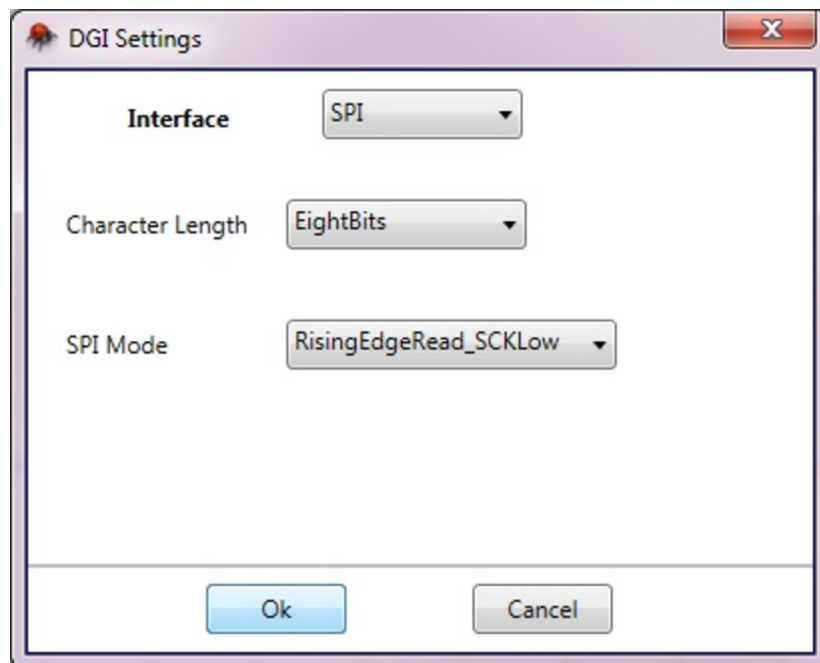

5. Click **Start Reading**.

Figure 7-3 Capturing Touch Signal

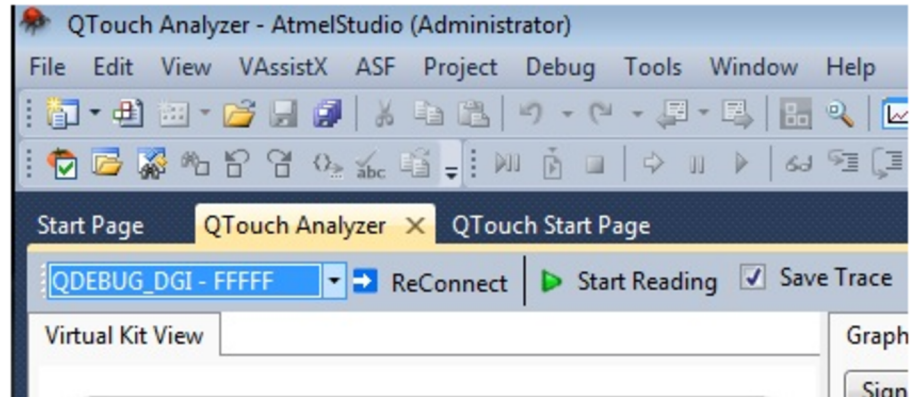

6. View the touch signal in the QTouch Analyzer.

Figure 7-4 Touch Signal View in QTouch Analyzer

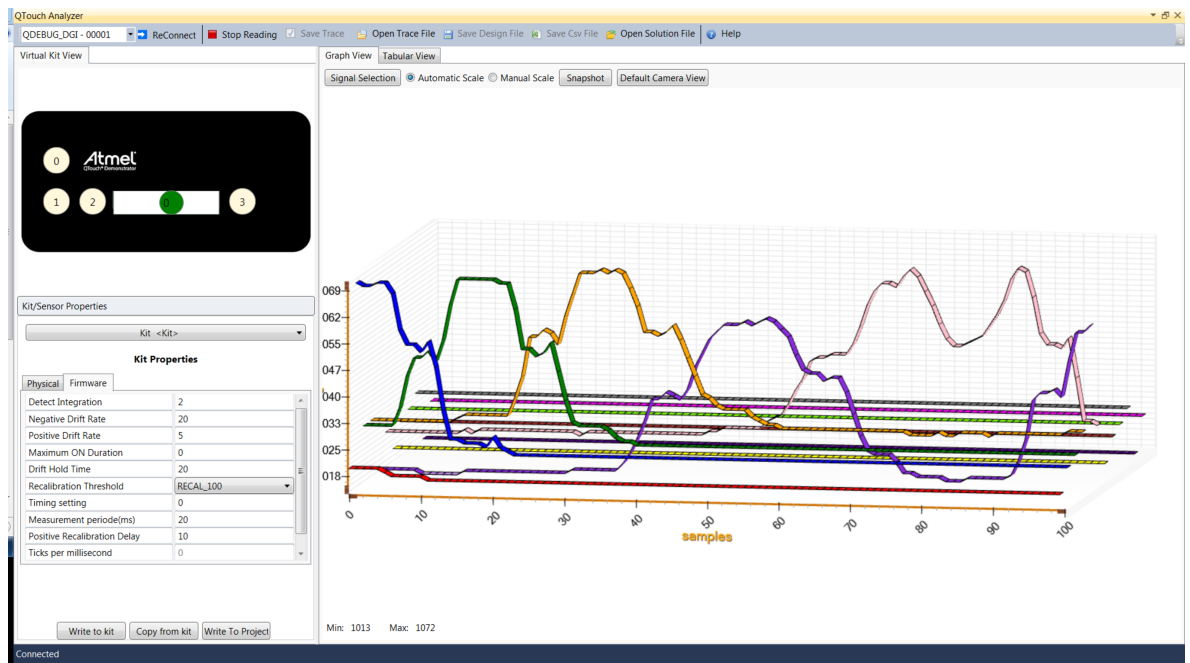

## 8. Switch Operation

There are two slide switches available on the board that can be used to enable or disable the countermeasures in the firmware. These switches are present on the top side of the board.

Figure 8-1 Switch Position in the Kit

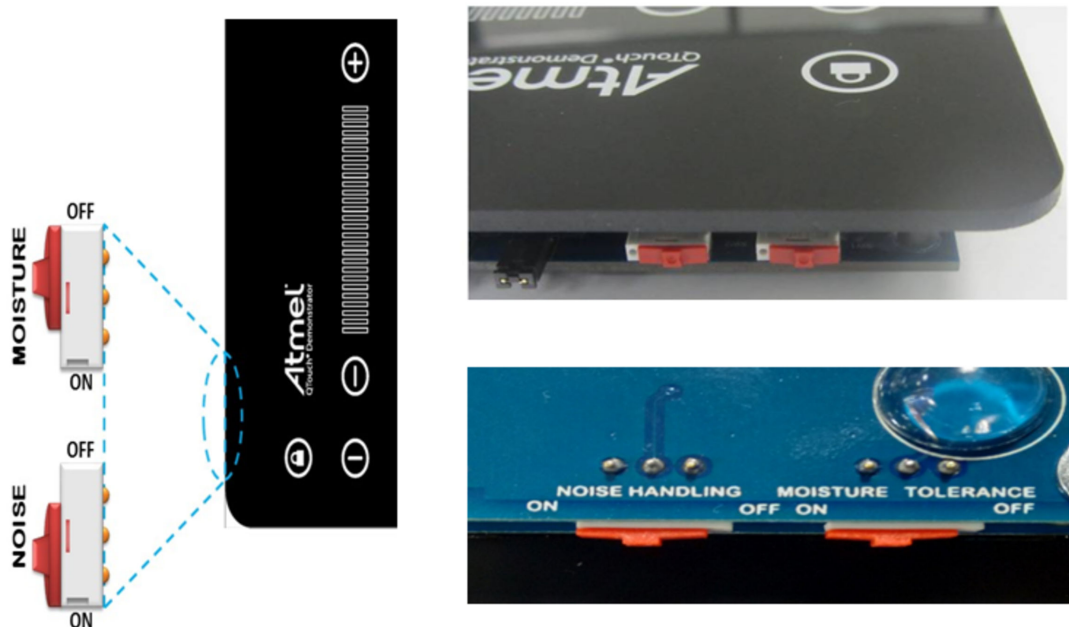

### 8.1. Noise Handling

The NOISE HANDLING switch is used to enable or disable the noise countermeasures in the firmware. The position of the switch should be kept at ON when the demo kit is subjected to Conducted Immunity noise testing or powered from noisy power supply.

There is a beep sound when the switch is moved from ON to OFF or vice versa.

### 8.2. Moisture Tolerance

The MOISTURE TOLERANCE switch is provided to enable or disable the moisture tolerance countermeasures in the firmware. The firmware is designed to detect the presence of moisture and lock the sensors to prevent false detects.

There is a beep sound when the switch is moved from ON to OFF or vice versa.

**Note:** Touch on multiple sensors simultaneously is not supported when this switch is in ON position.

## 9. Board Operation

### 9.1. Product Layout

Figure 9-1 Layout of Sensors on the Kit

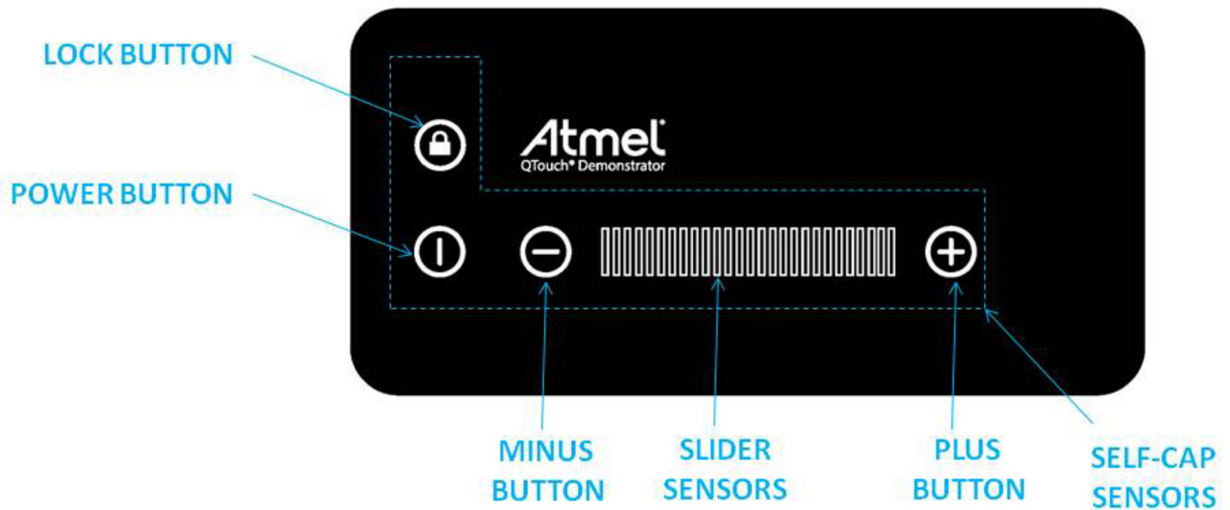

### 9.2. Lock Button

The lock button is used to enable or disable all other touch sensors in the kit. While lock is enabled, the other sensors will not respond to touch.

The LED for lock the button will remain glowing to indicate the locked state of the touch panel. Touching the Lock button in lock state will release the lock and the LED will turn OFF.

There is a long beep when the button detection put the panel in locked state and there will be a short beep when the panel is released from the lock state.

### 9.3. Button Description

#### 9.3.1. Minus Button

This minus button is used to decrement the slider position and the value will be displayed on the seven segment LED display. A single tap on the button decrements the displayed position value by one count. Continuous touch on the **minus** button will decrement the position value one by one until it reaches the minimum value as "0".

#### 9.3.2. Plus Button

This plus button is used to increment the slider position and the value will be displayed on the seven segment LED display. A single tap on the button increments the displayed position value by one count. Continuous touch on the **plus** button will increment the position value one by one until reach of the maximum value as "b".

### 9.3.3. Power Button

The power button is used to turn the panel ON or OFF

The LED for power button will remain glowing to indicate the ON state of the touch panel. The seven segment LED display shows zero when the power button is in ON state. Touching the power button again, the touch panel will be put to OFF state and the LED will stop glowing.

There is a long beep when the button in OFF state comes into detect and the touch panel is activated. A short beep is made when the button comes in to detect in ON state and the touch panel is deactivated.

### 9.3.4. Slider Sensors

The slider is made of six individual self-capacitance button sensors and is interpreted as a low resolution slider in the application. The number of positions reported is 11; from 0 to 9, and b. The reported position in the application will be displayed on the seven segment LED display.



## 10. Operating Modes of the Kit

### 10.1. Application Flow

Figure 10-1 Top Level Application Flowchart of SAM C20 QTouch Robustness Demo Firmware

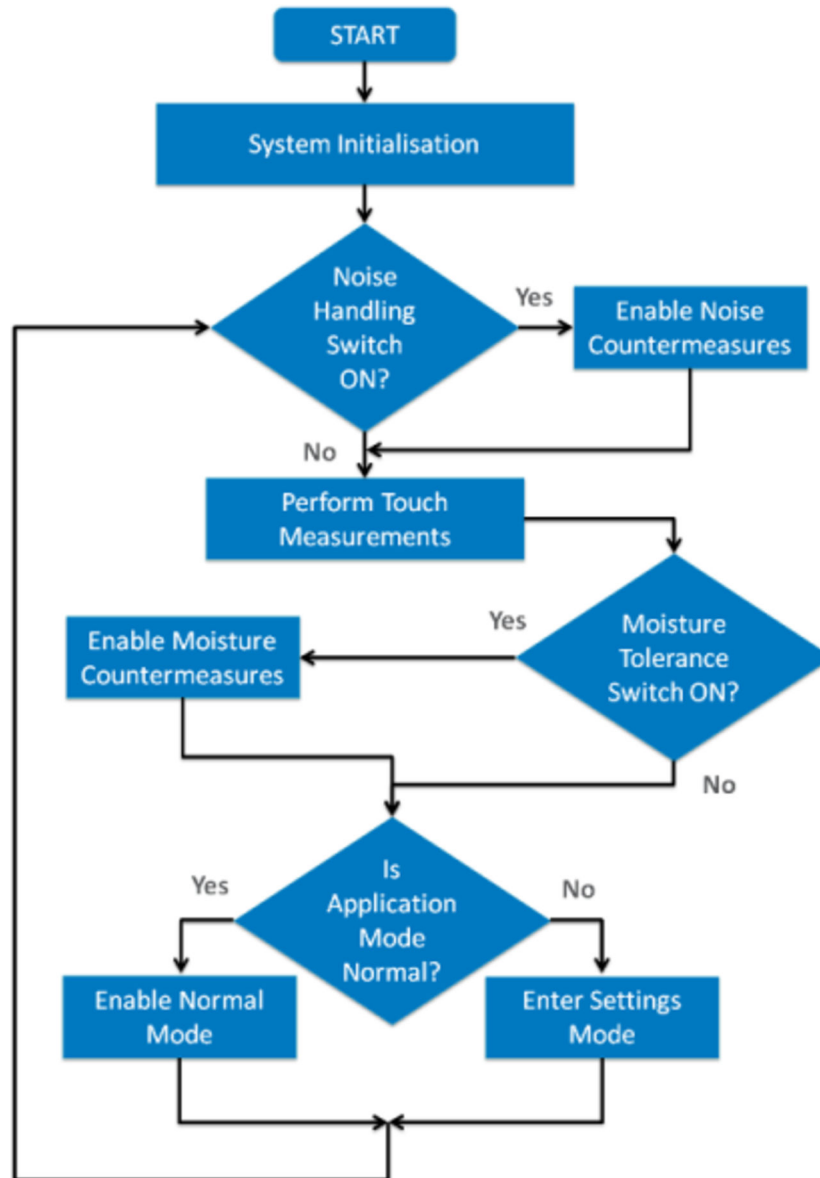

### 10.2. Normal Mode

In this mode all sensors are operational. For every valid touch there is a short beep. If you touch the slider the corresponding position will display on the seven segment LED display. The slider position can also be changed by touching the plus or minus button.

### 10.3. Mode Change

To change the application mode, press and hold both the plus and the minus buttons for one second. This will change the mode to Settings mode if the current mode is Normal and vice versa.

**Note:** If the kit is left in Settings mode for more than ten seconds, it will automatically switch to Normal mode.

### 10.4. Settings Mode

#### 10.4.1. Buzzer Volume Adjustment

Following are the steps to adjust the volume of the buzzer. Ensure that you are in Settings mode.

- Press and hold both the **plus** and the **minus** button for one second. A beep will indicate that you have entered into Settings mode.
- The LED segment display will indicate the corresponding digit of the current volume setting. Adjust the volume level by using the slider. The buzzer sound is audible as long as the slider is touched.
- Press and hold the **plus** and the **minus** button for one second. This will save the buzzer volume level.

**Note:** The buzzer volume is saved into the NVM. The volume setting is retained in the memory even after power cycle. The buzzer volume is to be manually set; there is no provision for automatic reset of buzzer volume.

Figure 10-2 Application Flow for the Settings Mode

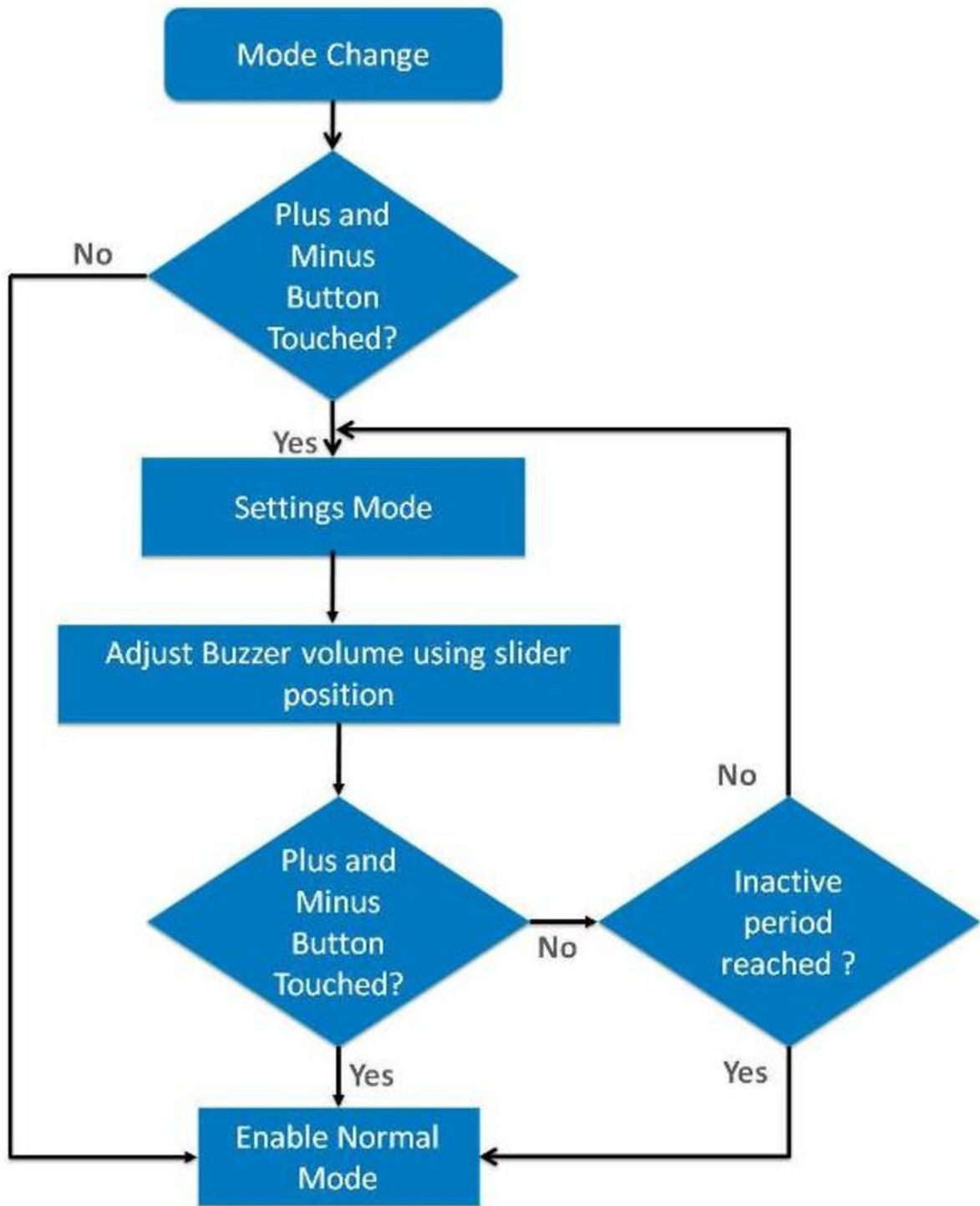

# 11. Schematic

Figure 11-1 MCU and Sensor Configuration Section

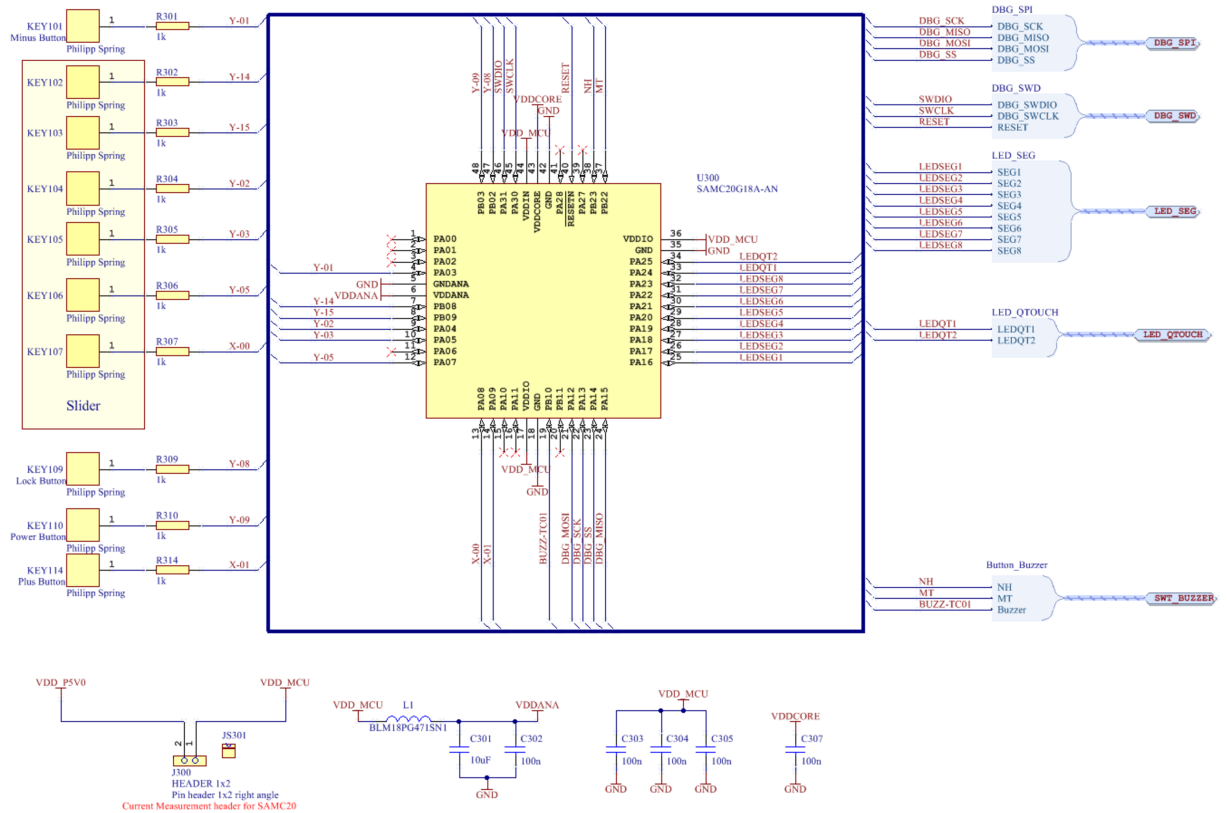

Figure 11-2 LED Segment, Buzzer, and Switch Section

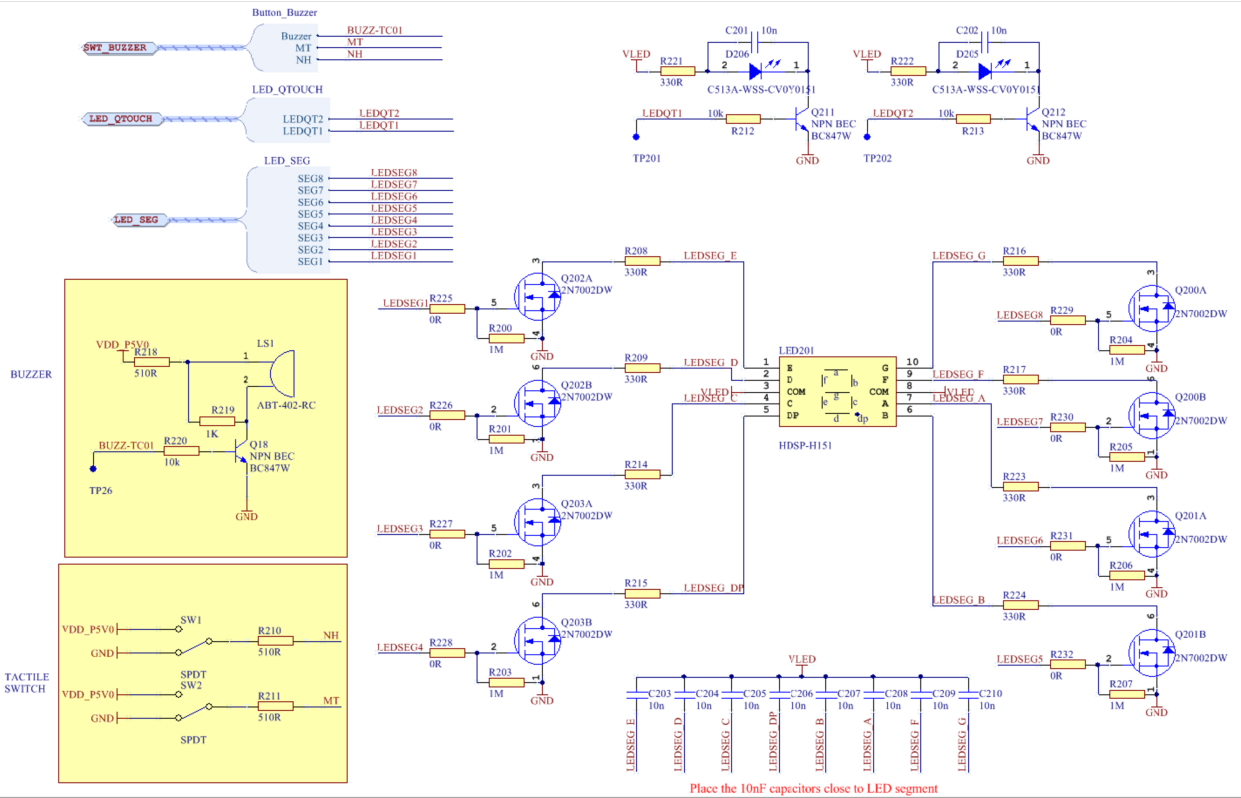
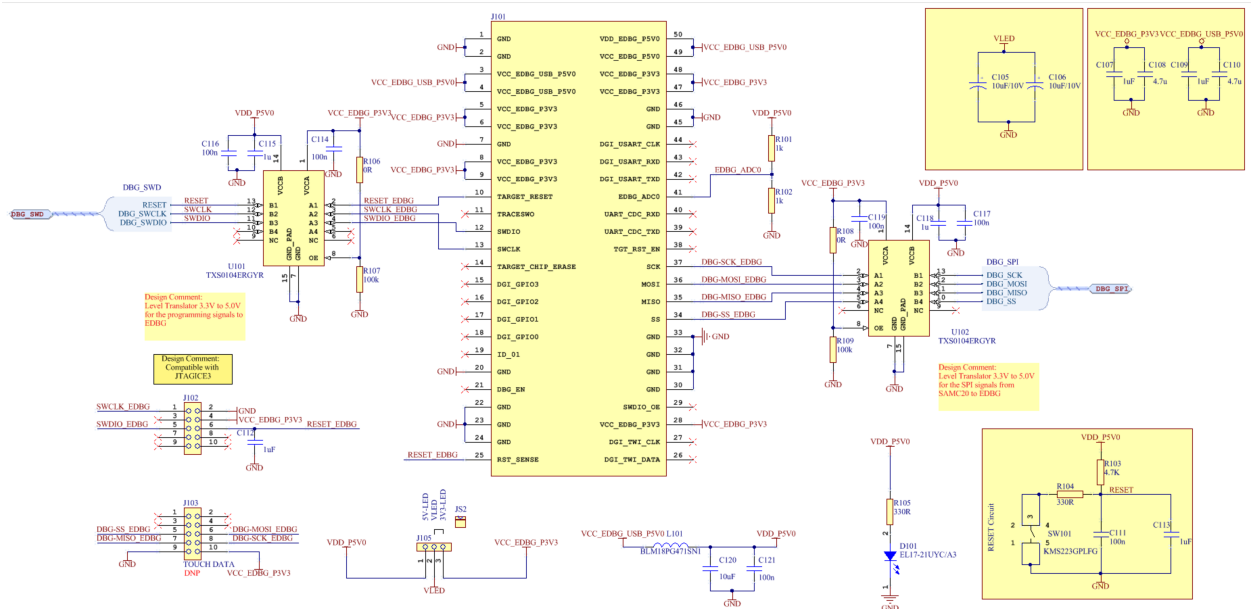

Figure 11-3 EDBG Headers and Connectors



## 12. PCB Design

Figure 12-1 Top Layer

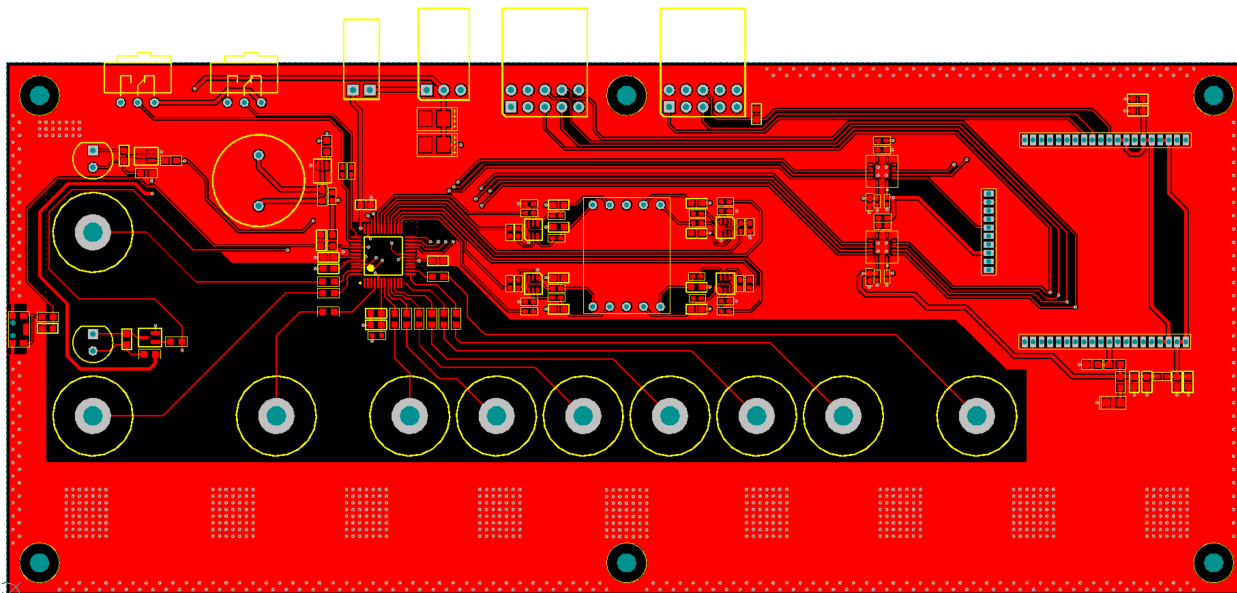
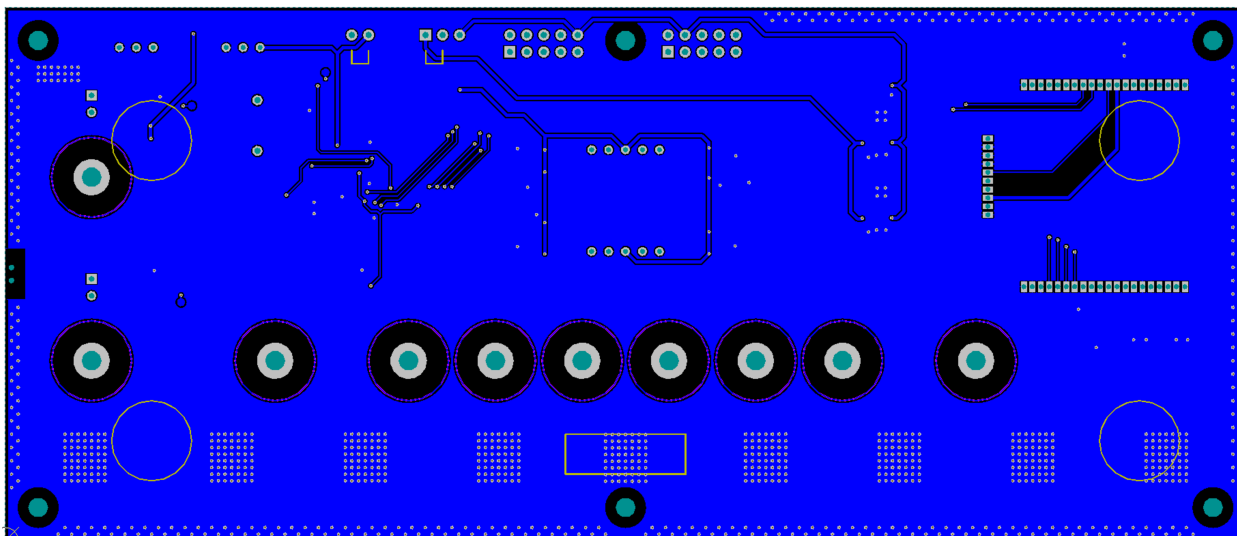

Figure 12-2 Bottom Layer



## 13. Bill of Materials

Table 13-1 Top Level Bill of Materials

COMPONENT	QUANTITY
Acrylic Front Panel	1
SAM C20 QTouch Robustness Demo Base Board - PCBA	1
Atmel EDBG-PCBA	1
(Rubber Feet) Bump-on	4
Plastic Spacers 11.8mm	6
Nylon Screw 4.3mm	6

Table 13-2 Bill of Material for the Base Board

Designator	Quantity	Value	Description
C107, C109, C112, C113	4	1 $\mu$ F	SMD Capacitor 0603
C108, C110	2	4.7 $\mu$ F	SMD Capacitor 0603
C111, C121, C302, C303, C304, C305, C307	7	100nF	SMD Capacitor 0603
C114, C116, C117, C119	4	100nF	SMD Capacitor 0402
C115, C118	2	1 $\mu$ F	SMD Capacitor 0402
C120, C301	2	10 $\mu$ F	SMD Capacitor 0603
C201, C202, C203, C204, C205, C206, C207, C208, C209, C210	10	10nF	SMD Capacitor 0603
D101	1	EL17-21UYC/A3	Yellow LED SMD 0805
D205, D206	2	C513A-WSS-CV0Y0151	5mm White LED_TH
E1, E2, E3, E4	4	SJ-5303	Adhesive feet, diam. 11.1mm
J101	1	EDBG module	Atmel Generic EDBG module
J102	1	RT Pin Header 2X5	Right Angle Header 2x5
J103	1	RT Pin Header 2X5	Right Angle Header 2x5
J105	1	RT Pin Header 1X3	Right Angle Header 1x3
J300	1	Pin header 1x2 right angle	Right Angle Header 1x2
JS2, JS301	2	SNT-100-BK-G	Jumper cap for 2.54mm pinheader
KEY101, KEY102, KEY103, KEY104, KEY105, KEY106, KEY107, KEY109, KEY110, KEY114	10	Philipp Spring	Spring for touch applications

Designator	Quantity	Value	Description
L1, L101	2	BLM18PG471SN1	SMD RF inductor 0603
LED201	1	HDSP-H151	LED 7-SEG, Red, Common Anode
LS1	1	ABT-402-RC	Buzzer
PCB1	1	SAMC20 QTR Demo Base Board PCB Documentation	SAMC20 QTR Demo Base Board PCB Documentation
Q18, Q211, Q212	3	BC847W	NPN SMD BJT transistor
Q200, Q201, Q202, Q203	4	2N7002DW	Dual N-Channel MOSFET
R101, R102, R219, R301, R302, R303, R304, R305, R306, R307, R309, R310, R314	13	1k $\Omega$	SMD Resistor 0603
R103	1	4.7k $\Omega$	SMD Resistor 0603
R104, R105, R221, R222	4	330 $\Omega$	SMD Resistor 0603
R106, R108, R225, R226, R227, R228, R229, R230, R231, R232	10	0 $\Omega$	SMD Resistor 0402
R107, R109	2	100k $\Omega$	SMD Resistor 0402
R200, R201, R202, R203, R204, R205, R206, R207	8	1M $\Omega$	SMD Resistor 0402
R208, R209, R214, R215, R216, R217, R223, R224	8	330 $\Omega$	SMD Resistor 0402
R210, R211, R218	3	510 $\Omega$	SMD Resistor 0402
R212, R213, R220	3	10k $\Omega$	SMD Resistor 0603
SW1, SW2	2	SPDT	Slide Switch
SW101	1	KMS223GPLFG	SMT Side Actuator
U101, U102	2	TXS0104ERGYR	Voltage Level Translator
U300	1	SAMC20G18A-AN	MCU



## 14. Reference

- [1]. QTAN0079: Buttons, Sliders and Wheels, Touch Sensor Design Guide - <http://www.atmel.com/Images/doc10752.pdf>
- [2]. SAM D Peripheral Touch Controller User Guide - [http://www.atmel.com/Images/Atmel-42195-QTouch-General-Library-Peripheral-Touch-Controller\\_User-Guide.pdf](http://www.atmel.com/Images/Atmel-42195-QTouch-General-Library-Peripheral-Touch-Controller_User-Guide.pdf)
- [3]. AT09363: PTC Robustness Design Guide, application note - [http://www.atmel.com/images/atmel-42360-ptc-robustness-design-guide\\_applicationnote\\_at09363.pdf](http://www.atmel.com/images/atmel-42360-ptc-robustness-design-guide_applicationnote_at09363.pdf)

## 15. Revision History

Doc Rev.	Date	Comments
42525A	09/2015	Initial document release.



Atmel® | Enabling Unlimited Possibilities®



Atmel Corporation 1600 Technology Drive, San Jose, CA 95110 USA T: (+1)(408) 441.0311 F: (+1)(408) 436.4200 | [www.atmel.com](http://www.atmel.com)

© 2015 Atmel Corporation. / Rev.: Atmel-42525A-SAM-C20-QTouch-Robustness-Demo\_User Guide-09/2015

Atmel®, Atmel logo and combinations thereof, Enabling Unlimited Possibilities®, QTouch® and others are registered trademarks or trademarks of Atmel Corporation in U.S. and other countries. ARM®, ARM Connected® logo, and others are the registered trademarks or trademarks of ARM Ltd. Other terms and product names may be trademarks of others.

**DISCLAIMER:** The information in this document is provided in connection with Atmel products. No license, express or implied, by estoppel or otherwise, to any intellectual property right is granted by this document or in connection with the sale of Atmel products. EXCEPT AS SET FORTH IN THE ATMEL TERMS AND CONDITIONS OF SALES LOCATED ON THE ATMEL WEBSITE, ATMEL ASSUMES NO LIABILITY WHATSOEVER AND DISCLAIMS ANY EXPRESS, IMPLIED OR STATUTORY WARRANTY RELATING TO ITS PRODUCTS INCLUDING, BUT NOT LIMITED TO, THE IMPLIED WARRANTY OF MERCHANTABILITY, FITNESS FOR A PARTICULAR PURPOSE, OR NON-INFRINGEMENT. IN NO EVENT SHALL ATMEL BE LIABLE FOR ANY DIRECT, INDIRECT, CONSEQUENTIAL, PUNITIVE, SPECIAL OR INCIDENTAL DAMAGES (INCLUDING, WITHOUT LIMITATION, DAMAGES FOR LOSS AND PROFITS, BUSINESS INTERRUPTION, OR LOSS OF INFORMATION) ARISING OUT OF THE USE OR INABILITY TO USE THIS DOCUMENT, EVEN IF ATMEL HAS BEEN ADVISED OF THE POSSIBILITY OF SUCH DAMAGES. Atmel makes no representations or warranties with respect to the accuracy or completeness of the contents of this document and reserves the right to make changes to specifications and products descriptions at any time without notice. Atmel does not make any commitment to update the information contained herein. Unless specifically provided otherwise, Atmel products are not suitable for, and shall not be used in, automotive applications. Atmel products are not intended, authorized, or warranted for use as components in applications intended to support or sustain life.

**SAFETY-CRITICAL, MILITARY, AND AUTOMOTIVE APPLICATIONS DISCLAIMER:** Atmel products are not designed for and will not be used in connection with any applications where the failure of such products would reasonably be expected to result in significant personal injury or death ("Safety-Critical Applications") without an Atmel officer's specific written consent. Safety-Critical Applications include, without limitation, life support devices and systems, equipment or systems for the operation of nuclear facilities and weapons systems. Atmel products are not designed nor intended for use in military or aerospace applications or environments unless specifically designated by Atmel as military-grade. Atmel products are not designed nor intended for use in automotive applications unless specifically designated by Atmel as automotive-grade.

# Mouser Electronics

Authorized Distributor

Click to View Pricing, Inventory, Delivery & Lifecycle Information:

[Microchip:](#)

[ATSAMC20-QTRDEMO](#)



Компания «ЭлектроПласт» предлагает заключение долгосрочных отношений при поставках импортных электронных компонентов на взаимовыгодных условиях!

Наши преимущества:

- Оперативные поставки широкого спектра электронных компонентов отечественного и импортного производства напрямую от производителей и с крупнейших мировых складов;
- Поставка более 17-ти миллионов наименований электронных компонентов;
- Поставка сложных, дефицитных, либо снятых с производства позиций;
- Оперативные сроки поставки под заказ (от 5 рабочих дней);
- Экспресс доставка в любую точку России;
- Техническая поддержка проекта, помощь в подборе аналогов, поставка прототипов;
- Система менеджмента качества сертифицирована по Международному стандарту ISO 9001;
- Лицензия ФСБ на осуществление работ с использованием сведений, составляющих государственную тайну;
- Поставка специализированных компонентов (Xilinx, Altera, Analog Devices, Intersil, Interpoint, Microsemi, Aeroflex, Peregrine, Syfer, Eurofarad, Texas Instrument, Miteq, Cobham, E2V, MA-COM, Hittite, Mini-Circuits, General Dynamics и др.);

Помимо этого, одним из направлений компании «ЭлектроПласт» является направление «Источники питания». Мы предлагаем Вам помощь Конструкторского отдела:

- Подбор оптимального решения, техническое обоснование при выборе компонента;
- Подбор аналогов;
- Консультации по применению компонента;
- Поставка образцов и прототипов;
- Техническая поддержка проекта;
- Защита от снятия компонента с производства.



#### Как с нами связаться

**Телефон:** 8 (812) 309 58 32 (многоканальный)

**Факс:** 8 (812) 320-02-42

**Электронная почта:** [org@eplast1.ru](mailto:org@eplast1.ru)

**Адрес:** 198099, г. Санкт-Петербург, ул. Калинина, дом 2, корпус 4, литера А.