

1

2

3

4

5

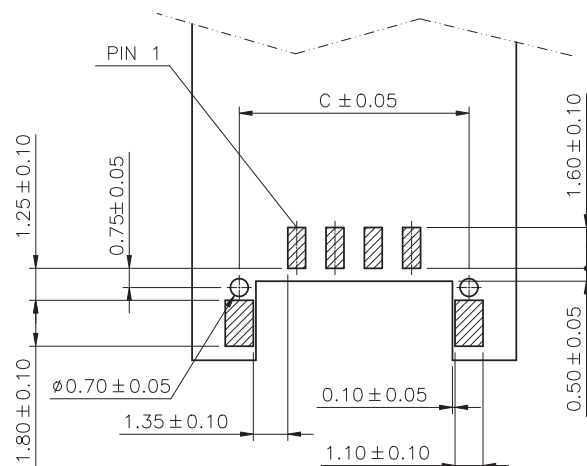
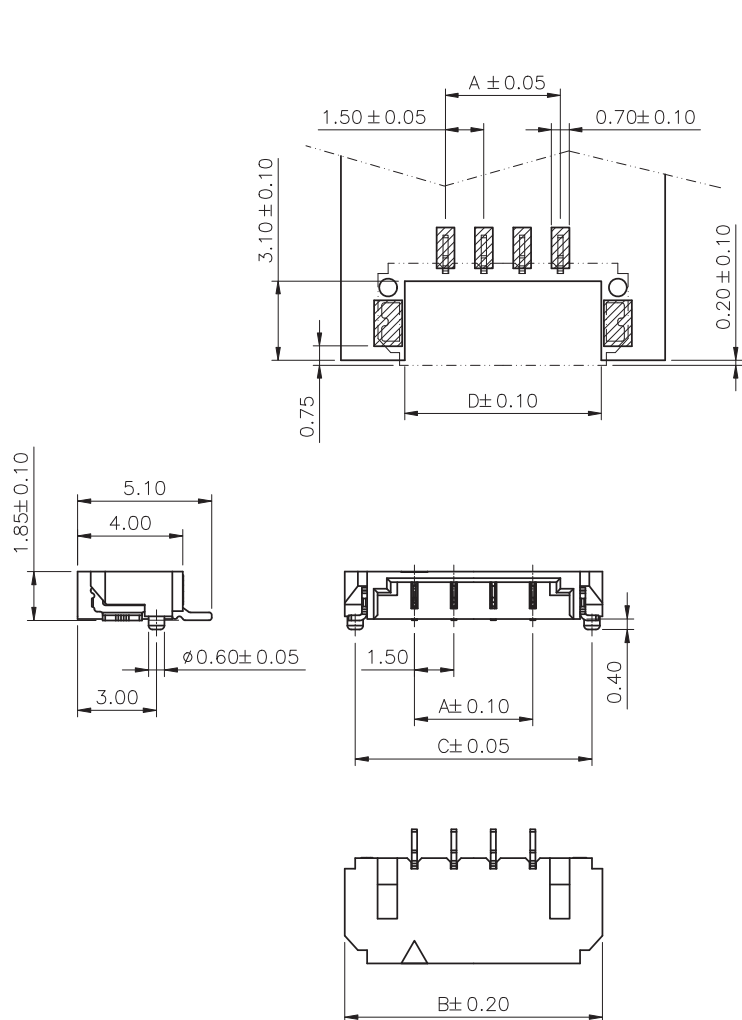

PCB LAYOUT - COMPONENT VIEW

TECHNICAL CHARACTERISTICS

MATERIAL

INSULATOR: PA6T

FLAMMABILITY RATING: UL94V0

COLOR: WHITE

CONTACT MATERIAL: PHOSPHOR BRONZE

CONTACT PLATING: 3.05 μ m MAT TIN OVER 1.27 μ m Ni

SOLDER TAB MATERIAL: BRASS

SOLDER TAB PLATING: 3.05 μ m MAT TIN OVER 1.27 μ m Ni

ENVIRONMENTAL

OPERATING TEMPERATURE: -25°C UP TO +85°C

COMPLIANCE: HALOGEN AND ROHS

ELECTRICAL

CURRENT RATING: 1A MAX

WORKING VOLTAGE: 150 VAC

WITHSTANDING VOLTAGE: 1300 VAC/MIN

INSULATION RESISTANCE: > 1000 M Ω CONTACT RESISTANCE: 20 m Ω MAX

PITCH: 1,50 mm

SOLDERING

JEDEC LEAD FREE REFLOW SOLDERING PROCESS

PACKAGING

TAPE & REEL

DIMENSION

A= 1.5 x (NB. PIN -1)

B= A + 5.3

C= A + 4.5

D= A + 3.2

RoHS Compliant

PROJECTION:



GENERAL TOLERANCE

.X = \pm 0.2.XX = \pm 0.15

APPROVAL: GMo

UNIT: MM

SCALE:

SHEET: 1/4

DRAW: AK

DESCRIPTION: BtB 1.50MM PITCH PLUG HORIZONTAL

WERI PART NO: 695 4xx 150 122

SIZE

A4

F			
E			
D			
C			
B			
A	16-JUN-15	PDF	AK
REV	DATE	FILE	BY

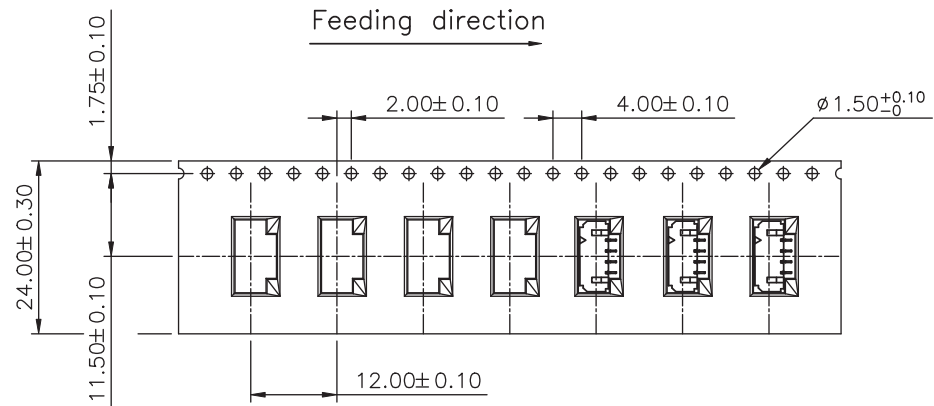
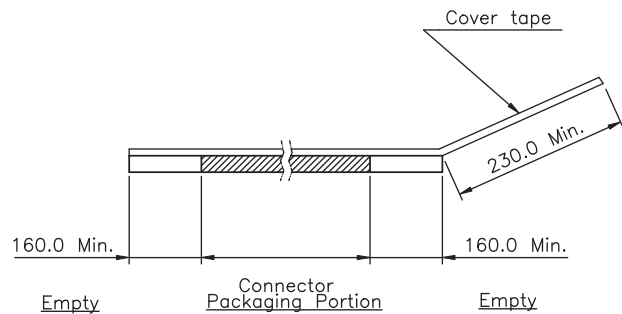
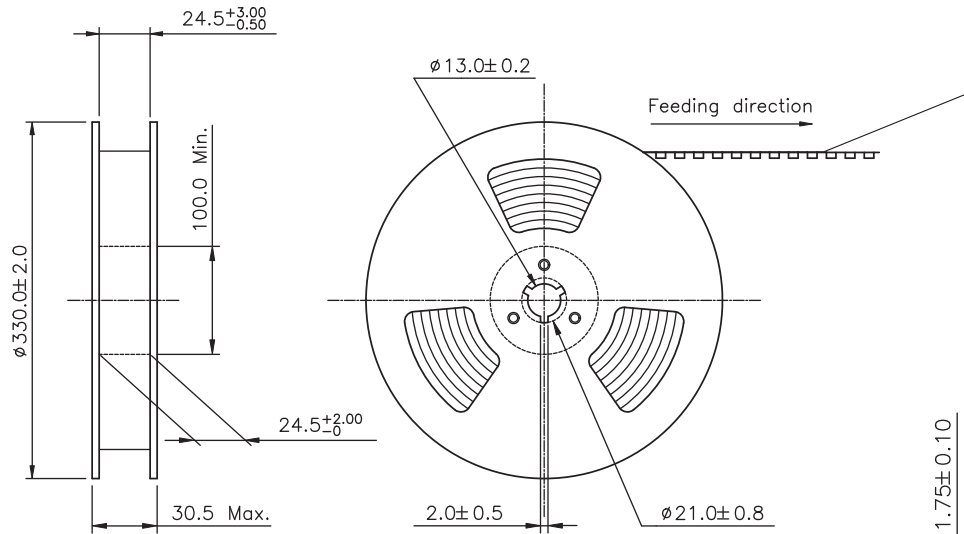



WIDTH : 24 mm Carrier

1800 pcs/reel
9 reels/carton
16200 pcs/carton

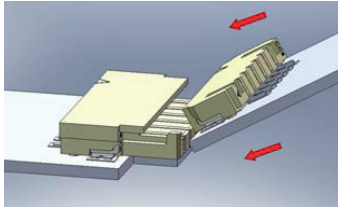
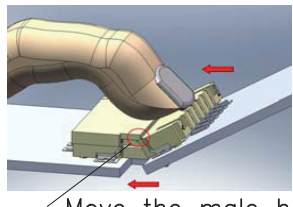
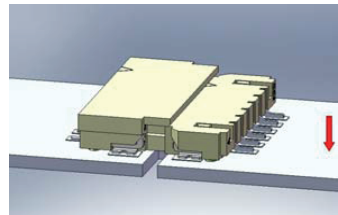
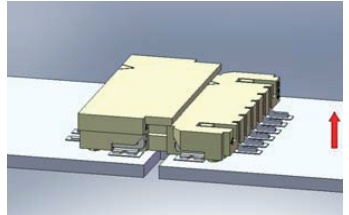
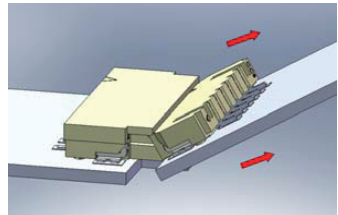
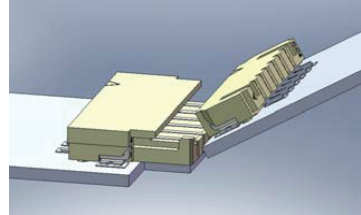
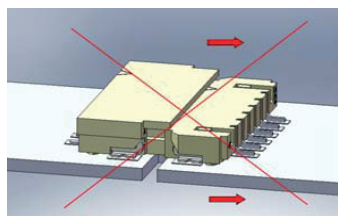
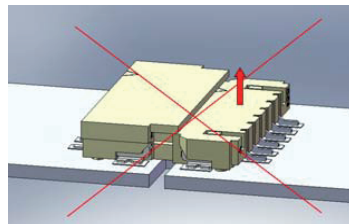
RoHS Compliant				PROJECTION: 	GENERAL TOLERANCE .X = +/- 0.2 .XX = +/- 0.15		DESCRIPTION: BtB 1.50MM PITCH PLUG HORIZONTAL	SIZE A4
F								
E								
D								
C			APPROVAL: GMo					
B								
A		PDF						
REV	DATE	FILE	BY					
				UNIT: MM	DESCRIPTION: BtB 1.50MM PITCH PLUG HORIZONTAL		SIZE A4	
				SCALE:	WERI PART NO: 695 4xx 150 122			
				SHEET: 2/4				
				DRAW: AK				

	1	2	3	4	5	
Mating	<p>Step 1: The male header should be tilted during insertion.</p>  <p>Female Male</p>	<p>Step 2: Push the male header to the end. Make sure the male header is under the rib of female header by finger.</p>  <p>Female Male</p>	<p>Step 3: Press down the male header down vertically to finish the connection.</p>  <p>Female Male</p>	A		
	<p>Step 1: Lift the male header up at 30°~60°.</p>  <p>Female Male</p>	<p>Step 2: Remove male header at an angle to finish the disconnection.</p>  <p>Female Male</p>	<p>Step 3: Finish</p>  <p>Female Male</p>		B	
	<p>Please do not separate the connectors horizontally to prevent damaging them.</p>  <p>Female Male</p>	<p>Please do not separate the connectors vertically to prevent damaging them.</p>  <p>Female Male</p>				C

RoHS Compliant				PROJECTION:	GENERAL TOLERANCE		DESCRIPTION: BtB 1.50MM PITCH PLUG HORIZONTAL	SIZE
F					.X = +/- 0.2			
E				APPROVAL: GMo	.XX = +/- 0.15	UNIT: MM SCALE: SHEET: 3/4 DRAW: AK	WERI PART NO: 695 4xx 150 122	
D								
C								
B								
A		PDF						
REV	DATE	FILE	BY					

1

2

3

4

5

Cautions and Warnings:

This electronic component is designed and developed with the intention for use in general electronics equipments.



Before incorporating the components into any equipments in the field such as aerospace, aviation, nuclear control, submarine, transportation, (automotive control, train control, ship control), transportation signal, disaster prevention, medical, public information network etc. where higher safety and reliability are especially required or if there is possibility of direct damage or injury to human body, Würth Elektronik must be asked for a written approval.

In addition, even electronic component in general electronic equipments, when used in electrical circuits that require high safety, reliability functions or performance, the sufficient reliability evaluation-check for the safety must be performed before by the user before usage.

A

B

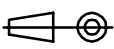
C

RoHS Compliant				PROJECTION: 	GENERAL TOLERANCE .X = +/- 0.2 .XX = +/- 0.15	 WÜRTH ELEKTRONIK	DESCRIPTION: DISCLAIMER	SIZE A4
G								
F								
E								
D								
C				APPROVAL: JC	UNIT: MM	WERI PART NO: DISCLAIMER	SIZE A4	
B				SCALE:				
A	10-SEP-14	PDF	QL	SHEET: 4/4				
REV	DATE	FILE	BY	DRAW: QL				

D



Компания «ЭлектроПласт» предлагает заключение долгосрочных отношений при поставках импортных электронных компонентов на взаимовыгодных условиях!

Наши преимущества:

- Оперативные поставки широкого спектра электронных компонентов отечественного и импортного производства напрямую от производителей и с крупнейших мировых складов;
- Поставка более 17-ти миллионов наименований электронных компонентов;
- Поставка сложных, дефицитных, либо снятых с производства позиций;
- Оперативные сроки поставки под заказ (от 5 рабочих дней);
- Экспресс доставка в любую точку России;
- Техническая поддержка проекта, помощь в подборе аналогов, поставка прототипов;
- Система менеджмента качества сертифицирована по Международному стандарту ISO 9001;
- Лицензия ФСБ на осуществление работ с использованием сведений, составляющих государственную тайну;
- Поставка специализированных компонентов (Xilinx, Altera, Analog Devices, Intersil, Interpoint, Microsemi, Aeroflex, Peregrine, Syfer, Eurofarad, Texas Instrument, Miteq, Cobham, E2V, MA-COM, Hittite, Mini-Circuits, General Dynamics и др.);

Помимо этого, одним из направлений компании «ЭлектроПласт» является направление «Источники питания». Мы предлагаем Вам помощь Конструкторского отдела:

- Подбор оптимального решения, техническое обоснование при выборе компонента;
- Подбор аналогов;
- Консультации по применению компонента;
- Поставка образцов и прототипов;
- Техническая поддержка проекта;
- Защита от снятия компонента с производства.



Как с нами связаться

Телефон: 8 (812) 309 58 32 (многоканальный)

Факс: 8 (812) 320-02-42

Электронная почта: org@eplast1.ru

Адрес: 198099, г. Санкт-Петербург, ул. Калинина, дом 2, корпус 4, литера А.