

Ideal for Detecting Ice, Pure Water, or Humidity

- Applicable for detecting ice, pure water steam, humidity, or other substances that conduct electricity poorly.
- Two types of model available: Ultra high-sensitivity and variable ultra high-sensitivity.



 Refer to *Safety Precautions for Floatless Level Controllers*.

Ordering Information

Type	Ultra high-sensitivity	Variable ultra high-sensitivity
	Model	Model
Ultra high-sensitivity	61F-UHS	61F-HSL

Note: When ordering, specify the desired operating voltage at the end of the model number.

Example: 61F-UHS [220VAC]

└── Desired supply voltage

Ultra High-sensitivity Models

Use these models for sensing objects such as ice, high-purity distilled water, moisture, or other objects with low electrical conductivity.

Specifications

Item	High-sensitivity 61F-UHS	Variable high-sensitivity 61F-HSL
Supply voltage	100, 200, or 220 VAC; 50/60 Hz	24, 100, 110, 200, or 220 VAC; 50/60 Hz
Operating voltage range	85% to 110% of rated voltage	
Interelectrode voltage	24 VAC	13 VDC max.
Interelectrode current	Approx. 1 mA AC max.	Approx. 1 mA DC max.
Power consumption	3.2 VA max.	
Interelectrode operate resistance	0 to approx. 1 MΩ (see note 1)	0 to approx. 5 MΩ (variable)
Interelectrode release resistance	Approx. 5 M to ∞ Ω	Operate resistance + 2.5 MΩ max.
Cable length	5 m (see note 2)	(see note 3)
Control output	0.3 A, 220 VAC (Inductive load: $\cos\phi = 0.4$) 1 A, 220 VAC (Resistive load)	2 A, 220 VAC (Inductive load: $\cos\phi = 0.4$) 5 A, 220 VAC (Resistive load)
Ambient temperature	Operating: -10 to 55°C	
Ambient humidity	Operating: 45% to 85% RH	
Insulation resistance	100 MΩ max. (at 500 VDC)	
Dielectric strength	2,000 VAC, 50/60 Hz for 1 min	
Life expectancy	Electrical: 50,000 operations min. Mechanical: 5,000,000 operations min.	Electrical: 500,000 operations min. Mechanical: 5,000,000 operations min.
Weight	Approx. 380 g	Approx. 240 g

Note: 1. Use 61F-UHS for detecting water leakage with high specific resistance. Connect a sensor cable between terminals 1 and 7.

2. Two Electrodes can be connected to the 61F-HSL. Use them for an alarm, not for creating a self-holding circuit.

3. The length when using completely-insulated, 600-V, 3-conductor (0.75 mm²) cable cables. Usable cable lengths will become shorter as the cable diameter or number of conductors becomes larger. For more details, refer to *Safety Precautions for Floatless Level Controllers*.

4. It is recommended that the cable length be kept as short as possible since the Electrode circuit current is at DC micro-current level. Moreover, the Electrodes will corrode rapidly if the current is allowed to constantly flow between the Electrodes. Be careful with the electrode polarity and grounding when wiring.

Internal Circuit Diagrams

61F-UHS

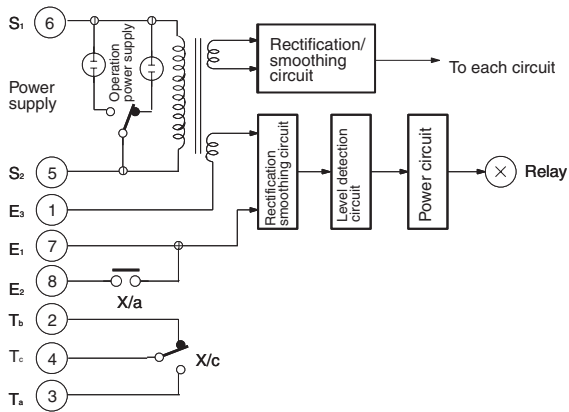

61F-HSL

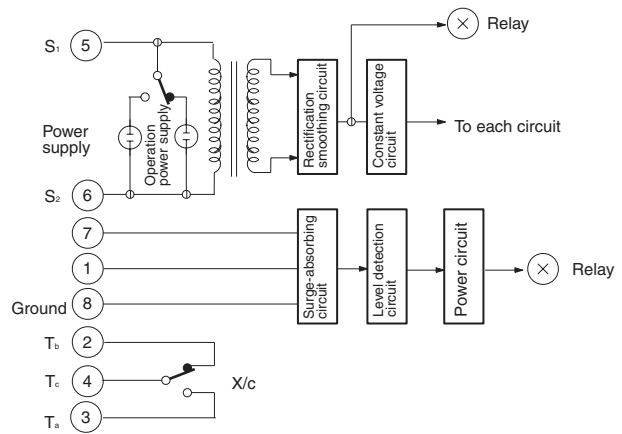

External Circuit Diagrams (Example)

61F-UHS

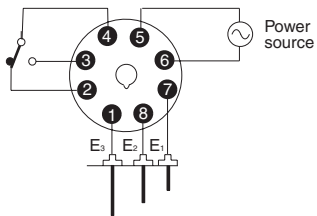

Socket: 8PFA1 (track mounted)/
PL08 (back connecting)

61F-HSL

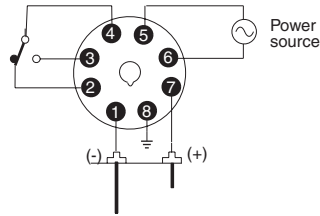

Socket: 8PFA (track mounted)/
PL08 (back connecting)

■ Connections

Automatic Water Supply and Drainage Control

Ultra High-sensitivity Type

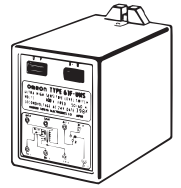

Dimensions:
Page 4

Automatic Water Supply Control	Automatic Drainage Control
<p>Connections</p> <p>Note: Be sure to ground the common Electrode E₃ (the longest Electrode).</p> <p>Connection Sockets 8PFA1 (Front-connecting) PL08 (Read-connecting)</p> <p>Connect terminal 2 to the contactor coil terminal.</p>	<p>Connections</p> <p>Note: Be sure to ground the common Electrode E₃ (the longest Electrode).</p> <p>Connection Sockets 8PFA1 (Front-connecting) PL08 (Read-connecting)</p> <p>Connect terminal 3 to the contactor coil terminal.</p>
<p>Principles of Operation</p> <ul style="list-style-type: none"> When the water level reaches E₁, the pump stops and, when the water level reaches E₂ or below, the pump starts. 	<p>Principles of Operation</p> <ul style="list-style-type: none"> When the water level reaches E₁, the pump starts and, when the water level reaches E₂ or below, the pump stops.

Dimensions

Note: All units are in millimeters unless otherwise indicated.

61F-UHS

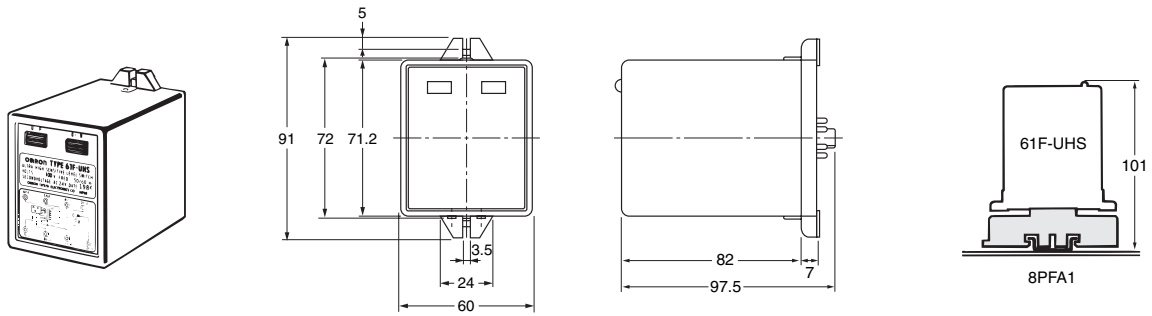

61F-HSL

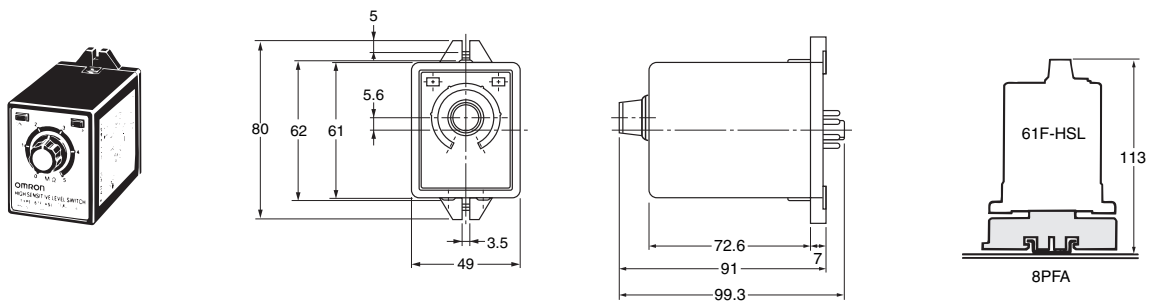

Electrode Holders

PS-3S/-4S/-5S
PS-3SR/-4SR/-5SR
(see note)

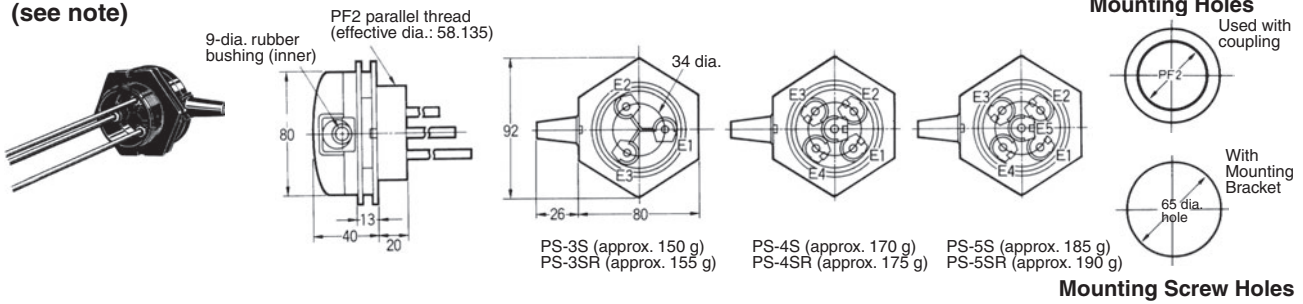

Note: The PS-3SR, PS-4SR, and PS-5SR have built-in resistor of 6.8 kΩ and used for the two-wire 61F models.

PS-31

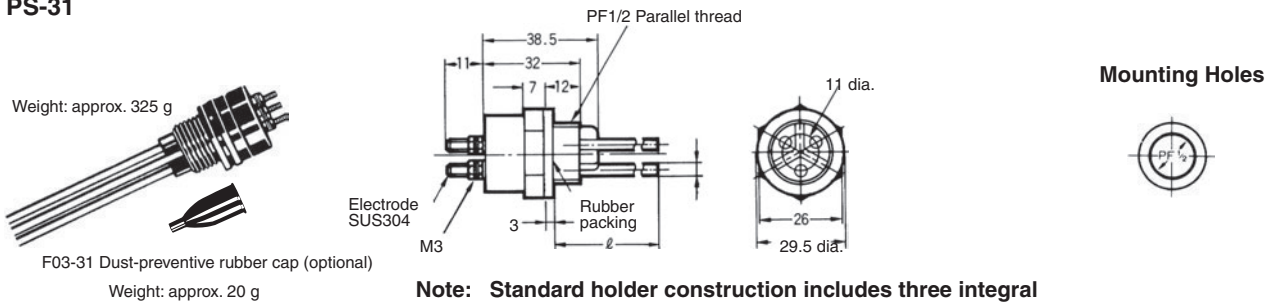

Note: Standard holder construction includes three integral 300-mm-long Electrodes. However, a model having 1,000-mm-long Electrodes is available on request.

BF-1

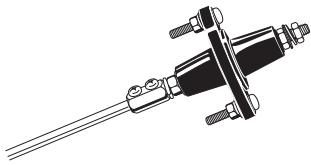

Weight: approx. 75 g

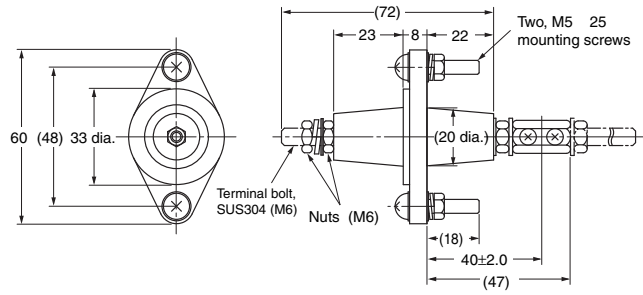

Mounting Holes

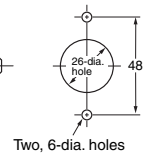

BF-3/-3R BF-5/-5R

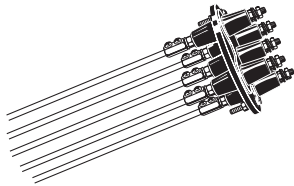

BF-3(R)

Weight
BF-3: approx. 210 g
BF-3R: approx. 215 g

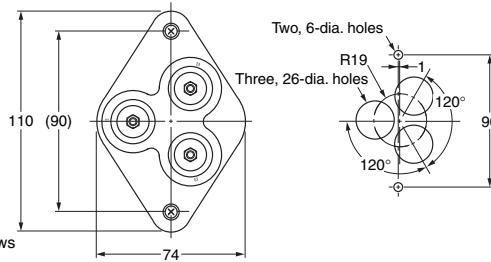

Mounting Holes

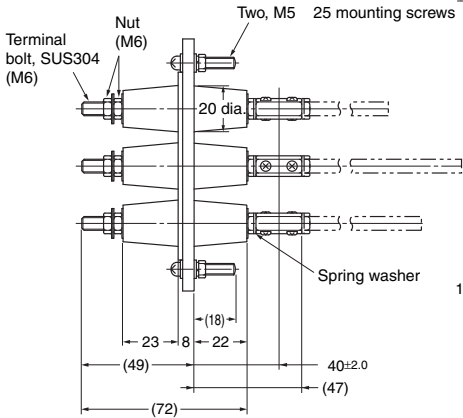
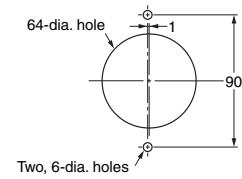

BF-5(R)

Weight
BF-5: approx. 360 g
BF-5R: approx. 365 g

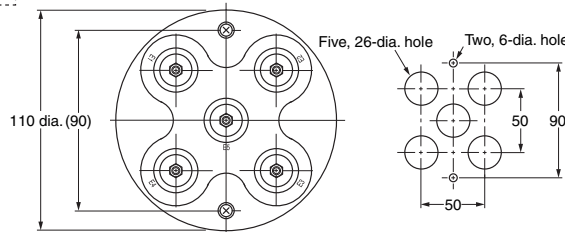

Mounting Holes

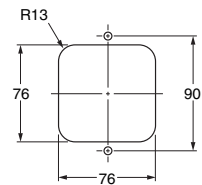

BS-1(S)

Weight: approx. 70 g

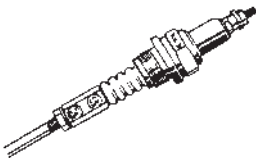

BS-1

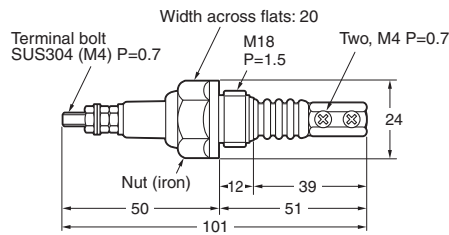

Mounting Holes

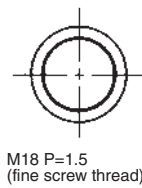

BS-1S BS-1S-1 BS-1S2

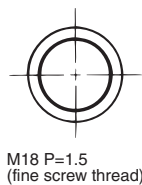
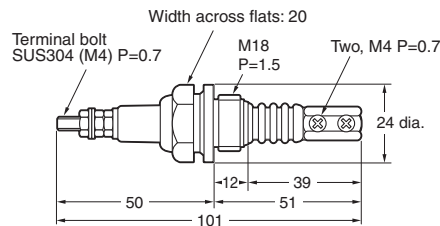

BS-1T

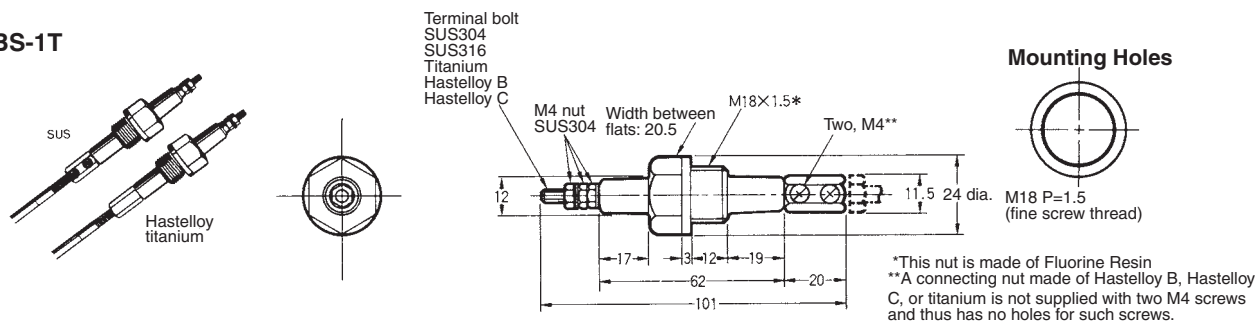

Material	SUS304	SUS316	Titanium	HAS B	HAS C
Weight	Approx. 55 g	Approx. 55 g	Approx. 45 g	Approx. 65 g	Approx. 60 g

PH-1

(Approx. 140 g with a 1-m cord)

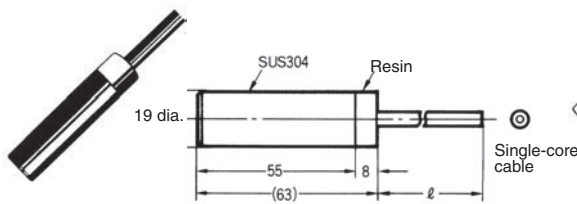

Cable OD: Vinyl 5.0 dia., Hypalon 6.5 dia.

PH-2

(Approx. 235 g with a 1-m cord)

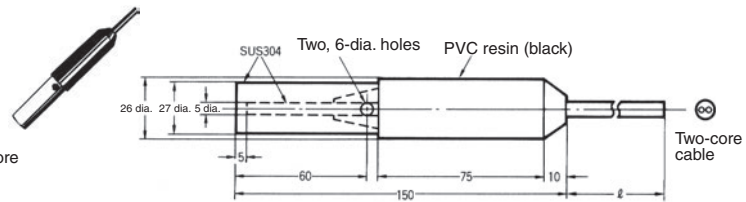

Cable OD: Vinyl, Hypalon 6.8 dia.

Note: Cable is supplied in lengths of 1, 5, 10, 15, 20, 30, 40, 50, 60, 70, 80, 90, or 100 meters.

■ Electrode Separators

F03-14 1P for one pole	F03-14 3P for three poles	F03-14 5P for five poles
<p>Weight: Approx. 15 g</p>	<p>Weight: Approx. 30 g</p>	<p>Weight: Approx. 30 g</p>

■ Safety Precautions

Refer to *Safety Precautions for All Level Controllers*.

Precautions for Correct Use

Short Wiring in Electrode Circuit

- Keep the wires connecting the Controller to Electrode Holders as short as possible. If long leads are used, the floating capacity of the leads, and abnormal surges or noise in the Electrode circuit can cause malfunctions.
- The thicker the cables, the shorter the permitted wiring length. The length of the cable connecting the Controller and Electrode is specified in the Controller datasheet as a guideline assuming that a 600-V VCT 0.75-mm², 3-core cable is used. Test results indicate that the actual wiring length using VCT 3.5-mm², 3-core cable laid over the ground is 50% of the specified length for general-purpose applications and 80% of the specified length for long-distance applications. When selecting cable specifications, remember that the wiring length is further decreased for underground cables and larger diameter cables because of the increased floating capacity with the ground.

ALL DIMENSIONS SHOWN ARE IN MILLIMETERS.
To convert millimeters into inches, multiply by 0.03937. To convert grams into ounces, multiply by 0.03527.

In the interest of product improvement, specifications are subject to change without notice.

Terms and Conditions Agreement

Read and understand this catalog.

Please read and understand this catalog before purchasing the products. Please consult your OMRON representative if you have any questions or comments.

Warranties.

(a) Exclusive Warranty. Omron's exclusive warranty is that the Products will be free from defects in materials and workmanship for a period of twelve months from the date of sale by Omron (or such other period expressed in writing by Omron). Omron disclaims all other warranties, express or implied.

(b) Limitations. OMRON MAKES NO WARRANTY OR REPRESENTATION, EXPRESS OR IMPLIED, ABOUT NON-INFRINGEMENT, MERCHANTABILITY OR FITNESS FOR A PARTICULAR PURPOSE OF THE PRODUCTS. BUYER ACKNOWLEDGES THAT IT ALONE HAS DETERMINED THAT THE PRODUCTS WILL SUITABLY MEET THE REQUIREMENTS OF THEIR INTENDED USE.

Omron further disclaims all warranties and responsibility of any type for claims or expenses based on infringement by the Products or otherwise of any intellectual property right. (c) Buyer Remedy. Omron's sole obligation hereunder shall be, at Omron's election, to (i) replace (in the form originally shipped with Buyer responsible for labor charges for removal or replacement thereof) the non-complying Product, (ii) repair the non-complying Product, or (iii) repay or credit Buyer an amount equal to the purchase price of the non-complying Product; provided that in no event shall Omron be responsible for warranty, repair, indemnity or any other claims or expenses regarding the Products unless Omron's analysis confirms that the Products were properly handled, stored, installed and maintained and not subject to contamination, abuse, misuse or inappropriate modification. Return of any Products by Buyer must be approved in writing by Omron before shipment. Omron Companies shall not be liable for the suitability or unsuitability or the results from the use of Products in combination with any electrical or electronic components, circuits, system assemblies or any other materials or substances or environments. Any advice, recommendations or information given orally or in writing, are not to be construed as an amendment or addition to the above warranty.

See <http://www.omron.com/global/> or contact your Omron representative for published information.

Limitation on Liability; Etc.

OMRON COMPANIES SHALL NOT BE LIABLE FOR SPECIAL, INDIRECT, INCIDENTAL, OR CONSEQUENTIAL DAMAGES, LOSS OF PROFITS OR PRODUCTION OR COMMERCIAL LOSS IN ANY WAY CONNECTED WITH THE PRODUCTS, WHETHER SUCH CLAIM IS BASED IN CONTRACT, WARRANTY, NEGLIGENCE OR STRICT LIABILITY.

Further, in no event shall liability of Omron Companies exceed the individual price of the Product on which liability is asserted.

Suitability of Use.

Omron Companies shall not be responsible for conformity with any standards, codes or regulations which apply to the combination of the Product in the Buyer's application or use of the Product. At Buyer's request, Omron will provide applicable third party certification documents identifying ratings and limitations of use which apply to the Product. This information by itself is not sufficient for a complete determination of the suitability of the Product in combination with the end product, machine, system, or other application or use. Buyer shall be solely responsible for determining appropriateness of the particular Product with respect to Buyer's application, product or system. Buyer shall take application responsibility in all cases.

NEVER USE THE PRODUCT FOR AN APPLICATION INVOLVING SERIOUS RISK TO LIFE OR PROPERTY OR IN LARGE QUANTITIES WITHOUT ENSURING THAT THE SYSTEM AS A WHOLE HAS BEEN DESIGNED TO ADDRESS THE RISKS, AND THAT THE OMRON PRODUCT(S) IS PROPERLY RATED AND INSTALLED FOR THE INTENDED USE WITHIN THE OVERALL EQUIPMENT OR SYSTEM.

Programmable Products.

Omron Companies shall not be responsible for the user's programming of a programmable Product, or any consequence thereof.

Performance Data.

Data presented in Omron Company websites, catalogs and other materials is provided as a guide for the user in determining suitability and does not constitute a warranty. It may represent the result of Omron's test conditions, and the user must correlate it to actual application requirements. Actual performance is subject to the Omron's Warranty and Limitations of Liability.

Change in Specifications.

Product specifications and accessories may be changed at any time based on improvements and other reasons. It is our practice to change part numbers when published ratings or features are changed, or when significant construction changes are made. However, some specifications of the Product may be changed without any notice. When in doubt, special part numbers may be assigned to fix or establish key specifications for your application. Please consult with your Omron's representative at any time to confirm actual specifications of purchased Product.

Errors and Omissions.

Information presented by Omron Companies has been checked and is believed to be accurate; however, no responsibility is assumed for clerical, typographical or proofreading errors or omissions.

2014.1

In the interest of product improvement, specifications are subject to change without notice.

OMRON Corporation
Industrial Automation Company

<http://www.ia.omron.com/>

(c)Copyright OMRON Corporation 2014 All Right Reserved.



Компания «ЭлектроПласт» предлагает заключение долгосрочных отношений при поставках импортных электронных компонентов на взаимовыгодных условиях!

Наши преимущества:

- Оперативные поставки широкого спектра электронных компонентов отечественного и импортного производства напрямую от производителей и с крупнейших мировых складов;
- Поставка более 17-ти миллионов наименований электронных компонентов;
- Поставка сложных, дефицитных, либо снятых с производства позиций;
- Оперативные сроки поставки под заказ (от 5 рабочих дней);
- Экспресс доставка в любую точку России;
- Техническая поддержка проекта, помощь в подборе аналогов, поставка прототипов;
- Система менеджмента качества сертифицирована по Международному стандарту ISO 9001;
- Лицензия ФСБ на осуществление работ с использованием сведений, составляющих государственную тайну;
- Поставка специализированных компонентов (Xilinx, Altera, Analog Devices, Intersil, Interpoint, Microsemi, Aeroflex, Peregrine, Syfer, Eurofarad, Texas Instrument, Miteq, Cobham, E2V, MA-COM, Hittite, Mini-Circuits, General Dynamics и др.);

Помимо этого, одним из направлений компании «ЭлектроПласт» является направление «Источники питания». Мы предлагаем Вам помощь Конструкторского отдела:

- Подбор оптимального решения, техническое обоснование при выборе компонента;
- Подбор аналогов;
- Консультации по применению компонента;
- Поставка образцов и прототипов;
- Техническая поддержка проекта;
- Защита от снятия компонента с производства.



Как с нами связаться

Телефон: 8 (812) 309 58 32 (многоканальный)

Факс: 8 (812) 320-02-42

Электронная почта: org@eplast1.ru

Адрес: 198099, г. Санкт-Петербург, ул. Калинина, дом 2, корпус 4, литера А.