

3M™ High-Speed Card-Edge CONNECTOR, SPD08

FIG. 1
FOR POSITIONS 020, 040, 060,
W/O LATCH OPTION
(SHOWN: SPD08-020-RB-TR)



NOTES:

- MATERIAL:
HOUSING: GLASS FILLED LCP, BLACK, UL 94V-0.
LATCH: GLASS FILLED LCP, BEIGE, UL 94V-0.
SOLDER TAB: COPPER ALLOY.
CONTACT: COPPER ALLOY.
- FINISH:
GOLD PLATING ON CONTACT MATING AREA,
3~5um MATTE TIN ON SOLDER TAIL,
1.27um NICKEL UNDER PLATED.
- RATING:
CURRENT: 3.0A @ 30°C TEMPERATURE RISE.
VOLTAGE: 50V AC.
TEMPERATURE: -55 TO 125°C.
CONTACT RESISTANCE: 50mΩ MAX.
CHARACTERISTIC IMPEDANCE: 50Ω SINGLE-ENDED,
100Ω DIFFERENTIAL.
BANDWIDTH: 7.5GHz (RATED @ -3dB INSERTION LOSS,
30mm STACK HEIGHT)
- ROHS COMPLIANT.
- PART NUMBERING INFORMATION:

SPD08-XXX-X-XX-XX

NO OF POSITIONS
020, 040, 060 (SEE FIG. 1, 3)
064, 080, 100, 120, 140,
160, 180, 200 (SEE FIG. 2, 4)

PACKAGING OPTION
BLANK= TRAY
TR= TAPE & REEL

PLATING OPTION
RB= 0.76um GOLD
RA= 0.25um GOLD

LATCHING OPTION
BLANK= W/O LATCH (SEE FIG. 1, 2)
L = WITH LATCH (SEE FIG. 3, 4)

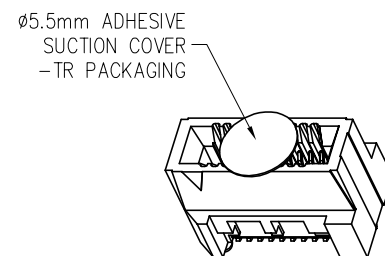
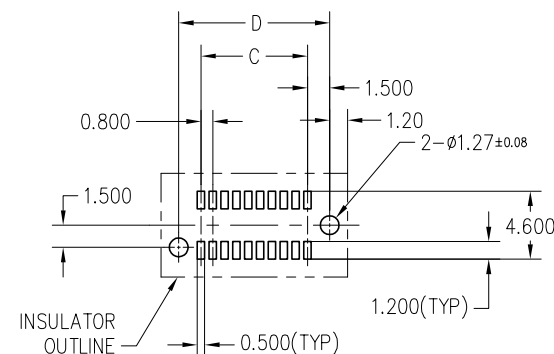
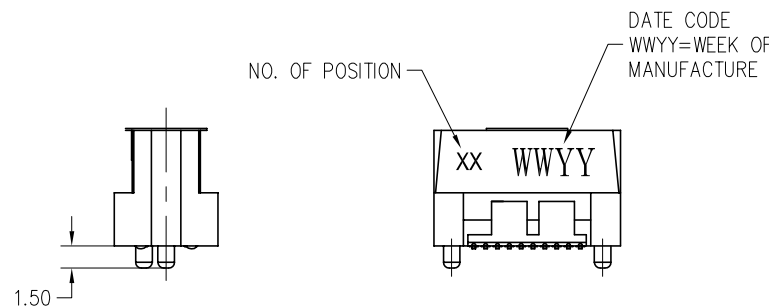
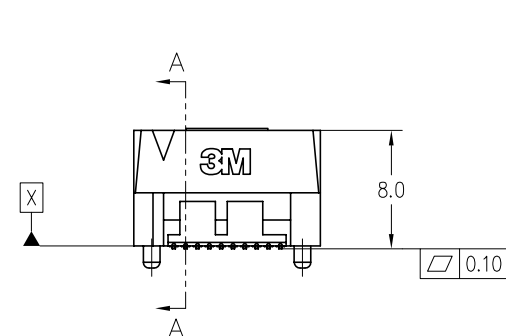

POS.	DIMENSIONS				
	A	B	C	D	AB
20*	12.60	9.40	7.200	10.20	9.25
40	20.60	17.40	15.200	18.20	17.25
60	28.60	25.40	23.200	26.20	25.25

* TOOLED SIZE

DESIGN REFERENCE	NEXT ASSEMBLY	REV	ECO	ISSUE DATE AND DESCRIPTION	DRFT	CHKD
				DATE 05/11/11		
DISTRIBUTION CODES		DRFT	K.D. LIU	DATE	MFG	DATE
		CHKD		DATE	APPLY	DATE
DIVISION ESD	DIVISION CODE	© 3M COPYRIGHT This document is the copyrighted property of the 3M Company and may not be reproduced without 3M written permission or used for other than 3M authorized purposes.				
DO NOT SCALE DRAWING	SCALE 2:1	TOLERANCES EXCEPT AS NOTED INCHES .0 ± .00 ± .000 ± .0000 ± MILLIMETERS 0 ± 0.50 .0 ± 0.20 .00 ± 0.10 .000 ± 0.05 ANGLES ± 3°				
THIRD ANGLE PROJECTION		TITLE SPD08 HIGH SPEED CARD EDGE CONNECTOR, 0.8MM PITCH SMT				
INTERPRET PER ASME Y14.5 - 1994		CAGE NUMBER C DRAWING NO. 78-5100-2420-7 REV. A				
MAX SURFACE ROUGHNESS □ ALL SURFACES ✓ MARKED ONLY		MODEL DET. LISTS □ YES □ NO SHT 1 OF 4				

3M™ High-Speed Card-Edge CONNECTOR, SPD08

FIG. 2
FOR POSITIONS 064, 080, 100, 120,
140, 160, 180, 200, W/O LATCH OPTION
(SHOWN: SPD08-080-RB)

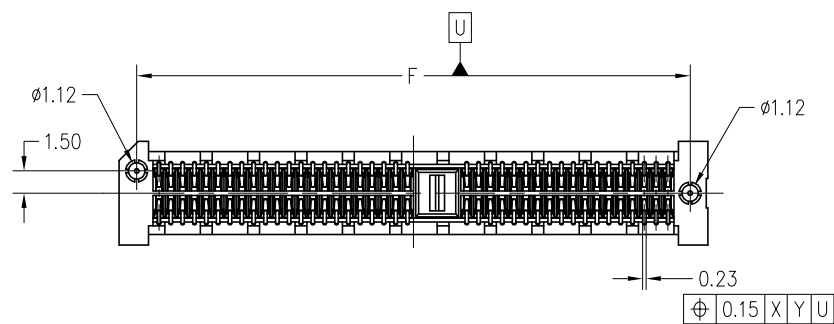

POS.	DIMENSIONS							
	A	B	C	D	E	F	AB	AC
64	33.40	30.20	16.70	13.600	28.000	31.00	30.05	16.625
80*	39.80	36.60	19.90	16.800	34.400	37.40	36.45	19.825
100	47.80	44.60	23.90	20.800	42.400	45.40	44.45	23.825
120	55.80	52.60	27.90	24.800	50.400	53.40	52.45	27.825
140	63.80	60.60	27.90	24.800	58.400	61.40	60.45	27.825
160	71.80	68.60	27.90	24.800	66.400	69.40	68.45	27.825
180	79.80	76.60	27.90	24.800	74.400	77.40	76.45	27.825
200	87.80	84.60	27.90	24.800	82.400	85.40	84.45	27.825

* TOOLED SIZE

DESIGN REFERENCE	NEXT ASSEMBLY	REV	ECO	ISSUE DATE AND DESCRIPTION	DRFT	CHKD
DISTRIBUTION CODES		DRFT	K.D. LIU	DATE 05/11/11	MFG	DATE
		CHKD		DATE	APPLY	DATE
DIVISION ESD	DIVISION CODE	© 3M COPYRIGHT This document is the copyrighted property of the 3M Company and may not be reproduced without 3M written permission or used for other than 3M authorized purposes.				
DO NOT SCALE DRAWING	SCALE 2:1	TOLERANCES EXCEPT AS NOTED INCHES .0 ± .00 ± .000 ± .0000 ± MILLIMETERS 0 ± 0.50 .0 ± 0.20 .00 ± 0.10 .000 ± 0.05 ANGLES ± 3°				
THIRD ANGLE PROJECTION	INTERPRET PER ASME Y14.5 - 1994	TITLE SPD08 HIGH SPEED CARD EDGE CONNECTOR, 0.8MM PITCH SMT				
MAX SURFACE ROUGHNESS	<input type="checkbox"/> ALL SURFACES <input checked="" type="checkbox"/> MARKED ONLY	CAGE NUMBER	SIZE C	DRAWING NO.	REV. A	
		78-5100-2420-7			SHT 2 OF 4	

3M™ High-Speed Card-Edge CONNECTOR, SPD08

FIG. 3
FOR POSITIONS 020, 040, 060,
WITH LATCH OPTION
(SHOWN: SPD08-040-L-RB)

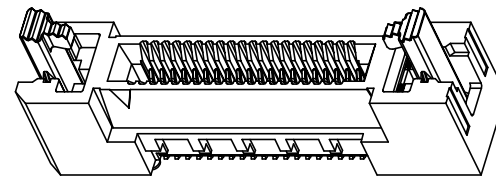
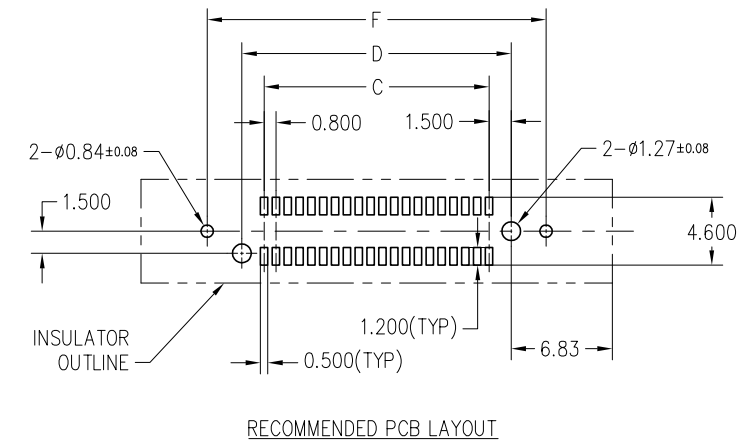
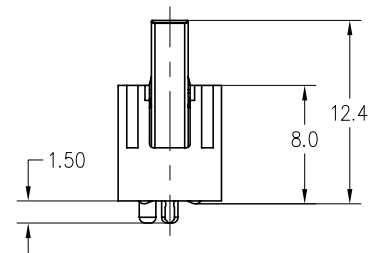
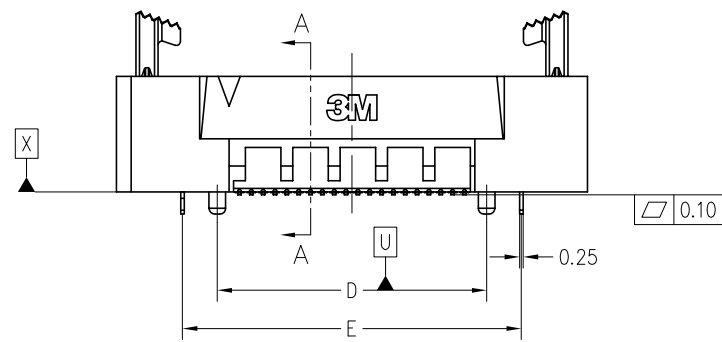
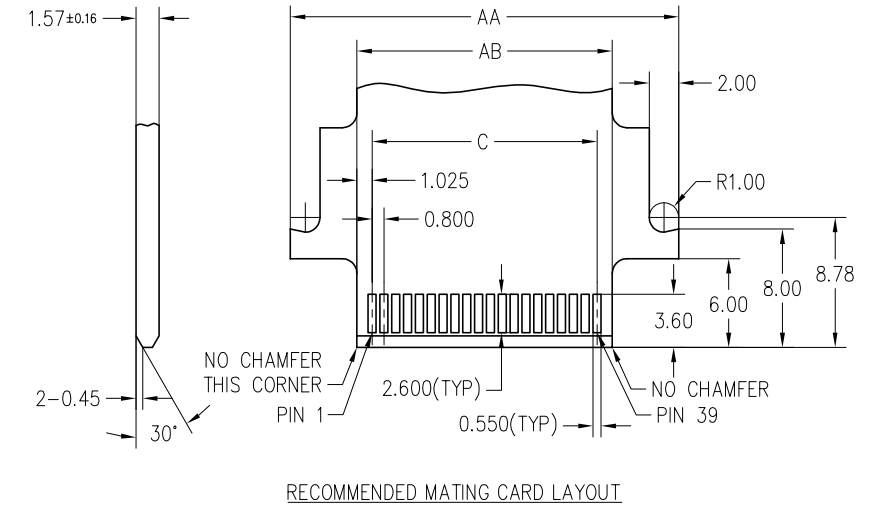
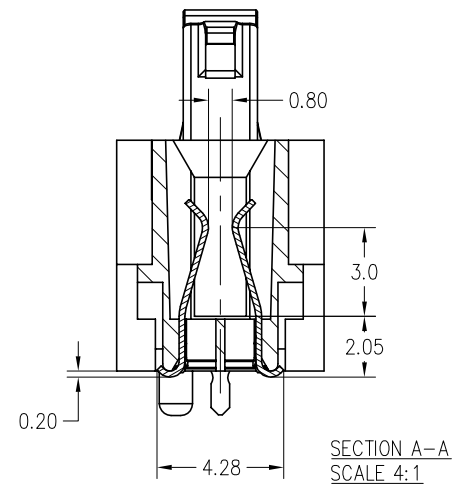

POS.	DIMENSIONS						
	A	B	C	D	E	AA	AB
20	23.85	9.40	7.200	10.20	12.90	18.25	9.25
40	31.85	17.40	15.200	18.20	20.90	26.25	17.25
60	39.85	25.40	23.200	26.20	28.90	34.25	25.25

* TOOLED SIZE

DESIGN REFERENCE	NEXT ASSEMBLY	REV	ECO	ISSUE DATE AND DESCRIPTION	DRFT	CHKD
DISTRIBUTION CODES		DRFT	K.D. LIU	DATE 05/11/11	MFG	DATE
		CHKD		DATE	APPLY	DATE
DIVISION ESD	DIVISION CODE	© 3M COPYRIGHT This document is the copyrighted property of the 3M Company and may not be reproduced without 3M written permission or used for other than 3M authorized purposes.				
DO NOT SCALE DRAWING	SCALE 2:1					
TOLERANCES EXCEPT AS NOTED		TITLE				
INCHES .0 ± .00 ± .000 ± .0000 ±		SPD08 HIGH SPEED CARD EDGE CONNECTOR, 0.8MM PITCH SMT				
MILLIMETERS 0 ± 0.50 .0 ± 0.20 .00 ± 0.10 .000 ± 0.05						
THIRD ANGLE PROJECTION INTERPRET PER ASME Y14.5 - 1994		CAGE NUMBER	SIZE C	DRAWING NO.	REV.	
MAX SURFACE ROUGHNESS □ ALL SURFACES ✓ □ MARKED ONLY				78-5100-2420-7	A	
ANGLES ± 3°		MODEL		DET. LISTS	□ YES □ NO	SHT 3 OF 4

3M™ High-Speed Card-Edge CONNECTOR, SPD08

FIG. 4
FOR POSITIONS 064, 080, 100, 120,
140, 160, 180, 200, WITH LATCH OPTION
(SHOWN: SPD08-080-L-RB-TR)

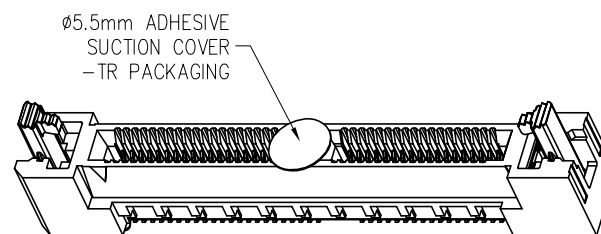

POS.	DIMENSIONS									
	A	B	C	D	E	F	G	AA	AB	AC
64	44.65	30.20	16.70	13.600	28.000	31.00	35.70	39.05	30.05	16.625
80*	51.05	36.60	19.90	16.800	34.400	37.40	42.10	45.45	36.45	19.825
100	59.05	44.60	23.90	20.800	42.400	45.40	50.10	53.45	44.45	23.825
120	67.05	52.60	27.90	24.800	50.400	53.40	58.10	61.45	52.45	27.825
140	75.05	60.60	27.90	24.800	58.400	61.40	66.10	69.45	60.45	27.825
160	83.05	68.60	27.90	24.800	66.400	69.40	74.10	77.45	68.45	27.825
180	91.05	76.60	27.90	24.800	74.400	77.40	82.10	85.45	76.45	27.825
200	99.05	84.60	27.90	24.800	82.400	85.40	90.10	93.45	84.45	27.825

* TOOLED SIZE

DESIGN REFERENCE	NEXT ASSEMBLY	REV	ECO	ISSUE DATE AND DESCRIPTION	DRFT	CHKD
DISTRIBUTION CODES		DRFT	K.D. LIU	DATE 05/11/11	MFG	DATE
		CHKD		DATE	APPLY	DATE
DIVISION ESD	DIVISION CODE	© 3M COPYRIGHT This document is the copyrighted property of the 3M Company and may not be reproduced without 3M written permission or used for other than 3M authorized purposes.				
DO NOT SCALE DRAWING	SCALE 2:1	TOLERANCES EXCEPT AS NOTED INCHES .0 ± .00 ± .000 ± .0000 ± MILLIMETERS 0 ± 0.50 .0 ± 0.20 .00 ± 0.10 .000 ± 0.05 ANGLES ± 3°				
THIRD ANGLE PROJECTION	INTERPRET PER ASME Y14.5 - 1994	TITLE SPD08 HIGH SPEED CARD EDGE CONNECTOR, 0.8MM PITCH SMT				
MAX SURFACE ROUGHNESS	<input type="checkbox"/> ALL SURFACES <input checked="" type="checkbox"/> MARKED ONLY	CAGE NUMBER	SIZE C	DRAWING NO.	78-5100-2420-7	REV. A
		MODEL		DET. LISTS	<input type="checkbox"/> YES <input type="checkbox"/> NO	SHT 4 OF 4



Компания «ЭлектроПласт» предлагает заключение долгосрочных отношений при поставках импортных электронных компонентов на взаимовыгодных условиях!

Наши преимущества:

- Оперативные поставки широкого спектра электронных компонентов отечественного и импортного производства напрямую от производителей и с крупнейших мировых складов;
- Поставка более 17-ти миллионов наименований электронных компонентов;
- Поставка сложных, дефицитных, либо снятых с производства позиций;
- Оперативные сроки поставки под заказ (от 5 рабочих дней);
- Экспресс доставка в любую точку России;
- Техническая поддержка проекта, помощь в подборе аналогов, поставка прототипов;
- Система менеджмента качества сертифицирована по Международному стандарту ISO 9001;
- Лицензия ФСБ на осуществление работ с использованием сведений, составляющих государственную тайну;
- Поставка специализированных компонентов (Xilinx, Altera, Analog Devices, Intersil, Interpoint, Microsemi, Aeroflex, Peregrine, Syfer, Eurofarad, Texas Instrument, Miteq, Cobham, E2V, MA-COM, Hittite, Mini-Circuits, General Dynamics и др.);

Помимо этого, одним из направлений компании «ЭлектроПласт» является направление «Источники питания». Мы предлагаем Вам помощь Конструкторского отдела:

- Подбор оптимального решения, техническое обоснование при выборе компонента;
- Подбор аналогов;
- Консультации по применению компонента;
- Поставка образцов и прототипов;
- Техническая поддержка проекта;
- Защита от снятия компонента с производства.



Как с нами связаться

Телефон: 8 (812) 309 58 32 (многоканальный)

Факс: 8 (812) 320-02-42

Электронная почта: org@eplast1.ru

Адрес: 198099, г. Санкт-Петербург, ул. Калинина, дом 2, корпус 4, литера А.