



HITEK POWER® MSQ SERIES
MASS SPECTROMETRY POWER SUPPLY MODULES





MSQ SERIES

The MSQ series consists of quad output modules for use in high leakage electrostatic lens applications. They provide reliable and consistent operation over long working periods.

MODULAR DESIGNS, CUSTOM SOLUTIONS

The modular design of AE high voltage products for mass spectrometry enables an array of performance features and combinations. From simple options, such as cable length and connector type, to complete custom designs, we deliver solutions that precisely fulfill your specific requirements.

FEATURES

- › Output power: 85 W
- › Output voltage: ± 430 V to ± 1.35 kV
- › Quad outputs
- › Ripple: $< 0.05\%$ peak to peak
- › Temperature coefficient: 250 ppm/ $^{\circ}$ C
- › Stability: 0.25% per hour after one hour warm up
- › Each output individually protected
- › High reliability
- › Screened case for low magnetic radiation
- › Compact design

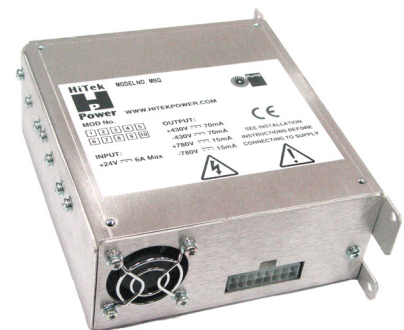

PROVEN POWER-CONVERSION TOPOLOGIES, CONTROL METHODS, AND MECHANICAL EXPERTISE FEATURE

SPECIFICATIONS

Output Power	85 kW, max (total of 4 outputs)
Output Voltage	±430 V to ±1.35 kV, depending on model
Output Current	Up to 70 mA, depending on model
Output Polarity	Not selectable
Input Voltage	+24 VDC ±10%
Input Current	6 A, max
Line Regulation	< 0.5% for a 1 V input voltage change
Load Regulation	< ±1% for output 1, ±4% for outputs 2, 3, and 4
Ripple	< 0.05% peak to peak
Voltage Control	Output voltages are fixed.
Current Control	Fixed at approximately 110 to 130% of max
Stability	0.25% per hour after one hour warmup
Temperature Coefficient	250 ppm/°C at max output voltage
Cooling	Forced cooled (integrated fan)
Protection	The units are fully protected against over voltage, thermal, and short circuit on all outputs.
Operational Temperature	10 to 50°C (50 to 122°F)
Storage/Transport Temperature	-20 to 85°C (-4 to 185°F)
Operational Altitude	Sea level to 2000 m (6500')
Storage/Transport Altitude	Sea level to 18000 m (59,055')
Reliability	MTBF > 50,000 hours
Humidity	80% max relative humidity up to 31°C (88°F), reducing linearly to 50% at 40°C (104°F); non-condensing (ref EN61010-1)
Safety	Meets the requirements of the Low Voltage Directive, 2006/95/EC by complying with BS EN61010-1:2010 when installed as a component part of compliant equipment. Units are CE marked accordingly.
RoHS	Meets the requirements of EU Directive 2011/65/EC on the Restriction of use of certain Hazardous Substances in Electrical and Electronic Equipment (RoHS).
Construction	A fabricated aluminum alloy case is used for good heat dissipation and screening.

Mechanical Specification

Dimensions	168 mm x 136 mm x 57 mm (6.6" x 5.35" x 2.24")
Weight	0.8 kg (1.76 lb)
Casing	Aluminum, clear non-chrome passivate finish
Output Cable	Unterminated URM76



OUTPUT AND ORDERING INFORMATION

Model	Output 1	Output 2	Output 3	Output 4
MSQ-801	+430 V, 70 mA	-430 V, 70 mA	+800 V, 15 mA	-800 V, 15 mA
MSQ-142	+430 V, 50 mA	-430 V, 50 mA	+1.35 kV, 15 mA	-1.35 kV, 15 mA

INTERFACE CONNECTIONS

Molex Minifir 39-29-1168 16-Way Connector

Note: The input and output 0 V are connected together and also connected to the chassis.

PIN	FUNCTION
1	--
2	--
3	--
4	+24 V input
5	0 V input
6	--
7	--
8	--
9	Output 3
10	--
11	Output 1
12	0 V output
13	0 V input
14	Output 2
15	--
16	Output 4

Drawing dimensions are in mm (inches).

Design developments may result in specification changes.

6 x M3 FIXINGS THIS SIDE - POSITIONS SHOWN BELOW:

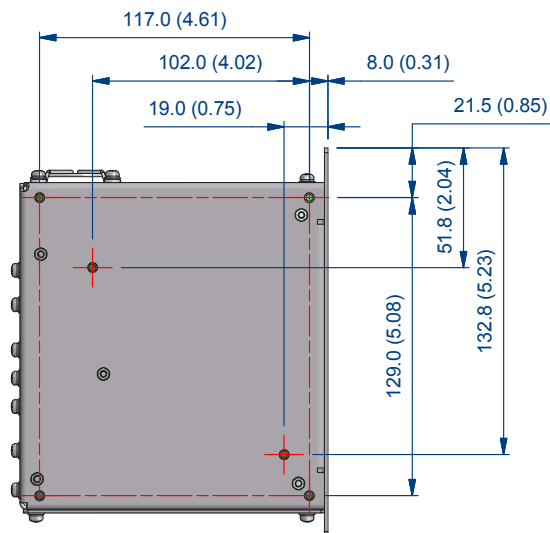

DIMENSIONS mm (in)

4 x M3 FIXINGS THIS SIDE - POSITIONS SHOWN BELOW:

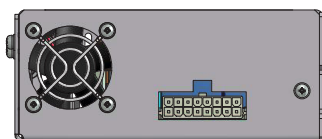
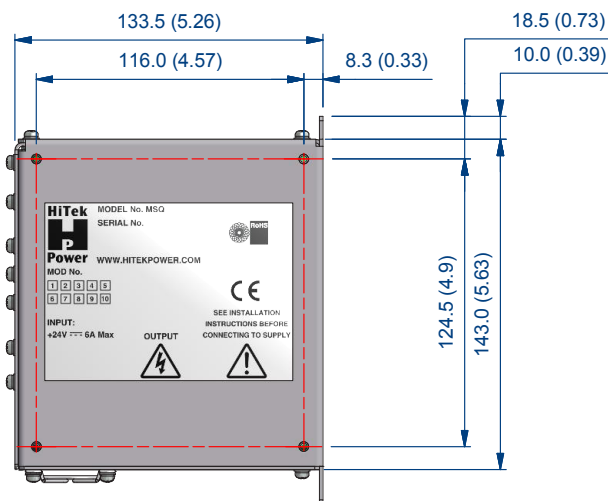

4 FIXING POSITIONS THIS SIDE POSITIONS SHOWN BELOW:

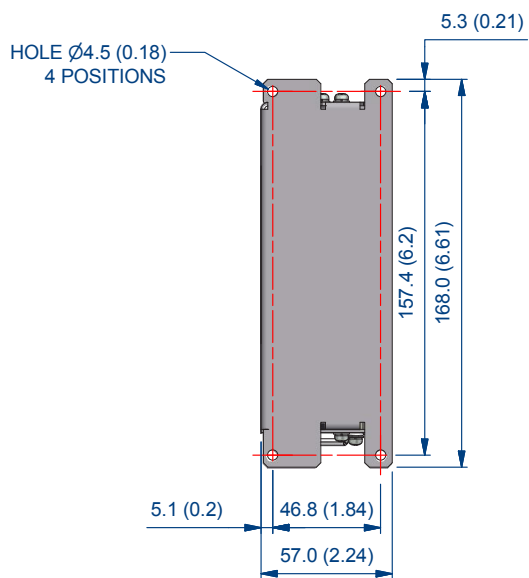



Advanced Energy Industries, Inc.

HiTek Power Ltd.*
Hawthorn Road
Littlehampton
West Sussex
BN17 7LT
United Kingdom

+44 0 1903 712400

hvsales@aei.com
advanced-energy.com



Компания «ЭлектроПласт» предлагает заключение долгосрочных отношений при поставках импортных электронных компонентов на взаимовыгодных условиях!

Наши преимущества:

- Оперативные поставки широкого спектра электронных компонентов отечественного и импортного производства напрямую от производителей и с крупнейших мировых складов;
- Поставка более 17-ти миллионов наименований электронных компонентов;
- Поставка сложных, дефицитных, либо снятых с производства позиций;
- Оперативные сроки поставки под заказ (от 5 рабочих дней);
- Экспресс доставка в любую точку России;
- Техническая поддержка проекта, помощь в подборе аналогов, поставка прототипов;
- Система менеджмента качества сертифицирована по Международному стандарту ISO 9001;
- Лицензия ФСБ на осуществление работ с использованием сведений, составляющих государственную тайну;
- Поставка специализированных компонентов (Xilinx, Altera, Analog Devices, Intersil, Interpoint, Microsemi, Aeroflex, Peregrine, Syfer, Eurofarad, Texas Instrument, Miteq, Cobham, E2V, MA-COM, Hittite, Mini-Circuits, General Dynamics и др.);

Помимо этого, одним из направлений компании «ЭлектроПласт» является направление «Источники питания». Мы предлагаем Вам помощь Конструкторского отдела:

- Подбор оптимального решения, техническое обоснование при выборе компонента;
- Подбор аналогов;
- Консультации по применению компонента;
- Поставка образцов и прототипов;
- Техническая поддержка проекта;
- Защита от снятия компонента с производства.



Как с нами связаться

Телефон: 8 (812) 309 58 32 (многоканальный)

Факс: 8 (812) 320-02-42

Электронная почта: org@eplast1.ru

Адрес: 198099, г. Санкт-Петербург, ул. Калинина, дом 2, корпус 4, литера А.