

Type SCM Single/Dual IGBT Snubber Capacitor Modules

High Peak Current Snubber with Integrated Hyperfast Diode

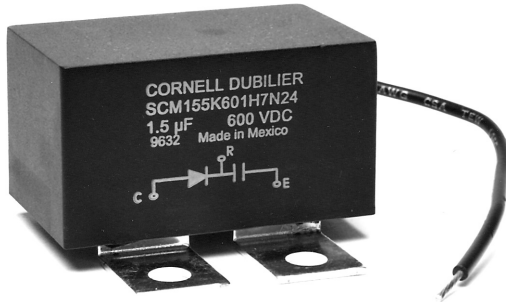

Use style SCM as a discharge restrictive de-coupling to protect dual IGBT modules from overvoltage, Figure 1. Style SCM may also be used as an "N" or "P" type snubber component for a clamp snubber where single IGBT modules are used, figure 2.

Highlights

- Direct mount to the IGBT module
- Low inductance
- Low Loss
- Hyperfast diodes integrated into package
- Self healing
- Other terminal spacing, capacitance values and voltage ratings, also available upon request.

Specifications

Capacitance Range	0.47 to 2.0 μ F
Capacitance Tolerance	\pm 10% (K) standard, \pm 5% (J) optional
Rated Voltage	600 to 1200 Vdc
Operating Temperature Range with Ripple	-55 $^{\circ}$ C to 70 $^{\circ}$ C
RoHS Compliant	

Dimensions

Construction Details	
Case Material	Plastic UL94V-0
Resin Material	Dry Resin UL94V-0
Terminal Material	Tin Plated Copper

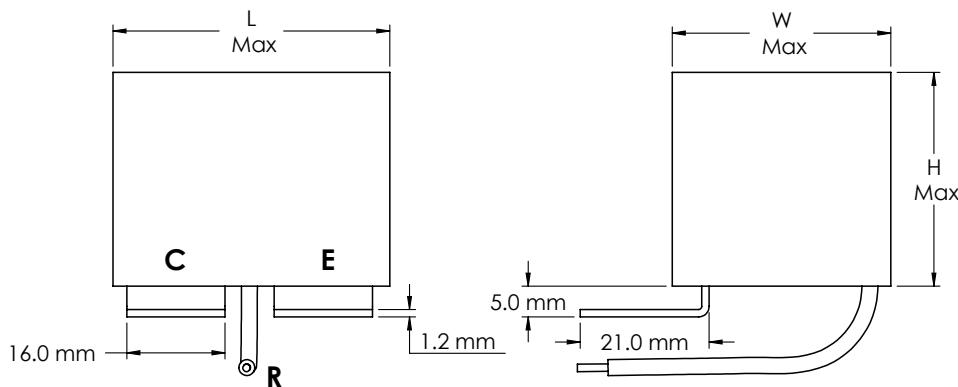

Wire: UL1015
AWG 18
200 mm Min

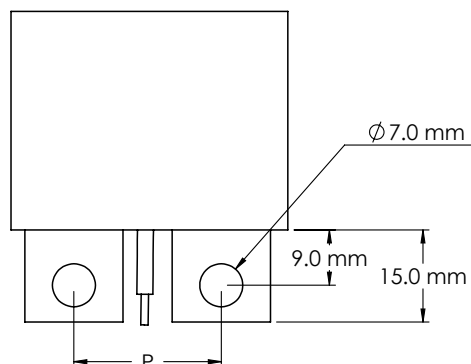

N Type

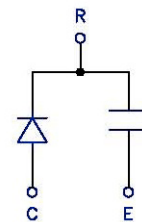

P Type

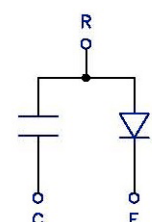

Type SCM Single/Dual IGBT Snubber Capacitor Modules

High Peak Current Snubber with Integrated Hyperfast Diode

Part Numbering System

SCM	105	K	122	H1	N	24	-F
Series Type Designation	Capacitance in μF	Tolerance Code	Voltage	Diode Rating	Polarity	Lug Spacing	RoHS Compliant Indicator
	104=0.1 μF	J = $\pm 5\%$	601 = 600 Vdc		N or P Type	24=24mm	
	105=1 μF	K = $\pm 10\%$	122 = 1200 Vdc			28=28mm	
	225=2.2 μF		202 = 2000 Vdc			29=29mm	

Ratings

Note: Other ratings, sizes and performance specification available upon request. Contact us.

Catalog Part Number	Typical Application IGBT Module				Diode Characteristics								Dimensions			
	Cap	S=Single	Ic	Vce	Ipk	Ipk	Dimensions									
	(μF)	D=Dual	(A)	(V)	surge	rep	W	L	H	P	(mm)	(mm)	(mm)	(mm)		
SCM474K601H7N29-F	0.47	S	200-300	600	N	600	30	0.040	300	70	43.82	55.88	34.04	29		
SCM474K601H7P29-F	0.47	S	200-300	600	P	600	30	0.040	300	70	43.82	55.88	34.04	29		
SCM105K601H7N24-F	1.00	D	100-200	600	N	600	30	0.040	300	70	38.10	47.63	31.75	24		
SCM105K601H7P24-F	1.00	D	100-200	600	P	600	30	0.040	300	70	38.10	47.63	31.75	24		
SCM105K601H5N29-F	1.00	S	300-400	600	N	600	50	0.045	500	100	46.36	56.52	38.10	29		
SCM105K601H5P29-F	1.00	S	300-400	600	P	600	50	0.045	500	100	46.36	56.52	38.10	29		
SCM155K601H7N24-F	1.50	D	200-300	600	N	600	30	0.040	300	70	34.29	55.88	30.48	24		
SCM155K601H7P24-F	1.50	D	200-300	600	P	600	30	0.040	300	70	38.10	47.63	31.75	24		
SCM205K601H5N24-F	2.00	D	300-400	600	N	600	50	0.045	500	100	43.82	55.88	34.04	24		
SCM205K601H5P24-F	2.00	D	300-400	600	P	600	50	0.045	500	100	43.82	55.88	34.04	24		
SCM205K601H2N29-F	2.00	S	400-600	600	N	600	100	0.050	1000	200	46.36	56.52	38.10	29		
SCM205K601H2P29-F	2.00	S	400-600	600	P	600	100	0.050	1000	200	46.36	56.52	38.10	29		
SCM474K122H8N29-F	0.47	S	200-300	1200	N	1200	30	0.065	300	60	34.29	55.88	30.48	29		
SCM474K122H8P29-F	0.47	S	200-300	1200	P	1200	30	0.065	300	60	38.10	47.63	31.75	29		
SCM105K122H8N24-F	1.00	D	100-200	1200	N	1200	30	0.065	300	60	44.45	63.50	37.34	24		
SCM105K122H8P24-F	1.00	D	100-200	1200	P	1200	30	0.065	300	60	44.45	63.50	37.34	24		
SCM105K122H4N29-F	1.00	S	300-400	1200	N	1200	50	0.085	500	100	43.82	55.88	34.04	29		
SCM105K122H4P29-F	1.00	S	300-400	1200	P	1200	50	0.085	500	100	46.36	56.52	38.10	29		
SCM155K122H8N24-F	1.50	D	200-300	1200	N	1200	30	0.065	300	60	44.45	63.50	37.34	24		
SCM155K122H8P24-F	1.50	D	200-300	1200	P	1200	30	0.065	300	60	46.36	56.52	38.10	24		
SCM205K122H4N24-F	2.00	D	300-400	1200	N	1200	50	0.065	500	100	53.98	63.50	43.18	24		
SCM205K122H4P24-F	2.00	D	300-400	1200	P	1200	50	0.065	500	100	53.98	63.50	43.18	24		
SCM205K122H1N29-F	2.00	S	400-600	1200	N	1200	100	0.090	1000	200	53.98	63.50	43.18	29		
SCM205K122H1P29-F	2.00	S	400-600	1200	P	1200	100	0.090	1000	200	53.98	63.50	43.18	29		

Ipk surge at 25 °C and Ipk repetitive at 25 °C and 20 kHz.

Type SCM Single/Dual IGBT Snubber Capacitor Modules

High Peak Current Snubber with Integrated Hyperfast Diode

Typical Applications

Discharge Restrictive De-coupling

The circuit in Figure 1 operates on the same principles as the de-coupling capacitor, but only during turn-off switching. As the IGBT turns off, energy trapped in the loop inductance is transferred to the capacitor. The diode blocks oscillations from occurring and excess charge on the capacitor is discharged through the external resistor.

- 1 or 2 wire taps for connecting external resistor
- Flame resistant case and epoxy, meets UL 94V0
- Other terminal pitches and capacitance values available.

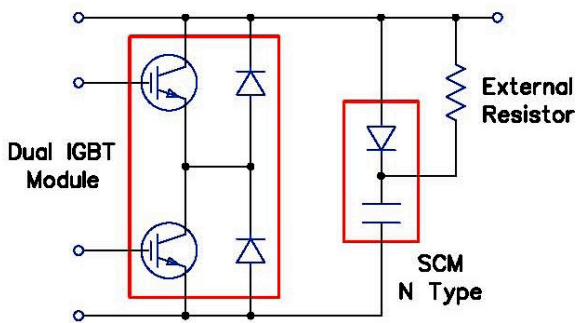

Figure 1
Style SCM Discharge restrictive decoupling used to protect dual IGBT modules

RCD Clamp

The function of this snubber is similar to a clamp, Figure 2. At turn-off, the snubber diode is forward biased and the snubber is activated. The energy trapped in the stray inductance is absorbed by the snubber capacitor. During turn-on the snubber caps that were fully charged to bus voltage have a discharge path through the forward biased free-wheel diode, the IGBT, and the snubber resistors. This reduces the reverse recovery voltage transient.

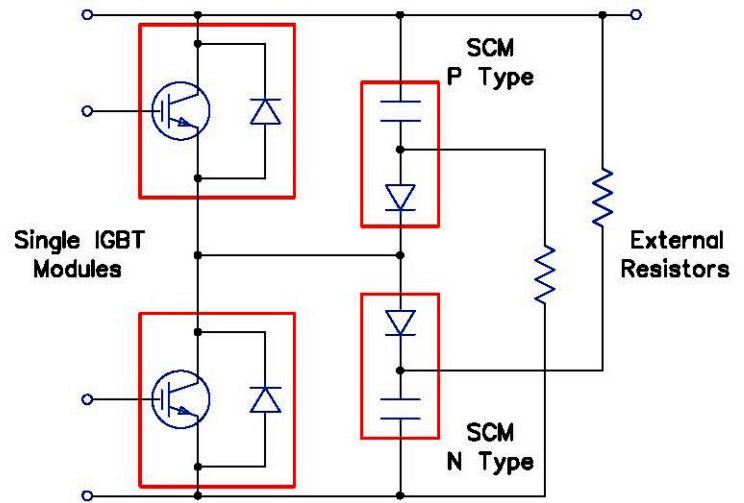

Figure 2
Style SCM "P" type and "N" type used as a clamp to protect an inverter using two "single" IGBT modules



Компания «ЭлектроПласт» предлагает заключение долгосрочных отношений при поставках импортных электронных компонентов на взаимовыгодных условиях!

Наши преимущества:

- Оперативные поставки широкого спектра электронных компонентов отечественного и импортного производства напрямую от производителей и с крупнейших мировых складов;
- Поставка более 17-ти миллионов наименований электронных компонентов;
- Поставка сложных, дефицитных, либо снятых с производства позиций;
- Оперативные сроки поставки под заказ (от 5 рабочих дней);
- Экспресс доставка в любую точку России;
- Техническая поддержка проекта, помощь в подборе аналогов, поставка прототипов;
- Система менеджмента качества сертифицирована по Международному стандарту ISO 9001;
- Лицензия ФСБ на осуществление работ с использованием сведений, составляющих государственную тайну;
- Поставка специализированных компонентов (Xilinx, Altera, Analog Devices, Intersil, Interpoint, Microsemi, Aeroflex, Peregrine, Syfer, Eurofarad, Texas Instrument, Miteq, Cobham, E2V, MA-COM, Hittite, Mini-Circuits, General Dynamics и др.);

Помимо этого, одним из направлений компании «ЭлектроПласт» является направление «Источники питания». Мы предлагаем Вам помощь Конструкторского отдела:

- Подбор оптимального решения, техническое обоснование при выборе компонента;
- Подбор аналогов;
- Консультации по применению компонента;
- Поставка образцов и прототипов;
- Техническая поддержка проекта;
- Защита от снятия компонента с производства.



Как с нами связаться

Телефон: 8 (812) 309 58 32 (многоканальный)

Факс: 8 (812) 320-02-42

Электронная почта: org@eplast1.ru

Адрес: 198099, г. Санкт-Петербург, ул. Калинина, дом 2, корпус 4, литера А.