

RoHS Recast Compliant

SATA-Disk Module 5A-M

SDM5A-M 22P/180D Product Specifications (Toshiba 15nm)

January 7, 2016

Version 1.0



Apacer Technology Inc.

1F, No.32, Zhongcheng Rd., Tucheng Dist., New Taipei City, Taiwan, R.O.C

Tel: +886-2-2267-8000 Fax: +886-2-2267-2261

www.apacer.com

Features:

- **Standard Serial ATA Interface**
 - Serial ATA Revision 3.1
 - SATA 6.0 Gbps interface
 - ATA-8 command set
 - Backward compatible with SATA 1.5/3.0 Gbps
- **Capacities**
 - 8, 16, 32, 64 GB
- **Performance***
 - Burst read/write: 600 MB/sec
 - Sustained read: up to 245 MB/sec
 - Sustained write: up to 75 MB/sec
- **Flash Management**
 - Built-in hardware ECC
 - Static/dynamic wear-leveling
 - Flash bad-block management
 - S.M.A.R.T.
 - Power failure management
 - ATA secure erase
 - TRIM
- **NAND Flash Type: MLC**
- **MTBF: >1,000,000 hours**
- **Temperature Range**
 - Operating:
 - Standard: 0°C to 70°C
 - Extended: -40°C to 85°C
 - Storage: -40°C to 100°C
- **Supply Voltage**
 - 5.0 V ± 5%
- **Power Consumption***
 - Active mode: 205 mA
 - Idle mode: 80 mA
- **Connector Type**
 - 7-pin SATA signal connector
 - 15-pin SATA power connector
- **Form Factor**
 - SATA Disk Module
- **Shock & Vibration****
 - Shock: 1,500 G
 - Vibration: 15 G
- **RoHS Recast Compliant**
 - Complies with 2011/65/EU standard

*Varies from capacities. The values for performances and power consumptions presented are typical and may vary depending on flash configurations or platform settings. The term idle refers to the standby state of the device.

**Non-operating

Table of Contents

1. General Description	3
2. Functional Block Diagram	3
3. Pin Assignments.....	4
4. Product Specifications.....	6
4.1 Capacity.....	6
4.2 Performance	6
4.3 Environmental Specifications	7
4.4 Mean Time Between Failures (MTBF)	7
4.5 Certification and Compliance	7
5. Flash Management.....	8
5.1 Error Correction/Detection.....	8
5.2 Bad Block Management	8
5.3 Wear Leveling.....	8
5.4 Power Failure Management	8
5.5 ATA Secure Erase.....	8
5.6 TRIM.....	9
6. Software Interface	10
6.1 Command Set.....	10
6.2 S.M.A.R.T.	10
7. Electrical Specifications	12
8. Physical Characteristics.....	13
8.1 Dimensions.....	13
9. Product Ordering Information.....	14
9.1 Product Code Designations.....	14
9.2 Valid Combinations.....	15

1. General Description

Apacer's SDM5A-M (SATA Disk Module 5A-M) is our next generation disk-on-module (DOM) series that offers elevated speed boost and higher error correction capabilities. Built with SATA 6.0 Gb/s interface, SDM5A-M delivers higher performance in data transfer than its previous SDM selections, reaching up to 245 MB/s in read and 75 MB/s in write.

With its SATA interface compliance and compact size, this high-speed disk module defines an ideal balance of performance, capacities, reliability and cost. SDM5A-M comes in moderate capacities that are suitable to boot industrial applications and light operating systems for specific operations, while with some extra memory space for data storage. The architectural nature of SATA disk module provides higher resistance to external environmental influences and better flexibility for motherboard space.

Regarding data reliability, SDM5A-M is built in with powerful ECC engine that can correct up to 40 bits per 1KB data. In addition, the controller unit of this DOM device supports wear-leveling, SMART and power failure management for data integrity. With its trustable reliability, performance and cost effectiveness, Apacer's SDM5A-M is definitely the ideal storage or cache solution for embedded and industrial computers, servers and thin clients.

2. Functional Block Diagram

SDM5A-M includes the SATA and Flash Management controllers, and flash media, as well as the SATA standard interface. Figure 2-1 shows the functional block diagram.

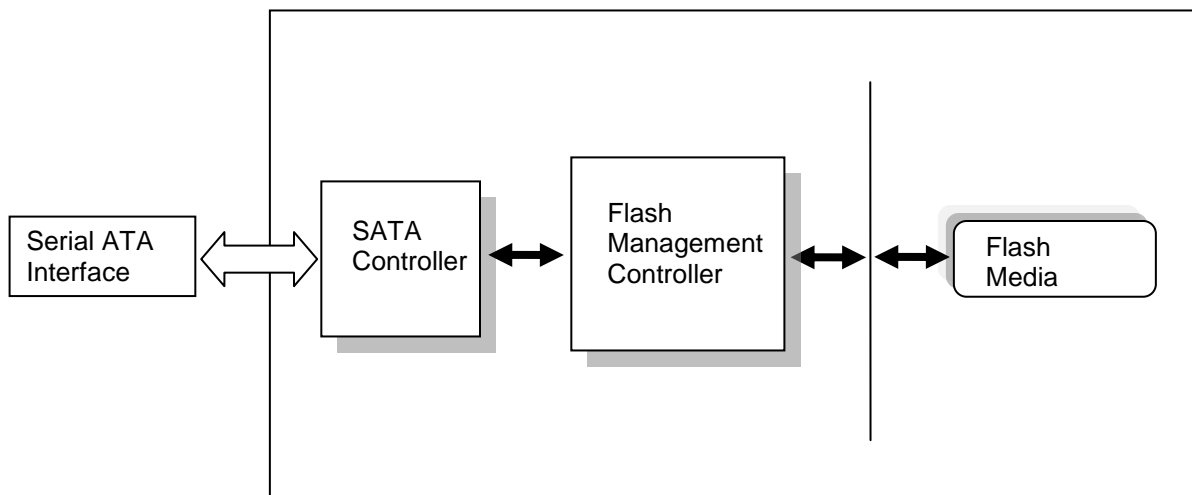

Figure 2-1: Functional Block Diagram

3. Pin Assignments

SATA Connectors

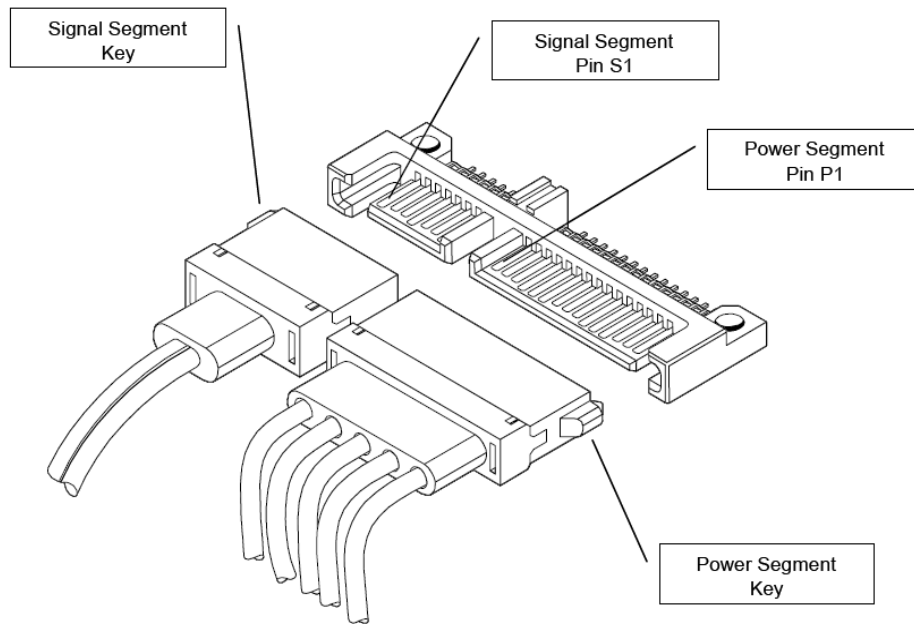

Table 3-1: Signal Segment

Pin	Type	Description
S1	GND	
S2	RxP	+ Differential Receive Signal
S3	RxN	- Differential Receive Signal
S4	GND	
S5	TxN	- Differential Transmit Signal
S6	TxP	+ Differential Transmit Signal
S7	GND	

Table 3-2: Power Segment

Pin	Signal/Description
P1	Unused (3.3V)
P2	Unused (3.3V)
P3	Unused (3.3V)
P4	Ground
P5	Ground
P6	Ground
P7	5V
P8	5V
P9	5V
P10	Ground
P11	DAS
P12	Ground
P13	Unused (12V)
P14	Unused (12V)
P15	Unused (12V)



Figure 3-1 SATA Cable/Connector Connection Diagram

The connector on the left represents the Host with TX/RX differential pairs connected to a cable. The connector on the right shows the Device with TX/RX differential pairs also connected to the cable. Notice also the ground path connecting the shielding of the cable to the Cable Receptacle.

4. Product Specifications

4.1 Capacity

Capacity specification of SDM5A-M is available as shown in Table 4-1. It lists the specific capacity and the default numbers of heads, sectors and cylinders for each product line.

Table 4-1: Capacity Specifications

Capacity	Total bytes*	Cylinders	Heads	Sectors	Max LBA
8 GB	8,012,390,400	15,525	16	63	15,649,200
16 GB	16,013,942,784	16,383	16	63	31,277,232
32 GB	32,017,047,552	16,383	16	63	62,533,296
64 GB	64,023,257,088	16,383	16	63	125,045,424

*Display of total bytes varies from file systems, which means not all of the bytes can be used for storage.

**Notes: 1 GB = 1,000,000,000 bytes; 1 sector = 512 bytes.

LBA count addressed in the table above indicates total user storage capacity and will remain the same throughout the lifespan of the device. However, the total usable capacity of the SSD is most likely to be less than the total physical capacity because a small portion of the capacity is reserved for device maintenance usages.

4.2 Performance

Performances of SDM5A-M are listed below in Table 4-2.

Table 4-2: Performance

Capacity	8 GB	16 GB	32 GB	64 GB
Performance				
Sustained read (MB/s)	105	215	210	245
Sustained write (MB/s)	24	48	42	75

Note: Results may differ from various flash configurations or host system setting.

4.3 Environmental Specifications

Environmental specification of SDM5A-M product family follows the MIL-STD-810 standards is available as shown in Table 4-3.

Table 4-3 SDM5A-M Environmental Specifications

Item	Specifications
Operating temp.	0°C to 70°C (Standard); -40°C to 85°C (Extended)
Non-operating temp.	-40°C to 100°C
Operating vibration	20~2,000(Hz), 7.69 (Grms), random wave, X, Y, Z axis
Non-operating vibration	10~2,000(Hz), 15(G), sine wave, X, Y, Z axis
Operating shock	50(G), 11(ms), half-sine wave
Non-operating shock	1,500(G), 0.5(ms), half-sine wave

4.4 Mean Time Between Failures (MTBF)

Mean Time Between Failures (MTBF) is predicted based on reliability data for the individual components in SDM5A-M. The prediction result for SDM5A-M is more than 1,000,000 hours.

Notes about the MTBF:

The MTBF is predicated and calculated based on “Telcordia Technologies Special Report, SR-332, Issue 2” method.

4.5 Certification and Compliance

SDM5A-M complies with the following standards:

- CE
- FCC
- RoHS Recast
- MIL-STD-810

5. Flash Management

5.1 Error Correction/Detection

SDM5A-M implements a hardware ECC scheme, based on the BCH algorithm. It can detect and correct up to 40 bits error in 1K bytes.

5.2 Bad Block Management

Current production technology is unable to guarantee total reliability of NAND flash memory array. When a flash memory device leaves factory, it comes with a minimal number of initial bad blocks during production or out-of-factory as there is no currently known technology that produce flash chips free of bad blocks. In addition, bad blocks may develop during program/erase cycles. When host performs program/erase command on a block, bad block may appear in Status Register. Since bad blocks are inevitable, the solution is to keep them in control. Apacer flash devices are programmed with ECC, block mapping technique and S.M.A.R.T to reduce invalidity or error. Once bad blocks are detected, data in those blocks will be transferred to free blocks and error will be corrected by designated algorithms.

5.3 Wear Leveling

Flash memory devices differ from Hard Disk Drives (HDDs) in terms of how blocks are utilized. For HDDs, when a change is made to stored data, like erase or update, the controller mechanism on HDDs will perform overwrites on blocks. Unlike HDDs, flash blocks cannot be overwritten and each P/E cycle wears down the lifespan of blocks gradually. Repeatedly program/erase cycles performed on the same memory cells will eventually cause some blocks to age faster than others. This would bring flash storages to their end of service term sooner. Wear leveling is an important mechanism that level out the wearing of blocks so that the wearing-down of blocks can be almost evenly distributed. This will increase the lifespan of SSDs. Commonly used wear leveling types are Static and Dynamic.

5.4 Power Failure Management

Power Failure Management plays a crucial role when experiencing unstable power supply. Power disruption may occur when users are storing data into the SSD. In this urgent situation, the controller would run multiple write-to-flash cycles to store the metadata for later block rebuilding. This urgent operation requires about several milliseconds to get it done. At the next power up, the firmware will perform a status tracking to retrieve the mapping table and resume previously programmed NAND blocks to check if there is any incompleteness of transmission.

5.5 ATA Secure Erase

ATA Secure Erase is an ATA disk purging command currently embedded in most of the storage drives. Defined in ATA specifications, (ATA) Secure Erase is part of Security Feature Set that allows storage drives to erase all user data areas. The erase process usually runs on the firmware level as most of the ATA-based storage media currently in the market are built-in with this command. ATA Secure Erase can securely wipe out the user data in the drive and protects it from malicious attack.

5.6 TRIM

TRIM is a SATA command that helps improve the read/write performance and efficiency of solid-state drives (SSD). The command enables the host operating system to inform SSD controller which blocks contain invalid data, mostly because of the erase commands from host. The invalid will be discarded permanently and the SSD will retain more space for itself.

6. Software Interface

6.1 Command Set

This section defines the software requirements and the format of the commands the host sends to SDM5A-M. Commands are issued to SDM5A-M by loading the required registers in the command block with the supplied parameters, and then writing the command code to the Command register.

Table 6-1: Command Set

Code	Command	Code	Command
E5h	Check Power Mode	F3h	Security Erase Prepare
06h	Data Set Management	F4h	Security Erase Unit
90h	Execute Device Diagnostic	F5h	Security Freeze Lock
E7h	Flush Cache	F1h	Security Set Password
EAh	Flush Cache EXT	F2h	Security Unlock
ECh	Identify Device	70h	Seek
E3h	Idle	EFh	Set Features
E1h	Idle Immediate	C6h	Set Multiple Mode
91h	Initialize Device Parameters	E6h	Sleep
C8h	Read DMA	B0h	SMART
25h	Read DMA EXT	E2h	Standby
C4h	Read Multiple	E0h	Standby Immediate
29h	Read Multiple EXT	CAh	Write DMA
20h	Read Sector	35h	Write DMA EXT
24h	Read Sector EXT	C5h	Write Multiple
40h	Read Verify Sectors	39h	Write Multiple EXT
42h	Read Verify Sectors EXT	30h	Write Sector
10h	Recalibrate	34h	Write Sector EXT
F6h	Security Disable Password		

6.2 S.M.A.R.T.

S.M.A.R.T. is an abbreviation for Self-Monitoring, Analysis and Reporting Technology, a self-monitoring system that provides indicators of drive health as well as potential disk problems. It serves as a warning for users from unscheduled downtime by monitoring and displaying critical drive information. Ideally, this should allow taking proactive actions to prevent drive failure and make use of S.M.A.R.T. information for future product development reference.

Apacer devices use the standard SMART command B0h to read data out from the drive to activate our S.M.A.R.T. feature that complies with the ATA/ATAPI specifications. S.M.A.R.T. Attribute IDs shall include initial bad block count, total later bad block count, maximum erase count, average erase count, power on hours and power cycle. When the S.M.A.R.T. Utility running on the host, it analyzes and reports the disk status to the host before the device reaches in critical condition.

SATA-Disk Module 5A-M APSDMxxxG42AN-CTM1X

Note: attribute IDs may vary from product models due to various solution design and supporting capabilities.

Apacer memory products come with S.M.A.R.T. commands and subcommands for users to obtain information of drive status and to predict potential drive failures. Users can take advantage of the following commands/subcommands to monitor the health of the drive.

Code	SMART Subcommand
D0h	READ DATA
D1h	READ ATTRIBUTE THRESHOLDS
D2h	Enable/Disable Attribute Autosave
D4h	Execute Off-line Immediate
D5h	Read Log (optional)
D6h	Write Log (optional)
D8h	Enable Operations
D9h	Disable operations
DAh	Return Status

General SMART attribute structure

Byte	Description
0	ID (Hex)
1 – 2	Status flag
3	Value
4	Worst
5*-11	Raw Data

*Byte 5: LSB

SMART attribute ID list

ID (Hex)	Attribute Name
9 (0x09)	Power-on hours
12 (0x0C)	Power cycle count
163 (0xA3)	Max. erase count
164 (0xA4)	Avg. erase count
166 (0xA6)	Total later bad block count
167 (0xA7)	SSD Protect Mode (vendor specific)
168 (0xA8)	SATA PHY Error Count
175 (0xAF)	Bad Cluster Table Count
192 (0xC0)	Unexpected Power Loss Count
194 (0xC2)	Temperature
241 (0xF1)	Total sectors of write

7. Electrical Specifications

Caution: Absolute Maximum Stress Ratings – Applied conditions greater than those listed under “Absolute Maximum Stress Ratings” may cause permanent damage to the device. This is a stress rating only and functional operation of the device at these conditions or conditions greater than those defined in the operational sections of this data sheet is not implied. Exposure to absolute maximum stress rating conditions may affect device reliability.

Table 7-1: Operating Range

Supply Voltage	5V ± 5% (4.75-5.25V)
-----------------------	----------------------

Table 7-2: Typical Power Consumption

Capacity	8 GB	16 GB	32 GB	64 GB
Modes				
Active (mA)	155	175	175	205
Idle (mA)	80	80	80	80

Note: Results may differ from various flash configurations or host system setting.

8. Physical Characteristics

8.1 Dimensions



Unit: mm
Tolerance: ± 0.25

9. Product Ordering Information

9.1 Product Code Designations

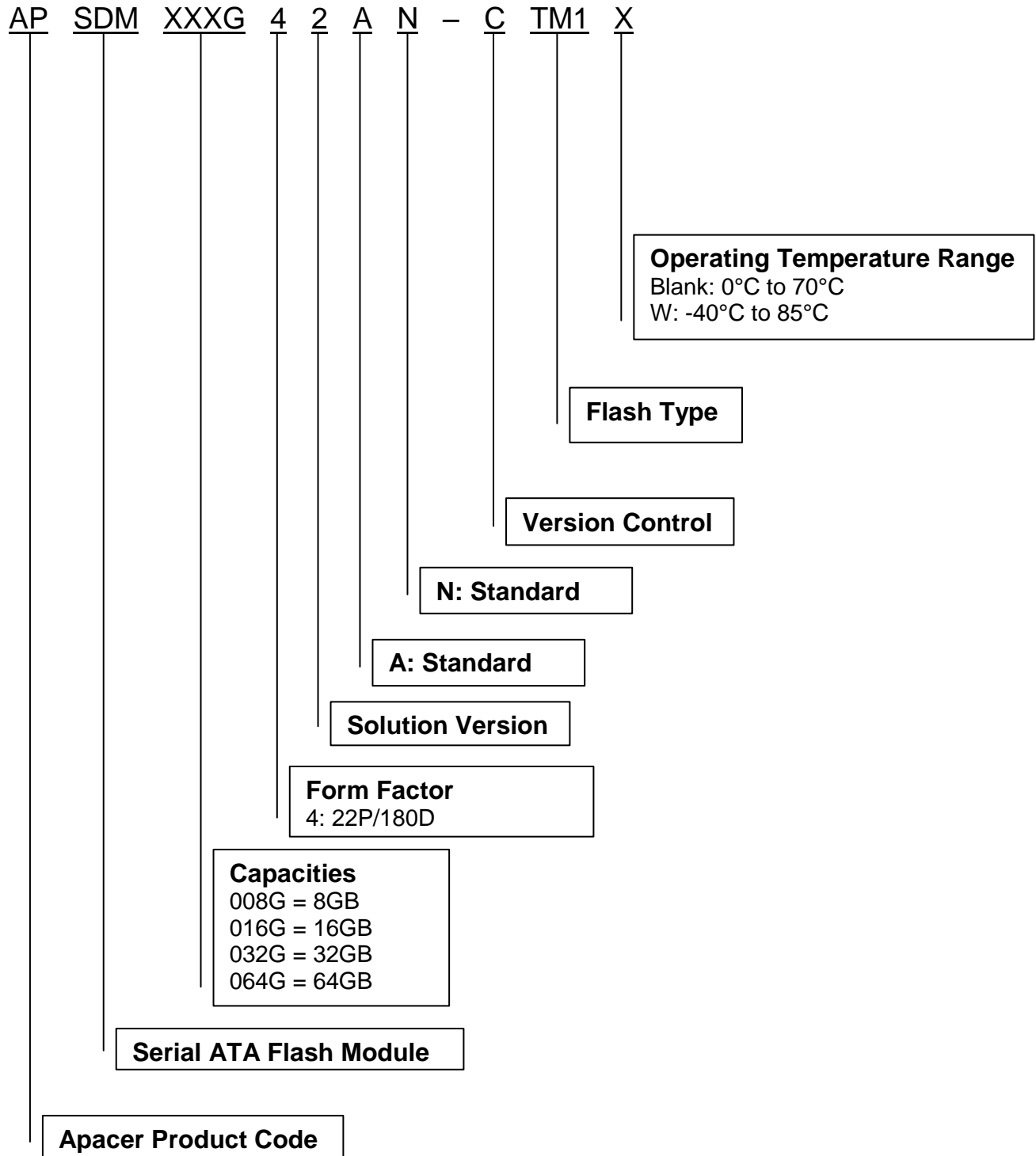

9.2 Valid Combinations

Capacity	Standard	Extended Temperature
8GB	APSDM008G42AN-CTM1	APSDM008G42AN-CTM1W
16GB	APSDM016G42AN-CTM1	APSDM016G42AN-CTM1W
32GB	APSDM032G42AN-CTM1	APSDM032G42AN-CTM1W
64GB	APSDM064G42AN-CTM1	APSDM064G42AN-CTM1W

Note: Valid combinations are those products in mass production or will be in mass production. Consult your Apacer sales representative to confirm availability of valid combinations and to determine availability of new combinations.

Revision History

Revision	Date	Description	Remark
1.0	1/7/2016	Official release	

Global Presence

Taiwan (Headquarters)	Apacer Technology Inc. Apacer Technology Inc. 1F., No.32, Zhongcheng Rd., Tucheng Dist., New Taipei City 236, Taiwan R.O.C. Tel: 886-2-2267-8000 Fax: 886-2-2267-2261 amtsales@apacer.com
U.S.A.	Apacer Memory America, Inc. 46732 Lakeview Blvd., Fremont, CA 94538 Tel: 1-408-518-8699 Fax: 1-510-249-9568 sa@apacerus.com
Japan	Apacer Technology Corp. 5F, Matsura Bldg., Shiba, Minato-Ku Tokyo, 105-0014, Japan Tel: 81-3-5419-2668 Fax: 81-3-5419-0018 jpservices@apacer.com
Europe	Apacer Technology B.V. Science Park Eindhoven 5051 5692 EB Son, The Netherlands Tel: 31-40-267-0000 Fax: 31-40-267-0000#6199 sales@apacer.nl
China	Apacer Electronic (Shanghai) Co., Ltd Room D, 22/FL, No.2, Lane 600, JieyunPlaza, Tianshan RD, Shanghai, 200051, China Tel: 86-21-6228-9939 Fax: 86-21-6228-9936 sales@apacer.com.cn
India	Apacer Technologies Pvt Ltd, Unit No.201, "Brigade Corner", 7 th Block Jayanagar, Yediyur Circle, Bangalore – 560082, India Tel: 91-80-4152-9061 Fax: 91-80-4170-0215 sales_india@apacer.com



Компания «ЭлектроПласт» предлагает заключение долгосрочных отношений при поставках импортных электронных компонентов на взаимовыгодных условиях!

Наши преимущества:

- Оперативные поставки широкого спектра электронных компонентов отечественного и импортного производства напрямую от производителей и с крупнейших мировых складов;
- Поставка более 17-ти миллионов наименований электронных компонентов;
- Поставка сложных, дефицитных, либо снятых с производства позиций;
- Оперативные сроки поставки под заказ (от 5 рабочих дней);
- Экспресс доставка в любую точку России;
- Техническая поддержка проекта, помощь в подборе аналогов, поставка прототипов;
- Система менеджмента качества сертифицирована по Международному стандарту ISO 9001;
- Лицензия ФСБ на осуществление работ с использованием сведений, составляющих государственную тайну;
- Поставка специализированных компонентов (Xilinx, Altera, Analog Devices, Intersil, Interpoint, Microsemi, Aeroflex, Peregrine, Syfer, Eurofarad, Texas Instrument, Miteq, Cobham, E2V, MA-COM, Hittite, Mini-Circuits, General Dynamics и др.);

Помимо этого, одним из направлений компании «ЭлектроПласт» является направление «Источники питания». Мы предлагаем Вам помощь Конструкторского отдела:

- Подбор оптимального решения, техническое обоснование при выборе компонента;
- Подбор аналогов;
- Консультации по применению компонента;
- Поставка образцов и прототипов;
- Техническая поддержка проекта;
- Защита от снятия компонента с производства.



Как с нами связаться

Телефон: 8 (812) 309 58 32 (многоканальный)

Факс: 8 (812) 320-02-42

Электронная почта: org@eplast1.ru

Адрес: 198099, г. Санкт-Петербург, ул. Калинина, дом 2, корпус 4, литера А.