

19-OUTPUT PCIe GEN 3 BUFFER

Features

- Nineteen 0.7 V current-mode, HCSL PCIe Gen 3 outputs
- 100 MHz /133 MHz PLL operation, supports PCIe and QPI
- PLL bandwidth SW SMBUS programming overrides the latch value from HW pin
- 9 selectable SMBus addresses
- Fixed external feedback path
- 8 dedicated OE pin
- PLL or bypass mode
- Spread spectrum tolerable
- 50 ps output-to-output skew
- Fixed 0 ps input to output delay
- Low phase jitter (Intel QPI, PCIe Gen 1/Gen 2/Gen 3/Gen 4 common clock compliant)
- Gen 3 SRNS Compliant
- 100 ps input-to-output delay
- Extended Temperature: -40 to 85 °C
- Package: 72-pin QFN

Applications

- Server
- Storage
- Data Center
- Network Security

Description

The Si53019-A01A is a 19-output, current mode HCSL differential clock buffer that meets all of the performance requirements of the Intel DB1900Z specification. The device is optimized for distributing reference clocks for Intel® QuickPath Interconnect (Intel QPI), PCIe Gen 1/Gen 2/Gen 3/Gen 4, SAS, SATA, and Intel Scalable Memory Interconnect (Intel SMI) applications. The VCO of the device is optimized to support 100 MHz and 133 MHz operation. Each differential output can be enabled through I²C for maximum flexibility and power savings. Measuring PCIe clock jitter is quick and easy with the Silicon Labs PCIe Clock Jitter Tool. Download it for free at www.silabs.com/pcie-learningcenter.

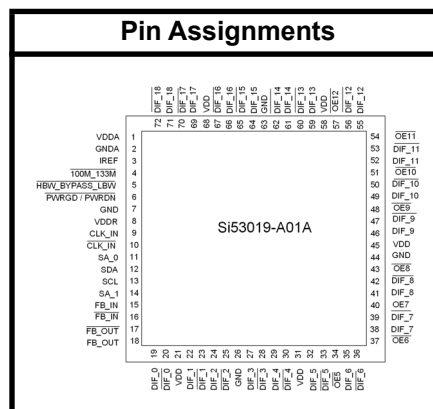
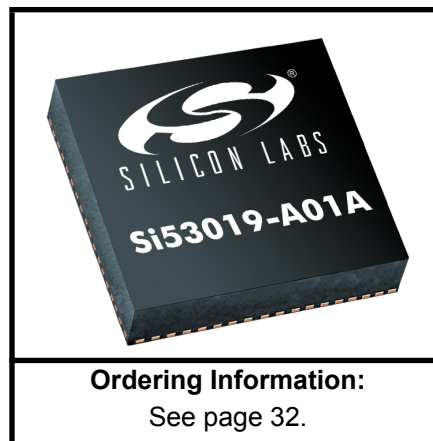

Patents pending

Si53019-A01A

Functional Block Diagram

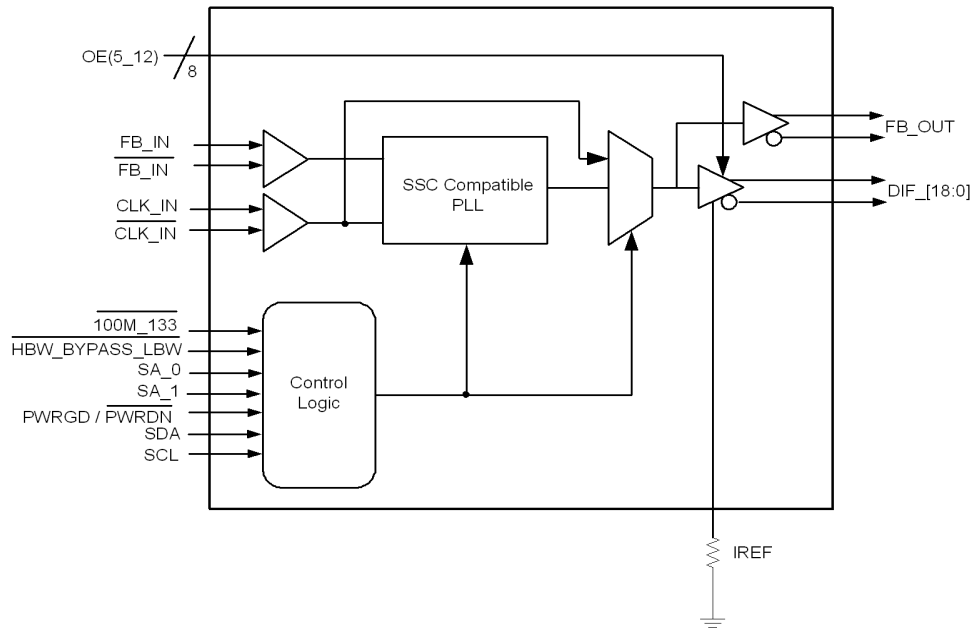

TABLE OF CONTENTS

<u>Section</u>	<u>Page</u>
1. Electrical Specifications	4
2. Functional Description	13
2.1. CLK_IN, CLK_IN	15
2.2. 100M_133M—Frequency Selection	15
2.3. SA_0, SA_1—Address Selection	15
2.4. CKPWRGD/PWRDN	16
2.5. HBW_BYPASS_LBW	18
2.6. Miscellaneous Requirements	18
3. Test and Measurement Setup	19
3.1. Input Edge	19
3.2. Termination of Differential Outputs	20
4. Control Registers	21
4.1. Byte Read/Write	21
4.2. Block Read/Write	22
4.3. Control Registers	23
5. Pin Descriptions: 72-Pin QFN	27
6. Power Filtering Example	31
6.1. Ferrite Bead Power Filtering	31
7. Ordering Guide	32
8. Package Outline	33
9. PCB Land Pattern	34
9.1. 10x10 mm 72-QFN Package Land Pattern	34
Document Change List	36

Si53019-A01A

1. Electrical Specifications

Table 1. DC Operating Characteristics¹

$V_{DD_A} = 3.3\text{ V} \pm 5\%$, $V_{DD} = 3.3\text{ V} \pm 5\%$

Parameter	Symbol	Test Condition	Min	Max	Unit
3.3 V Core Supply Voltage	VDD/VDD_A	3.3 V $\pm 5\%$	3.135	3.465	V
3.3 V Input High Voltage	V _{IH}	V _{DD}	2.0	V _{DD} +0.3	V
3.3 V Input Low Voltage	V _{IL}		VSS-0.3	0.8	V
Input Leakage Current ²	I _{IL}	0 < V _{IN} < V _{DD}	-5	+5	μA
3.3 V Input High Voltage ³	V _{IH_FS}	V _{DD}	0.7	V _{DD} +0.3	V
3.3 V Input Low Voltage ³	V _{IL_FS}		VSS-0.3	0.35	V
3.3 V Input Low Voltage	V _{IL_Tri}		0	0.9	V
3.3 V Input Med Voltage	V _{IM_Tri}		1.3	1.8	V
3.3 V Input High Voltage	V _{IH_Tri}		2.4	V _{DD}	V
3.3 V Output High Voltage ⁴	V _{OH}	I _{OH} = -1 mA	2.4	—	V
3.3 V Output Low Voltage ⁴	V _{OL}	I _{OL} = 1 mA	—	0.4	V
Input Capacitance ⁵	C _{IN}		2.5	4.5	pF
Output Capacitance ⁵	C _{OUT}		2.5	4.5	pF
Pin Inductance	L _{PIN}		—	7	nH
Ambient Temperature	T _A	No Airflow	-40	85	$^{\circ}\text{C}$

Notes:

1. VDD_IO applies to the low-power NMOS push-pull HCSL compatible outputs.
2. Input Leakage Current does not include inputs with pull-up or pull-down resistors. Inputs with resistors should state current requirements.
3. Internal voltage reference is to be used to guarantee V_{IH_FS} and V_{IL_FS} thresholds levels over full operating range.
4. Signal edge is required to be monotonic when transitioning through this region.
5. Ccomp capacitance based on pad metallization and silicon device capacitance. Not including pin capacitance.

Table 2. DIF 0.7 V AC Timing Characteristics (Non-Spread Spectrum Mode)¹

Parameter	Symbol	CLK 100 MHz, 133 MHz			Unit
		Min	Typ	Max	
Clock Stabilization Time ²	T _{STAB}	—	1.5	1.8	ms
Long Term Accuracy ^{3,4,5}	L _{ACC}	—	—	100	ppm
Absolute Host CLK Period (100 MHz) ^{3,4,6}	T _{ABS}	9.94900	—	10.05100	ns
Absolute Host CLK Period (133 MHz) ^{3,4,6}	T _{ABS}	7.44925	—	7.55075	ns
Slew Rate ^{3,4,7}	Edge_rate	1.0	3.0	4.0	V/ns
Slew Rate Matching ^{3,8,10,11}	T _{RISE_MAT} / T _{FALL_MAT}	—	7	20	%
Rise Time Variation ^{3,8,9}	Δ Trise	—	—	125	ps
Fall Time Variation ^{3,8,9}	Δ Tfall	—	—	125	ps
Voltage High (typ 0.7 V) ^{3,8,12}	V _{HIGH}	660	750	850	mV
Voltage Low (typ 0.7 V) ^{3,8,13}	V _{LOW}	-150	15	150	mV

Notes:

1. Unless otherwise noted, all specifications in this table apply to all processor frequencies.
2. This is the time from the valid CLK_IN input clocks and the assertion of the PWRGD signal level at 1.8–2.0 V to the time that stable clocks are output from the buffer chip (PLL locked).
3. Test configuration is Rs = 33.2 Ω, Rp = 49.9, 2 pF for 100 Ω transmission line; Rs = 27 Ω, Rp = 42.2, 2 pF for 85 Ω transmission line.
4. Measurement taken from differential waveform.
5. Using frequency counter with the measurement interval equal or greater than 0.15 s, target frequencies are 99,750,00 Hz, 133,000,000 Hz.
6. The average period over any 1 μs period of time must be greater than the minimum and less than the maximum specified period.
7. Measure taken from differential waveform on a component test board. The edge (slew) rate is measured from -150 mV to +150 mV on the differential waveform. Scope is set to average because the scope sample clock is making most of the dynamic wiggles along the clock edge Only valid for Rising CLOCK and Falling CLOCK. Signal must be monotonic through the Vol to Voh region for Trise and Tfall.
8. Measurement taken from single-ended waveform.
9. Measured with oscilloscope, averaging off, using min max statistics. Variation is the delta between min and max.
10. Measured with oscilloscope, averaging on, The difference between the rising edge rate (average) of clock verses the falling edge rate (average) of CLOCK.
11. Rise/Fall matching is derived using the following, 2*(Trise - Tfall) / (Trise + Tfall).
12. VHigh is defined as the statistical average High value as obtained by using the Oscilloscope VHigh Math function.
13. VLow is defined as the statistical average Low value as obtained by using the Oscilloscope VLow Math function.
14. Measured at crossing point where the instantaneous voltage value of the rising edge of CLK equals the falling edge of CLK.
15. This measurement refers to the total variation from the lowest crossing point to the highest, regardless of which edge is crossing.
16. The crossing point must meet the absolute and relative crossing point specifications simultaneously.
17. Vcross(rel) Min and Max are derived using the following, Vcross(rel) Min = 0.250 + 0.5 (Vhavg - 0.700), Vcross(rel) Max = 0.550 - 0.5 (0.700 - Vhavg), (see Figure 4–5 for further clarification).
18. ΔVcross is defined as the total variation of all crossing voltages of Rising CLOCK and Falling CLOCK. This is the maximum allowed variance in Vcross for any particular system.
19. Overshoot is defined as the absolute value of the maximum voltage.
20. Undershoot is defined as the absolute value of the minimum voltage.

Table 2. DIF 0.7 V AC Timing Characteristics (Non-Spread Spectrum Mode)¹ (Continued)

Parameter	Symbol	CLK 100 MHz, 133 MHz			Unit
		Min	Typ	Max	
Maximum Voltage ⁸	V _{MAX}	—	850	1150	mV
Minimum Voltage ^{3,8,14,15,16}	V _{MIN}	-300	—	—	mV
Absolute Crossing Point Voltages	V _{OXABS}	250	450	550	mV
Total Variation of Vcross Over All Edges ^{3,8,18}	Total Δ Vox	—	14	140	mV
Vswing ⁴	Vswing	300	—	—	mV
Duty Cycle ^{3,4}	DC	45	—	55	%
Maximum Voltage (Overshoot) ^{3,8,19}	V _{ovs}	—	—	V _{High} + 0.3	V
Maximum Voltage (Undershoot) ^{3,8,20}	V _{uds}	—	—	V _{Low} - 0.3	V
Ringback Voltage ^{3,8}	V _{rb}	0.2	—	N/A	V

Notes:

1. Unless otherwise noted, all specifications in this table apply to all processor frequencies.
2. This is the time from the valid CLK_IN input clocks and the assertion of the PWRGD signal level at 1.8–2.0 V to the time that stable clocks are output from the buffer chip (PLL locked).
3. Test configuration is R_s = 33.2 Ω, R_p = 49.9, 2 pF for 100 Ω transmission line; R_s = 27 Ω, R_p = 42.2, 2 pF for 85 Ω transmission line.
4. Measurement taken from differential waveform.
5. Using frequency counter with the measurement interval equal or greater than 0.15 s, target frequencies are 99,750,00 Hz, 133,000,000 Hz.
6. The average period over any 1 μs period of time must be greater than the minimum and less than the maximum specified period.
7. Measure taken from differential waveform on a component test board. The edge (slew) rate is measured from -150 mV to +150 mV on the differential waveform. Scope is set to average because the scope sample clock is making most of the dynamic wiggles along the clock edge Only valid for Rising CLOCK and Falling CLOCK. Signal must be monotonic through the Vol to Voh region for Trise and Tfall.
8. Measurement taken from single-ended waveform.
9. Measured with oscilloscope, averaging off, using min max statistics. Variation is the delta between min and max.
10. Measured with oscilloscope, averaging on, The difference between the rising edge rate (average) of clock verses the falling edge rate (average) of CLOCK.
11. Rise/Fall matching is derived using the following, 2*(Trise - Tfall) / (Trise + Tfall).
12. VHigh is defined as the statistical average High value as obtained by using the Oscilloscope VHigh Math function.
13. VLow is defined as the statistical average Low value as obtained by using the Oscilloscope VLow Math function.
14. Measured at crossing point where the instantaneous voltage value of the rising edge of CLK equals the falling edge of CLK.
15. This measurement refers to the total variation from the lowest crossing point to the highest, regardless of which edge is crossing.
16. The crossing point must meet the absolute and relative crossing point specifications simultaneously.
17. Vcross(rel) Min and Max are derived using the following, Vcross(rel) Min = 0.250 + 0.5 (Vhavg - 0.700), Vcross(rel) Max = 0.550 - 0.5 (0.700 - Vhavg), (see Figure 4–5 for further clarification).
18. ΔVcross is defined as the total variation of all crossing voltages of Rising CLOCK and Falling CLOCK. This is the maximum allowed variance in Vcross for any particular system.
19. Overshoot is defined as the absolute value of the maximum voltage.
20. Undershoot is defined as the absolute value of the minimum voltage.

Table 3. SMBus Characteristics

Parameter	Symbol	Test Condition	Min	Max	Unit
SMBus Input Low Voltage ¹	V_{ILSMB}		—	0.8	V
SMBus Input High Voltage ¹	V_{IHSMB}		2.1	V_{DDSMB}	V
SMBus Output Low Voltage ¹	V_{OLSMB}	@ I_{PULLUP}	—	0.4	V
Nominal Bus Voltage ¹	V_{DDSMB}	@ V_{OL}	2.7	5.5	V
SMBus sink Current ¹	I_{PULLUP}	3 V to 5 V +/-10%	4	—	mA
SCLK/SDAT Rise Time ¹	t_{RSMB}	(Max $V_{IL} - 0.15$) to (Min $V_{IH} + 0.15$)	—	1000	ns
SCLK/SDAT Fall Time ¹	t_{FSMB}	(Min $V_{IH} + 0.15$) to (Max $V_{IL} - 0.15$)	—	300	ns
SMBus Operating Frequency ^{1,2}	f_{MINSMB}	Minimum Operating Frequency	—	100	kHz

Notes:

- Guaranteed by design and characterization.
- The differential input clock must be running for the SMBus to be active.

Table 4. Current Consumption

$T_A = -40-85\text{ }^\circ\text{C}$; supply voltage $V_{DD} = 3.3\text{ V} \pm 5\%$

Parameter	Symbol	Test Condition	Min	Typ	Max	Unit
Operating Current	IDD_{VDD}	100 MHz, CL = Full Load, $R_s=33\ \Omega$	—	310	350	mA
Power Down Current	IDD_{VDDPD}	All differential pairs tri-stated	—	6	15	mA

Si53019-A01A

Table 5. Clock Input Parameters

$T_A = -40-85\text{ }^\circ\text{C}$; supply voltage $V_{DD} = 3.3\text{ V} \pm 5\%$

Parameter	Symbol	Test Condition	Min	Typ	Max	Unit
Input High Voltage	V_{IHDIF}	Differential Inputs (singled-ended measurement)	600	800	1150	mV
Input Low Voltage	V_{IHDIF}	Differential Inputs (singled-ended measurement)	$V_{SS}-300$	0	300	mV
Input Common Mode Voltage	V_{com}	Common mode input voltage	300	—	1000	mV
Input Amplitude	V_{swing}	Peak to Peak Value	300	—	1900	mV
Input Slew Rate	dv/dt	Measured differentially	0.4	—	8	V/ns
Input Duty Cycle		Measurement from differential wave form	45	50	55	%
Input Jitter—Cycle to Cycle	J_{DFin}	Differential measurement	—	—	125	ps
Input Frequency	F_{ibyp}	$V_{DD} = 3.3\text{ V}$, bypass mode	33	—	150	MHz
	F_{iPLL}	$V_{DD} = 3.3\text{ V}$, 100 MHz PLL Mode	90	100	110	MHz
	F_{iPLL}	$V_{DD} = 3.3\text{ V}$, 133.33 MHz PLL Mode	120	133.33	147	MHz
Input SS Modulation Rate	f_{MODIN}	Triangle Wave modulation	30	31.5	33	kHz

Table 6. Output Skew, PLL Bandwidth and PeakingT_A = -40–85 °C; supply voltage V_{DD} = 3.3 V ±5%

Parameter	Test Condition	Min	TYP	Max	Unit
CLK_IN, DIF[x:0]	Input-to-Output Delay in PLL Mode Nominal Value ^{1,2,3,4}	-100	20	100	ps
CLK_IN, DIF[x:0]	Input-to-Output Delay in Bypass Mode Nominal Value ^{2,4,5}	2.5	3.4	4.5	ns
CLK_IN, DIF[x:0]	Input-to-Output Delay Variation in PLL Mode Over voltage and temperature ^{2,4,5}	-50	0	50	ps
CLK_IN, DIF[x:0]	Input-to-Output Delay Variation in Bypass Mode Over voltage and temperature ^{2,4,5}	-250	—	250	ps
CLK_IN, DIF[x:0]	Random differential spread spectrum tracking error between 2 DB1900Z devices in Hi BW Mode	—	15	75	ps
CLK_IN, DIF[x:0]	Random differential tracking error between 2 DB1900Z devices in Hi BW Mode	—	3	5	ps (rms)
DIF[18:0]	Output-to-Output Skew across all Outputs (Common to Bypass and PLL Mode) ^{1,2,3,4,5}	0	20	50	ps
PLL Jitter Peaking	(HBW_BYPASS_LBW = 0) ⁶	—	0.4	2.0	dB
PLL Jitter Peaking	(HBW_BYPASS_LBW = 1) ⁶	—	0.1	2.5	dB
PLL Bandwidth	(HBW_BYPASS_LBW = 0) ⁷	—	0.7	1.4	MHz
PLL Bandwidth	(HBW_BYPASS_LBW = 1) ⁷	—	2	4	MHz

Notes:

1. Measured into fixed 2 pF load cap. Input-to-output skew is measured at the first output edge following the corresponding input.
2. Measured from differential cross-point to differential cross-point.
3. This parameter is deterministic for a given device.
4. Measured with scope averaging on to find mean value.
5. All Bypass Mode Input-to-Output specs refer to the timing between an input edge and the specific output edge created by it.
6. Measured as maximum pass band gain. At frequencies within the loop BW, highest point of magnification is called PLL jitter peaking.
7. Measured at 3 db down or half power point.

Table 7. Phase Jitter

Parameter	Test Condition	Min	Typ	Max	Unit
Phase Jitter PLL Mode	PCIe Gen 1, Common Clock ^{1,2,3}	—	30	86	ps
	PCIe Gen 2 Low Band, Common Clock F < 1.5 MHz ^{1,3,4,5}	—	1.0	3.0	ps (RMS)
	PCIe Gen2 High Band, Common Clock 1.5 MHz < F < Nyquist ^{1,3,4,5}	—	2.6	3.1	ps (RMS)
	PCIe Gen 3, Common Clock (PLL BW 2–4 MHz, CDR = 10 MHz) ^{1,3,4,5}	—	0.6	1.0	ps (RMS)
	PCIe Gen 3 Separate Reference No Spread, SRNS (PLL BW of 2–4 or 2–5 MHz, CDR = 10 MHz) ^{1,3,4,5}	—	0.42	0.71	ps (RMS)
	PCIe Gen 4, Common Clock (PLL BW of 2–4 or 2–5 MHz, CDR = 10 MHz) ^{1,4,5,8}	—	0.6	1.0	ps (RMS)
	Intel® QPI & Intel SMI (4.8 Gbps or 6.4 Gb/s, 100 or 133 MHz, 12 UI) ^{1,6,7}	—	0.25	0.5	ps (RMS)
	Intel QPI & Intel SMI (8 Gb/s, 100 MHz, 12 UI) ^{1,6}	—	0.17	0.3	ps (RMS)
	Intel QPI & Intel SMI (9.6 Gb/s, 100 MHz, 12 UI) ^{1,6}	—	0.15	0.2	ps (RMS)

Notes:

1. Post processed evaluation through Intel supplied Matlab* scripts. Defined for a BER of 1E-12. Measured values at a smaller sample size have to be extrapolated to this BER target.
2. $\zeta = 0.54$ implies a jitter peaking of 3 dB.
3. PCIe* Gen3 filter characteristics are subject to final ratification by PCISIG. Check the PCI-SIG for the latest specification.
4. Measured on 100 MHz PCIe output using the template file in the Intel-supplied Clock Jitter Tool V1.6.3.
5. Measured on 100 MHz output using the template file in the Intel-supplied Clock Jitter Tool V1.6.3.
6. Measured on 100 MHz, 133 MHz output using the template file in the Intel-supplied Clock Jitter Tool V1.6.3.
7. These jitter numbers are defined for a BER of 1E-12. Measured numbers at a smaller sample size have to be extrapolated to this BER target.
8. Gen 4 specifications based on the PCI-Express Base Specification 4.0 rev. 0.5.
9. Download the Silicon Labs PCIe Clock Jitter Tool at www.silabs.com/pcie-learningcenter.

Table 7. Phase Jitter (Continued)

Additive Phase Jitter Bypass Mode	PCIe Gen 1 ^{1,2,3}	—	4	—	ps
	PCIe Gen 2 Low Band F < 1.5 MHz ^{1,3,4,5}	—	0.08	—	ps (RMS)
	PCIe Gen 2 High Band 1.5 MHz < F < Nyquist ^{1,3,4,5}	—	1	—	ps (RMS)
	PCIe Gen 3 (PLL BW 2–4 MHz, CDR = 10 MHz) ^{1,3,4,5}	—	0.27	—	ps (RMS)
	PCIe Gen 4, Common Clock (PLL BW of 2–4 or 2–5 MHz, CDR = 10 MHz) ^{1,4,5,8}	—	0.27	—	ps (RMS)
	Intel QPI & Intel® SMI (4.8 Gbps or 6.4 Gb/s, 100 or 133 MHz, 12 UI) ^{1,6,7}	—	0.25	—	ps (RMS)
	Intel QPI & Intel® SMI (8 Gb/s, 100 MHz, 12 UI) ^{1,6}	—	0.08	—	ps (RMS)
	Intel QPI & Intel® SMI (9.6 Gb/s, 100 MHz, 12 UI) ^{1,6}	—	0.07	—	ps (RMS)

Notes:

1. Post processed evaluation through Intel supplied Matlab* scripts. Defined for a BER of 1E-12. Measured values at a smaller sample size have to be extrapolated to this BER target.
2. $\zeta = 0.54$ implies a jitter peaking of 3 dB.
3. PCIe* Gen3 filter characteristics are subject to final ratification by PCISIG. Check the PCI-SIG for the latest specification.
4. Measured on 100 MHz PCIe output using the template file in the Intel-supplied Clock Jitter Tool V1.6.3.
5. Measured on 100 MHz output using the template file in the Intel-supplied Clock Jitter Tool V1.6.3.
6. Measured on 100 MHz, 133 MHz output using the template file in the Intel-supplied Clock Jitter Tool V1.6.3.
7. These jitter numbers are defined for a BER of 1E-12. Measured numbers at a smaller sample size have to be extrapolated to this BER target.
8. Gen 4 specifications based on the PCI-Express Base Specification 4.0 rev. 0.5.
9. Download the Silicon Labs PCIe Clock Jitter Tool at www.silabs.com/pcie-learningcenter.

Table 8. Clock Periods Differential Clock Outputs with SSC Disabled

SSC OFF Center Freq, MHz	Measurement Window							Unit
	1 Clock	1 μ s	0.1 s	0.1 s	0.1 s	1 μ s	1 Clock	
	-C-C Jitter AbsPer Min	-SSC Short Term AVG Min	-ppm Long Term AVG Min	0 ppm Period Nominal	+ppm Long Term AVG Max	+SSC Short Term AVG Max	+C-C Jitter AbsPer Max	
100.00	9.94900		9.99900	10.00000	10.00100		10.05100	ns
133.33	7.44925		7.49925	7.50000	7.50075		7.55075	ns

Table 9. Clock Periods Differential Clock Outputs with SSC Enabled

SSC ON Center Freq, MHz	Measurement Window							Unit
	1 Clock	1 μ s	0.1 s	0.1 s	0.1 s	1 μ s	1 Clock	
	-C-C Jitter AbsPer Min	-SSC Short Term AVG Min	-ppm Long Term AVG Min	0 ppm Period Nominal	+ppm Long Term AVG Max	+SSC Short Term AVG Max	+C-C Jitter AbsPer Max	
99.75	9.94906	9.99906	10.02406	10.02506	10.02607	10.05107	10.10107	ns
133.00	7.44930	7.49930	7.51805	7.51880	7.51955	7.53830	7.58830	ns

Table 10. Absolute Maximum Ratings

Parameter	Symbol	Min	Max	Unit
3.3 V Core Supply Voltage ¹	VDD/VDD_A	—	4.6	V
3.3 V Input High Voltage ^{1,2}	VIH	—	V _{DD} +0.5 V	V
3.3 V Input Low Voltage ¹	VIL	-0.5	—	V
Storage Temperature ¹	t _s	-65	150	°C
Input ESD protection ³	ESD	2000	—	V

Notes:

1. Consult manufacturer regarding extended operation in excess of normal dc operating parameters.
2. Maximum VIH is not to exceed maximum V_{DD}.
3. Human body model.

2. Functional Description

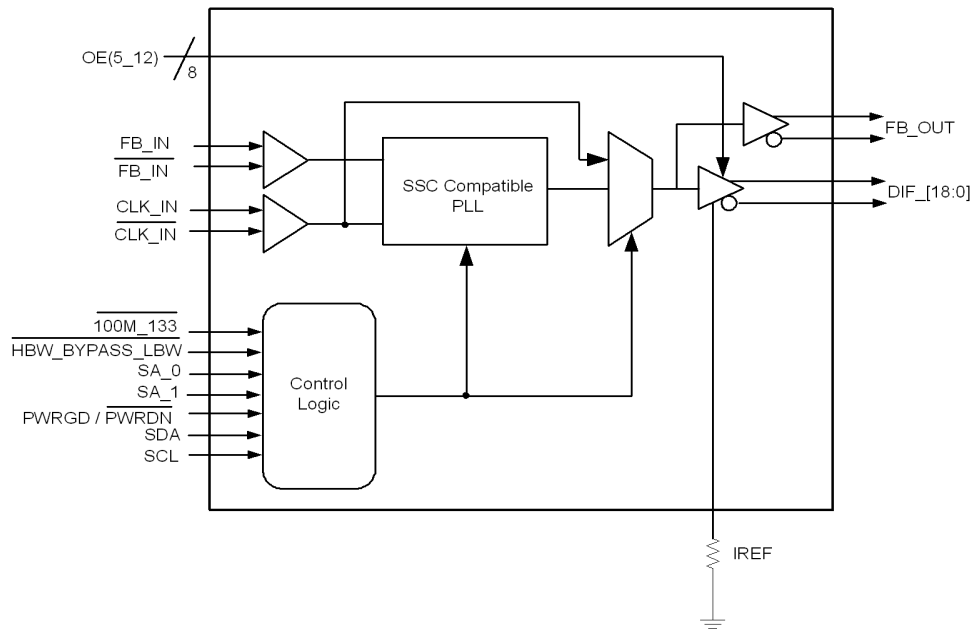

Figure 1. Si53019-A01A Functional Block Diagram

Table 11. Functionality at Power Up (PLL Mode)

100M_133M	CLK_IN (MHz)	Conditions
1	100	CLK_IN
0	133.33	CLK_IN

Table 12. PLL Operating Mode Readback Table

HBW_BYPASS_LBW	Byte 0, Bit 7	Byte 0, Bit 6	Mode
Low	0	0	PLL Low BW
Mid (Bypass)	0	1	Bypass
High	1	1	PLL High BW

Table 13. Tri-Level Input Thresholds

Parameter	Voltage
Low	<0.8 V
Mid	1.2<Vin<1.8 V
High	Vin>2.2 V

Table 14. Power Connections

Pin Number		Description
V _{DD}	GND	
1	2	Analog PLL
8	7	Analog Input
21,31,45,58,68	26,44,63	DIF Outputs

Note: T_A = -40–85 °C; supply voltage V_{DD} = 3.3 V ±5%

Table 15. SMBus Addressing

Pin		SMBus Address
SMB_A1	SMB_A0	
0	0	D8
0	M	DA
0	1	DE
M	0	C2
M	M	C4
M	1	C6
1	0	CA
1	M	CC
1	1	CE

2.1. CLK_IN, $\overline{\text{CLK_IN}}$

The differential input clock is expected to be sourced from a clock synthesizer or PCH.

2.2. $\overline{100M_133M}$ —Frequency Selection

The Si53019-A01A is optimized for lowest phase jitter performance at operating frequencies of 100 and 133 MHz. $\overline{100M_133M}$ is a hardware input pin, which programs the appropriate output frequency of the differential outputs. Note that the CLK_IN frequency must be equal to the CLK_OUT frequency, meaning Si53019-A01A is operated in 1:1 mode only. Frequency selection can be enabled by the $\overline{100M_133M}$ hardware pin. An external pull-up or pull-down resistor is attached to this pin to select the input/output frequency. The functionality is summarized in Table 16.

Table 16. Frequency Program Table

$\overline{100M_133M}$	Optimized Frequency (DIF_IN = DIF_x)
0	133.33 MHz
1	100.00 MHz

Note: All differential outputs transition from 100 to 133 MHz or from 133 to 100 MHz in a glitch free manner.

2.3. SA_0, SA_1—Address Selection

SA_0 and SA_1 are tri-level hardware pins, which program the appropriate address for the Si53019-A01A. The two tri-level input pins can configure the device to nine different addresses.

Table 17. SMBus Address Table

SA_1	SA_0	SMBus Address
L	L	D8
L	M	DA
L	H	DE
M	L	C2
M	M	C4
M	H	C6
H	L	CA
H	M	CC
H	H	CE

2.4. CKPWRGD/ $\overline{\text{PWRDN}}$

CKPWRGD is asserted high and deasserted low. Deassertion of PWRGD (pulling the signal low) is equivalent to indicating a power-down condition. CKPWRGD (assertion) is used by the Si53019-A01A to sample initial configurations, such as frequency select condition and SA selections. After CKPWRGD has been asserted high for the first time, the pin becomes a $\overline{\text{PWRDN}}$ (Power Down) pin that can be used to shut off all clocks cleanly and instruct the device to invoke power-saving mode. $\overline{\text{PWRDN}}$ is a completely asynchronous active low input. When entering power-saving mode, $\overline{\text{PWRDN}}$ should be asserted low prior to shutting off the input clock or power to ensure all clocks shut down in a glitch free manner. When $\overline{\text{PWRDN}}$ is asserted low, all clocks will be disabled prior to turning off the VCO. When $\overline{\text{PWRDN}}$ is deasserted high, all clocks will start and stop without any abnormal behavior and will meet all AC and DC parameters.

Note: The assertion and deassertion of $\overline{\text{PWRDN}}$ is absolutely asynchronous.

Warning: Disabling of the CLK_IN input clock prior to assertion of $\overline{\text{PWRDN}}$ is an undefined mode and not recommended. Operation in this mode may result in glitches, excessive frequency shifting, etc.

Table 18. CKPWRGD/ $\overline{\text{PWRDN}}$ Functionality

CKPWRGD/ $\overline{\text{PWRDN}}$	DIF_IN/ DINF_IN#	SMBus EN bit	OE# Pin	DIF(5:12) DIF(5:12)#	Other DIF/ DIF#	FBOUT_NC/ FBOUT_NC#	PLL State
0	X	X	X	Hi-Z*	Hi-Z*	Hi-Z*	OFF
1	Running	0	X	Hi-Z*	Hi-Z*	Running	ON
		1	0	Running	Running	Running	ON
		1	1	Hi-Z*	Running	Running	ON

***Note:** Due to external pull down resistors, Hi-Z results in Low/Low on the True/Complement outputs.

2.4.1. $\overline{\text{PWRDN}}$ Assertion

When $\overline{\text{PWRDN}}$ is sampled low by two consecutive rising edges of $\overline{\text{DIF}}$, all differential outputs must be held Tri-state/Tri-state on the next $\overline{\text{DIF}}$ high-to-low transition. The device will put all outputs in high impedance mode, and all outputs will be pulled low by the external terminating resistors.

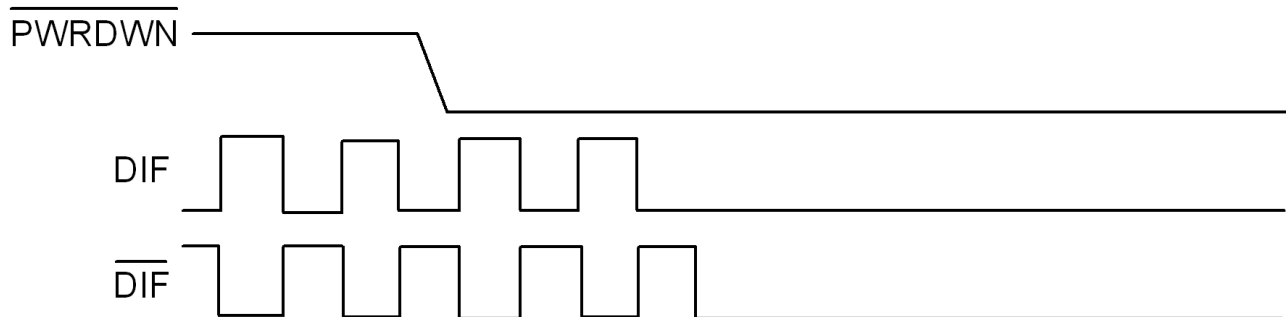

Figure 2. $\overline{\text{PWRDN}}$ Assertion

2.4.2. CKPWRGD Assertion

The power-up latency is to be less than 1.8 ms. This is the time from a valid CLK_IN input clock and the assertion of the PWRGD signal to the time that stable clocks are output from the device (PLL locked). All differential outputs stopped in a Tri-state/Tri-state condition resulting from power down must be driven high in less than 300 μs of $\overline{\text{PWRDN}}$ deassertion to a voltage greater than 200 mV.

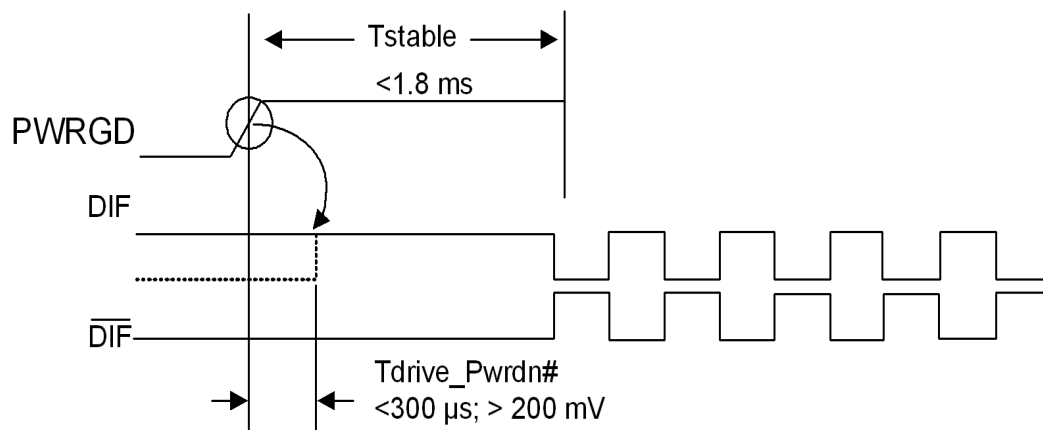

Figure 3. PWRGD Assertion (Pwrdn—Deassertion)

2.5. HBW_BYPASS_LBW

The HBW_BYPASS_LBW pin is a tri-level function input pin (refer to Table 1 for VIL_Tri, VIM_Tri, and VIH_Tri signal levels). It is used to select between PLL high-bandwidth, PLL bypass mode, or PLL low-bandwidth mode. In PLL bypass mode, the input clock is passed directly to the output stage, which may result in up to 50 ps of additive cycle-to-cycle jitter (50 ps + input jitter) on the differential outputs. In the case of PLL mode, the input clock is passed through a PLL to reduce high-frequency jitter. The PLL HBW, BYPASS, and PLL LBW modes may be selected by asserting the HBW_BYPASS_LBW input pin to the appropriate level described in Table 19.

Table 19. PLL Bandwidth and Readback Table

<u>HBW_BYPASS_LBW</u> Pin	Mode	Byte 0, Bit 7	Byte 0, Bit 6
L	LBW	0	0
M	BYPASS	0	1
H	HBW	1	1

The Si53019-A01A has the ability to override the latch value of the PLL operating mode from hardware strap Pin 5 via the use of Byte 0 and Bits 2 and 1. Byte 0 Bit 3 must be set to 1 to allow the user to change Bits 2 and 1, affecting the PLL. Bits 7 and 6 will always read back the original latched value. A warm reset of the system will have to be accomplished if the user changes these bits.

2.6. Miscellaneous Requirements

Data Transfer Rate: 100 kbps (standard mode) is the base functionality required. Fast mode (400 kbps) functionality is optional.

Logic Levels: SMBus logic levels are based on a percentage of V_{DD} for the controller and other devices on the bus. Assume all devices are based on a 3.3 V supply.

Clock Stretching: The clock buffer must not hold/stretch the SCL or SDA lines low for more than 10 ms. Clock stretching is discouraged and should only be used as a last resort. Stretching the clock/data lines for longer than this time puts the device in an error/time-out mode and may not be supported in all platforms. It is assumed that all data transfers can be completed as specified without the use of clock/data stretching.

General Call: It is assumed that the clock buffer will not have to respond to the “general call.”

Electrical Characteristics: All electrical characteristics must meet the standard mode specifications found in Section 3 of the SMBus 2.0 specification.

Pull-Up Resistors: Any internal resistor pull-ups on the SDATA and SCLK inputs must be stated in the individual data sheet. The use of internal pull-ups on these pins of below 100 K is discouraged. Assume that the board designer will use a single external pull-up resistor for each line and that these values are in the 5–6 k Ω range. Assume one SMBus device per DIMM (serial presence detect), one SMBus controller, one clock buffer, one clock driver plus one/two more SMBus devices on the platform for capacitive loading purposes.

Input Glitch Filters: Only fast mode SMBus devices require input glitch filters to suppress bus noise. The clock buffer is specified as a standard mode device and is not required to support this feature. However, it is considered a good design practice to include the filters.

PWRDN: If a clock buffer is placed in PWRDN mode, the SDATA and SCLK inputs must be Tri-stated and the device must retain all programming information. I_{DD} current due to the SMBus circuitry must be characterized and in the data sheet.

3. Test and Measurement Setup

3.1. Input Edge

Input edge rate is based on single-ended measurement. This is the minimum input edge rate at which the Si53019-A01A is guaranteed to meet all performance specifications.

Table 20. Input Edge Rate

Frequency	Min	Max	Unit
100 MHz	0.35	N/A	V/ns
133 MHz	0.35	N/A	V/ns

3.1.1. Measurement Points for Differential

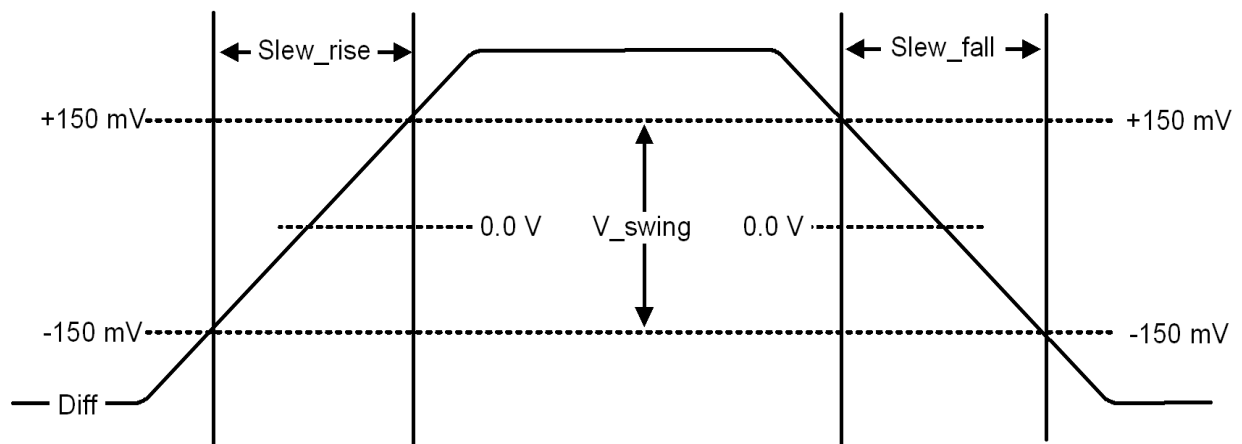

Figure 4. Measurement Points for Rise Time and Fall Time

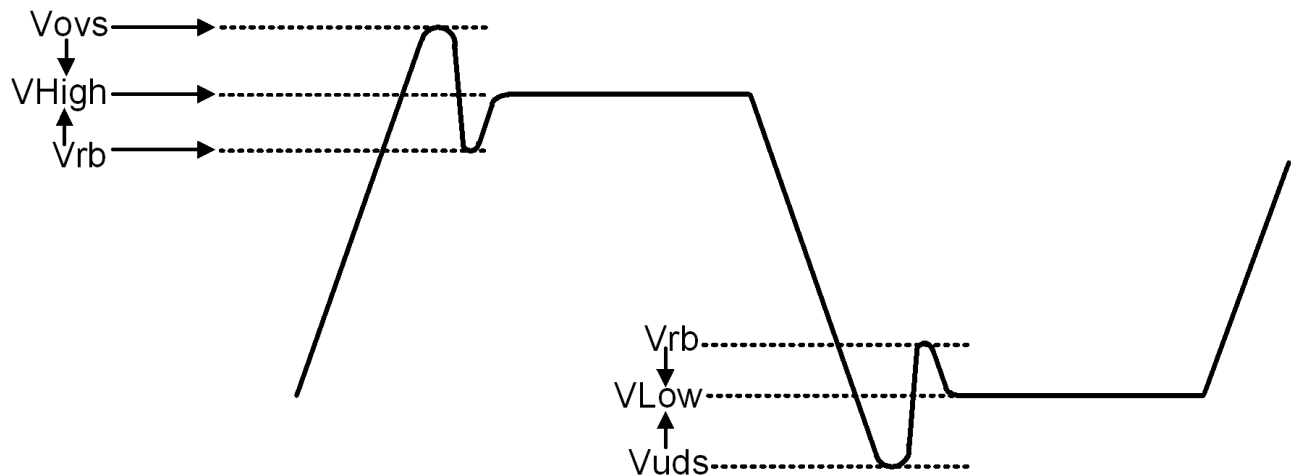

Figure 5. Single-ended Measurement Points for V_{OVS} , V_{uds} , V_{rb}

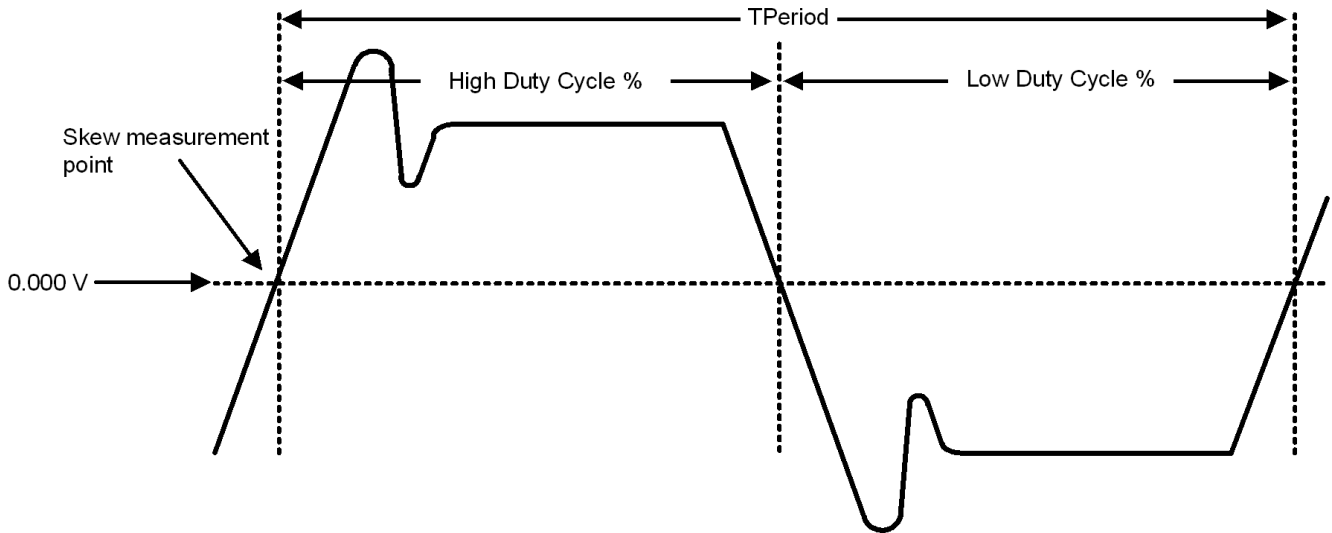

Figure 6. Differential (CLOCK-CLOCK) Measurement Points (T_{period} , Duty Cycle, Jitter)

3.2. Termination of Differential Outputs

All differential outputs are to be tested into a 100 Ω or 85 Ω differential impedance transmission line. Source terminated clocks have some inherent limitations as to the maximum trace length and frequencies that can be supported. For CPU outputs, a maximum trace length of 10" and a maximum of 200 MHz are assumed. For SRC clocks, a maximum trace length of 16" and maximum frequency of 100 MHz is assumed. For frequencies beyond 200 MHz, trace lengths must be restricted to avoid signal integrity problems.

Table 21. Differential Output Termination

Clock	IREF (Ω)	Board Trace Impedance	Rs	Rp	Unit
DIFF Clocks—50 Ω configuration	475	100	33 \pm 5%	50	Ω
DIFF Clocks—43 Ω configuration	412	85	27 \pm 5%	42.2 or 43.2	Ω

3.2.1. Termination of Differential Current Mode HCSL Outputs

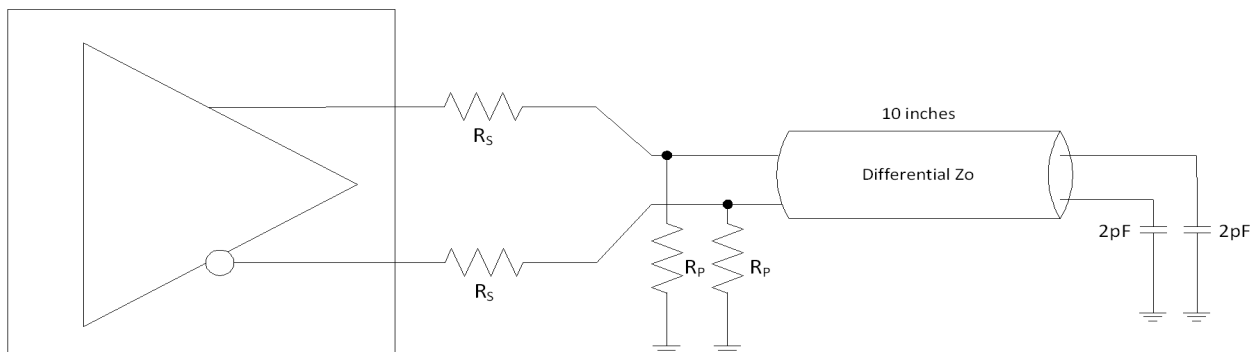

Figure 7. 0.7 V Configuration Test Load Board Termination

4.2. Block Read/Write

4.2.1. Block Read

After the slave address is sent with the R/W condition bit set, the command byte is sent with the MSB = 0. The slave acknowledges the register index in the command byte. The master sends a repeat start function. After the slave acknowledges this, the slave sends the number of bytes it wants to transfer (>0 and <33). The master acknowledges each byte except the last and sends a stop function.

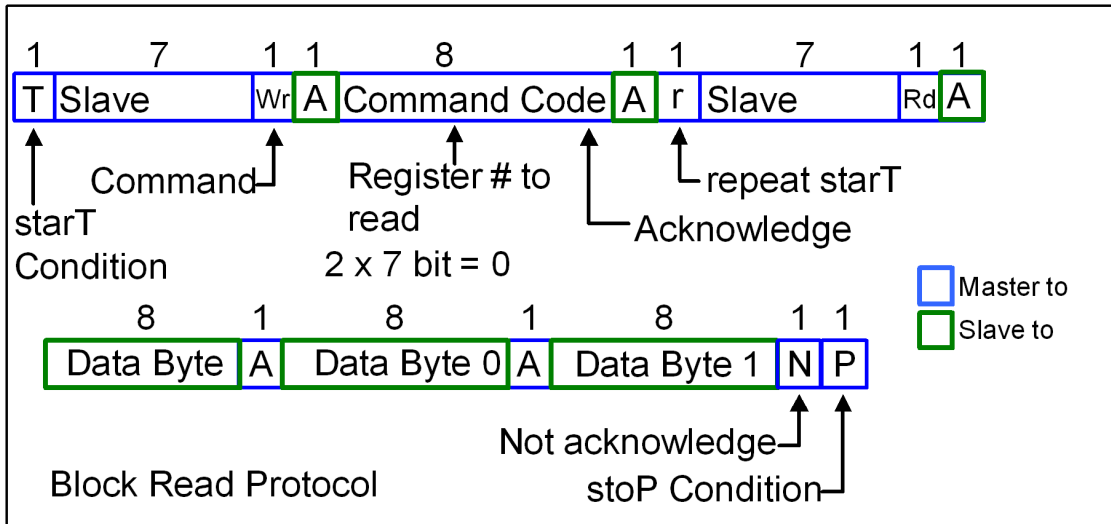

Figure 10. Block Read Protocol

4.2.2. Block Write

After the slave address is sent with the R/W condition bit not set, the command byte is sent with the MSB = 0. The lower seven bits indicate the register at which to start the transfer. If the command byte is 00h, the slave device will be compatible with existing block mode slave devices. The next byte of a write must be the count of bytes that the master will transfer to the slave device. The byte count must be greater than zero and less than 33. Following this byte are the data bytes to be transferred to the slave device. The slave device always acknowledges each byte received. The transfer is terminated after the slave sends the ACK and the master sends a stop function.

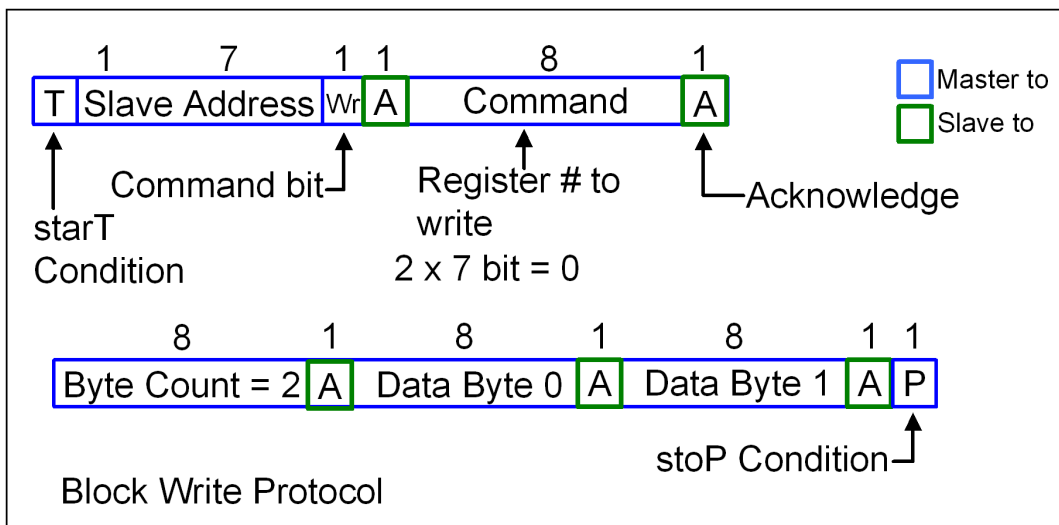

Figure 11. Block Write Protocol

4.3. Control Registers

Table 22. Byte 0: PLL Mode and Frequency Select Register

Bit	Pin #	Name	Control Function	0	1	Type	Default	
0	4	100M_133M#	Frequency Select Readback	133 MHz	100 MHz	R	Latch	
1		reserved						0
2		reserved						0
3	67/66	Output Enable DIF 16	Output control, overrides OE# pin				1	
4	70/69	Output Enable DIF 17	Output control, overrides OE# pin				1	
5	72/71	Output Enable DIF 18	Output control, overrides OE# pin				1	
6	5	PLL Mode 0	PLL operating mode readback 0	See PLL operating mode readback table		R	Latch	
7	5	PLL Mode1	PLL operating mode readback 1			R	Latch	

Table 23. Byte 1: Output Enable Control Register

Bit	Pin #	Description		If Bit = 0	If Bit = 1	Type	Default
0	19/20	Output Enable DIF 0	Output control, overrides OE# pin	Hi-Z	Enabled	RW	1
1	22/23	Output Enable DIF 1	Output control, overrides OE# pin			RW	1
2	24/25	Output Enable DIF 2	Output control, overrides OE# pin			RW	1
3	27/28	Output Enable DIF 3	Output control, overrides OE# pin			RW	1
4	29/30	Output Enable DIF 4	Output control, overrides OE# pin			RW	1
5	32/33	Output Enable DIF 5	Output control, overrides OE# pin			RW	1
6	35/36	Output Enable DIF 6	Output control, overrides OE# pin			RW	1
7	39/38	Output Enable DIF 7	Output control, overrides OE# pin			RW	1

Table 24. Byte 2: Output Enable Control Register

Bit	Pin #	Description	Control Function	If Bit = 0	If Bit = 1	Type	Default
0	42/41	Output Enable DIF 8	Output control, overrides OE# pin	Hi-Z	Enabled	RW	1
1	47/46	Output Enable DIF 9	Output control, overrides OE# pin			RW	1
2	50/49	Output Enable DIF 10	Output control, overrides OE# pin			RW	1
3	53/52	Output Enable DIF 11	Output control, overrides OE# pin			RW	1
4	56/55	Output Enable DIF 12	Output control, overrides OE# pin			RW	1
5	60/59	Output Enable DIF 13	Output control, overrides OE# pin			RW	1
6	62/61	Output Enable DIF 14	Output control, overrides OE# pin			RW	1
7	65/64	Output Enable DIF 15	Output control, overrides OE# pin			RW	1

Table 25. Byte 3: Output Enable Pin Status Readback Register

Bit	Pin #	Description	Control Function	If Bit = 0	If Bit = 1	Type	Default
0	34	OE_RB5	Real time readback of OE5	OE# pin Low	OE# pin High	R	Real Time
1	37	OE_RB6	Real time readback of OE6			R	Real Time
2	40	OE_RB7	Real time readback of OE7			R	Real Time
3	43	OE_RB8	Real time readback of OE8			R	Real Time
4	48	OE_RB9	Real time readback of OE9			R	Real Time
5	51	OE_RB10	Real time readback of OE10			R	Real Time
6	54	OE_RB11	Real time readback of OE11			R	Real Time
7	57	OE_RB12	Real time readback of OE12			R	Real Time

Table 26. Byte 4: Reserved Control Register

Bit	Pin #	Description	Control Function	If Bit = 0	If Bit = 1	Type	Default
0			Reserved				0
1			Reserved				0
2			Reserved				0
3			Reserved				0
4			Reserved				0
5			Reserved				0
6			Reserved				0
7			Reserved				0

Table 27. Byte 5: Vendor/Revision Identification Control Register

Bit	Pin #	Description	Control Function	If Bit = 0	If Bit = 1	Type	Default
0	—	Vendor ID Bit 0	Vendor ID			R	0
1	—	Vendor ID Bit 1				R	0
2	—	Vendor ID Bit 2				R	0
3	—	Vendor ID Bit 3				R	1
4	—	Revision Code Bit 0	Revision ID	-A01A = 0001 -A02A = 0010		R	X
5	—	Revision Code Bit 1				R	X
6	—	Revision Code Bit 2				R	X
7	—	Revision Code Bit 3				R	X

Table 28. Byte 6: Device ID Control Register

Bit	Pin #	Description	Control Function	If Bit = 0	If Bit = 1	Type	Default
0	—	Device ID 0				R	1
1	—	Device ID 1				R	1
2	—	Device ID 2				R	1
3	—	Device ID 3				R	0
4	—	Device ID 4				R	0
5	—	Device ID 5				R	1
6	—	Device ID 6				R	1
7	—	Device ID 7 (MSB)				R	1

Table 29. Byte 7: Byte Count Register

Bit	Pin #	Description	Control Functions	If Bit = 0	If Bit = 1	Type	Default
0	—	BC0	Writing to this register configures how many bytes will be read back.	Default value is 8 hex, so 9 bytes (0 to 8) will be read back by default.		RW	0
1	—	BC1				RW	0
2	—	BC2				RW	0
3	—	BC3				RW	1
4	—	BC4				RW	0
5			Reserved				0
6			Reserved				0
7			Reserved				0

5. Pin Descriptions: 72-Pin QFN

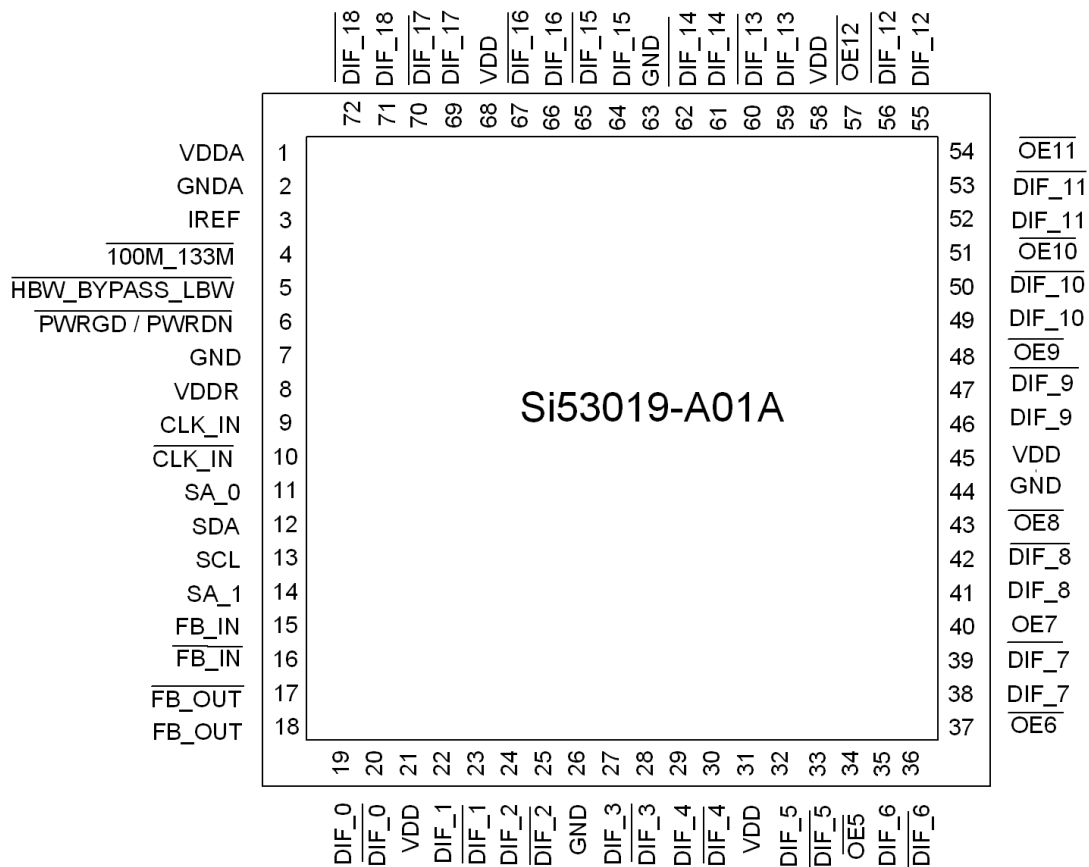

Table 30. Si53019-A01A 72-Pin QFN Descriptions

Pin #	Name	Type	Description
1	VDDA	3.3 V	3.3 V power supply for PLL.
2	GNDA	GND	Ground for PLL.
3	IREF	OUT	This pin establishes the reference for the differential current mode output pairs. It requires a fixed precision resistor to ground. 475 Ω is the standard value for 100 Ω differential impedance. Other impedances require different values.
4	$\overline{100M_133M}$	I,SE	3.3 V tolerant inputs for input/output frequency selection. An external pull-up or pull-down resistor is attached to this pin to select the input/output frequency. High = 100 MHz output Low = 133 MHz output
5	$\overline{HBW_BYPASS_LBW}$	I, SE	Tri-Level input for selecting the PLL bandwidth or bypass mode. High = High BW mode Med = Bypass mode Low = Low BW mode
6	$\overline{PWRGD/PWRDN}$	I	3.3 V LVTTTL input to power up or power down the device.
7	GND	GND	Ground for outputs.
8	VDDR	VDD	3.3 V power supply for differential input receiver. This VDDR should be treated as an analog power rail and filtered appropriately.
9	CLK_IN	I, DIF	0.7 V Differential TRUE input.
10	$\overline{CLK_IN}$	I, DIF	0.7 V Differential input.
11	SA_0	I,PU	3.3 V LVTTTL input selecting the address. Tri-level input.
12	SDA	I/O	Open collector SMBus data.
13	SCL	I/O	SMBus slave clock input.
14	SA_1	I,PU	3.3 V LVTTTL input selecting the address. Tri-level input.
15	FB_IN	I/O	True differential feedback input. Provides feedback signal to the PLL for synchronization with the input clock to eliminate phase error.
16	$\overline{FB_IN}$	I/O	Complementary differential feedback input. Provides feedback signal to the PLL for synchronization with the input clock to eliminate phase error.
17	$\overline{FB_OUT}$	I/O	Complementary differential feedback output, provides feedback signal to the PLL for synchronization with input clock to eliminate phase error.
18	FB_OUT	I/O	True differential feedback output, provides feedback signal to the PLL for synchronization with the input clock to eliminate phase error.
19	DIF_0	O, DIF	0.7 V Differential TRUE clock output.
20	$\overline{DIF_0}$	O, DIF	0.7 V Differential Complimentary clock output.
21	VDD	VDD	Power supply for differential outputs.
22	DIF_1	O, DIF	0.7 V Differential TRUE clock output.

Table 30. Si53019-A01A 72-Pin QFN Descriptions

Pin #	Name	Type	Description
23	$\overline{\text{DIF}}_1$	O, DIF	0.7 V Differential Complimentary clock output.
24	DIF_2	O, DIF	0.7 V Differential TRUE clock output.
25	$\overline{\text{DIF}}_2$	O, DIF	0.7 V Differential Complimentary clock output.
26	GND	GND	Ground for outputs.
27	DIF_3	O, DIF	0.7 V Differential TRUE clock output.
28	$\overline{\text{DIF}}_3$	O, DIF	0.7 V Differential Complimentary clock output.
29	DIF_4	O, DIF	0.7 V Differential TRUE clock output.
30	$\overline{\text{DIF}}_4$	O, DIF	0.7 V Differential Complimentary clock output.
31	VDD	3.3 V	3.3 V power supply
32	DIF_5	O, DIF	0.7 V Differential TRUE clock output.
33	$\overline{\text{DIF}}_5$	O, DIF	0.7 V Differential Complimentary clock output.
34	$\overline{\text{OE}}_5$	IN	Active low input for enabling DIF pair 5 1 = disable outputs, 0 = enable outputs
35	DIF_6	O, DIF	0.7 V Differential TRUE clock output.
36	$\overline{\text{DIF}}_6$	O, DIF	0.7 V Differential Complimentary clock output.
37	$\overline{\text{OE}}_6$	IN	Active low input for enabling DIF pair 6 1 = disable outputs, 0 = enable outputs
38	DIF_7	O, DIF	0.7 V Differential TRUE clock output.
39	$\overline{\text{DIF}}_7$	O, DIF	0.7 V Differential Complimentary clock output.
40	$\overline{\text{OE}}_7$	IN	Active low input for enabling DIF pair 7 1 = disable outputs, 0 = enable outputs
41	DIF_8	O, DIF	0.7 V Differential TRUE clock output.
42	$\overline{\text{DIF}}_8$	O, DIF	0.7 V Differential Complimentary clock output.
43	$\overline{\text{OE}}_8$	IN	Active low input for enabling DIF pair 8 1 = disable outputs, 0 = enable outputs
44	GND	GND	Ground for outputs.
45	VDD	3.3 V	3.3 V power supply
46	DIF_9	O, DIF	0.7 V Differential TRUE clock output.
47	$\overline{\text{DIF}}_9$	O, DIF	0.7 V Differential Complimentary clock output.
48	$\overline{\text{OE}}_9$	IN	Active low input for enabling DIF pair 9 1 = disable outputs, 0 = enable outputs
49	DIF_10	O, DIF	0.7 V Differential TRUE clock output.

Table 30. Si53019-A01A 72-Pin QFN Descriptions

Pin #	Name	Type	Description
50	$\overline{\text{DIF}}_{10}$	O, DIF	0.7 V Differential Complimentary clock output.
51	$\overline{\text{OE}}_{10}$	IN	Active low input for enabling DIF pair 10 1 = disable outputs, 0 = enable outputs
52	DIF_11	O, DIF	0.7 V Differential TRUE clock output.
53	$\overline{\text{DIF}}_{11}$	O, DIF	0.7 V Differential Complimentary clock output.
54	$\overline{\text{OE}}_{11}$	IN	Active low input for enabling DIF pair 11 1 = disable outputs, 0 = enable outputs
55	DIF_12	O, DIF	0.7 V Differential TRUE clock output.
56	$\overline{\text{DIF}}_{12}$	O, DIF	0.7 V Differential Complimentary clock output.
57	$\overline{\text{OE}}_{12}$	IN	Active low input for enabling DIF pair 12 1 = disable outputs, 0 = enable outputs
58	VDD	3.3 V	3.3 V power supply
59	DIF_13	O, DIF	0.7 V Differential TRUE clock output.
60	$\overline{\text{DIF}}_{13}$	O, DIF	0.7 V Differential Complimentary clock output.
61	DIF_14	O, DIF	0.7 V Differential TRUE clock output.
62	$\overline{\text{DIF}}_{14}$	O, DIF	0.7 V Differential Complimentary clock output.
63	GND	GND	Ground for outputs.
64	DIF_15	O, DIF	0.7 V Differential TRUE clock output.
65	$\overline{\text{DIF}}_{15}$	O, DIF	0.7 V Differential Complimentary clock output.
66	DIF_16	O, DIF	0.7 V Differential TRUE clock output.
67	$\overline{\text{DIF}}_{16}$	O, DIF	0.7 V Differential Complimentary clock output.
68	VDD	3.3 V	3.3 V power supply
69	DIF_17	O, DIF	0.7 V Differential TRUE clock output.
70	$\overline{\text{DIF}}_{17}$	O, DIF	0.7 V Differential Complimentary clock output.
71	DIF_18	O, DIF	0.7 V Differential TRUE clock output.
72	$\overline{\text{DIF}}_{18}$	O, DIF	0.7 V Differential Complimentary clock output.
73	GND	GND	Ground for outputs.

6. Power Filtering Example

6.1. Ferrite Bead Power Filtering

Recommended ferrite bead filtering equivalent to the following:

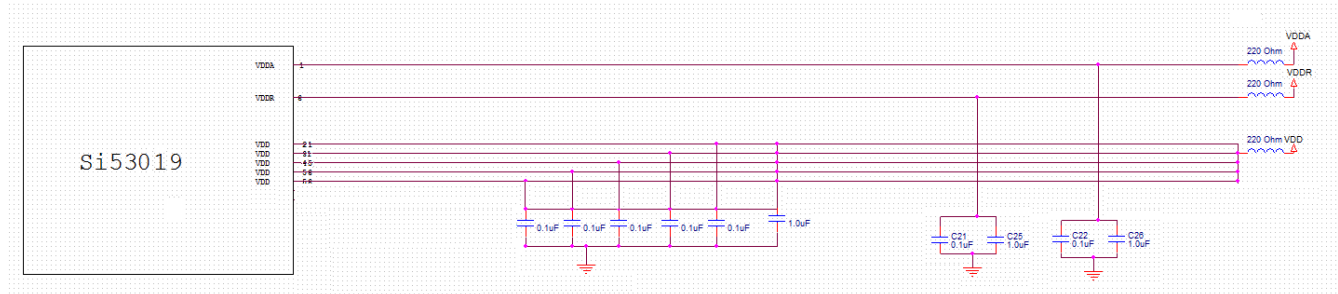

Figure 12. Schematic Example of the Si53019-A01A Power Filtering

Si53019-A01A

7. Ordering Guide

Part Number	Package Type	Temperature
Lead-free		
Si53019-A01AGM	72-pin QFN	Extended, -40 to 85 °C
Si53019-A01AGMR	72-pin QFN—Tape and Reel	Extended, -40 to 85 °C

8. Package Outline

Figure 13 illustrates the package details for the Si53019-A01A. Table 31 lists the values for the dimensions shown in the illustration.

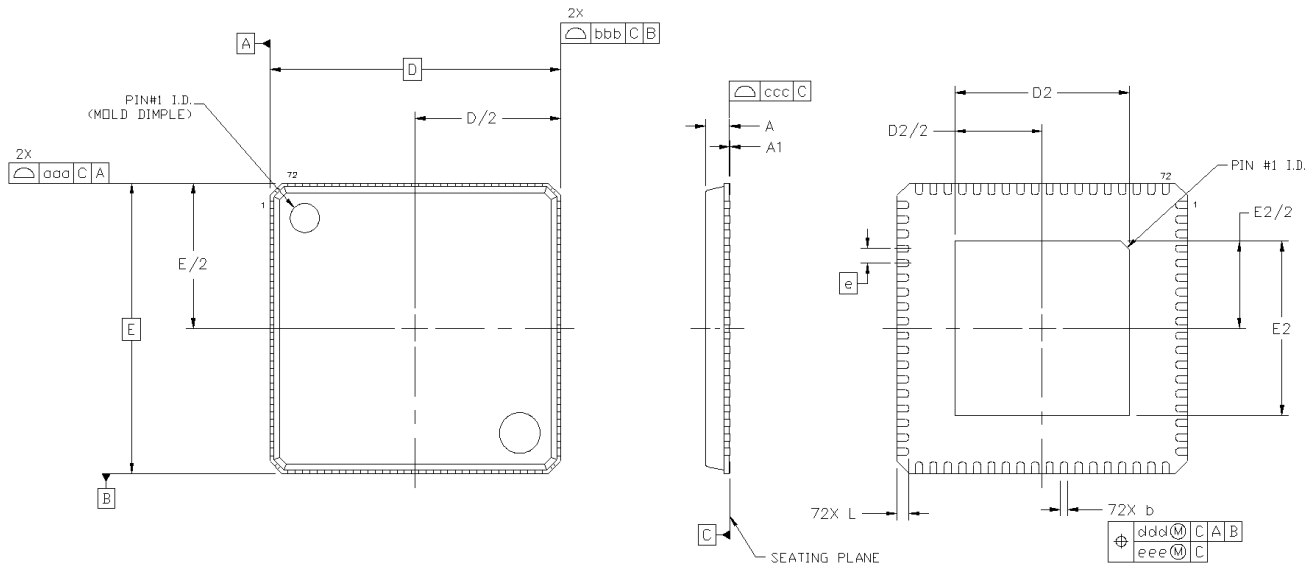

Figure 13. 72-Pin Quad Flat No Lead (QFN) Package

Table 31. Package Diagram Dimensions ^{1,2,3,4}

Dimension	Min	Nom	Max	Dimension	Min	Nom	Max
A	0.80	0.85	0.90	E2	5.90	6.00	6.10
A1	0.00	0.02	0.05	L	0.30	0.40	0.50
b	0.18	0.25	0.30	aaa	0.10		
D	10.00 BSC.			bbb	0.10		
D2	5.90	6.00	6.10	ccc	0.08		
e	0.50 BSC.			ddd	0.10		
E	10.00 BSC.			eee	0.05		

Notes:

1. All dimensions shown are in millimeters (mm) unless otherwise noted.
2. Dimensioning and Tolerancing per ANSI Y14.5M-1994.
3. This drawing conforms to JEDEC outline MO-220.
4. Recommended card reflow profile is per the JEDEC/IPC J-STD-020 specification for Small Body Components.

9. PCB Land Pattern

9.1. 10x10 mm 72-QFN Package Land Pattern

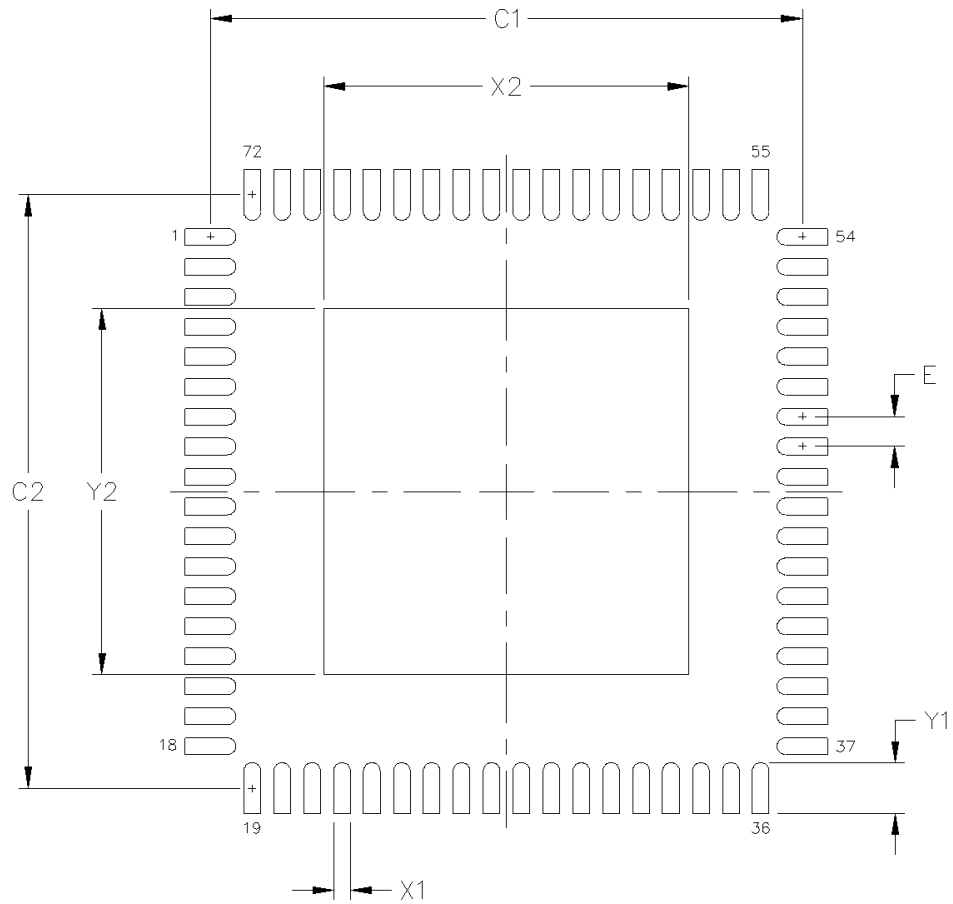

Table 32. PCB Land Pattern

Dimension	mm
C1	9.90
C2	9.90
E	0.50
X1	0.30
Y1	0.85
X2	6.10
Y2	6.10

Notes:

General

1. All dimensions shown are in millimeters (mm).
2. This Land Pattern Design is based on the IPC-7351 guidelines.
3. All dimensions shown are at Maximum Material Condition (MMC). Least Material Condition (LMC) is calculated based on a Fabrication Allowance of 0.05mm.

Solder Mask Design

4. All metal pads are to be non-solder mask defined (NSMD). Clearance between the solder mask and the metal pad is to be 60 μm minimum, all the way around the pad.

Stencil Design

5. A stainless steel, laser-cut and electro-polished stencil with trapezoidal walls should be used to assure good solder paste release.
6. The stencil thickness should be 0.125 mm (5 mils).
7. The ratio of stencil aperture to land pad size should be 1:1 for all pads.
8. A 3x3 array of 1.45 mm square openings on 2.00 mm pitch should be used for the center ground pad.

Card Assembly

9. A No-Clean, Type-3 solder paste is recommended.
10. The recommended card reflow profile is per the JEDEC/IPC J-STD-020 specification for Small Body Components.

DOCUMENT CHANGE LIST

Revision 1.0 to Revision 1.1

- Updated descriptions for pin15, pin16, pin17, and pin18 in Table 30.

Revision 1.1 to Revision 1.2

- Updated Features on page 1.
- Updated Description on page 1.
- Updated specs in Table 7, “Phase Jitter,” on page 10.
- Updated the package drawing and table.

Revision 1.2 to Revision 1.3

January 20, 2016

- Updated the package drawing and table.
- Updated the land pattern drawing and table.
- Correct specs in Table 1 on page 4.

Revision 1.3 to Revision 1.4

February 22, 2016

- Updated operating characteristics in Table 4, Table 5, Table 6, and Table 14.

Revision 1.4 to Revision 1.5

July 20, 2017

- Updated Input Amplitude max spec in Table 5 to 1900 mV.

Revision 1.5 to Revision 1.6

March, 2018

- Corrected vendor ID in Table 27 on page 25.
- Corrected device ID from DB to E7 in Table 28 on page 25.



ClockBuilder Pro

One-click access to Timing tools, documentation, software, source code libraries & more. Available for Windows and iOS (CBGo only).

www.silabs.com/CBPro



Timing Portfolio
www.silabs.com/timing



SW/HW
www.silabs.com/CBPro



Quality
www.silabs.com/quality



Support and Community
community.silabs.com

Disclaimer

Silicon Laboratories intends to provide customers with the latest, accurate, and in-depth documentation of all peripherals and modules available for system and software implementers using or intending to use the Silicon Laboratories products. Characterization data, available modules and peripherals, memory sizes and memory addresses refer to each specific device, and "Typical" parameters provided can and do vary in different applications. Application examples described herein are for illustrative purposes only. Silicon Laboratories reserves the right to make changes without further notice and limitation to product information, specifications, and descriptions herein, and does not give warranties as to the accuracy or completeness of the included information. Silicon Laboratories shall have no liability for the consequences of use of the information supplied herein. This document does not imply or express copyright licenses granted hereunder to design or fabricate any integrated circuits. The products are not designed or authorized to be used within any Life Support System without the specific written consent of Silicon Laboratories. A "Life Support System" is any product or system intended to support or sustain life and/or health, which, if it fails, can be reasonably expected to result in significant personal injury or death. Silicon Laboratories products are not designed or authorized for military applications. Silicon Laboratories products shall under no circumstances be used in weapons of mass destruction including (but not limited to) nuclear, biological or chemical weapons, or missiles capable of delivering such weapons.

Trademark Information

Silicon Laboratories Inc.®, Silicon Laboratories®, Silicon Labs®, SiLabs® and the Silicon Labs logo®, Bluegiga®, Bluegiga Logo®, Clockbuilder®, CMEMS®, DSPLL®, EFM®, EFM32®, EFR®, Ember®, Energy Micro, Energy Micro logo and combinations thereof, "the world's most energy friendly microcontrollers", Ember®, EZLink®, EZRadio®, EZRadioPRO®, Gecko®, ISOModem®, Precision32®, ProSLIC®, Simplicity Studio®, SiPHY®, Telegesis, the Telegesis Logo®, USBXpress® and others are trademarks or registered trademarks of Silicon Laboratories Inc. ARM, CORTEX, Cortex-M3 and THUMB are trademarks or registered trademarks of ARM Holdings. Keil is a registered trademark of ARM Limited. All other products or brand names mentioned herein are trademarks of their respective holders.



Silicon Laboratories Inc.
400 West Cesar Chavez
Austin, TX 78701
USA

<http://www.silabs.com>



Компания «ЭлектроПласт» предлагает заключение долгосрочных отношений при поставках импортных электронных компонентов на взаимовыгодных условиях!

Наши преимущества:

- Оперативные поставки широкого спектра электронных компонентов отечественного и импортного производства напрямую от производителей и с крупнейших мировых складов;
- Поставка более 17-ти миллионов наименований электронных компонентов;
- Поставка сложных, дефицитных, либо снятых с производства позиций;
- Оперативные сроки поставки под заказ (от 5 рабочих дней);
- Экспресс доставка в любую точку России;
- Техническая поддержка проекта, помощь в подборе аналогов, поставка прототипов;
- Система менеджмента качества сертифицирована по Международному стандарту ISO 9001;
- Лицензия ФСБ на осуществление работ с использованием сведений, составляющих государственную тайну;
- Поставка специализированных компонентов (Xilinx, Altera, Analog Devices, Intersil, Interpoint, Microsemi, Aeroflex, Peregrine, Syfer, Eurofarad, Texas Instrument, Miteq, Cobham, E2V, MA-COM, Hittite, Mini-Circuits, General Dynamics и др.);

Помимо этого, одним из направлений компании «ЭлектроПласт» является направление «Источники питания». Мы предлагаем Вам помощь Конструкторского отдела:

- Подбор оптимального решения, техническое обоснование при выборе компонента;
- Подбор аналогов;
- Консультации по применению компонента;
- Поставка образцов и прототипов;
- Техническая поддержка проекта;
- Защита от снятия компонента с производства.



Как с нами связаться

Телефон: 8 (812) 309 58 32 (многоканальный)

Факс: 8 (812) 320-02-42

Электронная почта: org@eplast1.ru

Адрес: 198099, г. Санкт-Петербург, ул. Калинина, дом 2, корпус 4, литера А.