

Product Overview

The QPF7200 provides a complete integrated solution in a single placement front end module (FEM) for Wi-Fi 802.11b/g/n systems. The full integration minimizes layout area in the customer's application and greatly reduces the design complexity and the number of external components. Performance is focused on conserving power consumption while maintaining the highest linear output power and leading edge throughput across all Wi-Fi channels without the need to reduce transmit power to meet the FCC regulatory limits. The QPF7200 integrates a 2.4GHz power amplifier (PA) with power detector, multiple switches, LNA with bypass mode, transmit bandedge BAW filter for flat power transmission, and receive BAW filter for wireless coexistence. The QPF7200 integrated filtering also includes 2nd and 3rd harmonics and 5GHz rejection for dual-band dual-concurrent operation. The device is provided in a 8.0mm x 5.5mm x 1mm max laminate package. This module meets or exceeds the RF front end needs of IEEE 802.11b/g/n Wi-Fi RF systems.



20-pin 8.0mm x 5.5mm x 1mm leadless SMT Package

Key Features

- Fully integrated front end module that includes highly selective BAW filters achieving FCC bandedge and coexistence attenuation over operating conditions.
- Optimized for 5V Operation
- 37 dB Tx Gain
- 2 dB Rx Noise Figure
- Pout = +25dBm, 802.11n, MCS7 -30dB EVM (Bandedge Compliant CH1 -11)

Functional Block Diagram

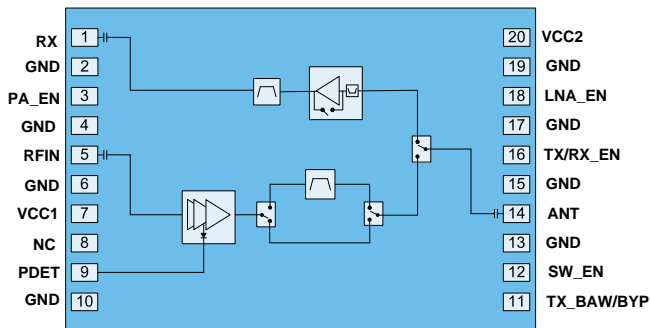

Applications

- IEEE 802.11b/g/n WLAN Applications
- Wi-Fi Consumer Premise Equipment
- Access Points
- Wireless Routers
- Residential Gateways
- Internet of Things

Ordering Information

Part Number	Description
QPF7200SB	Sample bag with 5 pieces
QPF7200SQ	Sample bag with 25 pieces
QPF7200SR	7" Reel with 100 pieces
QPF7200TR7	7" Reel with 2500 pieces
QPF7200PCBA-410	Assembled Evaluation Board



Absolute Maximum Ratings

Parameter	Rating	Unit
Storage Temperature	-40 to 125	°C
Case Temperature, Survival	-40 to 100	°C
RF Input Power, 11b/g/n (No Damage), 50Ω, Vcc=5V	+5	dBm
DC Supply Voltage (No RF Applied)	-0.5 to +6.0	VDC
DC Supply Current	1.1	A
LNA On Maximum RX input power (No damage), 50Ω, Vcc=5V	+15	dBm
Bypass Mode Maximum RX input power (No damage), 50Ω, T = 25°C, Vcc=5V	+25	dBm
Moisture Sensitivity	MSL3	

Operation of this device outside the parameter ranges given above may cause permanent damage.

Recommended Operating Conditions

Parameter	Conditions	Min.	Typ.	Max.	Units
Compliance	802.11b/g/n				
Operating Frequency	CH1-Ch13	2402.0		2481.5	MHz
Operating Temperature		-20		+95	°C
Power Supply VCC1		3.6	5.0	5.25	V
Power Supply VCC2		3.0	3.3	3.6	V
Control Voltage-High	PA_EN, LNA_EN, TX/RX_EN, SW_EN, TX_BAW/BYP	2.9	3.0	3.1	V
Control Voltage-Low	PA_EN, LNA_EN, TX/RX_EN, SW_EN, TX_BAW/BYP		0	0.2	V

Degraded performance at extended operating range.

Logic Truth Table

Operating Mode	PA_EN	LNA_EN	TX/RX_EN	SW_EN	TX_BAW/BYP
Standby	0	0	0	0	0
802.11a/n TX BAW Mode	1	0	0	1	0
802.11a/n TX Bypass Mode	1	0	0	1	1
802.11a/n RX Gain Mode	0	1	1	1	0
802.11a/n RX Bypass Mode	0	0	1	1	0



Electrical Specifications – Transmit (TX-ANT) Through Tx BAW

Parameter	Conditions	Min.	Typ.	Max.	Units	
	VCC1=5V, VCC2=3.3V, T=+25°C; f = 2402-2472MHz Through Tx BAW Filter, only CH1-11					
Logic Truth	PA_EN=1, LNA_EN=0, TX/RX_EN=0, SW_EN=1, TX_BAW/BYP=0					
Small Signal Gain			37		dB	
Large Signal Gain	Pout = +25dBm		37		dB	
Gain Flatness	For any 40MHz channel over frequency range	-0.25	-	+0.25	dB	
Gain Flatness	For entire frequency range	-1	-	+1	dB	
Dynamic EVM	11n HT20 MCS7 64QAM	Pout	+24	+24.5	-	dBm
				-31	-30	dB
Dynamic EVM	11n HT40 MCS7 64QAM	Pout	+24	+24.5	-	dBm
				-31	-30	dB
Margin to Spectral Mask	Pout = +25dBm, 802.11n 20MHz MCS0		3	0	dBc	
Input Return Loss			12		dB	
Output Return Loss			12		dB	
Operating Current	Pout = 24dBm, 802.11n MCS7 HT20/40		650		mA	
Quiescent Current	RF=Off, TX mode		250		mA	
TX Harmonics (2f ₀)	Pout = +25dBm 802.11b 1MBps			-50	dBm/MHz	
TX Harmonics (3f ₀)	Pout = +25dBm 802.11b 1MBps			-50	dBm/MHz	
Power Detector Voltage	Pout = +0dBm		0.173		V	
	Pout = +15dBm		0.247			
	Pout = +20dBm		0.316			
	Pout = +24dBm		0.405			
	Pout = +27dBm		0.562			
FCC Restricted Band Edge(conducted measurement)	FEM Pout = +24dBm	-	-50	-	dBm/MHz	
OOB Gain	2390MHz		5		dB	
	2483.5MHz		13		dB	
	4800 - 5000MHz		-45		dB	
	5120 - 6000MHz		-45		dB	
	1.60 - 1.95 GHz		0		dB	
	3.2 - 3.9GHz		-5		dB	
	7GHz		-45		dB	

Electrical Specifications – Transmit (TX-ANT) Bypassing Tx BAW

Parameter	Conditions				Units
	VCC1=5V, VCC2=3.3V, T=+25°C; f = 2467-2472 MHz Bypassing Tx BAW Filter, CH12-13 only	Min.	Typ.	Max.	
Logic Truth	PA_EN=1, LNA_EN=0, TX/RX_EN=0, SW_EN=1, TX_BAW/BYP=1				
Small Signal Gain			38		dB
Large Signal Gain	Pout = 20 dBm		38		dB
Gain Flatness	For any 40MHz channel over freq. range	-0.25	-	+0.25	dB
Gain Flatness	For entire frequency band	-1	-	+1	dB
Dynamic EVM	Pout 11n HT20 MCS7 64QAM		+20	-	dBm
Dynamic EVM	Pout 11n HT40 MCS7 64QAM		-31	-30	dB
Dynamic EVM	Pout 11n HT40 MCS7 64QAM		+20	-	dBm
Dynamic EVM	Pout 11n HT40 MCS7 64QAM		-31	-30	dB
Margin to Spectral Mask	Pout = +20 dBm, 802.11n 40MHz MCS0		2	0	dBc
Margin to Spectral Mask	Pout = +20 dBm, 802.11n 20MHz MCS0		2	0	dBc
Input Return Loss			12		dB
Output Return Loss			12		dB
Operating Current	Pout = 20dBm, 802.11n MCS7 HT20/40		435		mA
Quiescent Current	RF=Off, TX mode		250		mA
TX Harmonics (2f ₀)	Pout = +20dBm 802.11b 1MBps			-40	dBm/MHz
TX Harmonics (3f ₀)	Pout = +20dBm 802.11b 1MBps			-45	dBm/MHz
Power Detector Voltage	Pout = +0dBm Pout = +15dBm Pout = +20dBm Pout = +24dBm Pout = +27dBm		0.171 0.225 0.287 0.360 0.487		V

Electrical Specifications – Receive Mode

Parameter	Conditions	Min.	Typ.	Max.	Units
	VCC1=5V, VCC2=3.3V, T=+25°C; CH1-13				
Frequency Range		2402	-	2481.5	MHz
Gain – LNA mode	LNA Enabled	-	12	-	dB
Gain – Bypass mode	LNA Disabled	-	-8.0	-	dB
Gain Flatness – LNA mode	For any 40 MHz channel over the frequency range. LNA Enabled.	-0.25	-	+0.25	dB
Gain Flatness – Bypass mode	For any 20 MHz channel over the frequency range. LNA Disabled.	-0.25	-	+0.25	dB
Noise Figure – LNA mode	LNA Enabled	-	2.0	-	dB
Current – LNA mode	LNA Enabled	-	15	-	mA
Input IP3 – LNA mode	LNA Enabled	-	2	-	dBm
Input IP3 – Bypass mode	LNA Disabled	-	20	-	dBm
Input P1dB – LNA mode	LNA Enabled	-	-5	-	dBm
Input P1dB – Bypass mode	LNA Disabled	-	+17	-	dBm
OOB Gain (High Gain Mode)	2170 MHz	-	-30	-	dB
	2300 - 2375	-	-38	-	dB
	2500 - 2700	-	-35	-	dB
	4800 - 6000	-	-45	-	dB
LNA turn on/off time	LNA Enabled	-	200	-	nS
Return Loss – RX Port LNA mode	LNA Enabled	-	-8	-	dB
Return Loss – RX Port Bypass mode	LNA Disabled	-	-7	-	dB
Return Loss – ANT Port LNA mode	LNA Enabled	-	-10	-	dB
Return Loss – ANT Port Bypass mode	LNA Disabled	-	-10	-	dB

General Specifications

Parameter	Conditions	Min.	Typ.	Max.	Units
	VCC=5V, T=+25°C; CH1-13				
FEM Leakage Current			1	10	μA
PA_EN Control Current				200	μA
LNA_EN Control Current				200	μA
Other Controls Current			600		μA
Switching Speed				400	nS
ESD – Human Body Model		500			V
ESD – Charge Device Model		500			V
PA Turn-on Time from PA_EN edge	10% to 90% of final gain		200	500	nS
PA Stability	Unconditional into 4:1 VSWR; No spurs above -41.25dBm/MHz				

Evaluation Board Schematic

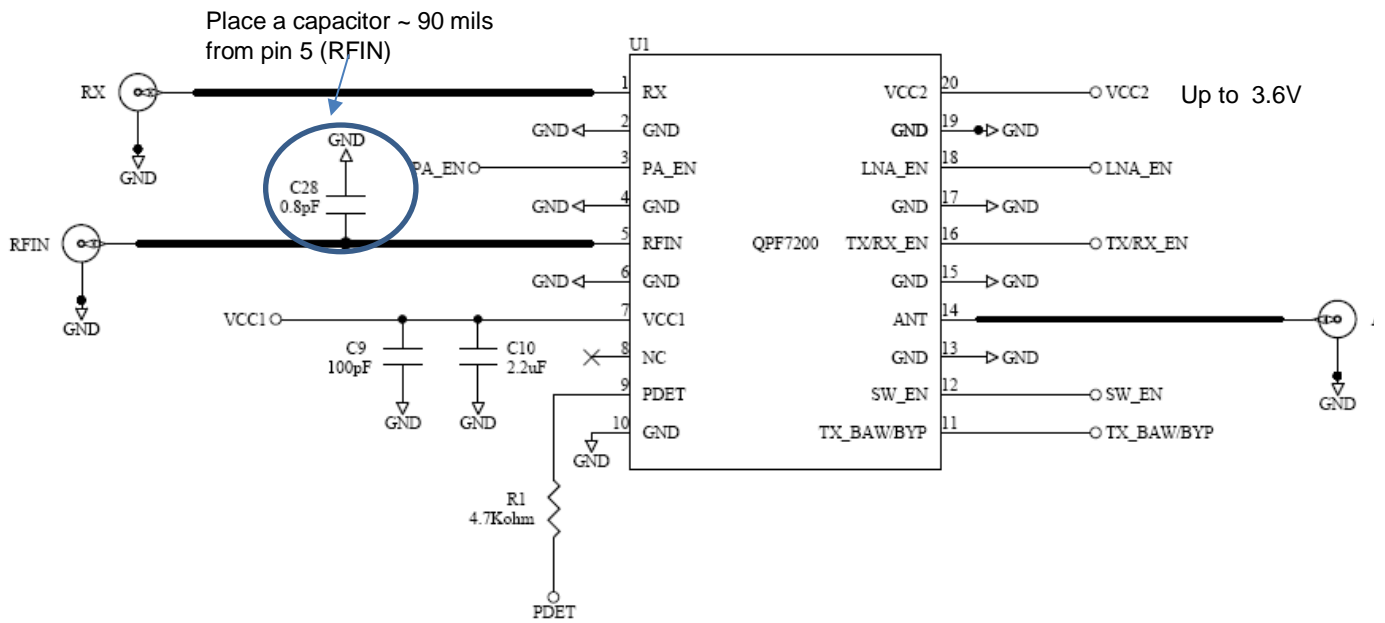

Pin Configuration and Description

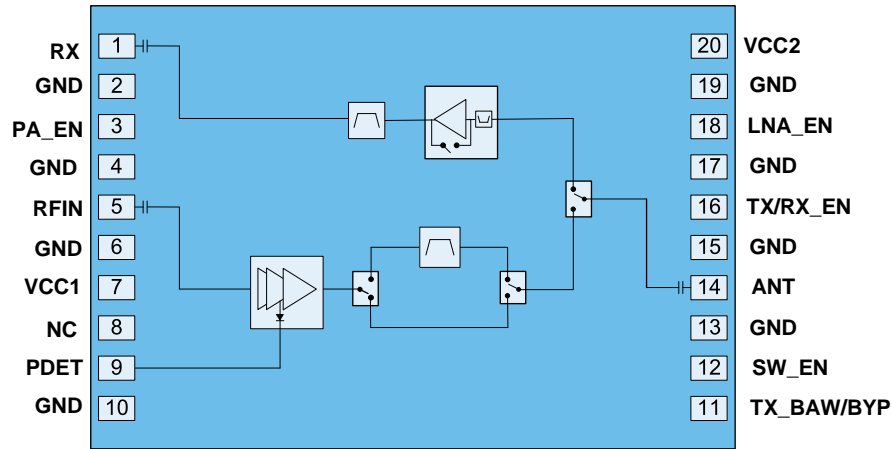

Top View

Pin Number	Label	Description
1	RX	RF output port for the 802.11 LNA. This port is matched to 50Ω and DC blocked internally
2	GND	Ground connection.
3	PA_EN	Enable Pin for the PA. May be pulsed for lower duty cycle operation
4	GND	Ground connection.
5	RFIN	RF input for the TX Chain. This port is matched to 50 Ω and DC blocked internally.
6	GND	Ground connection.
7	VCC1	Supply Rail for PA, 5V Nominal
8	NC	GND on PCB (not internally connected)
9	PDET	Power Detect Voltage
10	GND	Ground connection.
11	TX_BAW/BYP	Path Selection Pin for TX Bypass/ TX Thru BAW
12	SW_EN	Switch Logic Enable Pin. May be tied to Vcc2 if Voltage < 3.3V
13	GND	Ground connection
14	ANT	RF common Port. This port is matched to 50Ω and DC blocked internally
15	GND	Ground connection
16	TX/RX_EN	TX/RX Switch Path Selection Pin
17	GND	Ground connection
18	LNA_EN	LNA High Gain/Bypass Path Selection Pin
19	GND	Ground connection
20	VCC2	Supply Rail for the LNA, and Switches (Limit to 3.3V)
Pkg Base		Ground connection. The backside of the package should be connected to the ground plane through a short path, i.e., PCB vias under the device are recommended.

Package Outline Drawing

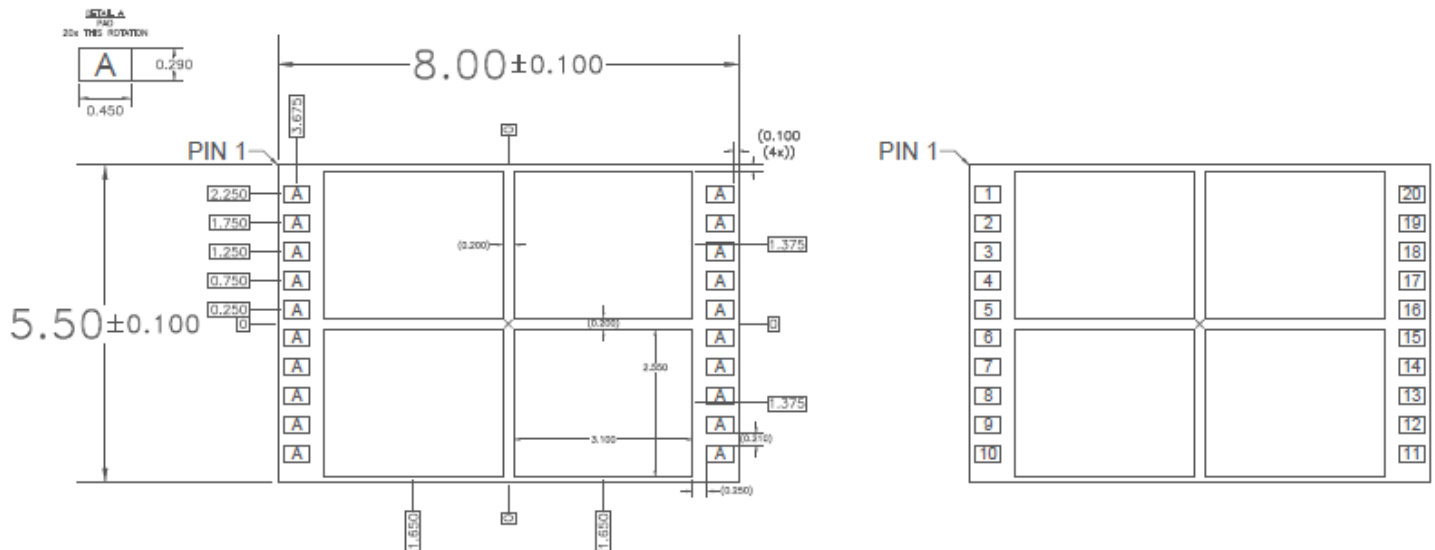

Notes:

1. All dimensions are in mm. Angles are in degrees.
2. Dimension and tolerance formats conform to ASME Y14.4M-1994.
3. The terminal #1 identifier and terminal numbering conform to JESD 95-1 SPP-012.

PCB Mounting Patterns

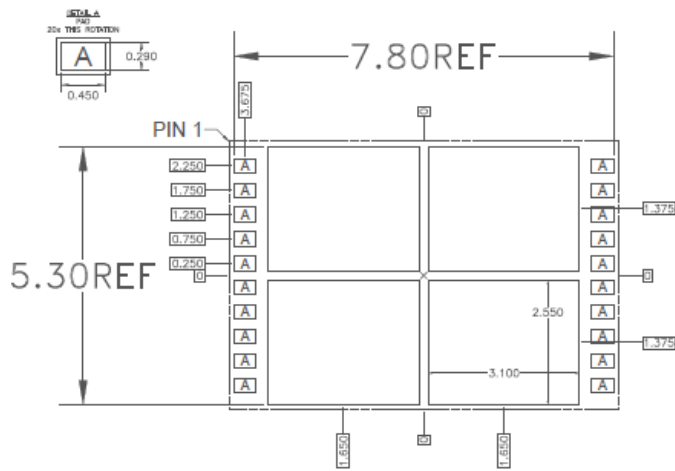

RECOMMENDED
LAND PATTERN

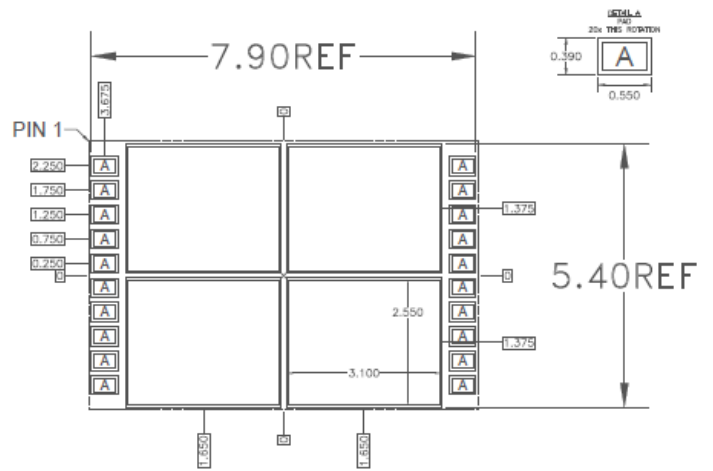

RECOMMENDED
LAND PATTERN MASK

Notes:

1. All dimensions are in mm. Angles are in degrees.
2. Dimension and tolerance formats conform to ASME Y14.4M-1994.
3. The terminal #1 identifier and terminal numbering conform to JESD 95-1 SPP-012.

Handling Precautions

Parameter	Rating	Standard
ESD – Human Body Model (HBM)	tbd	ESDA/JEDEC JS-001-2012
ESD – Charged Device Model (CDM)	tbd	JEDEC JESD22-C101F
MSL – Moisture Sensitivity Level	tbd	IPC/JEDEC J-STD-020



Caution!

ESD sensitive device

Solderability

Compatible with both lead-free (260 °C max. reflow temperature) and tin/lead (245 °C max. reflow temperature) soldering processes.

Package lead plating: Electrolytic plated Au over Ni

RoHS Compliance

This part is compliant with the 2011/65/EU RoHS directive (Restrictions on the Use of Certain Hazardous Substances in Electrical and Electronic Equipment), as amended by Directive 2015/863/EU.

This product also has the following attributes:

- Lead free
- Halogen Free (Chlorine, Bromine)
- Antimony Free
- TBBP-A (C₁₅H₁₂Br₄O₂) Free
- SVHC Free



Contact Information

For the latest specifications, additional product information, worldwide sales and distribution locations:

Web: www.qorvo.com

Tel: 1-844-890-8163

Email: customer.support@qorvo.com

Important Notice

The information contained herein is believed to be reliable; however, Qorvo makes no warranties regarding the information contained herein and assumes no responsibility or liability whatsoever for the use of the information contained herein. All information contained herein is subject to change without notice. Customers should obtain and verify the latest relevant information before placing orders for Qorvo products. The information contained herein or any use of such information does not grant, explicitly or implicitly, to any party any patent rights, licenses, or any other intellectual property rights, whether with regard to such information itself or anything described by such information. **THIS INFORMATION DOES NOT CONSTITUTE A WARRANTY WITH RESPECT TO THE PRODUCTS DESCRIBED HEREIN, AND QORVO HEREBY DISCLAIMS ANY AND ALL WARRANTIES WITH RESPECT TO SUCH PRODUCTS WHETHER EXPRESS OR IMPLIED BY LAW, COURSE OF DEALING, COURSE OF PERFORMANCE, USAGE OF TRADE OR OTHERWISE, INCLUDING THE IMPLIED WARRANTIES OF MERCHANTABILITY AND FITNESS FOR A PARTICULAR PURPOSE.**

Without limiting the generality of the foregoing, Qorvo products are not warranted or authorized for use as critical components in medical, life-saving, or life-sustaining applications, or other applications where a failure would reasonably be expected to cause severe personal injury or death.

Copyright 2016 © Qorvo, Inc. | Qorvo is a registered trademark of Qorvo, Inc.



Компания «ЭлектроПласт» предлагает заключение долгосрочных отношений при поставках импортных электронных компонентов на взаимовыгодных условиях!

Наши преимущества:

- Оперативные поставки широкого спектра электронных компонентов отечественного и импортного производства напрямую от производителей и с крупнейших мировых складов;
- Поставка более 17-ти миллионов наименований электронных компонентов;
- Поставка сложных, дефицитных, либо снятых с производства позиций;
- Оперативные сроки поставки под заказ (от 5 рабочих дней);
- Экспресс доставка в любую точку России;
- Техническая поддержка проекта, помощь в подборе аналогов, поставка прототипов;
- Система менеджмента качества сертифицирована по Международному стандарту ISO 9001;
- Лицензия ФСБ на осуществление работ с использованием сведений, составляющих государственную тайну;
- Поставка специализированных компонентов (Xilinx, Altera, Analog Devices, Intersil, Interpoint, Microsemi, Aeroflex, Peregrine, Syfer, Eurofarad, Texas Instrument, Miteq, Cobham, E2V, MA-COM, Hittite, Mini-Circuits, General Dynamics и др.);

Помимо этого, одним из направлений компании «ЭлектроПласт» является направление «Источники питания». Мы предлагаем Вам помощь Конструкторского отдела:

- Подбор оптимального решения, техническое обоснование при выборе компонента;
- Подбор аналогов;
- Консультации по применению компонента;
- Поставка образцов и прототипов;
- Техническая поддержка проекта;
- Защита от снятия компонента с производства.



Как с нами связаться

Телефон: 8 (812) 309 58 32 (многоканальный)

Факс: 8 (812) 320-02-42

Электронная почта: org@eplast1.ru

Адрес: 198099, г. Санкт-Петербург, ул. Калинина, дом 2, корпус 4, литера А.