



# TDF8530

I<sup>2</sup>C-bus controlled quad channel 45 W/2 Ω class-D power amplifier with full diagnostics

Rev. 3 — 20 October 2011

Product short data sheet

## 1. General description

---

The TDF8530 is a quad Bridge-Tied Load (BTL) car audio amplifier comprising an NDMOST-NDMOST output stage based on SOI BCDMOS technology. Low power dissipation enables the TDF8530 high-efficiency, class-D amplifier to be used with a smaller heat sink than those normally used with standard class-AB amplifiers.

The TDF8530 can operate in either non-I<sup>2</sup>C-bus mode or I<sup>2</sup>C-bus mode. When in I<sup>2</sup>C-bus mode, DC load detection results and fault conditions can be easily read back from the device. Up to 12 I<sup>2</sup>C-bus addresses can be selected depending on the value of the external resistors connected to pins ADS and MOD.

When pin ADS is short circuited to ground, the TDF8530 operates in non-I<sup>2</sup>C-bus mode. Switching between Operating mode and Mute mode in non-I<sup>2</sup>C-bus mode is only possible using pins EN and SEL\_MUTE.

## 2. Features and benefits

---

- High-efficiency
- Low quiescent current
- Operating voltage from 6 V to 24 V
- 4 Ω or 2 Ω capable BTL channels
- Fast-mode I<sup>2</sup>C-bus
- I<sup>2</sup>C-bus mode with 12 I<sup>2</sup>C-bus addresses or non-I<sup>2</sup>C-bus mode operation
- Clip detect selectable at 0.2 % or 10 % THD
- Independent short-circuit protection for each channel
- Advanced short-circuit protection for load, GND and supply
- Load dump protection to 50 V
- Thermal foldback and thermal protection
- DC offset protection
- Selectable AD or BD modulation
- Advanced clocking:
  - ◆ Switchable oscillator clock source: internal for Master mode or external for Slave mode
  - ◆ Spread spectrum mode
  - ◆ Phase staggering
  - ◆ Frequency hopping
- No 'pop noise' caused by DC output offset voltage
- I<sup>2</sup>C-bus mode:



- ◆ Load diagnostics
  - Speaker load, open load and shorted load
  - Amplifier output to ground and to supply shorts
  - Tweeter detection
- ◆ Thermal pre-warning diagnostic level setting
- ◆ Identification of activated protections or warnings
- ◆ Selectable diagnostic information available using DIAG pin
- Qualified in accordance with AEC-Q100

### 3. Applications

- Car audio
- Audio entertainment systems

### 4. Quick reference data

Table 1. Quick reference data

Symbol	Parameter	Conditions	Min	Typ	Max	Unit
<b>General; V<sub>P</sub> = 14.4 V</b>						
V <sub>P</sub>	supply voltage		6	14.4	24	V
I <sub>P</sub>	supply current	off state; V <sub>EN</sub> < 0.8 V	-	2	10	μA
I <sub>q</sub>	quiescent current	no load, snubbers and output filter connected	-	185	200	mA
<b>Quad BTL channel; V<sub>P</sub> = 14.4 V</b>						
P <sub>o</sub>	output power	R <sub>L</sub> = 4 Ω; THD = 10 %	24	26	-	W
		R <sub>L</sub> = 2 Ω; THD = 10 %	39	45	-	W
<b>Quad BTL channel; V<sub>P</sub> = 24 V</b>						
P <sub>o</sub>	output power	R <sub>L</sub> = 4 Ω; THD = 10 %	-	70	-	W
		R <sub>L</sub> = 2 Ω; THD = 10 %	-	100	-	W

### 5. Ordering information

Table 2. Ordering information

Type number	Package		Version
	Name	Description	
TDF8530TH	HSOP44	plastic, heatsink small outline package; 44 leads; low stand-off height	SOT1131-1

6. Block diagram

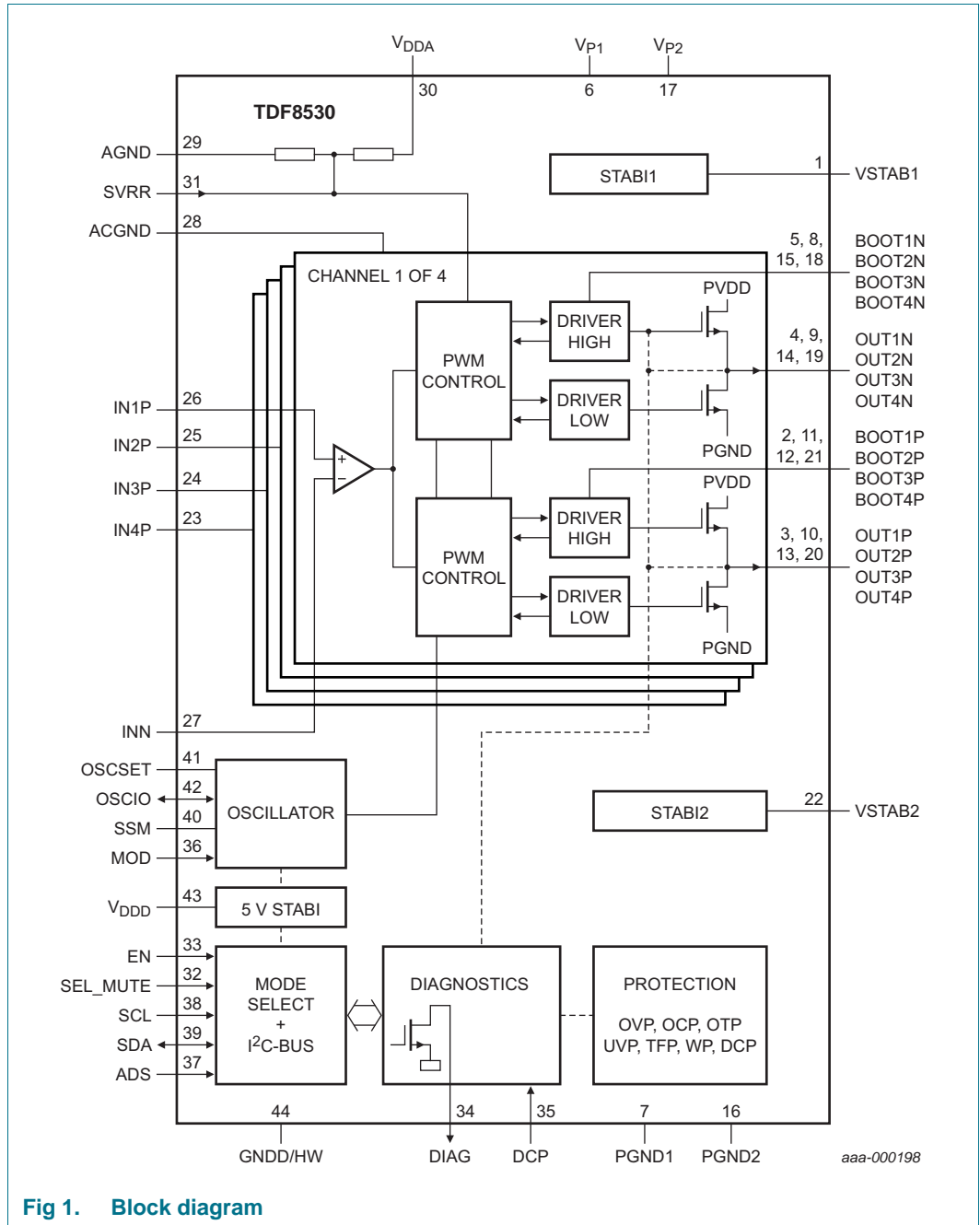

Fig 1. Block diagram

## 7. Pinning information

### 7.1 Pinning

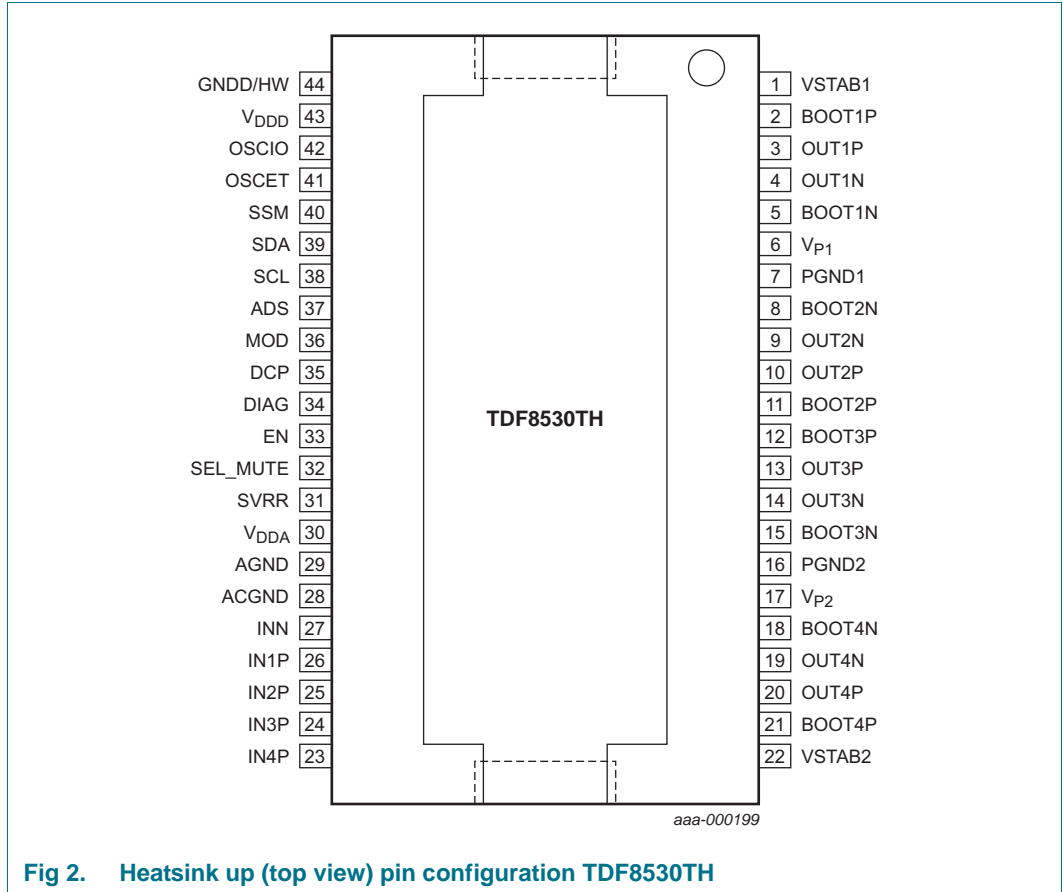

Fig 2. Heatsink up (top view) pin configuration TDF8530TH

### 7.2 Pin description

Table 3. Pin description

Symbol	Pin	Type <sup>[1]</sup>	Description
VSTAB1	1		decoupling internal stabilizer 1 for DMOST drivers
BOOT1P	2		bootstrap capacitor for channel 1 positive
OUT1P	3	O	channel 1 positive PWM output
OUT1N	4	O	channel 1 negative PWM output
BOOT1N	5		bootstrap capacitor for channel 1 negative
V <sub>P1</sub>	6	P	channel 1 power supply voltage
PGND1	7	G	channel 1 power ground
BOOT2N	8		bootstrap capacitor for channel 2 negative
OUT2N	9	O	channel 2 negative PWM output
OUT2P	10	O	channel 2 positive PWM output
BOOT2P	11		bootstrap capacitor for channel 2 positive
BOOT3P	12		bootstrap capacitor for channel 3 positive

Table 3. Pin description ...continued

Symbol	Pin	Type <sup>[1]</sup>	Description
OUT3P	13	O	channel 3 positive PWM output
OUT3N	14	O	channel 3 negative PWM output
BOOT3N	15		bootstrap capacitor for channel 3 negative
PGND2	16	G	channel 2 power ground
V <sub>P2</sub>	17	P	channel 2 power supply voltage
BOOT4N	18		bootstrap capacitor for channel 4 negative
OUT4N	19	O	channel 4 negative PWM output
OUT4P	20	O	channel 4 positive PWM output
BOOT4P	21		bootstrap capacitor for channel 4 positive
VSTAB2	22		decoupling internal stabilizer 2 for DMOST drivers
IN4P	23	I	channel 4 positive audio input
IN3P	24	I	channel 3 positive audio input
IN2P	25	I	channel 2 positive audio input
IN1P	26	I	channel 1 positive audio input
INN	27	I	common negative audio input
ACGND	28	I	decoupling for input reference voltage
AGND	29	G	analog supply ground
V <sub>DDA</sub>	30	P	analog supply voltage
SVRR	31	I	decoupling for internal half supply reference voltage
SEL_MUTE	32	I	select mute or unmute
EN	33	I	enable input: non-I <sup>2</sup> C-bus mode: switch between off and Mute mode I <sup>2</sup> C-bus mode: off and Standby mode
DIAG	34	O	diagnostic output; open-drain
DCP	35	I	DC protection input for the filtered output voltages
MOD	36	I	modulation mode and phase shift select
ADS	37	I	non-I <sup>2</sup> C-bus mode: connected to ground I <sup>2</sup> C-bus mode: selection and address selection pin
SCL	38	I	I <sup>2</sup> C-bus clock input
SDA	39	I/O	I <sup>2</sup> C-bus data input and output
SSM	40		master setting: Spread spectrum mode frequency slave setting: phase lock operation
OSCSET	41		master/slave oscillator setting master only setting: set internal oscillator frequency
OSCIO	42	I/O	external oscillator slave setting: input internal oscillator master setting: output
V <sub>DDD</sub>	43		decoupling of the internal 5 V logic supply
GNDD/HW	44	G	ground digital supply voltage and handle wafer connection

[1] I = input, O = output, I/O = input/output, G = ground and P = power supply.

[2] In this data sheet supply voltage V<sub>P</sub> describes V<sub>P1</sub>, V<sub>P2</sub> and V<sub>DDA</sub>.

## 8. Functional description

### 8.1 Master and slave mode selection

In a master and slave configuration, multiple TDF8530 devices are daisy-chained together in one audio application with a single device providing the clock frequency signal for all other devices. In this situation, it is recommended that the oscillators of all devices are synchronized for optimum EMI behavior as follows:

All OSCIO pins are connected together and one TDF8530 in the application is configured as the clock-master. All other TDF8530 devices are configured as clock-slaves.

- The clock-master pin OSCIO is configured as the oscillator output. When a resistor ( $R_{osc}$ ) is connected between pins OSCSET and AGND, the TDF8530 is in Master mode.
- The clock-slave pins OSCIO are configured as the oscillator inputs. When pin OSCSET is directly connected to pin AGND, the TDF8530 is in Slave mode.

See [Table 4](#) for all oscillator modes. IB3[D2] = 0 in non-I<sup>2</sup>C-bus mode.

**Table 4. Oscillator modes**

OSCSET pin	OSCIO pin	SSM pin	IB3[D2]	Oscillator modes
$R_{osc} > 22\text{ k}\Omega$	output	C <sub>SSM</sub> to pin AGND	0	master, spread spectrum <sup>[1]</sup>
			1	master, spread spectrum <sup>[2]</sup>
		shorted to pin AGND	0	master, no spread spectrum <sup>[1]</sup>
			1	master, no spread spectrum <sup>[2]</sup>
$R_{osc} = 0\ \Omega$	input	C <sub>PLL</sub> + R <sub>PLL</sub> to pin AGND	0	slave, PLL enabled <sup>[1]</sup>
			1	slave, PLL enabled <sup>[2]</sup>
		shorted to pin AGND	0	slave, PLL disabled <sup>[1]</sup> no $\frac{1}{2}\pi$ phase staggering
			1	slave, PLL disabled <sup>[2]</sup>

[1]  $f_{OSCIO} = f_{osc}$ .

[2]  $f_{OSCIO} = 2 \times f_{osc}$ .

### 8.2 Operation mode selection

Pin MOD is used to select specific operating modes. The resistor ( $R_{MOD}$ ) connected between pins MOD and AGND together with the non-I<sup>2</sup>C-bus/I<sup>2</sup>C-bus mode determine the operating mode (see [Table 5](#)). This in turn is determined by the resistor value connected between pins ADS and AGND.

In non-I<sup>2</sup>C-bus mode, pin MOD is used to select:

- AD or BD modulation (see [Section 8.2.1](#)).
- $\frac{2}{8}\pi$  phase shift when oscillator is used in Slave mode (see [Section 8.2.2](#)).

In I<sup>2</sup>C-bus mode, pin MOD can only select the I<sup>2</sup>C-bus address range. The modulation mode and phase shift are programmed using I<sup>2</sup>C-bus commands.

**Table 5. Operation mode selection with the MOD pin**

R <sub>MOD</sub> (kΩ)	Non-I <sup>2</sup> C-bus mode <sup>[1]</sup>
0 (short to AGND)	AD modulation: no phase shift in Slave mode
6.8	BD modulation: no phase shift in Slave mode
33	AD modulation: $\frac{2}{8} \pi$ phase shift in Slave mode
100	BD modulation: $\frac{2}{8} \pi$ phase shift in Slave mode

[1] R<sub>ADS</sub> = 0 Ω; pin ADS is short circuited to pin AGND.

**8.2.1 Modulation mode**

In non-I<sup>2</sup>C-bus mode, pin MOD is used to select either AD or BD modulation mode (see [Table 5](#)). In I<sup>2</sup>C-bus mode, the modulation mode is selected using I<sup>2</sup>C-bus command IB3[D0].

- AD modulation mode: the bridge halves switch in opposite phase.
- BD modulation mode: the bridge halves switch in phase.

[Figure 4](#) and [Figure 5](#) show simplified representations of AD and BD modulation.

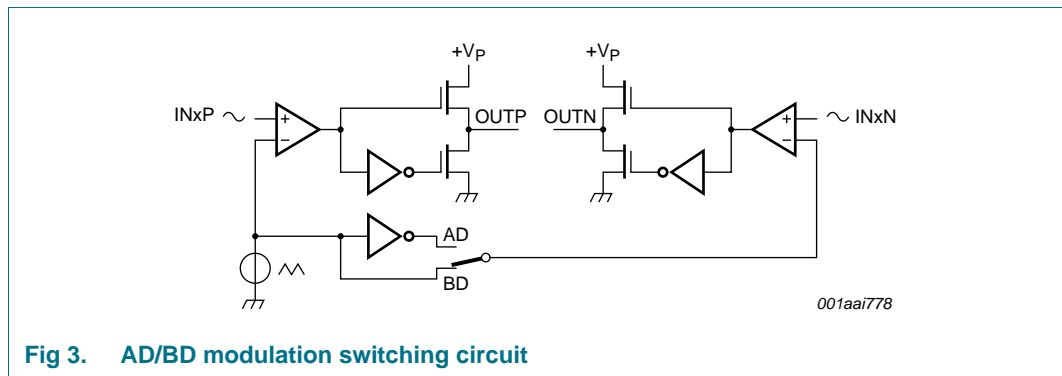

**Fig 3. AD/BD modulation switching circuit**

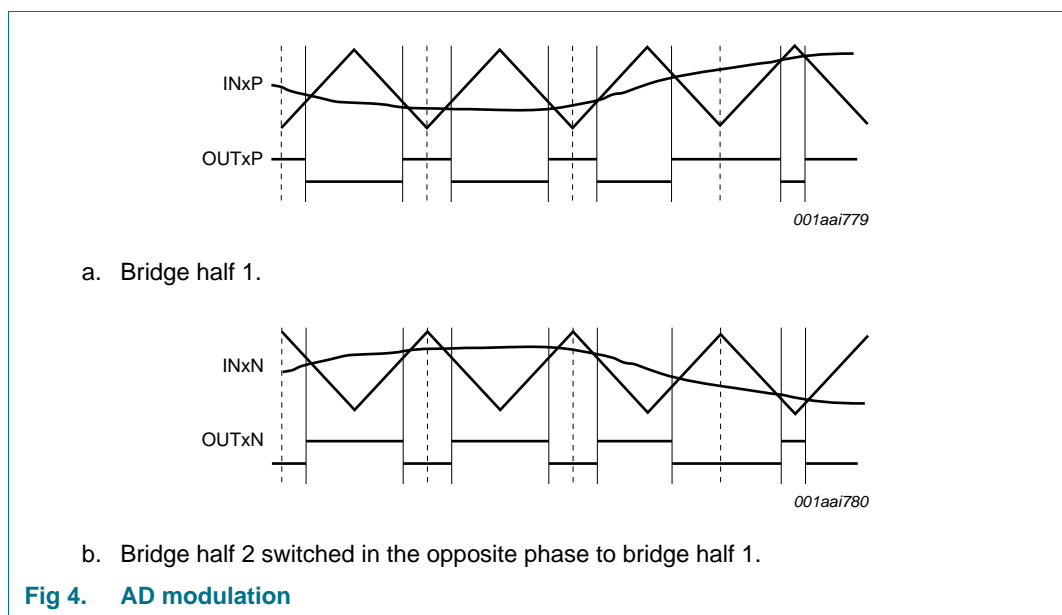

**Fig 4. AD modulation**

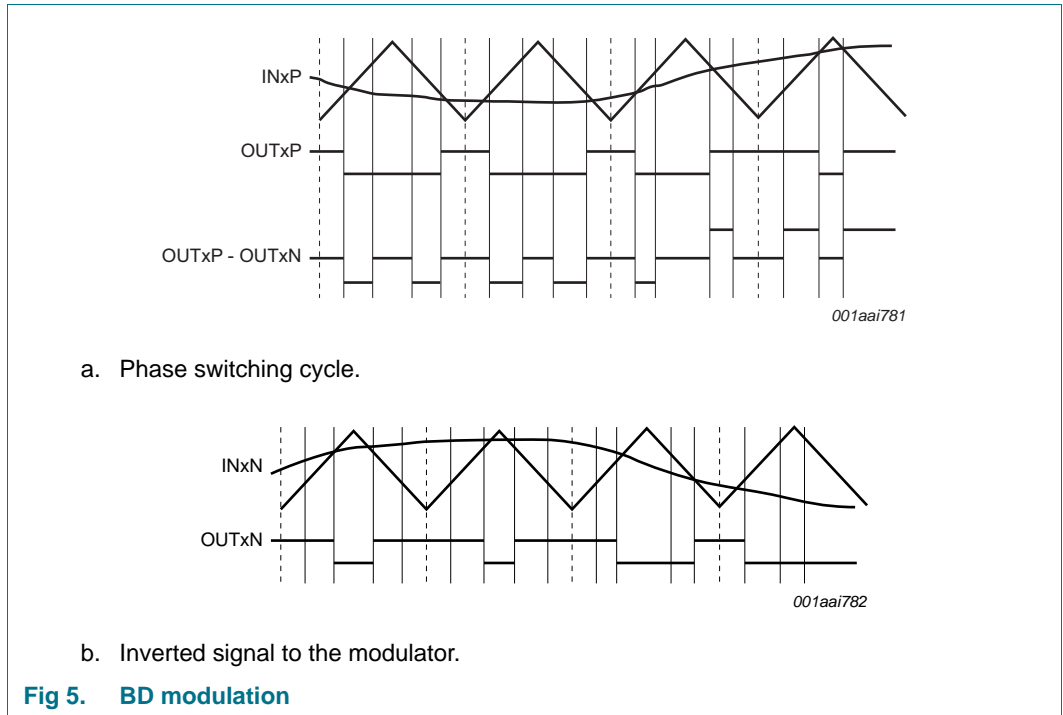

### 8.2.2 Phase staggering (Slave mode)

In Slave mode with phase lock operation enabled, a phase shift with respect to the incoming clock signal can be selected to distribute the switching moments over time in multi-amplifier applications. In non-I<sup>2</sup>C-bus mode,  $\frac{2}{8} \pi$  phase shift can be programmed using pin MOD. In I<sup>2</sup>C-bus mode, three different phase shifts ( $\frac{1}{8} \pi$ ,  $\frac{2}{8} \pi$ ,  $\frac{3}{8} \pi$ ) can be selected using the I<sup>2</sup>C-bus bits (IB4[D2:D3]). See [Table 5](#) for selection of the phase shift in non-I<sup>2</sup>C-bus mode with pin MOD.

By default there is a  $\frac{1}{2} \pi$  phase staggering between channels 1 and 2 and channels 3 and 4 of the TDF8530 independent of Master or Slave mode. This  $\frac{1}{2} \pi$  phase staggering can be disabled using the I<sup>2</sup>C-bus bit IB4[D4] resulting in all channels switching at the same time.

[Figure 6](#) shows an example of the use of  $\frac{2}{8} \pi$  phase shift with BD modulation.



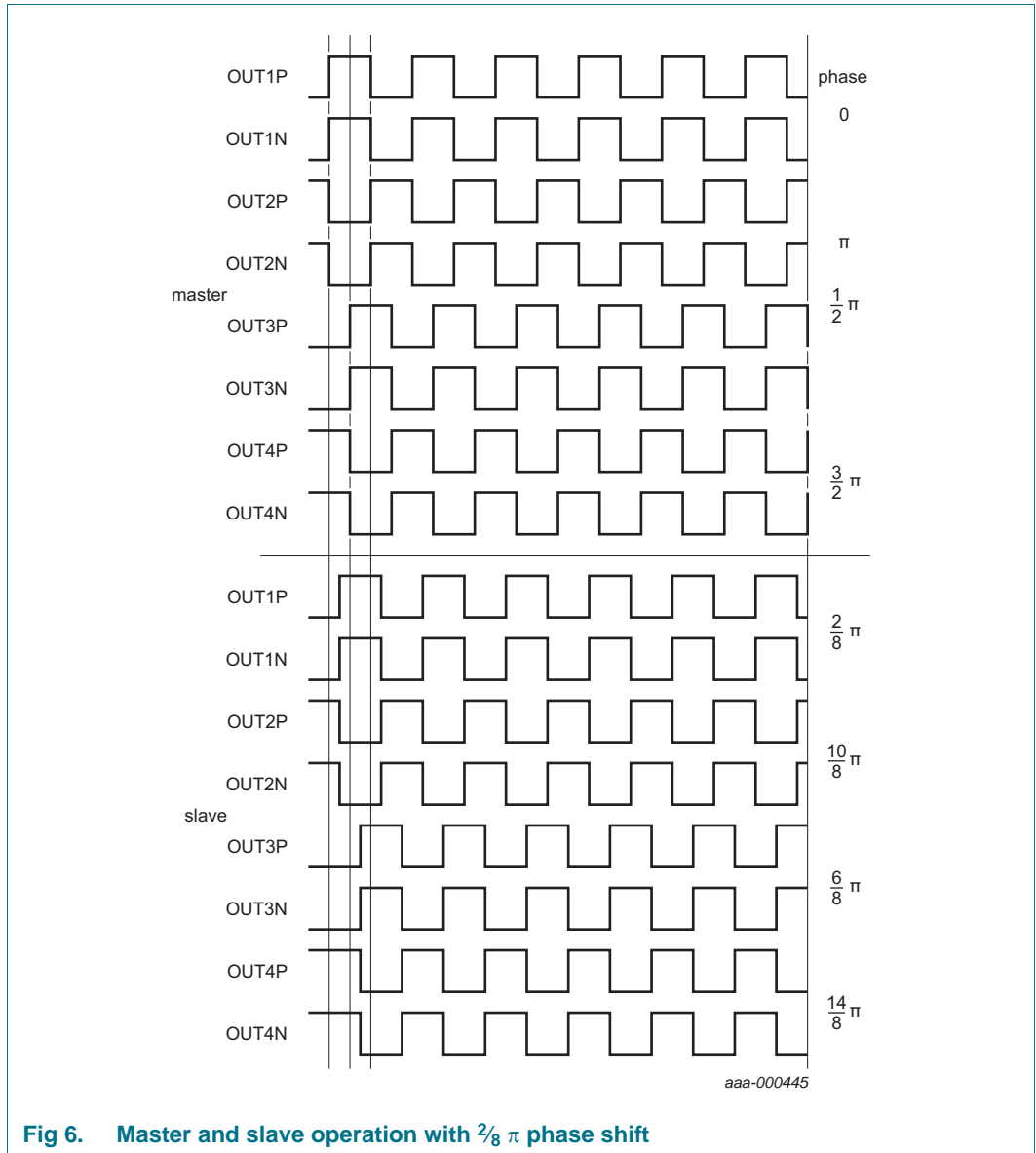

Fig 6. Master and slave operation with  $\frac{2}{8} \pi$  phase shift

### 8.3 Protection

The TDF8530 includes a range of built-in protection functions. All protections are asynchronous and do not need an (external) clock signal at pin OSCIO to be operational. How the TDF8530 manages the various possible fault conditions for each protection is described in the following sections:

Table 6. Overview of protection types

Protection type	Reference
Thermal foldback	<a href="#">Section 8.3.1</a>
Overtemperature	<a href="#">Section 8.3.2</a>
Overcurrent	<a href="#">Section 8.3.3</a>
Window	<a href="#">Section 8.3.4</a>

Table 6. Overview of protection types ...continued

Protection type	Reference
DC Offset	<a href="#">Section 8.3.5</a>
Undervoltage	<a href="#">Section 8.3.6</a>
Overvoltage	<a href="#">Section 8.3.6</a>

### 8.3.1 Thermal foldback

The TDF8530 has a built-in Thermal Foldback Protection (TFP) which is tripped when the average junction temperature exceeds the threshold level. TFP decreases amplifier gain such that the combination of power dissipation and  $R_{th(j-a)}$  create a junction temperature around the threshold level. The device will not completely switch off but remains operational at the lower output power levels. If the average junction temperature continues to increase, a second built-in temperature protection threshold level shuts down the amplifier completely.

### 8.3.2 Overtemperature protection

If the average junction temperature ( $T_j$ ) > 160 °C, OverTemperature Protection (OTP) is tripped and the power stages shut down immediately.

### 8.3.3 Overcurrent protection

OverCurrent Protection (OCP) is tripped when the output current exceeds the threshold. OCP regulates the output voltage such that the maximum output current is limited. The amplifier outputs keep switching and the amplifier is NOT shutdown completely. This is called current limiting.

OCP also detects when the loudspeaker terminals are short circuited or one of the amplifier's demodulated outputs is short circuited to one of the supply lines. In either case, the shorted channel(s) are switched off.

The amplifier can distinguish between loudspeaker impedance drops and a low-ohmic short across the load or one of the supply lines. This impedance threshold depends on the supply voltage used. When a short is made across the load causing the impedance to drop below the threshold level, the shorted channel(s) are switched off. They try to restart every 50 ms. If the short circuit condition is still present after 50 ms, the cycle repeats. The average power dissipation will be low because of this reduced duty cycle.

When a channel is switched off due to a short circuit on one of the supply lines, Window Protection (WP) is activated. WP ensures that the amplifier does not start up after 50 ms until the supply line short circuit is removed.

### 8.3.4 Window protection

Window Protection (WP) checks the PWM output voltage before switching from Standby mode to Mute mode (with both outputs switching) and is activated as follows:

- During the start-up sequence:
  - When the TDF8530 is switched from standby to mute ( $t_{d(stb-mute)}$ ). When a short circuit on one of the output terminals (to  $V_P$  or GND) is detected, the start-up procedure for that channel is interrupted and the TDF8530 waits for open circuit outputs. No large currents flow in the event of a short circuit to the supply lines because the check is performed before the power stages are enabled.

- During operation:
  - A short circuit to one of the supply lines trips OCP causing the amplifier channel to shut down. After 50 ms the amplifier channel restarts and WP is activated. However, the corresponding amplifier channel will not start up until the supply line short circuit has been removed.

### 8.3.5 DC offset protection

DC Protection (DCP) is activated (using IB1[D6] or IB2[D6]) when the DC content in the demodulated output voltage exceeds a set threshold (typically 2 V). DCP is active in both Mute mode and Operating mode. False triggering of the DCP by low frequencies in the audio signal is prevented by use of an external capacitor between pin DCP and pin AGND to generate a cut-off frequency. Connecting pin DCP to pin AGND disables DCP in both I<sup>2</sup>C-bus and non-I<sup>2</sup>C-bus modes. The DCP is always disabled when the supply voltage on pin V<sub>DDA</sub> drops below 8 V.

### 8.3.6 Supply voltage protection

UnderVoltage Protection (UVP) is activated when the supply voltage drops below the UVP threshold. UVP triggers the UVP circuit causing the system to first mute and then stop switching. The SVRR and SEL\_MUTE pin capacitors will discharge. The information on the MOD and ADS pins is latched while UVP is active. When the supply voltage rises above the UVP threshold level, the system restarts. The UVP threshold is set at 6 V minimum supply by default but can be changed to 8 V minimum supply using bit IB4[D7].

OverVoltage Protection (OVP) is activated when the supply voltage exceeds the OVP threshold. The OVP (or load dump) circuit is activated and the power stages are shut down. The SVRR and SEL\_MUTE pin capacitors will discharge. When the supply voltage drops below the OVP threshold level the system restarts.

## 8.4 Diagnostic output

### 8.4.1 Diagnostic table

The diagnostic information for I<sup>2</sup>C-bus mode and non-I<sup>2</sup>C-bus mode is shown in [Table 7](#). The instruction bitmap and data bytes are described in [Table 9](#) and [Table 11](#).

Pin DIAG has an open-drain output which must have an external pull-up resistor connected to an external voltage. Pin DIAG can show both fixed and I<sup>2</sup>C-bus selectable information.

Pin DIAG goes LOW when a short-circuit to one of the amplifier outputs occurs. The microprocessor reads the failure information using the I<sup>2</sup>C-bus. The I<sup>2</sup>C-bus bits are set for a short-circuit. These bits can be reset with the I<sup>2</sup>C-bus read command.

Even after the short circuit has been removed, the microprocessor knows what was wrong after reading the I<sup>2</sup>C-bus. Old information is read when a single I<sup>2</sup>C-bus read command is used. To read the current information, two read commands must be sent, one after another.

When selected, pin DIAG gives the current diagnostic information. Pin DIAG is released instantly when the failure is removed, independent of the I<sup>2</sup>C-bus latches.

In non-I<sup>2</sup>C-bus mode, pins SCL and SDA behave as open drain outputs showing clip detection diagnostics. Pin SCL shows clip diagnostics from channels 1 and 2. Pin SDA shows clip diagnostics from channels 3 and 4.

**Table 7. Available data on pins DIAG, SCL and SDA**

Diagnostic	I <sup>2</sup> C-bus mode	Non-I <sup>2</sup> C-bus mode		
	Pin DIAG	Pin DIAG	Pin SCL	Pin SDA
Power-on reset	yes	yes	no	no
UVP or OVP	yes	yes	no	no
Clip detection	selectable	no	channels 1 and 2	channels 3 and 4
Temperature pre-warning	selectable	yes	no	no
OCP/WP	yes	yes	no	no
DCP	selectable	yes	no	no
OTP	yes	yes	no	no
Watchdog alarm	yes	yes	no	no
AC load detection; see <a href="#">Section 8.4.2.2</a>	selectable	no	no	no

When OCP is triggered, the open-drain DIAG output is activated. The diagnostic output signal during different short circuit conditions is illustrated in [Figure 7](#).

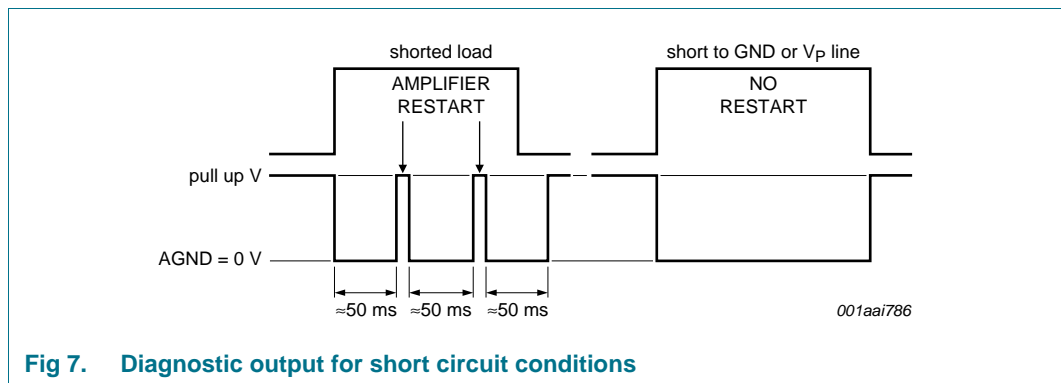

**Fig 7. Diagnostic output for short circuit conditions**

## 8.4.2 Load identification (I<sup>2</sup>C-bus mode only)

### 8.4.2.1 DC load detection

DC load detection is only available in I<sup>2</sup>C-bus mode and is controlled using bit IB2[D2]. The default setting is logic 0 for bit IB2[D2] which disables DC load detection. DC load detection is enabled when bit IB2[D2] = 1. Load detection takes place before the SVRR capacitor is charged and before the class-D amplifier output stage starts switching. The start-up time from Standby mode to Mute mode is increased by  $t_{det(DCload)}$  (see [Figure 8](#)).

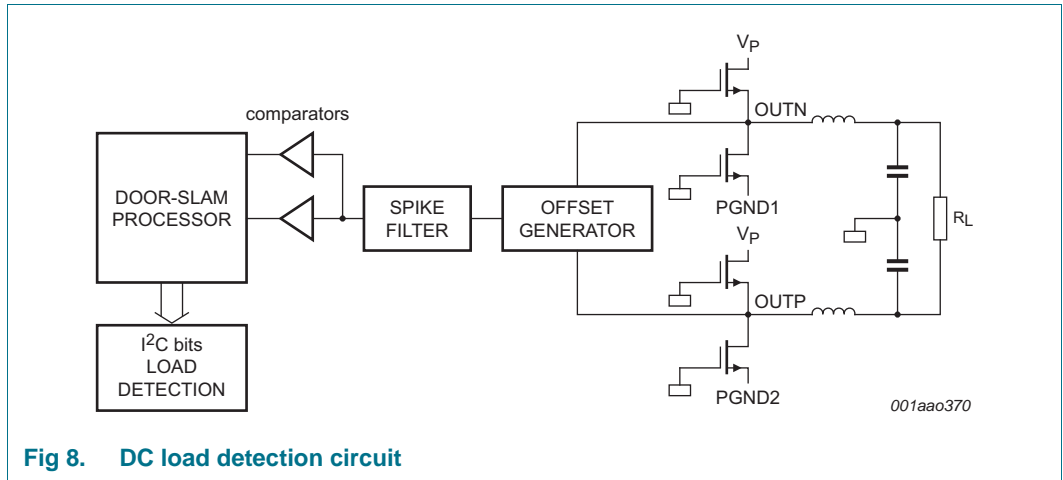

Fig 8. DC load detection circuit

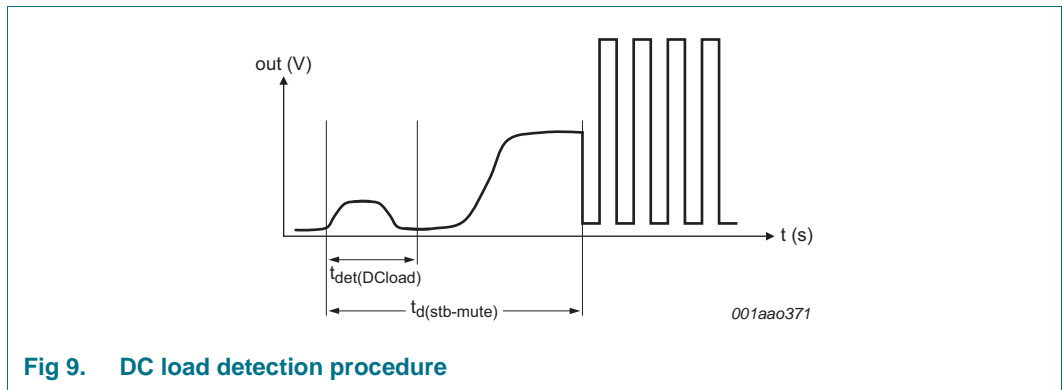

Fig 9. DC load detection procedure

An inaudible current test pulse is created between the amplifier outputs. The external capacitor connected to pin SEL\_MUTE is used for timing. Load diagnostics based on the voltage difference between pins OUTxP and OUTxN are shown in [Figure 8](#) and [Figure 9](#)

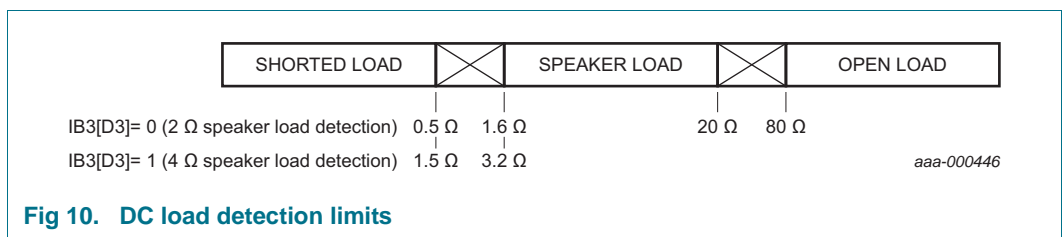

Fig 10. DC load detection limits

DC Load detection has built in spike filtering and a door-slam processor to remove disturbances caused by switching relays in the wiring harness, EMI or the closing of a car door. Reliable load detection is performed in one diagnostic cycle with these filter techniques.

**8.4.2.2 AC load detection (tweeter detection)**

AC load detection is only available in I<sup>2</sup>C-bus mode and is controlled using bit IB1[D2]. The default setting for bit IB1[D2] = 0 disables AC load detection. When AC load detection is enabled, the average amplifier load current is measured and compared with a reference level. Pin DIAG is activated when this threshold is reached. Using this information, AC load detection can be performed using a predetermined input signal frequency and level.

The frequency and signal level should be chosen so that the average load current exceeds the programmed current threshold when the AC coupled load (tweeter) is present.

### 8.4.3 Clip detection

Clip detection gives information for clip levels exceeding a threshold defined as the THD level of a sinusoidal output signal. The default value of this threshold is set at 0.2 %, but can be set to 10 % using  $IB3[D4] = 1$ .

In non-I<sup>2</sup>C-bus mode pins SCL and SDA behave as open drain outputs showing THD = 0.2 % clip detection diagnostics. Pin SCL shows clip diagnostics from channels 1 and 2. Pin SDA shows clip diagnostics from channels 3 and 4.

In I<sup>2</sup>C-bus mode pin DIAG is used as output of the clip detection circuitry for all channels. Setting bit  $IBx[D5]$  to logic 0 in I<sup>2</sup>C-bus mode defines which channel reports clip information on the DIAG pin. Clip detection is disabled when the AC load detection is active.

### 8.4.4 Start-up and shutdown sequence

To prevent switch on or switch off 'pop noises', a capacitor ( $C_{SVRR}$ ) connected to pin SVRR is used to smooth start-up and shutdown. During start-up and shutdown, the output voltage tracks the voltage on pin SVRR. Increasing  $C_{SVRR}$  results in a longer start-up and shutdown time. Enhanced pop noise performance is achieved by muting the amplifier until the SVRR voltage reaches its final value and the outputs start switching. The value of capacitor  $C_{ON}$  connected to pin SEL\_MUTE determines the unmute and mute timing. The voltage on pin SEL\_MUTE determines the amplifier gain. Increasing  $C_{ON}$  increases the unmute and mute times. In addition, a larger  $C_{ON}$  value increases the DC load detection cycle time.

When the amplifier is switched off with an I<sup>2</sup>C-bus command or by pulling pin EN LOW, the amplifier is first muted and then capacitor ( $C_{SVRR}$ ) is discharged.

In Slave mode, the device enters the off state immediately after capacitor ( $C_{SVRR}$ ) is discharged. In Master mode, the clock is kept active by an additional delay ( $t_d^{(2)}$ ) of approximately 50 ms to allow slave devices to enter the off state.

A clock signal is needed during the start-up and shutdown sequence. When an external clock is connected to pin OSCIO (in Slave mode), the clock must remain active during the shutdown sequence for delay ( $t_d^{(1)}$ ) to ensure that the slaved TDF8530 devices are able to enter the off state. A watchdog is added to protect against clock failure.

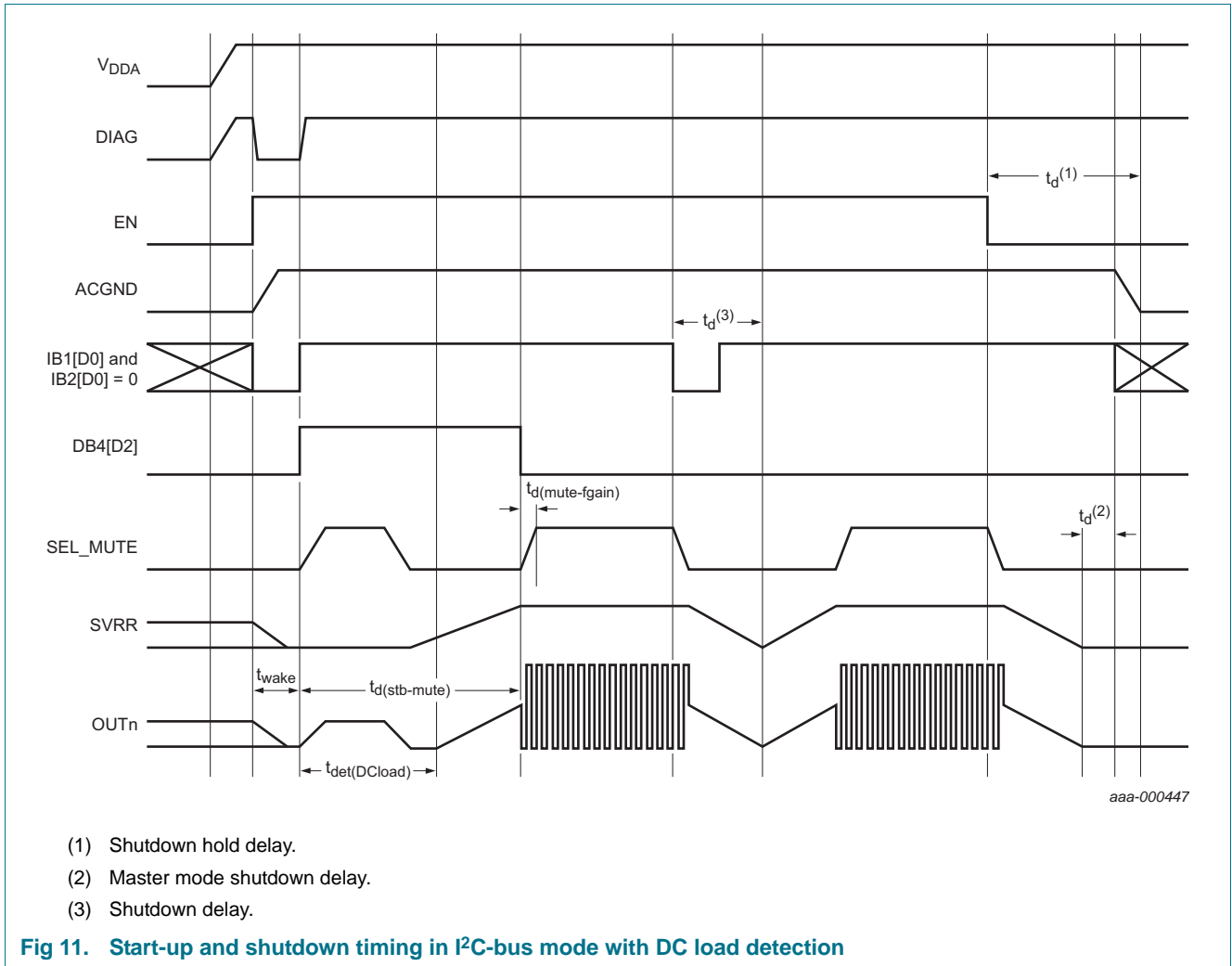

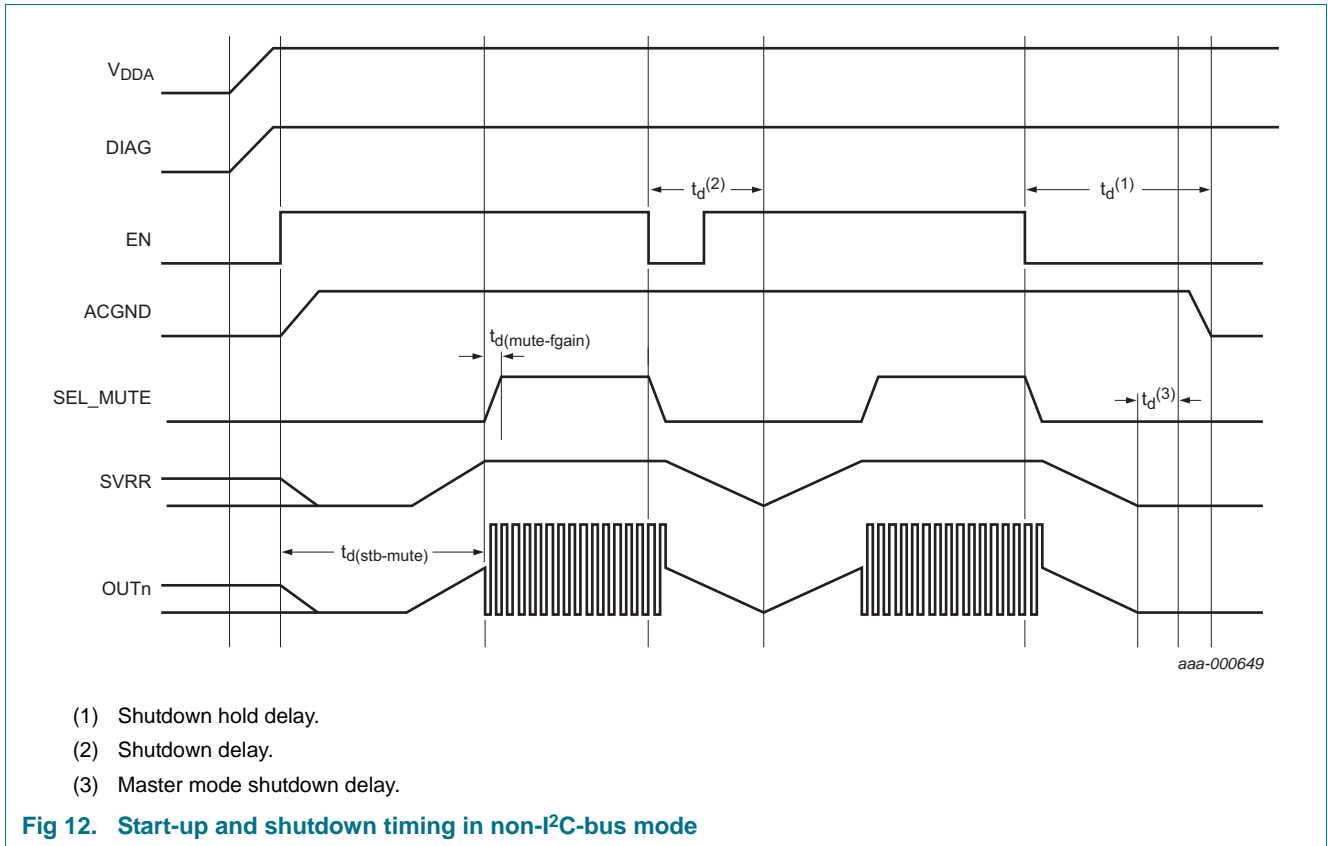

Fig 12. Start-up and shutdown timing in non-I<sup>2</sup>C-bus mode

## 9. I<sup>2</sup>C-bus specification

TDF8530 address with hardware address select.

Table 8. I<sup>2</sup>C-bus write address selection using pins MOD and ADS

R <sub>ADS</sub> (kΩ)	R <sub>MOD</sub> (kΩ)				R/W
	0 <sup>[1]</sup>	6.8	33	100	
100	44h	54h	64h	74h	1 = Read from TDF8530
33	42h	52h	62h	72h	0 = Write to TDF8530
6.8	40h	50h	60h	70h	
0 <sup>[1]</sup>	non-I <sup>2</sup> C-bus mode select				

[1] Short circuited to ground.



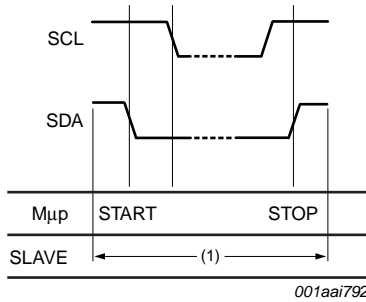

- (1) When SCL is HIGH, SDA changes to form the start or stop condition.

Fig 13. I<sup>2</sup>C-bus start and stop conditions

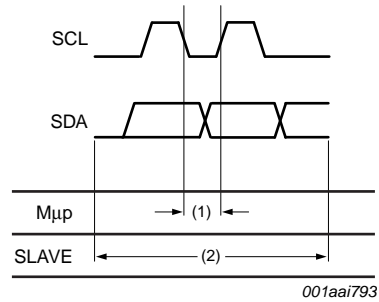

- (1) SDA is allowed to change.
- (2) All data bits must be valid on the positive edges of SCL.

Fig 14. Data bits sent from Master microprocessor (Mµp)

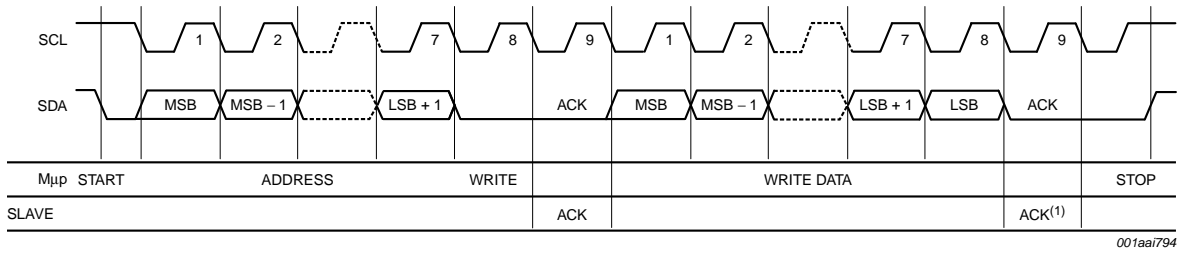

- (1) To stop the transfer after the last acknowledge a stop condition must be generated.

Fig 15. I<sup>2</sup>C-bus write

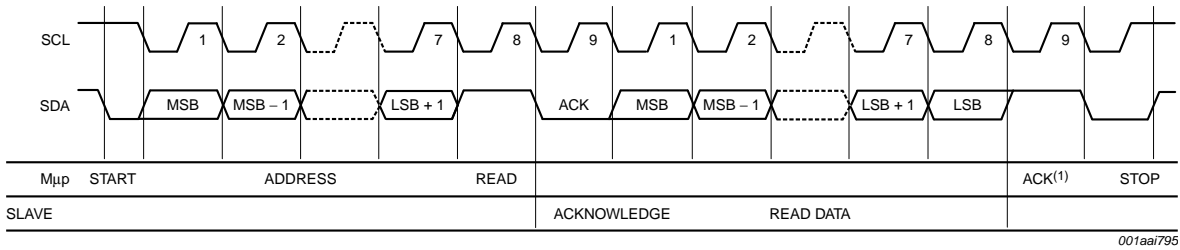

- (1) To stop the transfer, the last byte must not be acknowledged (SDA is HIGH) and a stop condition must be generated.

Fig 16. I<sup>2</sup>C-bus read

## 9.1 Instruction bytes

If R/W bit = 0, the TDF8530 expects four instruction bytes: IB1, IB2, IB3, and IB4. Reserved instruction bits must be programmed to zero. After a power-on reset, all instruction bits are set to zero.

**Table 9. Instruction byte descriptions**

Bit	Value	Description			
		Instruction byte IB1	Instruction byte IB2	Instruction byte IB3	Instruction byte IB4
D7	0	offset detection on pin DIAG	offset protection on	latch information on pins ADS and MOD when the amplifier starts switching	undervoltage protection threshold for 6 V minimum supply
	1	no offset detection on pin DIAG	offset protection off	latch information on pins ADS and MOD	undervoltage protection threshold for 8 V minimum supply
D6	0	channel 1 offset monitoring on	channel 2 offset monitoring on	channel 3 offset monitoring on	channel 4 offset monitoring on
	1	channel 1 offset monitoring off	channel 2 offset monitoring off	channel 3 offset monitoring off	channel 4 offset monitoring off
D5	0	channel 1 clip detect on pin DIAG	channel 2 clip detect on pin DIAG	channel 3 clip detect on pin DIAG	channel 4 clip detect on pin DIAG
	1	channel 1 no clip detect on pin DIAG	channel 2 no clip detect on pin DIAG	channel 3 no clip detect on pin DIAG	channel 4 no clip detect on pin DIAG
D4	0	disable frequency hopping	thermal pre-warning on pin DIAG	clip detection at THD = 0.2 %	enable phase staggering between channels 1 and 2, and 3 and 4
	1	enable frequency hopping <sup>[1]</sup>	no thermal pre-warning on pin DIAG	clip detection at THD = 10 %	no phase staggering between channels 1 and 2, and 3 and 4
D3	0	oscillator frequency as set with R <sub>osc</sub> – 10 %	temperature pre-warning at 140 °C	1 Ω detection level for shorted load detection	phase shift in slave mode with respect to master clock, oscillator phase shift bits IB4[D3] to IB4[D2] <sup>[2]</sup>
	1	oscillator frequency as set with R <sub>osc</sub> + 10 %	temperature pre-warning at 120 °C	2 Ω detection level for shorted load detection	
D2	0	disable AC-load detection on pin DIAG	DC-load detection disabled	f <sub>OSCIO</sub> = f <sub>osc</sub> <sup>[3]</sup>	
	1	enable AC-load detection on pin DIAG	DC-load detection enabled	f <sub>OSCIO</sub> = 2 × f <sub>osc</sub> <sup>[3]</sup>	
D1	0	channel 1 enabled	channel 2 enabled	channel 3 enabled	channel 4 enabled
	1	channel 1 disabled	channel 2 disabled	channel 3 disabled	channel 4 disabled
D0	0	TDF8530 in Standby mode	all channels operating	AD modulation	oscillator watchdog enabled during amplifier shut down only
	1	TDF8530 in Mute or Operating modes <sup>[4]</sup>	all channels muted	BD modulation	oscillator watchdog enabled

[1] See IB1[D3].

[2] See [Table 10 “Phase shift bit settings”](#) for information on IB4[D3] to IB4[D2].

[3] See [Table 4 “Oscillator modes”](#)

[4] See IB2[D0].

Table 10. Phase shift bit settings

D3	D2	Phase
0	0	0
0	1	$\frac{1}{8} \pi$
1	0	$\frac{2}{8} \pi$
1	1	$\frac{3}{8} \pi$

## 9.2 Data bytes

If R/W = 1, the TDF8530 sends four data bytes to the microprocessor (DB1, DB2, DB3 and DB4). All short diagnostic and offset protection bits and bits OTP, UVP and OVP are latched. In addition, all bits are reset after a read operation except the DC load detection bits (DBx[D3,D4], DB1[D6]). The default setting for all bits is logic 0.

Table 11. Description of data bytes

Bit	Value	DB1 channel 1	DB2 channel 2	DB3 channel 3	DB4 channel 4
D7	0	at least 1 instruction bit set to logic 1	below maximum temperature	reserved	reserved
	1	all instruction bits are set to logic 0	maximum temperature protection occurred	-	-
D6	0	invalid DC load data	no temperature warning	reserved	reserved
	1	valid DC load data	temperature pre-warning active	-	-
D5	0	no overvoltage	no undervoltage	reserved	reserved
	1	overvoltage protection occurred	undervoltage protection occurred	-	-
D4	0	speaker load channel 1	speaker load channel 2	speaker load channel 3	speaker load channel 4
	1	open load channel 1	open load channel 2	open load channel 3	open load channel 4
D3	0	no shorted load channel 1	no shorted load channel 2	no shorted load channel 3	no shorted load channel 4
	1	shorted load channel 1	shorted load channel 2	shorted load channel 3	shorted load channel 4
D2	0	no offset	PLL not locked (slave mode)	clock running	start up diagnostics finished
	1	offset detected on channels selected with IBx[D6]	PLL locked (slave mode)	clock failure	start up diagnostics in progress
D1	0	no short to V <sub>P</sub> channel 1	no short to V <sub>P</sub> channel 2	no short to V <sub>P</sub> channel 3	no short to V <sub>P</sub> channel 4
	1	short to V <sub>P</sub> channel 1	short to V <sub>P</sub> channel 2	short to V <sub>P</sub> channel 3	short to V <sub>P</sub> channel 4
D0	0	no short to ground channel 1	no short to ground channel 2	no short to ground channel 3	no short to ground channel 4
	1	short to ground channel 1	short to ground channel 2	short to ground channel 3	short to ground channel 4

Data byte DB1[D7] indicates whether the instruction bits have been set to logic 0. In principle, DB1[D7] is set after a POR or when all the instruction bits are programmed to logic 0. Pin DIAG is driven LOW when bit DB1[D7] = 1.

## 10. Limiting values

**Table 12. Limiting values**
*In accordance with the Absolute Maximum Rating System (IEC 60134).*

Symbol	Parameter	Conditions	Min	Max	Unit
V <sub>P</sub>	supply voltage	Operating mode	-	29	V
		off state	[1] -1	+50	V
		load dump; duration 50 ms; t <sub>r</sub> > 2.5 ms	-	50	V
I <sub>ORM</sub>	repetitive peak output current	maximum output current limiting	[2] 8	-	A
I <sub>OM</sub>	peak output current	non-repetitive	-	18	A
I <sub>sink(max)</sub>	maximum sink current	pin DIAG	0	5	mA
V <sub>i</sub>	input voltage	referred to GNDD: pins SCL, SDA and OSCIO	0	5.5	V
		referred to AGND: pins ADS, MOD, SSM, EN and SEL_MUTE	0	5.5	V
		referred to AGND: pins IN1P, IN2P, IN3P, IN4P and INN	0	10	V
V <sub>o</sub>	output voltage	referred to GNDD: pin DIAG	0	10	V
R <sub>ESR</sub>	equivalent series resistance	as seen between pins V <sub>P</sub> and PGNDx	-	200	mΩ
T <sub>j</sub>	junction temperature		-	150	°C
T <sub>stg</sub>	storage temperature		-55	+150	°C
T <sub>amb</sub>	ambient temperature		-40	+85	°C
V <sub>ESD</sub>	electrostatic discharge voltage	HBM	[3]		
		C = 100 pF; R <sub>s</sub> = 1.5 kΩ	-	2000	V
		CDM	[4]		
		non-corner pins (except pin 30, V <sub>DDA</sub> )	-	500	V
		pin 30, V <sub>DDA</sub>	-	300	V
	corner pins	-	750	V	
V <sub>(prot)</sub>	protection voltage	AC and DC short circuit voltage of output pins across load and to supply and ground	[5] 0	V <sub>P</sub>	V

[1] Floating condition assumed for outputs.

[2] Current limiting concept.

[3] Human Body Model (HBM).

[4] Charged-Device Model (CDM).

[5] The output pins are defined as the output pins of the filter connected between the TDF8530 output pins and the load.

## 11. Thermal characteristics

Table 13. Thermal characteristics

Symbol	Parameter	Conditions	Typ	Unit
$R_{th(j-a)}$	thermal resistance from junction to ambient	in free air	35	K/W
$R_{th(j-c)}$	thermal resistance from junction to case		1	K/W

## 12. Static characteristics

Table 14. Static characteristics

$V_P = 14.4\text{ V}$ ;  $f_{osc} = 315\text{ kHz}$ ;  $T_{amb} = 25\text{ °C}$ ; unless otherwise specified.

Symbol	Parameter	Conditions	Min	Typ	Max	Unit
<b>Supply</b>						
$V_P$	supply voltage	Operating mode; on pins $V_{DDA}$ and $V_{P1}$ and $V_{P2}$	6	14.4	24	V
$I_P$	supply current	off state; $T_j \leq 85\text{ °C}$ ; $V_P = 14.4\text{ V}$	-	2	10	$\mu\text{A}$
$I_{q(tot)}$	total quiescent current	Operating mode; no load, no snubbers and no filter connected	-	185	200	mA
<b>I<sup>2</sup>C-bus interface: pins SCL and SDA</b>						
$V_{IL}$	LOW-level input voltage		0	-	1.5	V
$V_{IH}$	HIGH-level input voltage		2.3	-	5.5	V
$V_{OL}$	LOW-level output voltage	pin SDA; $I_{load} = 5\text{ mA}$	0	-	0.4	V
<b>Enable and SEL_MUTE input: pins EN and SEL_MUTE</b>						
$V_i$	input voltage	pin EN; off state	0	-	0.8	V
		pin EN; Standby mode; I <sup>2</sup> C-bus mode	2	-	5	V
		pin EN; Mute mode or Operating mode; non-I <sup>2</sup> C-bus mode	2	-	5	V
		pin SEL_MUTE; Mute mode; voltage on pin EN > 2 V	0	-	0.8	V
		pin SEL_MUTE; Operating mode; voltage on pin EN > 2 V	3	-	5	V
$I_i$	input current	pin EN; 2.5 V	-	-	5	$\mu\text{A}$
		pin SEL_MUTE; Operating mode; 0.8 V	-	-	50	$\mu\text{A}$

**Table 14. Static characteristics ...continued**  
 $V_P = 14.4\text{ V}$ ;  $f_{osc} = 315\text{ kHz}$ ;  $T_{amb} = 25\text{ °C}$ ; unless otherwise specified.

Symbol	Parameter	Conditions	Min	Typ	Max	Unit
<b>Diagnostic output</b>						
THD <sub>clip</sub>	total harmonic distortion clip detection level	IB3[D4] = 0	-	0.2	-	%
		IB3[D4] = 1	-	10	-	%
V <sub>th(offset)</sub>	threshold voltage for offset detection	V <sub>DDA</sub> > 8 V	[1] 1	2	3	V
V <sub>OL</sub>	LOW-level output voltage	DIAG, SCL or SDA pins; diagnostic activated; I <sub>o</sub> = 1 mA	-	-	0.3	V
I <sub>L</sub>	leakage current	DIAG, SCL or SDA pins; diagnostic not activated	-	-	50	μA
<b>Audio inputs; pins INN, IN1P, IN2P, IN3P and IN4P</b>						
V <sub>i</sub>	input voltage		-	2.45	-	V
<b>SVRR voltage and ACGND input bias voltage in Mute and Operating modes</b>						
V <sub>ref</sub>	reference voltage	input ACGND pin	-	2.45	-	V
		half supply reference SVRR pin	-	7.2	-	V
<b>Amplifier outputs; pins OUT1N, OUT1P, OUT2N, OUT2P, OUT3N, OUT3P, OUT4N and OUT4P</b>						
V <sub>O(offset)</sub>	output offset voltage	Mute mode	-	-	25	mV
		Operating mode	[2] -	-	70	mV
<b>Stabilizer output; pins VSTAB1 and VSTAB2</b>						
V <sub>o</sub>	output voltage	stabilizer output in Mute mode and Operating mode	-	11	-	V
<b>Voltage protections</b>						
V <sub>(prot)</sub>	protection voltage	undervoltage protection level 1; falling supply; IB4[D7] = 0	5.5	5.75	6	V
		undervoltage protection level 2; falling supply; IB4[D7] = 1	7.2	7.6	8	V
		overvoltage protection level	26.2	27	-	V
		V <sub>P</sub> at which a POR occurs	-	4.4	-	V
<b>Current protection</b>						
I <sub>O(ocp)</sub>	overcurrent protection output current	current limiting concept	8	9	-	A
<b>Temperature protection</b>						
T <sub>prot</sub>	protection temperature		-	152	-	°C
T <sub>act(th_fold)</sub>	thermal foldback activation temperature	gain = -1 dB	-	145	-	°C
T <sub>j(AV)(warn1)</sub>	average junction temperature for pre-warning 1	IB2[D3] = 0; non-I <sup>2</sup> C-bus mode	-	140	-	°C
T <sub>j(AV)(warn2)</sub>	average junction temperature for pre-warning 2	IB2[D3] = 1	-	120	-	°C

**DC load detection levels: I<sup>2</sup>C-bus mode only**

**Table 14. Static characteristics ...continued**  
 $V_P = 14.4\text{ V}$ ;  $f_{osc} = 315\text{ kHz}$ ;  $T_{amb} = 25\text{ °C}$ ; unless otherwise specified.

Symbol	Parameter	Conditions	Min	Typ	Max	Unit
$Z_{th(load)}$	load detection threshold impedance	for normal speaker load; IB3[D3] = 0; 1 Ω shorted load detection level	1.6	-	20	Ω
		for normal speaker load; IB3[D3] = 1; 2 Ω shorted load detection level	3.2	-	20	Ω
$Z_{th(open)}$	open load detection threshold impedance		80	-	-	Ω
$Z_{th(short)}$	shorted load detection threshold impedance	for shorted speaker load; IB3[D3] = 0; 1 Ω shorted load detection level	-	-	0.5	Ω
		for shorted speaker load; IB3[D3] = 1; 2 Ω shorted load detection level	-	-	1.5	Ω
<b>AC load detection levels: I<sup>2</sup>C-bus mode only</b>						
$I_{th(o)det(load)AC}$	AC load detection output threshold current		-	500	-	mA
<b>Start-up/shut-down/mute timing</b>						
$t_{wake}$	wake-up time	on pin EN before first I <sup>2</sup> C-bus transmission is recognized	[3]	-	500	μs
$t_{det(DCload)}$	DC load detection time	$C_{ON} = 470\text{ nF}$	[3]	-	320	ms
$t_{d(stb-mute)}$	delay time from standby to mute	measured from amplifier enabling to start of unmute (no DC load detection); $C_{SVRR} = 47\text{ μF}$	-	125	-	ms
$t_{d(mute-fgain)}$	mute to full gain delay time	$C_{ON} = 470\text{ nF}$	[4]	-	50	ms
$t_d$	delay time	shutdown delay time from EN pin LOW to SVRR LOW; voltage on pin SVRR < 1 V; $C_{SVRR} = 47\text{ μF}$ ; $C_{ON} = 470\text{ nF}$	130	190	250	ms
		shutdown hold delay time from pin EN LOW to ACGND LOW; voltage on pin ACGND < 1 V; Master mode	-	400	-	ms
		hold delay in Master mode to allow slaved devices to shut down $f_{osc} = 315\text{ kHz}$	-	50	-	ms

- [1] Maximum leakage current from DCP pin to ground = 3 μA.
- [2] DC output offset voltage is applied to the output gradually during the transition between Mute mode and Operating mode.
- [3] I<sup>2</sup>C-bus mode only.
- [4] The transition time between Mute mode and Operating mode is determined by the time constant on the SEL\_MUTE pin.

## 12.1 Switching characteristics

**Table 15. Switching characteristics**

$V_P = 14.4\text{ V}$ ;  $T_{amb} = 25\text{ °C}$ ; unless otherwise specified.

Symbol	Parameter	Conditions	Min	Typ	Max	Unit
<b>Internal oscillator</b>						
$f_{PWM}$	PWM frequency	$R_{osc} = 39\text{ k}\Omega$	-	315	-	kHz
$f_{PWM(range)}$	PWM frequency range	typical fixed frequency and Spread spectrum mode frequency based on the resistor value connected to pin OSCSET for the master setting	-	300 to 500	-	kHz
<b>Master/slave setting (OSCIO pin)</b>						
$R_{osc}$	oscillator resistance	resistor value on pin OSCSET; master setting	22	39	49	k $\Omega$
$V_{OL}$	LOW-level output voltage	output	-	-	0.8	V
$V_{OH}$	HIGH-level output voltage	output	4	-	-	V
$f_o$	output frequency	$IB3[D2] = 0$ ; $R_{osc} = 49\text{ k}\Omega$	200	250	300	kHz
		$IB3[D2] = 1$ ; $R_{osc} = 49\text{ k}\Omega$	400	500	600	kHz
		$IB3[D2] = 0$ ; $R_{osc} = 22\text{ k}\Omega$	460	500	575	kHz
		$IB3[D2] = 1$ ; $R_{osc} = 22\text{ k}\Omega$	920	1050	1150	kHz
$V_{IL}$	LOW-level input voltage	input	-	-	0.8	V
$V_{IH}$	HIGH-level input voltage	input	3	-	-	V
$f_i$	input frequency	$IB3[D2] = 0$	300	-	500	kHz
		$IB3[D2] = 1$	[1] 600	-	1000	kHz
$C_{OSCIO}$	capacitance on pin OSCIO	output, used by slave with PLL operation	-	-	560	pF
		output, used by slave without PLL operation	-	-	68	pF
<b>Spread spectrum mode setting</b>						
$\Delta f_{osc}$	oscillator frequency variation	between maximum and minimum values; Spread spectrum mode activated	-	10	-	%
$f_{sw}$	switching frequency	Spread spectrum mode activated; $C_{SSM} = 1\text{ }\mu\text{F}$	-	7	-	Hz
<b>Frequency hopping</b>						
$f_{osc(int)}$	internal oscillator frequency	change positive; $IB1[D4] = 1$ ; $IB1[D3] = 1$	-	$f_{osc} + 10\%$	-	kHz
		change negative; $IB1[D4] = 1$ ; $IB1[D3] = 0$	-	$f_{osc} - 10\%$	-	kHz

[1] Amplifier output stage switching frequency is half the external oscillator frequency.



### 13. Dynamic characteristics

**Table 16. Dynamic characteristics**

$V_P = 14.4\text{ V}$ ;  $R_L = 4\ \Omega$ ;  $f_i = 1\text{ kHz}$ ;  $f_{osc} = 315\text{ kHz}$ ;  $R_{s(L)} < 0.04\ \Omega$ <sup>[1]</sup>;  $T_{amb} = 25\text{ °C}$ ; unless otherwise specified.

Symbol	Parameter	Conditions	Min	Typ	Max	Unit
P <sub>o</sub>	output power	THD = 1 %; R <sub>L</sub> = 4 Ω	[2] 18	20	-	W
		THD = 10 %; R <sub>L</sub> = 4 Ω	24	26	-	W
		square wave (EIAJ); R <sub>L</sub> = 4 Ω	-	40	-	W
		V <sub>P</sub> = 24 V; THD = 10 %; R <sub>L</sub> = 4 Ω	-	70	-	W
		THD = 1 %; R <sub>L</sub> = 2 Ω	29	33	-	W
		THD = 10 %; R <sub>L</sub> = 2 Ω	39	45	-	W
		square wave (EIAJ); R <sub>L</sub> = 2 Ω	-	66	-	W
		V <sub>P</sub> = 24 V; THD = 10 %; R <sub>L</sub> = 2 Ω	-	100	-	W
THD	total harmonic distortion	f <sub>i</sub> = 1 kHz; P <sub>o</sub> = 1 W	[3] -	0.02	0.1	%
G <sub>v(cl)</sub>	closed-loop voltage gain		25	26	27	dB
α <sub>cs</sub>	channel separation	f <sub>i</sub> = 1 kHz; P <sub>o</sub> = 1 W	60	70	-	dB
SVRR	supply voltage rejection ratio	Operating mode				
		BD mode; f <sub>ripple</sub> = 100 Hz	[4] -	70	-	dB
		BD mode; f <sub>ripple</sub> = 1 kHz	[4] -	70	-	dB
		Mute mode				
		BD mode; f <sub>ripple</sub> = 1 kHz	[4] -	70	-	dB
		Off or Standby mode				
		BD mode; f <sub>ripple</sub> = 1 kHz	[4] -	70	-	dB
Z <sub>i(dif)</sub>	differential input impedance		30	50	75	kΩ
V <sub>n(o)</sub>	output noise voltage	Operating mode				
		BD mode	[5] -	60	77	μV
		AD mode	[5] -	100	140	μV
		Mute mode				
		BD mode	[6] -	25	32	μV
		AD mode	[6] -	95	110	μV
α <sub>bal(ch)</sub>	channel balance		-	0	1	dB
α <sub>mute</sub>	mute attenuation		[7] 70	-	-	dB
CMRR	common mode rejection ratio	V <sub>i(cm)</sub> = 1 V RMS	65	80	-	dB
η <sub>po</sub>	output power efficiency	P <sub>o</sub> = 20 W	-	90	-	%

[1] R<sub>s(L)</sub> is the sum of the inductor series resistance from the low-pass LC filter in the application together with all resistance from PCB traces or wiring between the output pin of the TDF8530 and the inductor to the measurement point. LC filter dimensioning is L = 10 μH, C = 1 μF for 4 Ω load and L = 5 μH, C = 2.2 μF for 2 Ω load.

[2] Output power is measured indirectly based on R<sub>DSon</sub> measurement.

[3] Total harmonic distortion is measured at the bandwidth of 22 Hz to 20 kHz, AES brick wall. The maximum limit is guaranteed but may not be 100 % tested.

[4] V<sub>ripple</sub> = V<sub>ripple(max)</sub> = 1 V (p-p); R<sub>s</sub> = 0 Ω.

[5] B = 22 Hz to 20 kHz, AES brick wall, R<sub>s</sub> = 0 Ω.

[6] B = 22 Hz to 20 kHz, AES brick wall, independent of R<sub>s</sub>.

[7] V<sub>i</sub> = V<sub>i(max)</sub> = 0.5 V RMS.

## 14. Application information

### 14.1 Output power estimation

The output power, just before clipping, can be estimated using [Equation 1](#):

$$P_{o(1)} = \frac{\left( \left( \frac{R_L}{R_L + 2 \times (R_{DSon} + R_s)} \right) \times \left( 1 - t_{w(min)} \times \frac{f_{osc}}{2} \right) \times V_P \right)^2}{2 \times R_L} [W] \quad (1)$$

Where,

- $V_P$  = supply voltage (V)
- $R_L$  = load impedance ( $\Omega$ )
- $R_{DSon}$  = drain source on-state resistance ( $\Omega$ )
- $R_s$  = series resistance of the output inductor ( $\Omega$ )
- $t_{w(min)}$  = minimum pulse width(s) depending on output current
- $f_{osc}$  = oscillator frequency in Hz (typically 315 kHz)

The output power at 10 % THD can be estimated using [Equation 2](#):

$$P_{o(2)} = 1.25 \times P_{o(1)} \quad (2)$$

where  $P_{o(1)} = 0.5\%$  and  $P_{o(2)} = 10\%$

[Figure 17](#) and [Figure 18](#) show the estimated output power at THD = 0.5 % and THD = 10 % as a function of supply voltage for different load impedances.

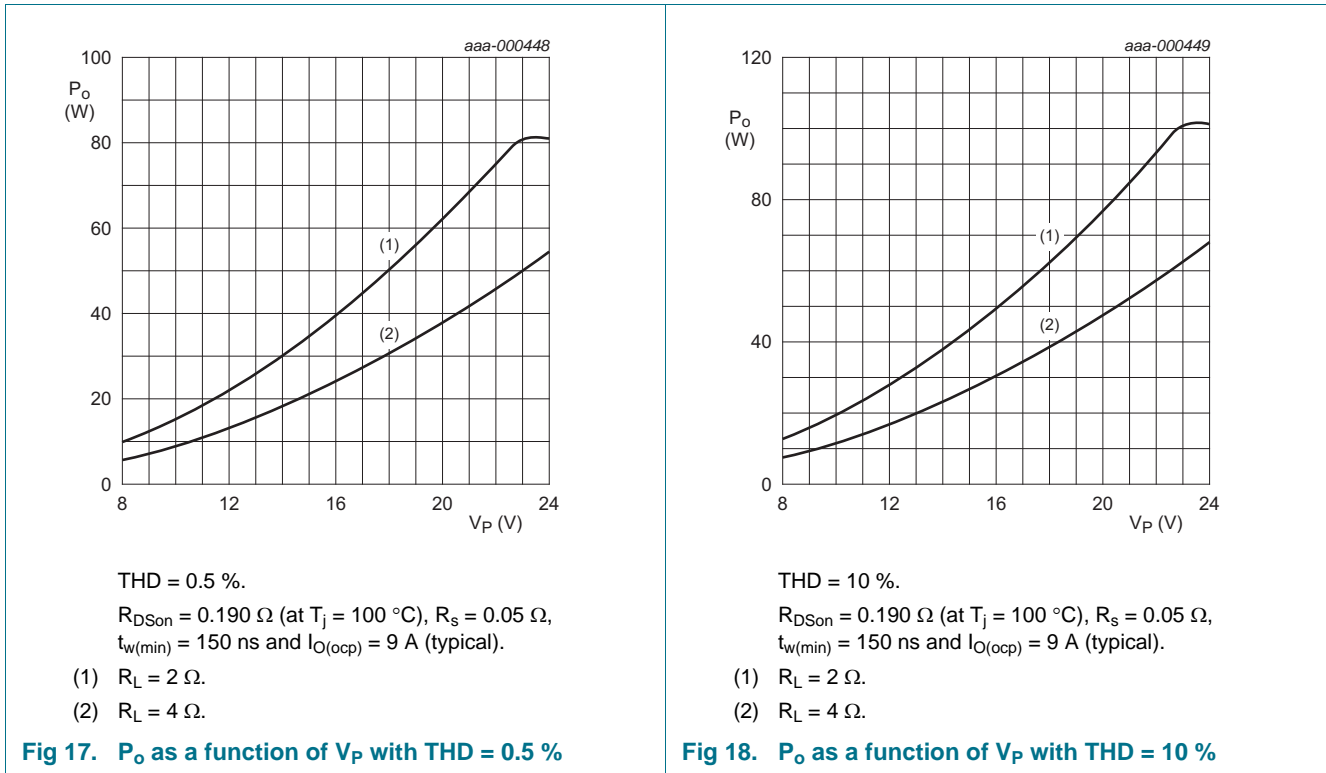

### 14.2 Output current limiting

The peak output current is internally limited to 8 A minimum. During normal operation, the output current should not exceed this threshold level otherwise the output signal will be distorted. The peak output current can be estimated using [Equation 3](#):

$$I_o \leq \frac{V_p}{R_L + 2 \times (R_{DSon} + R_s)} \leq 8 [A] \tag{3}$$

- I<sub>o</sub> = output current (A)
- V<sub>p</sub> = supply voltage (V)
- R<sub>L</sub> = load impedance (Ω)
- R<sub>DSon</sub> = on-resistance of power switch (Ω)
- R<sub>s</sub> = series resistance of output inductor (Ω)

Example: A 2 Ω speaker can be used with a supply voltage of 22 V before current limiting is triggered.

Current limiting (clipping) avoids audio holes but causes distortion similar to voltage clipping.

### 14.3 Speaker configuration and impedance

A flat-frequency response (due to a 2<sup>nd</sup> order Butterworth filter) is obtained by changing the values of low-pass filter components (L<sub>LC</sub>, C<sub>LC</sub>) based on the speaker configuration and impedance. [Figure 19](#) shows the circuit and [Table 17](#) gives the required values.

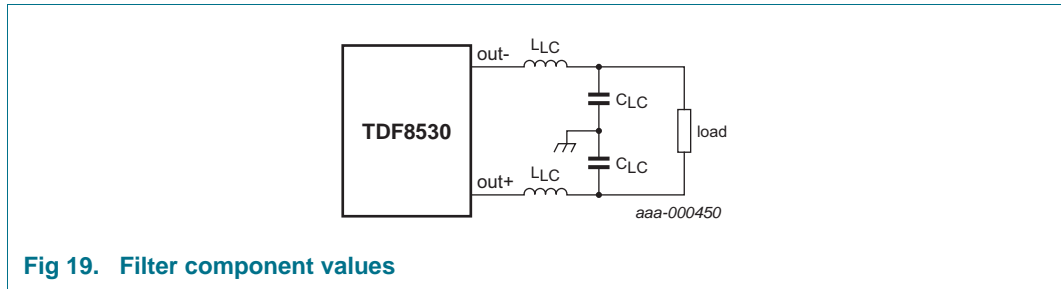

Fig 19. Filter component values

Table 17. Filter component values

Load impedance (Ω)	L <sub>LC</sub> (μH)	C <sub>LC</sub> (μF)
2	5	2.2
4	10	1

### 14.4 Heat sink requirements

In most applications, it is necessary to connect an external heat sink to the TDF8530. Thermal foldback activates at T<sub>j</sub> = 140 °C. The expression in [Equation 4](#) shows the relationship between the maximum power dissipation before activation of thermal foldback and the total thermal resistance from junction to ambient:

$$R_{th(j-a)} = \frac{T_{j(max)} - T_{amb}}{P_{max}} [K/W] \tag{4}$$

P<sub>max</sub> is determined by the efficiency (η) of the TDF8530. The efficiency measured as a function of output power is given in [Figure 25](#). The power dissipation can be derived as a function of output power (see [Figure 24](#)).

Example 1:

- V<sub>P</sub> = 14.4 V
- P<sub>O</sub> = 4 × 25 W into 4 Ω (THD = 10 % continuous)
- T<sub>j(max)</sub> = 140 °C
- T<sub>amb</sub> = 25 °C
- P<sub>max</sub> = 9.5 W (from [Figure 24](#))
- The required R<sub>th(j-a)</sub> = 115 °C / 9.5 W = 12 K/W

The total thermal resistance R<sub>th(j-a)</sub> consists of: R<sub>th(j-c)</sub> + R<sub>th(c-h)</sub> + R<sub>th(h-a)</sub>

Where:

- Thermal resistance from junction to case (R<sub>th(j-c)</sub>) = 1 K/W
- Thermal resistance from case to heat sink (R<sub>th(c-h)</sub>) = 0.5 K/W to 1 K/W (depending on mounting)
- Thermal resistance from heat sink to ambient (R<sub>th(h-a)</sub>) would then be 12 – (1 + 1) = 10 K/W.

If an audio signal has a crest factor of 10 (the ratio between peak power and average power = 10 dB) then T<sub>j</sub> will be much lower.

Example 2:

- $V_P = 14.4 \text{ V}$
- $P_o = 4 \times (25 \text{ W} / 10) = 4 \times 2.5 \text{ W}$  into  $4 \Omega$  (audio with crest factor of 10)
- $T_{amb} = 25 \text{ }^\circ\text{C}$
- $P_{max} = 4 \text{ W}$  (from [Figure 24](#))
- $R_{th(j-a)} = 12 \text{ K/W}$
- $T_{j(max)} = 25 \text{ }^\circ\text{C} + (4 \text{ W} \times 12 \text{ K/W}) = 73 \text{ }^\circ\text{C}$

14.5 Curves measured in reference design

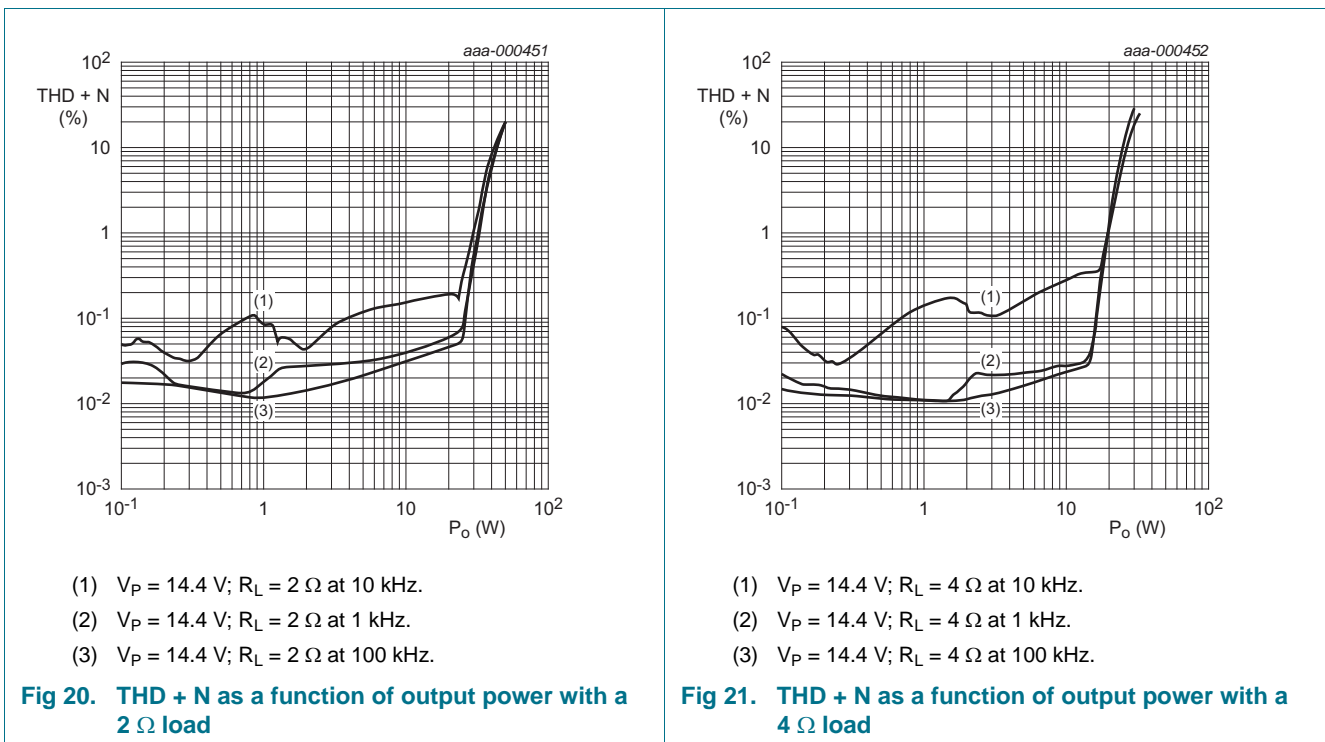

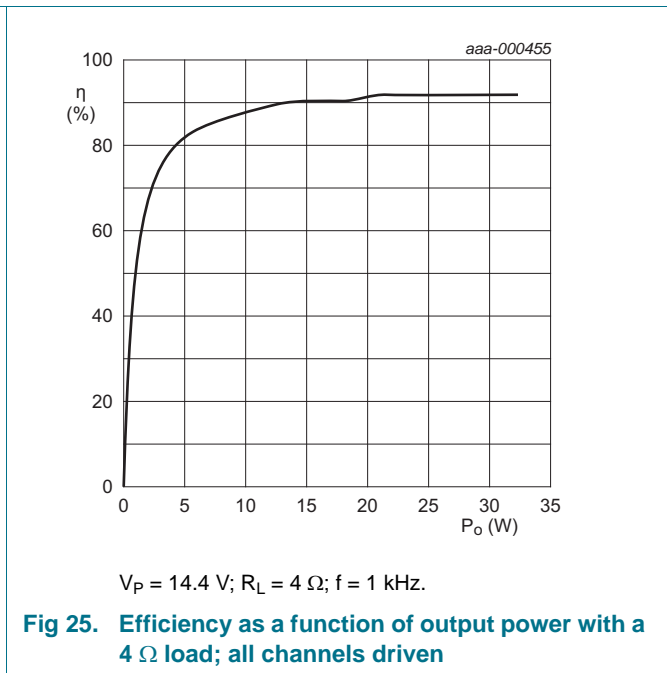
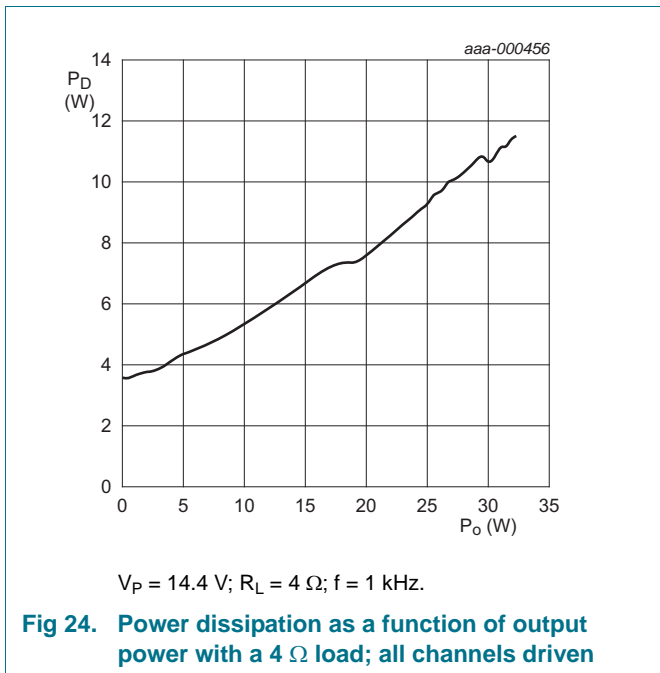
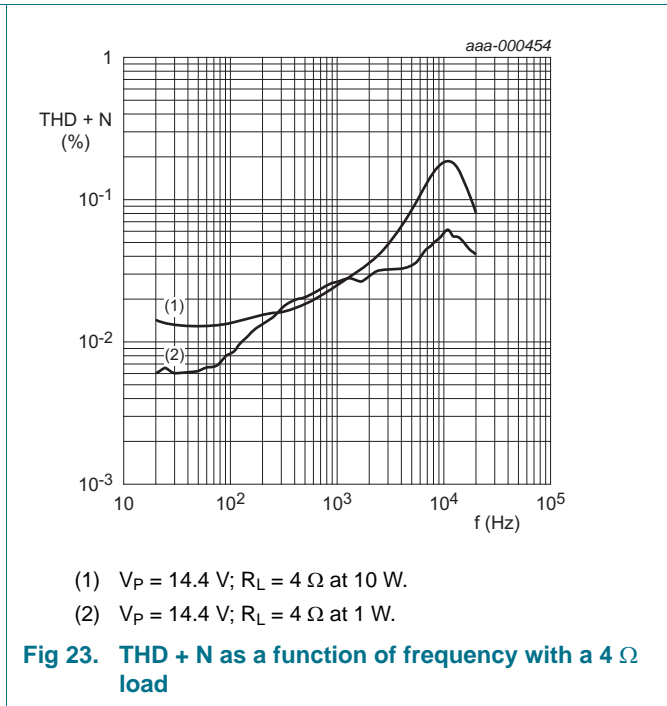
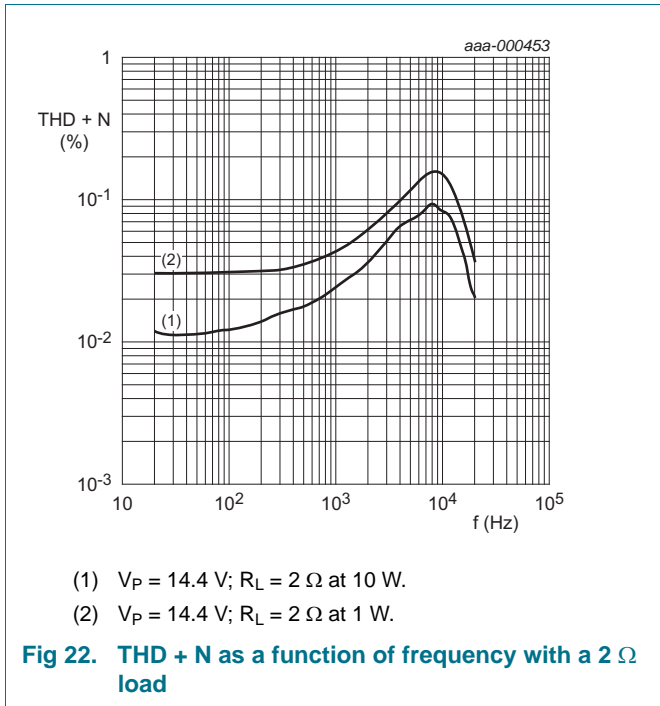

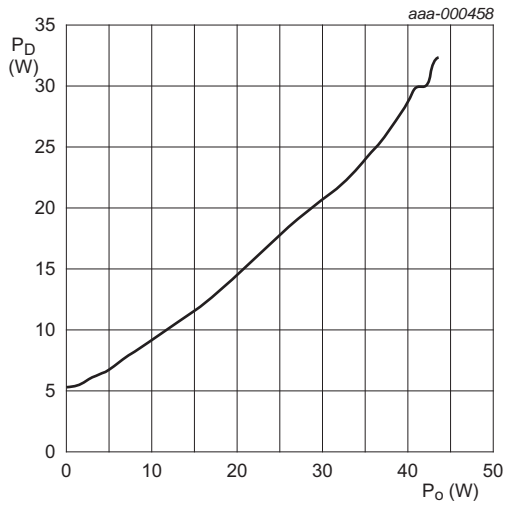

$V_P = 14.4\text{ V}$ ;  $R_L = 4\ \Omega$ ;  $f = 1\text{ kHz}$ .

**Fig 26. Power dissipation as a function of output power with a 2  $\Omega$  load; all channels driven**

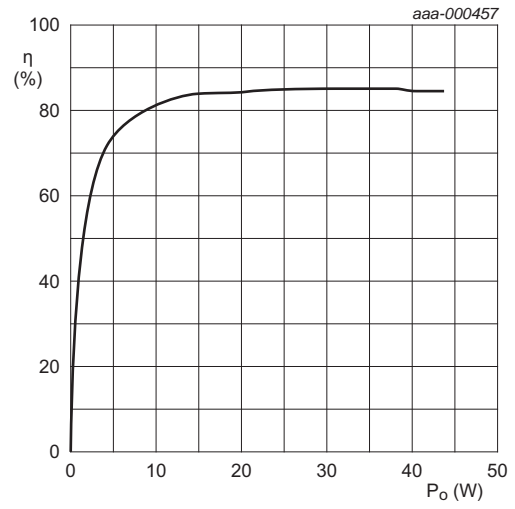

$V_P = 14.4\text{ V}$ ;  $R_L = 4\ \Omega$ ;  $f = 1\text{ kHz}$ .

**Fig 27. Efficiency as a function of output power with a 2  $\Omega$  load; all channels driven**

14.6 Typical application schematics

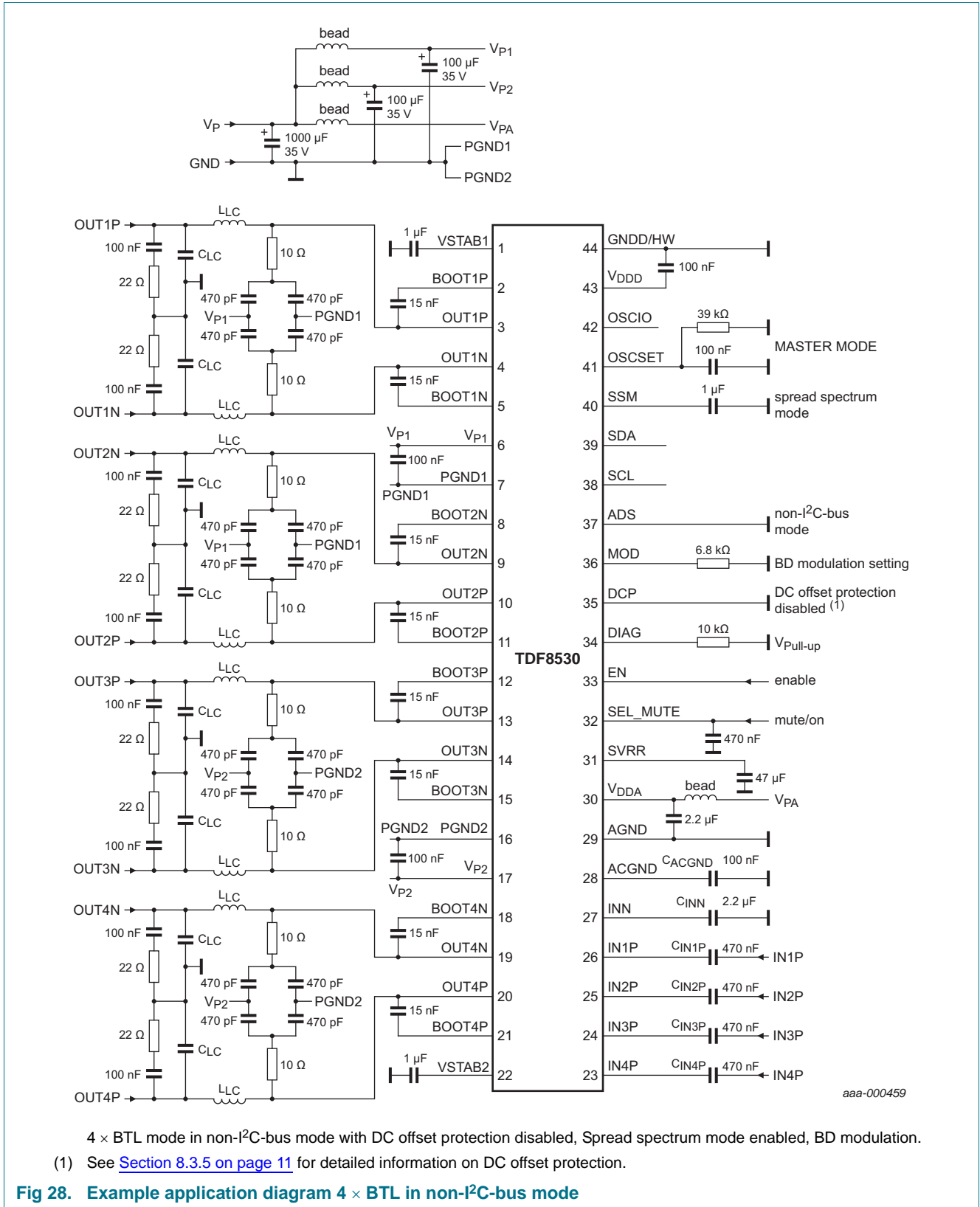



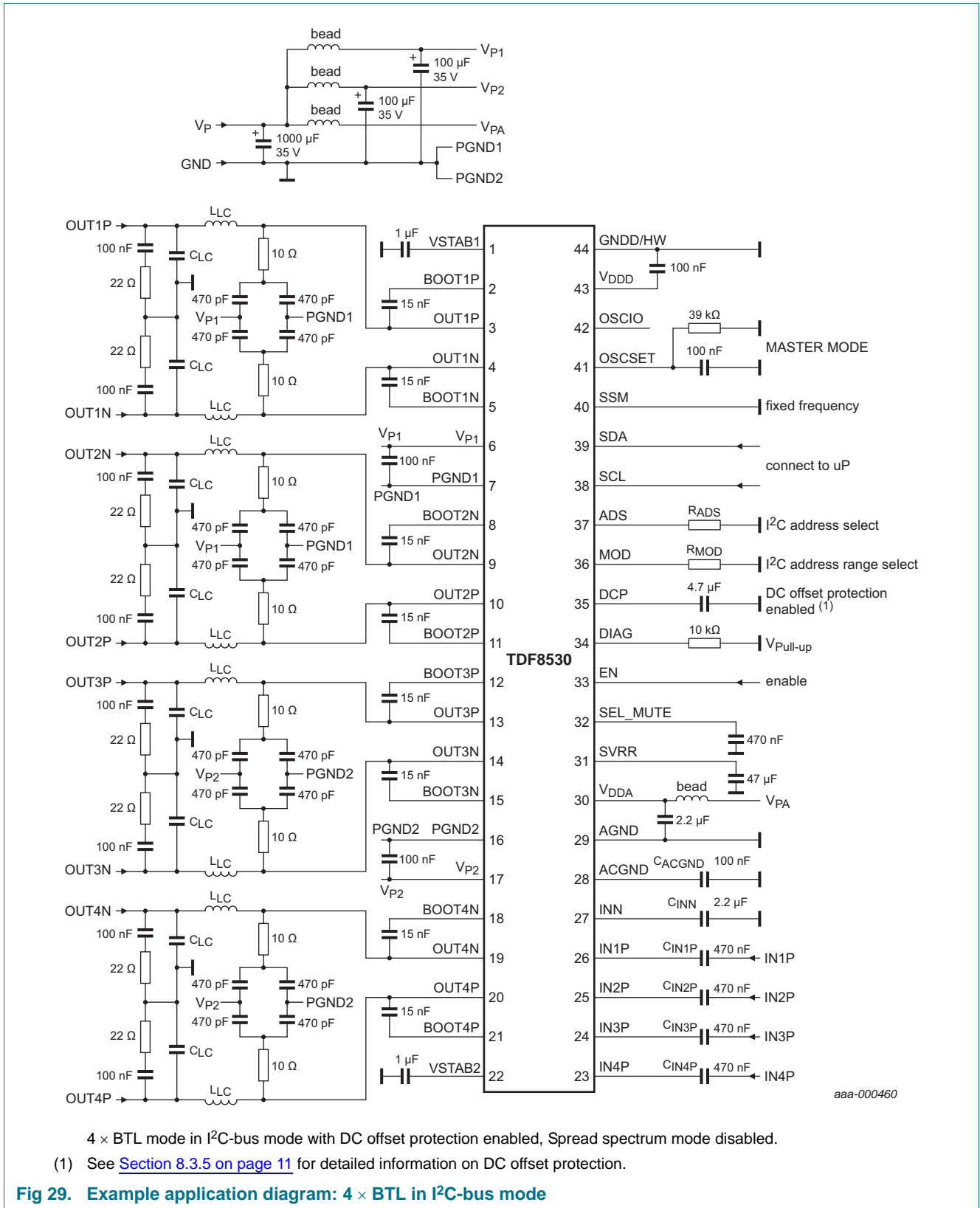

15. Package outline

HSOP44: plastic, heatsink small outline package; 44 leads; low stand-off height

SOT1131-1

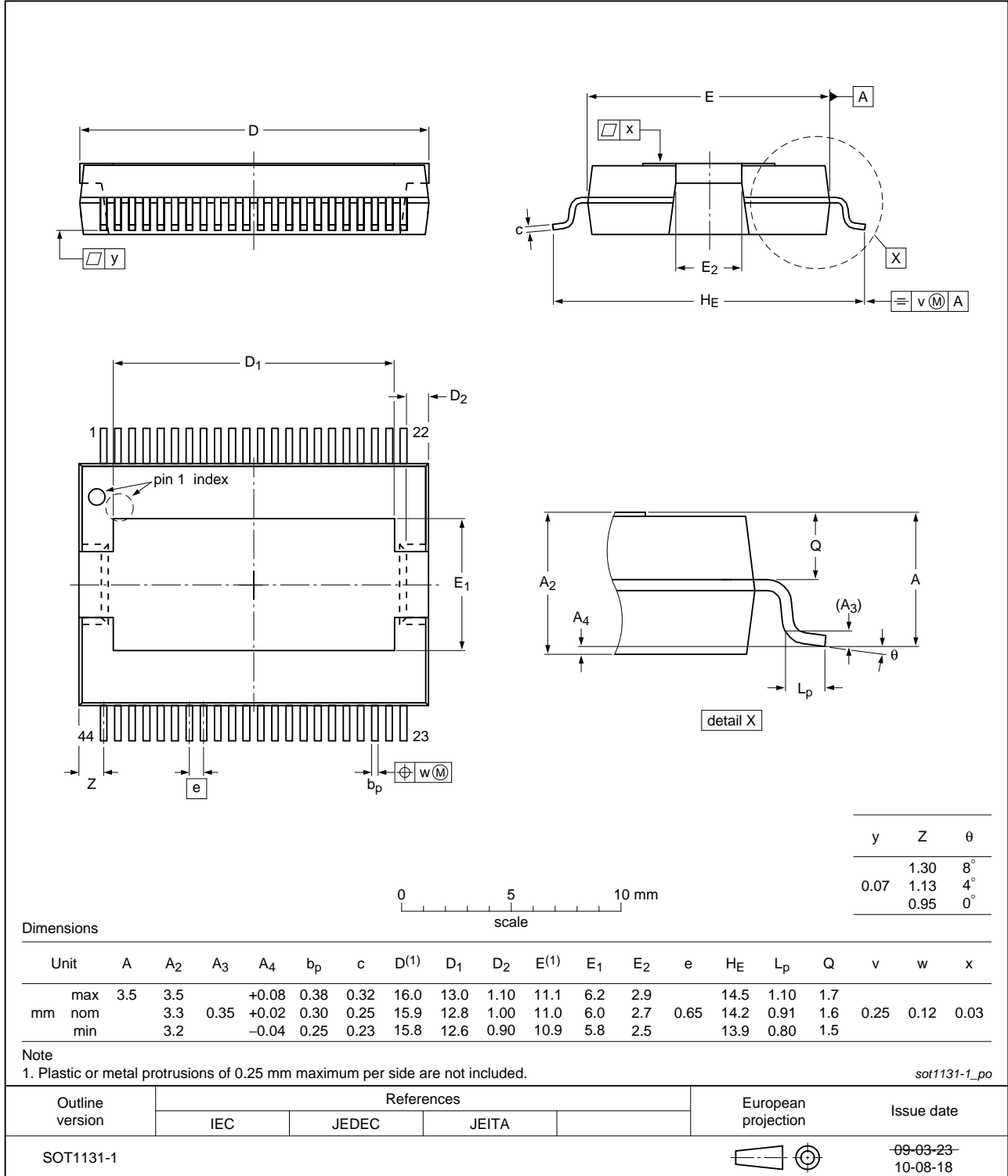

Fig 30. Package outline SOT1131-1 (HSOP44)

## 16. Soldering of SMD packages

This text provides a very brief insight into a complex technology. A more in-depth account of soldering ICs can be found in Application Note *AN10365 "Surface mount reflow soldering description"*.

### 16.1 Introduction to soldering

Soldering is one of the most common methods through which packages are attached to Printed Circuit Boards (PCBs), to form electrical circuits. The soldered joint provides both the mechanical and the electrical connection. There is no single soldering method that is ideal for all IC packages. Wave soldering is often preferred when through-hole and Surface Mount Devices (SMDs) are mixed on one printed wiring board; however, it is not suitable for fine pitch SMDs. Reflow soldering is ideal for the small pitches and high densities that come with increased miniaturization.

### 16.2 Wave and reflow soldering

Wave soldering is a joining technology in which the joints are made by solder coming from a standing wave of liquid solder. The wave soldering process is suitable for the following:

- Through-hole components
- Leaded or leadless SMDs, which are glued to the surface of the printed circuit board

Not all SMDs can be wave soldered. Packages with solder balls, and some leadless packages which have solder lands underneath the body, cannot be wave soldered. Also, leaded SMDs with leads having a pitch smaller than ~0.6 mm cannot be wave soldered, due to an increased probability of bridging.

The reflow soldering process involves applying solder paste to a board, followed by component placement and exposure to a temperature profile. Leaded packages, packages with solder balls, and leadless packages are all reflow solderable.

Key characteristics in both wave and reflow soldering are:

- Board specifications, including the board finish, solder masks and vias
- Package footprints, including solder thieves and orientation
- The moisture sensitivity level of the packages
- Package placement
- Inspection and repair
- Lead-free soldering versus SnPb soldering

### 16.3 Wave soldering

Key characteristics in wave soldering are:

- Process issues, such as application of adhesive and flux, clinching of leads, board transport, the solder wave parameters, and the time during which components are exposed to the wave
- Solder bath specifications, including temperature and impurities

### 16.4 Reflow soldering

Key characteristics in reflow soldering are:

- Lead-free versus SnPb soldering; note that a lead-free reflow process usually leads to higher minimum peak temperatures (see [Figure 31](#)) than a SnPb process, thus reducing the process window
- Solder paste printing issues including smearing, release, and adjusting the process window for a mix of large and small components on one board
- Reflow temperature profile; this profile includes preheat, reflow (in which the board is heated to the peak temperature) and cooling down. It is imperative that the peak temperature is high enough for the solder to make reliable solder joints (a solder paste characteristic). In addition, the peak temperature must be low enough that the packages and/or boards are not damaged. The peak temperature of the package depends on package thickness and volume and is classified in accordance with [Table 18](#) and [19](#)

**Table 18. SnPb eutectic process (from J-STD-020C)**

Package thickness (mm)	Package reflow temperature (°C)	
	Volume (mm <sup>3</sup> )	
	< 350	≥ 350
< 2.5	235	220
≥ 2.5	220	220

**Table 19. Lead-free process (from J-STD-020C)**

Package thickness (mm)	Package reflow temperature (°C)		
	Volume (mm <sup>3</sup> )		
	< 350	350 to 2000	> 2000
< 1.6	260	260	260
1.6 to 2.5	260	250	245
> 2.5	250	245	245

Moisture sensitivity precautions, as indicated on the packing, must be respected at all times.

Studies have shown that small packages reach higher temperatures during reflow soldering, see [Figure 31](#).

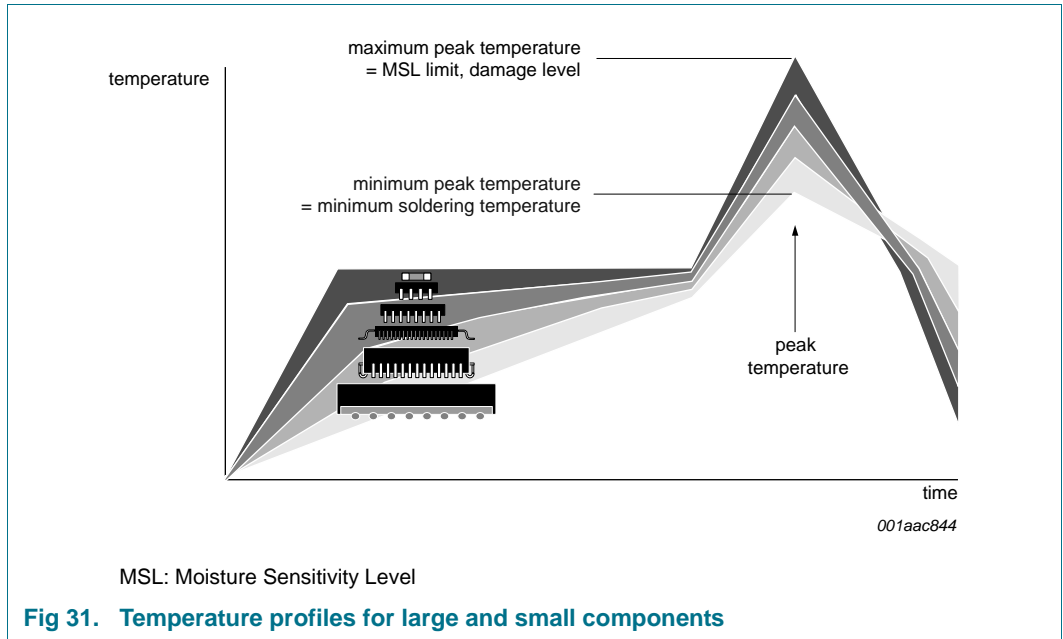

For further information on temperature profiles, refer to Application Note AN10365 “Surface mount reflow soldering description”.

## 17. Abbreviations

**Table 20. Abbreviations**

Abbreviation	Description
BCDMOS	Bipolar Complementary and double Diffused Metal-Oxide Semiconductor
BTL	Bridge-Tied Load
DCP	DC offset Protection
DMOST	double Diffused Metal-Oxide Semiconductor Transistor
EMI	ElectroMagnetic Interference
THD	Total Harmonic Distortion
I <sup>2</sup> C	Inter-Integrated Circuit
LSB	Least Significant Bit
M $\mu$ p	Master microprocessor
MSB	Most Significant Bit
NDMOST	N-type double Diffused Metal-Oxide Semiconductor Transistor
OCP	OverCurrent Protection
OTP	OverTemperature Protection
OVP	OverVoltage Protection
PLL	Phase-Locked Loop
POR	Power-On Reset
PWM	Pulse-Width Modulation
SOI	Silicon-On-Insulator

Table 20. Abbreviations ...continued

Abbreviation	Description
TFP	Thermal Foldback Protection
UVP	UnderVoltage Protection
WP	Window Protection

## 18. Revision history

Table 21. Revision history

Document ID	Release date	Data sheet status	Change notice	Supersedes
TDF8530_SDS v.3	20111020	Product short data sheet	-	TDF8530_SDS v.2
Modifications:	<ul style="list-style-type: none"> <li>Data sheet status changed from Objective short data sheet to Product short data sheet.</li> </ul>			
TDF8530_SDS v.2	20111014	Objective short data sheet	-	TDF8530_SDS v.1
Modifications:	<ul style="list-style-type: none"> <li>Changed Table 15 on page 24: Changes to internal oscillator parameters and output frequency data.</li> </ul>			
TDF8530_SDS v.1	20111011	Objective short data sheet	-	-

## 19. Legal information

### 19.1 Data sheet status

Document status <sup>[1][2]</sup>	Product status <sup>[3]</sup>	Definition
Objective [short] data sheet	Development	This document contains data from the objective specification for product development.
Preliminary [short] data sheet	Qualification	This document contains data from the preliminary specification.
Product [short] data sheet	Production	This document contains the product specification.

[1] Please consult the most recently issued document before initiating or completing a design.

[2] The term 'short data sheet' is explained in section "Definitions".

[3] The product status of device(s) described in this document may have changed since this document was published and may differ in case of multiple devices. The latest product status information is available on the Internet at URL <http://www.nxp.com>.

### 19.2 Definitions

**Draft** — The document is a draft version only. The content is still under internal review and subject to formal approval, which may result in modifications or additions. NXP Semiconductors does not give any representations or warranties as to the accuracy or completeness of information included herein and shall have no liability for the consequences of use of such information.

**Short data sheet** — A short data sheet is an extract from a full data sheet with the same product type number(s) and title. A short data sheet is intended for quick reference only and should not be relied upon to contain detailed and full information. For detailed and full information see the relevant full data sheet, which is available on request via the local NXP Semiconductors sales office. In case of any inconsistency or conflict with the short data sheet, the full data sheet shall prevail.

**Product specification** — The information and data provided in a Product data sheet shall define the specification of the product as agreed between NXP Semiconductors and its customer, unless NXP Semiconductors and customer have explicitly agreed otherwise in writing. In no event however, shall an agreement be valid in which the NXP Semiconductors product is deemed to offer functions and qualities beyond those described in the Product data sheet.

### 19.3 Disclaimers

**Limited warranty and liability** — Information in this document is believed to be accurate and reliable. However, NXP Semiconductors does not give any representations or warranties, expressed or implied, as to the accuracy or completeness of such information and shall have no liability for the consequences of use of such information.

In no event shall NXP Semiconductors be liable for any indirect, incidental, punitive, special or consequential damages (including - without limitation - lost profits, lost savings, business interruption, costs related to the removal or replacement of any products or rework charges) whether or not such damages are based on tort (including negligence), warranty, breach of contract or any other legal theory.

Notwithstanding any damages that customer might incur for any reason whatsoever, NXP Semiconductors' aggregate and cumulative liability towards customer for the products described herein shall be limited in accordance with the *Terms and conditions of commercial sale* of NXP Semiconductors.

**Right to make changes** — NXP Semiconductors reserves the right to make changes to information published in this document, including without limitation specifications and product descriptions, at any time and without notice. This document supersedes and replaces all information supplied prior to the publication hereof.

**Suitability for use** — NXP Semiconductors products are not designed, authorized or warranted to be suitable for use in life support, life-critical or safety-critical systems or equipment, nor in applications where failure or

malfunction of an NXP Semiconductors product can reasonably be expected to result in personal injury, death or severe property or environmental damage. NXP Semiconductors accepts no liability for inclusion and/or use of NXP Semiconductors products in such equipment or applications and therefore such inclusion and/or use is at the customer's own risk.

**Applications** — Applications that are described herein for any of these products are for illustrative purposes only. NXP Semiconductors makes no representation or warranty that such applications will be suitable for the specified use without further testing or modification.

Customers are responsible for the design and operation of their applications and products using NXP Semiconductors products, and NXP Semiconductors accepts no liability for any assistance with applications or customer product design. It is customer's sole responsibility to determine whether the NXP Semiconductors product is suitable and fit for the customer's applications and products planned, as well as for the planned application and use of customer's third party customer(s). Customers should provide appropriate design and operating safeguards to minimize the risks associated with their applications and products.

NXP Semiconductors does not accept any liability related to any default, damage, costs or problem which is based on any weakness or default in the customer's applications or products, or the application or use by customer's third party customer(s). Customer is responsible for doing all necessary testing for the customer's applications and products using NXP Semiconductors products in order to avoid a default of the applications and the products or of the application or use by customer's third party customer(s). NXP does not accept any liability in this respect.

**Limiting values** — Stress above one or more limiting values (as defined in the Absolute Maximum Ratings System of IEC 60134) will cause permanent damage to the device. Limiting values are stress ratings only and (proper) operation of the device at these or any other conditions above those given in the Recommended operating conditions section (if present) or the Characteristics sections of this document is not warranted. Constant or repeated exposure to limiting values will permanently and irreversibly affect the quality and reliability of the device.

**Terms and conditions of commercial sale** — NXP Semiconductors products are sold subject to the general terms and conditions of commercial sale, as published at <http://www.nxp.com/profile/terms>, unless otherwise agreed in a valid written individual agreement. In case an individual agreement is concluded only the terms and conditions of the respective agreement shall apply. NXP Semiconductors hereby expressly objects to applying the customer's general terms and conditions with regard to the purchase of NXP Semiconductors products by customer.

**No offer to sell or license** — Nothing in this document may be interpreted or construed as an offer to sell products that is open for acceptance or the grant, conveyance or implication of any license under any copyrights, patents or other industrial or intellectual property rights.

**Export control** — This document as well as the item(s) described herein may be subject to export control regulations. Export might require a prior authorization from competent authorities.

**Quick reference data** — The Quick reference data is an extract of the product data given in the Limiting values and Characteristics sections of this document, and as such is not complete, exhaustive or legally binding.

**Non-automotive qualified products** — Unless this data sheet expressly states that this specific NXP Semiconductors product is automotive qualified, the product is not suitable for automotive use. It is neither qualified nor tested in accordance with automotive testing or application requirements. NXP Semiconductors accepts no liability for inclusion and/or use of non-automotive qualified products in automotive equipment or applications.

In the event that customer uses the product for design-in and use in automotive applications to automotive specifications and standards, customer (a) shall use the product without NXP Semiconductors' warranty of the product for such automotive applications, use and specifications, and (b)

whenever customer uses the product for automotive applications beyond NXP Semiconductors' specifications such use shall be solely at customer's own risk, and (c) customer fully indemnifies NXP Semiconductors for any liability, damages or failed product claims resulting from customer design and use of the product for automotive applications beyond NXP Semiconductors' standard warranty and NXP Semiconductors' product specifications.

## 19.4 Trademarks

Notice: All referenced brands, product names, service names and trademarks are the property of their respective owners.

**I<sup>2</sup>C-bus** — logo is a trademark of NXP B.V.

## 20. Contact information

For more information, please visit: <http://www.nxp.com>

For sales office addresses, please send an email to: [salesaddresses@nxp.com](mailto:salesaddresses@nxp.com)



## 21. Contents

<b>1</b>	<b>General description</b> . . . . .	<b>1</b>	16.1	Introduction to soldering	35
<b>2</b>	<b>Features and benefits</b> . . . . .	<b>1</b>	16.2	Wave and reflow soldering	35
<b>3</b>	<b>Applications</b> . . . . .	<b>2</b>	16.3	Wave soldering	35
<b>4</b>	<b>Quick reference data</b> . . . . .	<b>2</b>	16.4	Reflow soldering	36
<b>5</b>	<b>Ordering information</b> . . . . .	<b>2</b>	<b>17</b>	<b>Abbreviations</b> . . . . .	<b>37</b>
<b>6</b>	<b>Block diagram</b> . . . . .	<b>3</b>	<b>18</b>	<b>Revision history</b> . . . . .	<b>38</b>
<b>7</b>	<b>Pinning information</b> . . . . .	<b>4</b>	<b>19</b>	<b>Legal information</b> . . . . .	<b>39</b>
7.1	Pinning . . . . .	4	19.1	Data sheet status . . . . .	39
7.2	Pin description . . . . .	4	19.2	Definitions . . . . .	39
<b>8</b>	<b>Functional description</b> . . . . .	<b>6</b>	19.3	Disclaimers . . . . .	39
8.1	Master and slave mode selection . . . . .	6	19.4	Trademarks . . . . .	40
8.2	Operation mode selection . . . . .	6	<b>20</b>	<b>Contact information</b> . . . . .	<b>40</b>
8.2.1	Modulation mode . . . . .	7	<b>21</b>	<b>Contents</b> . . . . .	<b>41</b>
8.2.2	Phase staggering (Slave mode) . . . . .	8			
8.3	Protection . . . . .	9			
8.3.1	Thermal foldback . . . . .	10			
8.3.2	Overtemperature protection . . . . .	10			
8.3.3	Overcurrent protection . . . . .	10			
8.3.4	Window protection . . . . .	10			
8.3.5	DC offset protection . . . . .	11			
8.3.6	Supply voltage protection . . . . .	11			
8.4	Diagnostic output . . . . .	11			
8.4.1	Diagnostic table . . . . .	11			
8.4.2	Load identification (I <sup>2</sup> C-bus mode only) . . . . .	12			
8.4.2.1	DC load detection . . . . .	12			
8.4.2.2	AC load detection (tweeter detection) . . . . .	13			
8.4.3	Clip detection . . . . .	14			
8.4.4	Start-up and shutdown sequence . . . . .	14			
<b>9</b>	<b>I<sup>2</sup>C-bus specification</b> . . . . .	<b>16</b>			
9.1	Instruction bytes . . . . .	18			
9.2	Data bytes . . . . .	19			
<b>10</b>	<b>Limiting values</b> . . . . .	<b>20</b>			
<b>11</b>	<b>Thermal characteristics</b> . . . . .	<b>21</b>			
<b>12</b>	<b>Static characteristics</b> . . . . .	<b>21</b>			
12.1	Switching characteristics . . . . .	24			
<b>13</b>	<b>Dynamic characteristics</b> . . . . .	<b>25</b>			
<b>14</b>	<b>Application information</b> . . . . .	<b>26</b>			
14.1	Output power estimation . . . . .	26			
14.2	Output current limiting . . . . .	27			
14.3	Speaker configuration and impedance . . . . .	27			
14.4	Heat sink requirements . . . . .	28			
14.5	Curves measured in reference design . . . . .	29			
14.6	Typical application schematics . . . . .	32			
<b>15</b>	<b>Package outline</b> . . . . .	<b>34</b>			
<b>16</b>	<b>Soldering of SMD packages</b> . . . . .	<b>35</b>			

Please be aware that important notices concerning this document and the product(s) described herein, have been included in section 'Legal information'.

© NXP B.V. 2011. All rights reserved.

For more information, please visit: <http://www.nxp.com>  
 For sales office addresses, please send an email to: [salesaddresses@nxp.com](mailto:salesaddresses@nxp.com)

Date of release: 20 October 2011  
 Document identifier: TDF8530\_SDS



Компания «ЭлектроПласт» предлагает заключение долгосрочных отношений при поставках импортных электронных компонентов на взаимовыгодных условиях!

Наши преимущества:

- Оперативные поставки широкого спектра электронных компонентов отечественного и импортного производства напрямую от производителей и с крупнейших мировых складов;
- Поставка более 17-ти миллионов наименований электронных компонентов;
- Поставка сложных, дефицитных, либо снятых с производства позиций;
- Оперативные сроки поставки под заказ (от 5 рабочих дней);
- Экспресс доставка в любую точку России;
- Техническая поддержка проекта, помощь в подборе аналогов, поставка прототипов;
- Система менеджмента качества сертифицирована по Международному стандарту ISO 9001;
- Лицензия ФСБ на осуществление работ с использованием сведений, составляющих государственную тайну;
- Поставка специализированных компонентов (Xilinx, Altera, Analog Devices, Intersil, Interpoint, Microsemi, Aeroflex, Peregrine, Syfer, Eurofarad, Texas Instrument, Miteq, Cobham, E2V, MA-COM, Hittite, Mini-Circuits, General Dynamics и др.);

Помимо этого, одним из направлений компании «ЭлектроПласт» является направление «Источники питания». Мы предлагаем Вам помощь Конструкторского отдела:

- Подбор оптимального решения, техническое обоснование при выборе компонента;
- Подбор аналогов;
- Консультации по применению компонента;
- Поставка образцов и прототипов;
- Техническая поддержка проекта;
- Защита от снятия компонента с производства.



#### Как с нами связаться

**Телефон:** 8 (812) 309 58 32 (многоканальный)

**Факс:** 8 (812) 320-02-42

**Электронная почта:** [org@eplast1.ru](mailto:org@eplast1.ru)

**Адрес:** 198099, г. Санкт-Петербург, ул. Калинина, дом 2, корпус 4, литера А.