

FEATURES

Complete quad, 16-bit digital-to-analog converter (DAC)
Programmable output range
 $\pm 10\text{ V}$, $\pm 10.2564\text{ V}$, or $\pm 10.5263\text{ V}$
 ± 1 LSB maximum INL error, ± 1 LSB maximum DNL error
Low noise: 60 nV/ $\sqrt{\text{Hz}}$
Settling time: 10 μs maximum
Integrated reference buffers
Output control during power-up/brownout
Programmable short-circuit protection
Simultaneous updating via $\overline{\text{LDAC}}$
Asynchronous $\overline{\text{CLR}}$ to zero code
Digital offset and gain adjust
Logic output control pins
DSP-/microcontroller-compatible serial interface
Temperature range: -40°C to $+85^{\circ}\text{C}$
iCMOS process technology¹

APPLICATIONS

Industrial automation
Open-loop/closed-loop servo control
Process control
Data acquisition systems
Automatic test equipment
Automotive test and measurement
High accuracy instrumentation

GENERAL DESCRIPTION

The AD5764 is a quad, 16-bit, serial input, bipolar voltage output DAC that operates from supply voltages of $\pm 11.4\text{ V}$ to $\pm 16.5\text{ V}$. Nominal full-scale output range is $\pm 10\text{ V}$. The AD5764 provides integrated output amplifiers, reference buffers, and proprietary power-up/power-down control circuitry. The part also features a digital I/O port that is programmed via the serial interface. The part incorporates digital offset and gain adjust registers per channel.

The AD5764 is a high performance converter that offers guaranteed monotonicity, integral nonlinearity (INL) of ± 1 LSB, low noise, and 10 μs settling time. During power-up (when the supply voltages are changing), $\text{VOU}_{\text{T}x}$ is clamped to 0 V via a low impedance path.

The AD5764 uses a serial interface that operates at clock rates of up to 30 MHz and is compatible with DSP and microcontroller interface standards. Double buffering allows the simultaneous updating of all DACs. The input coding is programmable to either twos complement or offset binary formats. The asynchronous clear function clears the data register to either bipolar zero or zero scale depending on the coding used. The AD5764 is ideal for both closed-loop servo control and open-loop control applications. The AD5764 is available in a 32-lead TQFP, and offers guaranteed specifications over the -40°C to $+85^{\circ}\text{C}$ industrial temperature range. See Figure 1 for the functional block diagram.

Table 1. Related Devices

Part No.	Description
AD5764R	AD5764 with internal voltage reference
AD5744R	Complete quad, 14-bit, high accuracy, serial input, bipolar voltage output DAC with internal voltage reference

¹ For analog systems designers within industrial/instrumentation equipment OEMs who need high performance ICs at higher voltage levels, iCMOS[®] is a technology platform that enables the development of analog ICs capable of 30 V and operating at $\pm 15\text{ V}$ supplies, allowing dramatic reductions in power consumption and package size, and increased ac and dc performance.

Rev. F

Information furnished by Analog Devices is believed to be accurate and reliable. However, no responsibility is assumed by Analog Devices for its use, nor for any infringements of patents or other rights of third parties that may result from its use. Specifications subject to change without notice. No license is granted by implication or otherwise under any patent or patent rights of Analog Devices. Trademarks and registered trademarks are the property of their respective owners.

TABLE OF CONTENTS

Features	1	Function Register	21
Applications.....	1	Data Register.....	21
General Description.....	1	Coarse Gain Register	21
Revision History	2	Fine Gain Register.....	22
Functional Block Diagram	3	Offset Register	22
Specifications.....	4	Offset and Gain Adjustment Worked Example.....	23
AC Performance Characteristics	5	Design Features.....	24
Timing Characteristics	6	Analog Output Control	24
Absolute Maximum Ratings.....	9	Digital Offset and Gain Control.....	24
ESD Caution.....	9	Programmable Short-Circuit Protection	24
Pin Configuration and Function Descriptions.....	10	Digital I/O Port.....	24
Typical Performance Characteristics	12	Local Ground Offset Adjust.....	24
Terminology	17	Applications Information	25
Theory of Operation	18	Typical Operating Circuit	25
DAC Architecture.....	18	Layout Guidelines.....	27
Reference Buffers.....	18	Galvanically Isolated Interface	27
Serial Interface	18	Microprocessor Interfacing.....	27
Simultaneous Updating via $\overline{\text{LDAC}}$	19	Evaluation Board.....	27
Transfer Function	20	Outline Dimensions	28
Asynchronous Clear ($\overline{\text{CLR}}$).....	20	Ordering Guide	28
REVISION HISTORY		Changes to Table 20	26
9/11—Rev. E to Rev. F		Deleted AD5764 to MC68HC11 Interface Section.....	27
Changed 30 MHz to 50 MHz Throughout.....	1	Deleted Figure 38; Renumbered Sequentially	27
Changes to t_1 , t_2 , and t_3 Parameters, Table 4.....	6	Deleted AD5764 to 8XC51 Interface Section, Figure 39, AD5764 to ADSP-2101 Interface Section, Figure 40, and AD5764 to PIC16C6x/PIC16C7x Interface Section	28
7/11—Rev. D to Rev. E		04/08—Rev. A to Rev. B	
Changed 30 MHz to 50 MHz Throughout.....	1	Changes to Table Summary Statement, Specifications Section...4	
Changes to t_1 , t_2 , and t_3 Parameters, Table 4.....	6	Changes to Power Requirements Parameter, Table 2 and Table Summary Statement.....	5
8/09—Rev. C to Rev. D		Changes to t_{16} Parameter, Table 4	6
Changes to Table 2 and Table 3 Endnotes	6	Changes to Table 6.....	10
Changes to t_6 Parameter and Endnotes, Table 4.....	7	Changed V_{SS}/V_{DD} to AV_{SS}/AV_{DD} in Typical Performance Characteristics Section	13
1/09—Rev. B to Rev. C		Changes to Table 16	22
Changes to General Description Section	1	Changes to Table 18	23
Changes to Figure 1.....	3	Changes to Typical Operating Circuit Section	28
Changes to Table 2 Conditions	4	Changes to AD5764 to ADSP-2101 Section	29
Changes to Table 3 Conditions	5	Changes to Ordering Guide	30
Changes to Table 4 Conditions	6	1/07—Rev. 0 to Rev. A	
Changes to Figure 5.....	8	Changes to Absolute Maximum Ratings.....	10
Changes to Table 5.....	9	Changes to Figure 25 and Figure 26.....	16
Changes to Table 6.....	10	3/06—Revision 0: Initial Version	
Changes to Figure 34.....	19		
Changes to Table 7 and Table 10.....	20		
Added Table 8; Renumbered Sequentially	20		
Changes to Table 11 and Table 12	21		
Changes to Digital Offset and Gain Control Section	24		

FUNCTIONAL BLOCK DIAGRAM

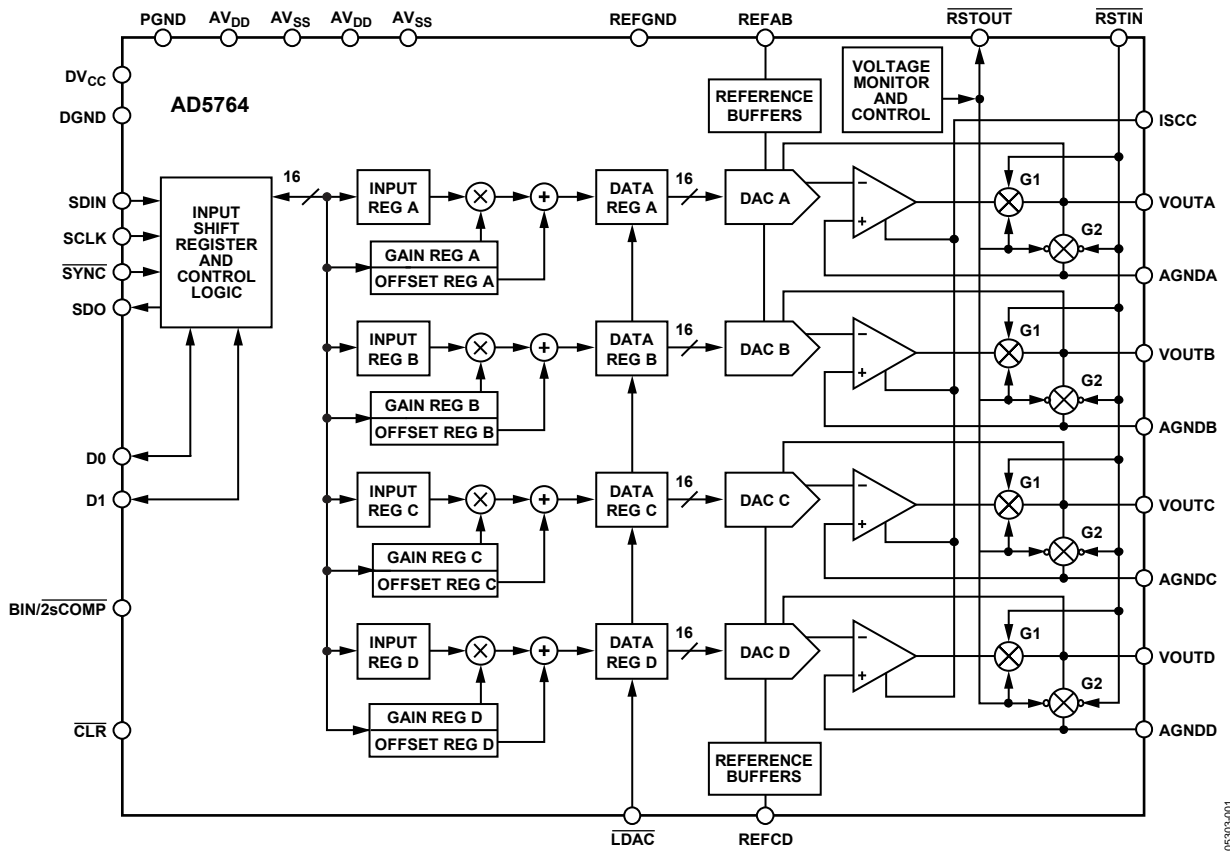

Figure 1.

05303-001

SPECIFICATIONS

$AV_{DD} = 11.4\text{ V to }16.5\text{ V}$, $AV_{SS} = -11.4\text{ V to }-16.5\text{ V}$, $AGND_x = DGND = REFGND = PGND = 0\text{ V}$; $REFAB = REFCD = 5\text{ V}$;
 $DV_{CC} = 2.7\text{ V to }5.25\text{ V}$, $R_{LOAD} = 10\text{ k}\Omega$, $C_L = 200\text{ pF}$. Temperature range: $-40^\circ\text{C to }+85^\circ\text{C}$; typical at $+25^\circ\text{C}$. Device functionality is guaranteed to $+105^\circ\text{C}$ with degraded performance. All specifications T_{MIN} to T_{MAX} , unless otherwise noted.

Table 2.

Parameter	A Grade	B Grade	C Grade	Unit	Test Conditions/Comments
ACCURACY					Outputs unloaded
Resolution	16	16	16	Bits	
Relative Accuracy (INL)	± 4	± 2	± 1	LSB max	
Differential Nonlinearity	± 1	± 1	± 1	LSB max	Guaranteed monotonic
Bipolar Zero Error	± 2	± 2	± 2	mV max	At 25°C ; error at other temperatures obtained using bipolar zero TC
Bipolar Zero Temperature Coefficient (TC) ¹	± 2	± 2	± 2	ppm FSR/ $^\circ\text{C}$ max	
Zero-Scale Error	± 2	± 2	± 2	mV max	At 25°C ; error at other temperatures obtained using zero-scale TC
Zero-Scale TC ¹	± 2	± 2	± 2	ppm FSR/ $^\circ\text{C}$ max	
Gain Error	± 0.02	± 0.02	± 0.02	% FSR max	At 25°C ; error at other temperatures obtained using gain TC
Gain TC ¹	± 2	± 2	± 2	ppm FSR/ $^\circ\text{C}$ max	
DC Crosstalk ¹	0.5	0.5	0.5	LSB max	
REFERENCE INPUT ¹					
Reference Input Voltage	5	5	5	V nom	$\pm 1\%$ for specified performance
DC Input Impedance	1	1	1	M Ω min	Typically 100 M Ω
Input Current	± 10	± 10	± 10	μA max	Typically $\pm 30\text{ nA}$
Reference Range	1 to 7	1 to 7	1 to 7	V min to V max	
OUTPUT CHARACTERISTICS ¹					
Output Voltage Range ²	± 10.5263 ± 14	± 10.5263 ± 14	± 10.5263 ± 14	V min to V max V min to V max	$AV_{DD}/AV_{SS} = \pm 11.4\text{ V}$, $V_{REFIN} = 5\text{ V}$ $AV_{DD}/AV_{SS} = \pm 16.5\text{ V}$, $V_{REFIN} = 7\text{ V}$
Output Voltage Drift vs. Time	± 13 ± 15	± 13 ± 15	± 13 ± 15	ppm FSR/ 500 hours typ ppm FSR/ 1000 hours typ	
Short-Circuit Current	10	10	10	mA typ	$R_{ISCC} = 6\text{ k}\Omega$, see Figure 31
Load Current	± 1	± 1	± 1	mA max	For specified performance
Capacitive Load Stability					
$R_{LOAD} = \infty$	200	200	200	pF max	
$R_{LOAD} = 10\text{ k}\Omega$	1000	1000	1000	pF max	
DC Output Impedance	0.3	0.3	0.3	Ω max	
DIGITAL INPUTS					$DV_{CC} = 2.7\text{ V to }5.25\text{ V}$, JEDEC compliant
Input High Voltage, V_{IH}	2	2	2	V min	
Input Low Voltage, V_{IL}	0.8	0.8	0.8	V max	
Input Current	± 1	± 1	± 1	μA max	Per pin
Pin Capacitance	10	10	10	pF max	Per pin

Parameter	A Grade	B Grade	C Grade	Unit	Test Conditions/Comments
DIGITAL OUTPUTS (D0, D1, SDO)¹					
Output Low Voltage	0.4	0.4	0.4	V max	DV _{CC} = 5 V ± 5%, sinking 200 μA
Output High Voltage	DV _{CC} - 1	DV _{CC} - 1	DV _{CC} - 1	V min	DV _{CC} = 5 V ± 5%, sourcing 200 μA
Output Low Voltage	0.4	0.4	0.4	V max	DV _{CC} = 2.7 V to 3.6 V, sinking 200 μA
Output High Voltage	DV _{CC} - 0.5	DV _{CC} - 0.5	DV _{CC} - 0.5	V min	DV _{CC} = 2.7 V to 3.6 V, sourcing 200 μA
High Impedance Leakage Current	±1	±1	±1	μA max	SDO only
High Impedance Output Capacitance	5	5	5	pF typ	SDO only
POWER REQUIREMENTS					
AV _{DD} /AV _{SS}	±11.4 to ±16.5	±11.4 to ±16.5	±11.4 to ±16.5	V min to V max	
DV _{CC}	2.7 to 5.25	2.7 to 5.25	2.7 to 5.25	V min to V max	
Power Supply Sensitivity ¹					
ΔV _{OUT} /ΔAV _{DD}	-85	-85	-85	dB typ	
AI _{DD}	3.5	3.5	3.5	mA/channel max	Outputs unloaded
AI _{SS}	2.75	2.75	2.75	mA/channel max	Outputs unloaded
DI _{CC}	1.2	1.2	1.2	mA max	V _H = DV _{CC} , V _{IL} = DGND, 750 μA typical
Power Dissipation	275	275	275	mW typ	±12 V operation output unloaded

¹ Guaranteed by design and characterization; not production tested.

² Output amplifier headroom requirement is 1.4 V minimum.

AC PERFORMANCE CHARACTERISTICS

AV_{DD} = 11.4 V to 16.5 V, AV_{SS} = -11.4 V to -16.5 V, AGND_X = DGND = REFGND = PGND = 0 V; REFAB = REFCD = 5 V; DV_{CC} = 2.7 V to 5.25 V, R_{LOAD} = 10 kΩ, C_L = 200 pF. All specifications T_{MIN} to T_{MAX}, unless otherwise noted.

Table 3.

Parameter	A Grade	B Grade	C Grade	Unit	Test Conditions/Comments
DYNAMIC PERFORMANCE¹					
Output Voltage Settling Time	8	8	8	μs typ	Full-scale step to ±1 LSB
	10	10	10	μs max	
	2	2	2	μs typ	
Slew Rate	5	5	5	V/μs typ	512 LSB step settling
	5	5	5	V/μs typ	
Digital-to-Analog Glitch Energy	8	8	8	nV-sec typ	
Glitch Impulse Peak Amplitude	25	25	25	mV max	
Channel-to-Channel Isolation	80	80	80	dB typ	
DAC-to-DAC Crosstalk	8	8	8	nV-sec typ	
Digital Crosstalk	2	2	2	nV-sec typ	
Digital Feedthrough	2	2	2	nV-sec typ	Effect of input bus activity on DAC outputs
Output Noise (0.1 Hz to 10 Hz)	0.1	0.1	0.1	LSB p-p typ	
Output Noise (0.1 Hz to 100 kHz)	45	45	45	μV rms max	
1/f Corner Frequency	1	1	1	kHz typ	
Output Noise Spectral Density	60	60	60	nV/√Hz typ	Measured at 10 kHz
Complete System Output Noise Spectral Density ²	80	80	80	nV/√Hz typ	Measured at 10 kHz

¹ Guaranteed by design and characterization; not production tested.

² Includes noise contributions from integrated reference buffers, 16-bit DAC, and output amplifier.

TIMING CHARACTERISTICS

$AV_{DD} = 11.4\text{ V to }16.5\text{ V}$, $AV_{SS} = -11.4\text{ V to }-16.5\text{ V}$, $AGND_x = DGND = REFGND = PGND = 0\text{ V}$; $REFAB = REFCD = 5\text{ V}$;
 $DV_{CC} = 2.7\text{ V to }5.25\text{ V}$, $R_{LOAD} = 10\text{ k}\Omega$, $C_L = 200\text{ pF}$. All specifications T_{MIN} to T_{MAX} , unless otherwise noted.

Table 4.

Parameter ^{1, 2, 3}	Limit at T_{MIN} , T_{MAX}	Unit	Description
t_1	33	ns min	SCLK cycle time
t_2	13	ns min	SCLK high time
t_3	13	ns min	SCLK low time
t_4	13	ns min	\overline{SYNC} falling edge to SCLK falling edge setup time
t_5^4	13	ns min	24 th SCLK falling edge to \overline{SYNC} rising edge
t_6	90	ns min	Minimum \overline{SYNC} high time
t_7	2	ns min	Data setup time
t_8	5	ns min	Data hold time
t_9	1.7	μs min	\overline{SYNC} rising edge to \overline{LDAC} falling edge (all DACs updated)
	480	ns min	\overline{SYNC} rising edge to \overline{LDAC} falling edge (single DAC updated)
t_{10}	10	ns min	\overline{LDAC} pulse width low
t_{11}	500	ns max	\overline{LDAC} falling edge to DAC output response time
t_{12}	10	μs max	DAC output settling time
t_{13}	10	ns min	\overline{CLR} pulse width low
t_{14}	2	μs max	\overline{CLR} pulse activation time
$t_{15}^{5, 6}$	25	ns max	SCLK rising edge to SDO valid
t_{16}	13	ns min	\overline{SYNC} rising edge to SCLK falling edge
t_{17}	2	μs max	\overline{SYNC} rising edge to DAC output response time ($\overline{LDAC} = 0$)
t_{18}	170	ns min	\overline{LDAC} falling edge to \overline{SYNC} rising edge

¹ Guaranteed by design and characterization; not production tested.

² All input signals are specified with $t_r = t_f = 5\text{ ns}$ (10% to 90% of DV_{CC}) and timed from a voltage level of 1.2 V.

³ See Figure 2, Figure 3, and Figure 4.

⁴ Standalone mode only.

⁵ Measured with the load circuit of Figure 5.

⁶ Daisy-chain mode only.

Timing Diagrams

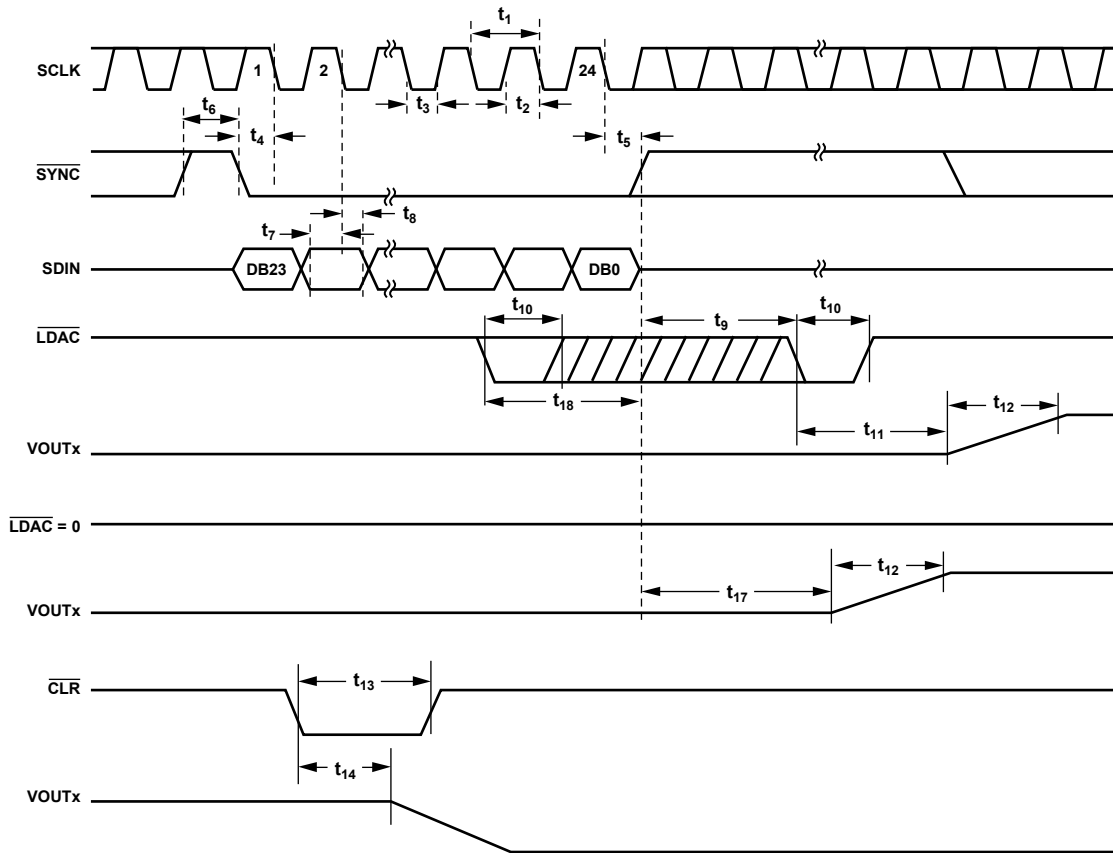

Figure 2. Serial Interface Timing Diagram

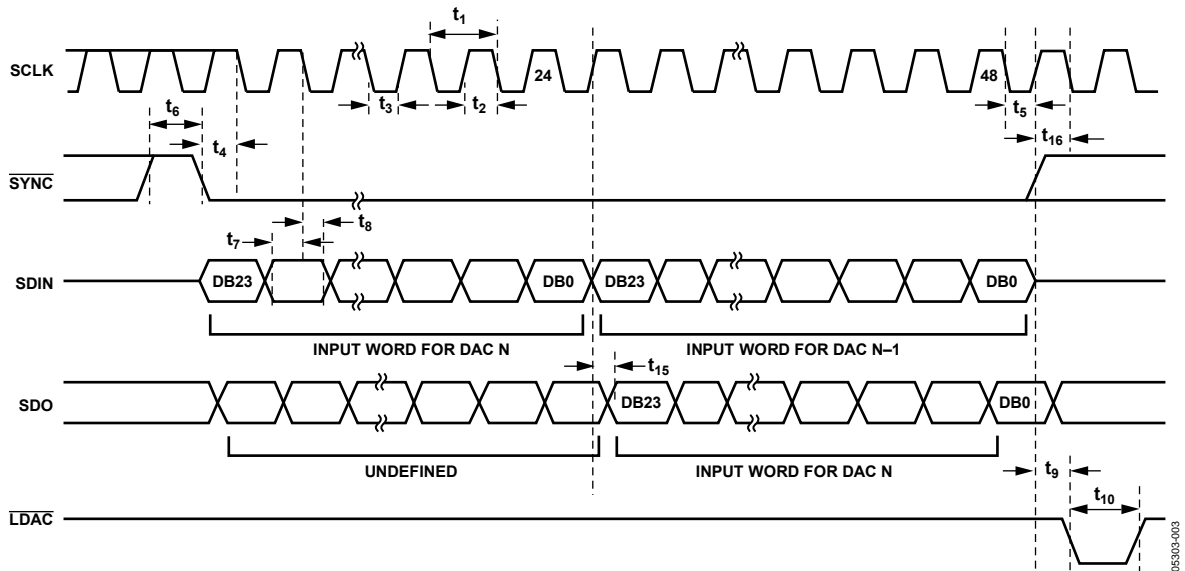

Figure 3. Daisy-Chain Timing Diagram

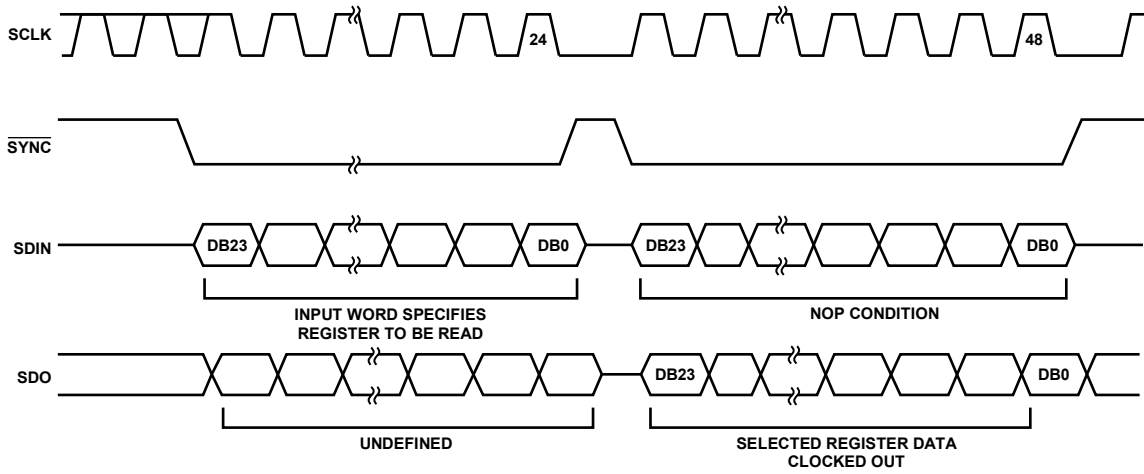

Figure 4. Readback Timing Diagram

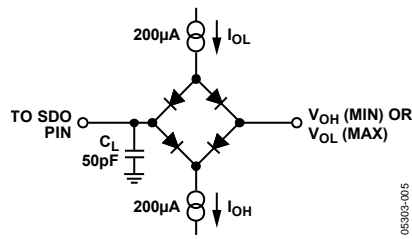

Figure 5. Load Circuit for SDO Timing Diagram

ABSOLUTE MAXIMUM RATINGS

$T_A = 25^\circ\text{C}$, unless otherwise noted. Transient currents of up to 100 mA do not cause SCR latch-up.

Table 5.

Parameter	Rating
AV_{DD} to AGNDx, DGND	-0.3 V to +17 V
AV_{SS} to AGNDx, DGND	+0.3 V to -17 V
DV_{CC} to DGND	-0.3 V to +7 V
Digital Inputs to DGND	-0.3 V to $DV_{CC} + 0.3$ V or 7 V (whichever is less)
Digital Outputs to DGND	-0.3 V to $DV_{CC} + 0.3$ V
REFAB, REFCD to AGNDx, PGND	-0.3 V to $AV_{DD} + 0.3$ V
VOUTA, VOUTB, VOUTC, VOUTD to AGNDx	AV_{SS} to AV_{DD}
AGNDx to DGND	-0.3 V to +0.3 V
Operating Temperature Range	
Industrial	-40°C to +85°C
Storage Temperature Range	-65°C to +150°C
Junction Temperature (T_J max)	150°C
32-Lead TQFP	
θ_{JA} Thermal Impedance	65°C/W
θ_{JC} Thermal Impedance	12°C/W
Lead Temperature	JEDEC industry standard
Soldering	J-STD-020

Stresses above those listed under Absolute Maximum Ratings may cause permanent damage to the device. This is a stress rating only; functional operation of the device at these or any other conditions above those listed in the operational sections of this specification is not implied. Exposure to absolute maximum rating conditions for extended periods may affect device reliability.

ESD CAUTION



ESD (electrostatic discharge) sensitive device. Charged devices and circuit boards can discharge without detection. Although this product features patented or proprietary protection circuitry, damage may occur on devices subjected to high energy ESD. Therefore, proper ESD precautions should be taken to avoid performance degradation or loss of functionality.

PIN CONFIGURATION AND FUNCTION DESCRIPTIONS

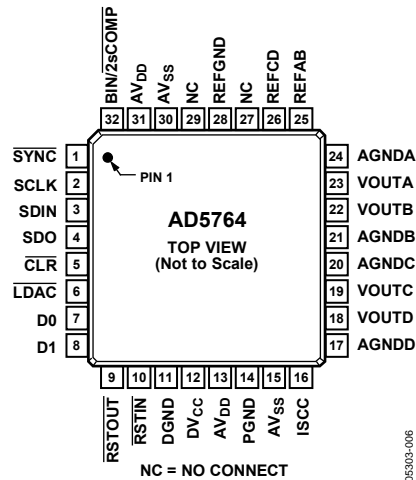

Figure 6. Pin Configuration

Table 6. Pin Function Descriptions

Pin No.	Mnemonic	Description
1	SYNC	Active Low Input. This is the frame synchronization signal for the serial interface. While SYNC is low, data is transferred in on the falling edge of SCLK.
2	SCLK	Serial Clock Input. Data is clocked into the input shift register on the falling edge of SCLK. This operates at clock speeds up to 30 MHz.
3	SDIN	Serial Data Input. Data must be valid on the falling edge of SCLK.
4	SDO	Serial Data Output. Used to clock data from the serial register in daisy-chain or readback mode.
5	CLR	Negative Edge Triggered Input. Asserting this pin sets the data register to 0x0000. There is an internal pull-up device on this logic input. Therefore, this pin can be left floating and defaults to a Logic 1 condition.
6	LDAC	Load DAC. Logic input. This is used to update the data register and consequently the analog outputs. When tied permanently low, the addressed data register is updated on the rising edge of SYNC. If LDAC is held high during the write cycle, the DAC input shift register is updated but the output update is held off until the falling edge of LDAC. In this mode, all analog outputs can be updated simultaneously on the falling edge of LDAC. The LDAC pin must not be left unconnected.
7, 8	D0, D1	Digital I/O Port. The user can set up these pins as inputs or outputs that are configurable and readable over the serial interface. When configured as inputs, these pins have weak internal pull-ups to DV _{CC} . When programmed as outputs, D0 and D1 are referenced by DV _{CC} and DGND.
9	RSTOUT	Reset Logic Output. This is the output from the on-chip voltage monitor used in the reset circuit. If desired, it can be used to control other system components.
10	RSTIN	Reset Logic Input. This input allows external access to the internal reset logic. Applying a Logic 0 to this input clamps the DAC outputs to 0 V. In normal operation, RSTIN should be tied to Logic 1. Register values remain unchanged.
11	DGND	Digital Ground.
12	DV _{CC}	Digital Supply. Voltage ranges from 2.7 V to 5.25 V.
13, 31	AV _{DD}	Positive Analog Supply. Voltage ranges from 11.4 V to 16.5 V.
14	PGND	Ground Reference Point for Analog Circuitry.
15, 30	AV _{SS}	Negative Analog Supply. Voltage ranges from -11.4 V to -16.5 V.
16	ISCC	Resistor Connection for Pin Programmable Short-Circuit Current. This pin is used in association with an optional external resistor to AGND to program the short-circuit current of the output amplifiers. Refer to the Design Features section for further details.
17	AGNDD	Ground Reference Pin for DAC D Output Amplifier.
18	VOUTD	Analog Output Voltage of DAC D. This pin is a buffered output with a nominal full-scale output range of ±10 V. The output amplifier is capable of directly driving a 10 kΩ, 200 pF load.
19	VOUTC	Analog Output Voltage of DAC C. This pin is a buffered output with a nominal full-scale output range of ±10 V. The output amplifier is capable of directly driving a 10 kΩ, 200 pF load.
20	AGNDC	Ground Reference Pin for DAC C Output Amplifier.

Pin No.	Mnemonic	Description
21	AGNDB	Ground Reference Pin for DAC B Output Amplifier.
22	VOUTB	Analog Output Voltage of DAC B. Buffered output with a nominal full-scale output range of ± 10 V. The output amplifier is capable of directly driving a 10 k Ω , 200 pF load.
23	VOUTA	Analog Output Voltage of DAC A. Buffered output with a nominal full-scale output range of ± 10 V. The output amplifier is capable of directly driving a 10 k Ω , 200 pF load.
24	AGNDA	Ground Reference Pin for DAC A Output Amplifier.
25	REFAB	External Reference Voltage Input for Channel A and Channel B. Reference input range is 1 V to 7 V; programs the full-scale output voltage. $V_{REFIN} = 5$ V for specified performance.
26	REFCD	External Reference Voltage Input for Channel C and Channel D. Reference input range is 1 V to 7 V; programs the full-scale output voltage. $V_{REFIN} = 5$ V for specified performance.
27, 29	NC	No Connect.
28	REFGND	Reference Ground Return for the Reference Generator and Buffers.
32	BIN/ $\overline{2sCOMP}$	Determines the DAC Coding. This pin should be hardwired to either DV_{CC} or DGND. When hardwired to DV_{CC} , input coding is offset binary. When hardwired to DGND, input coding is twos complement (see Table 7 and Table 8).

TYPICAL PERFORMANCE CHARACTERISTICS

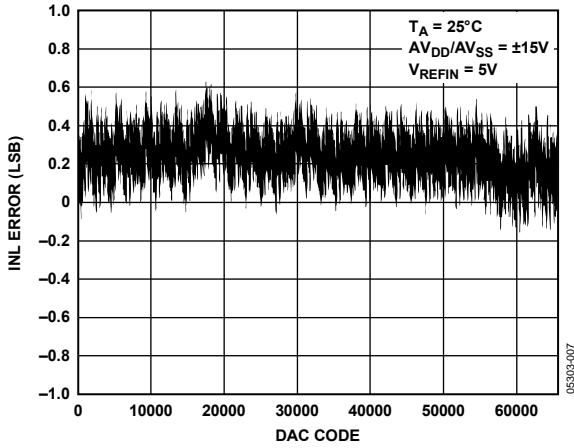

Figure 7. Integral Nonlinearity Error vs. Code, $AV_{DD}/AV_{SS} = \pm 15 V$

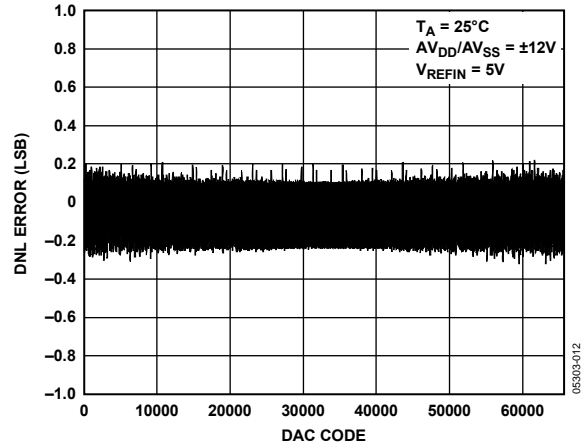

Figure 10. Differential Nonlinearity Error vs. Code, $AV_{DD}/AV_{SS} = \pm 12 V$

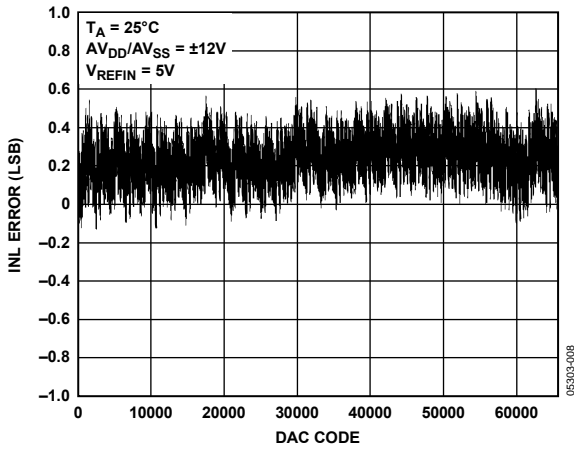

Figure 8. Integral Nonlinearity Error vs. Code, $AV_{DD}/AV_{SS} = \pm 12 V$

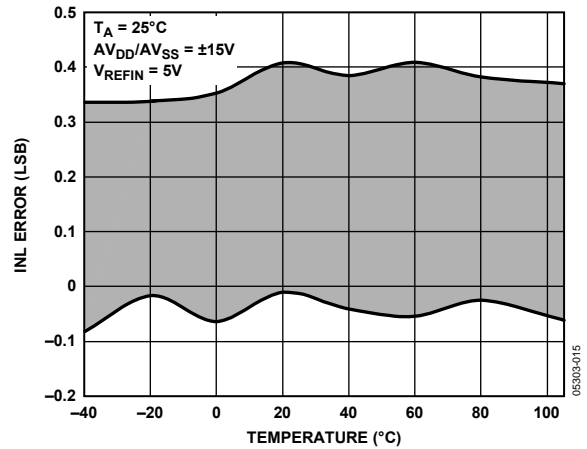

Figure 11. Integral Nonlinearity Error vs. Temperature, $AV_{DD}/AV_{SS} = \pm 15 V$

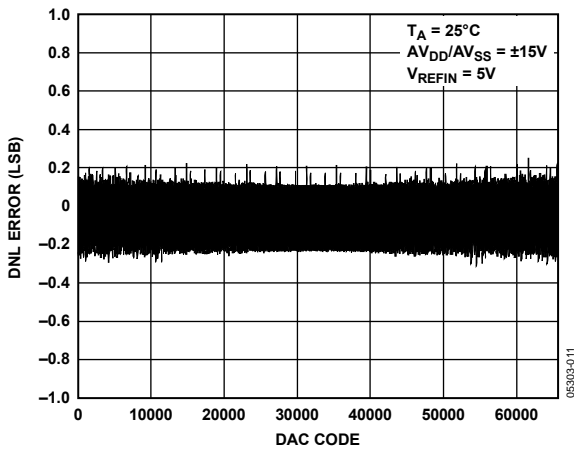

Figure 9. Differential Nonlinearity Error vs. Code, $AV_{DD}/AV_{SS} = \pm 15 V$

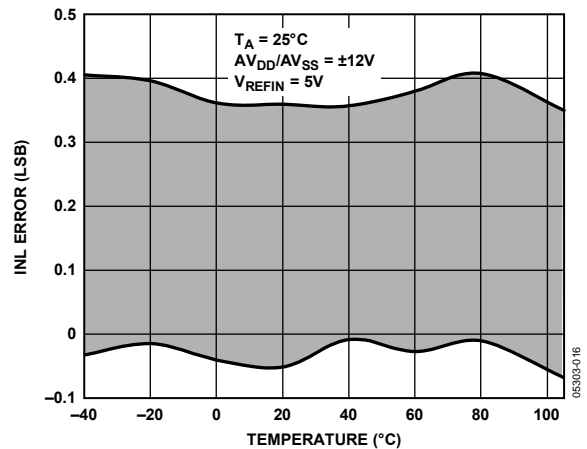

Figure 12. Integral Nonlinearity Error vs. Temperature, $AV_{DD}/AV_{SS} = \pm 12 V$

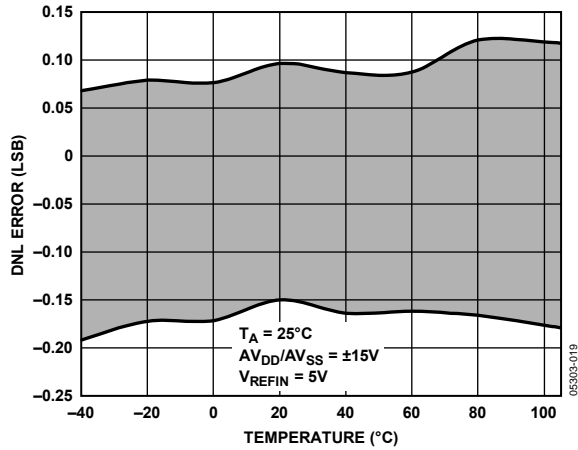

Figure 13. Differential Nonlinearity Error vs. Temperature, $AV_{DD}/AV_{SS} = \pm 15V$

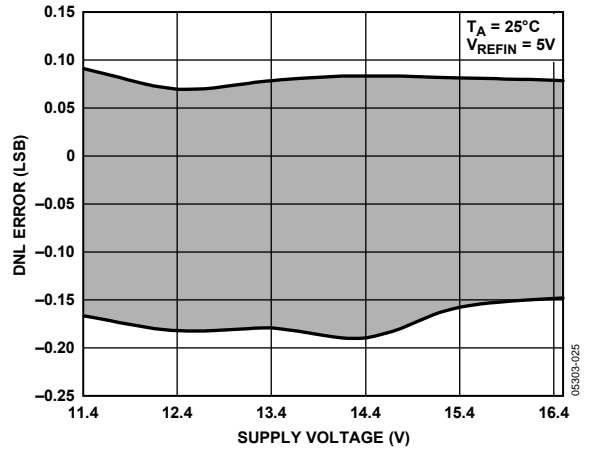

Figure 16. Differential Nonlinearity Error vs. Supply Voltage

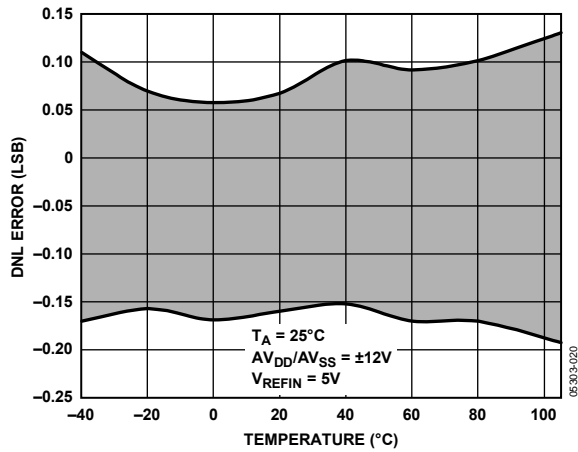

Figure 14. Differential Nonlinearity Error vs. Temperature, $AV_{DD}/AV_{SS} = \pm 12V$

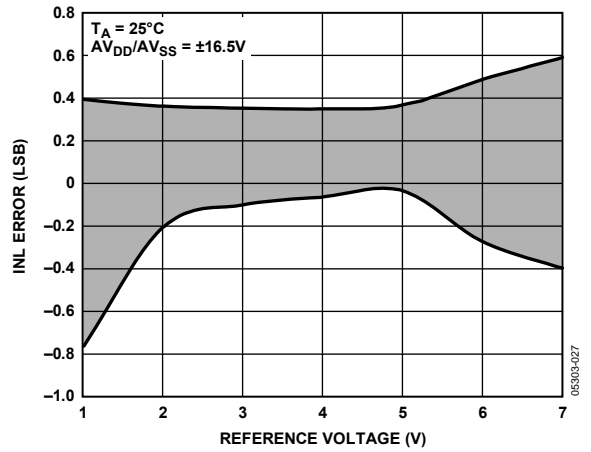

Figure 17. Integral Nonlinearity Error vs. Reference Voltage, $AV_{DD}/AV_{SS} = \pm 16.5V$

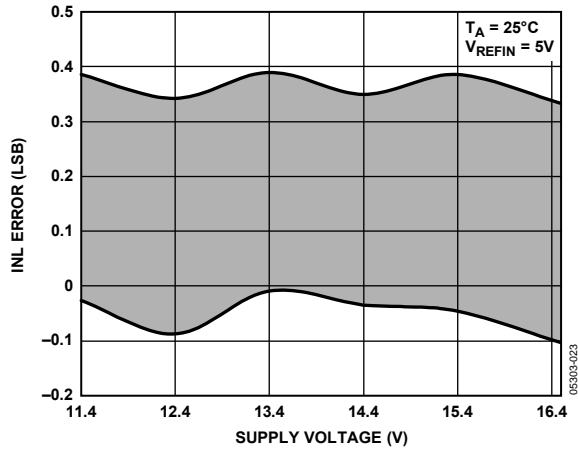

Figure 15. Integral Nonlinearity Error vs. Supply Voltage

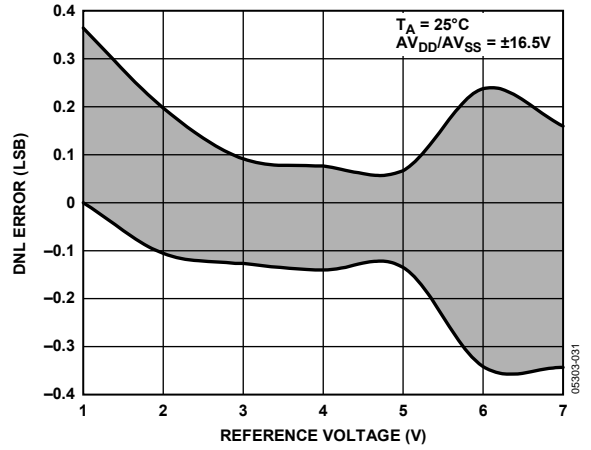

Figure 18. Differential Nonlinearity Error vs. Reference Voltage, $AV_{DD}/AV_{SS} = \pm 16.5V$

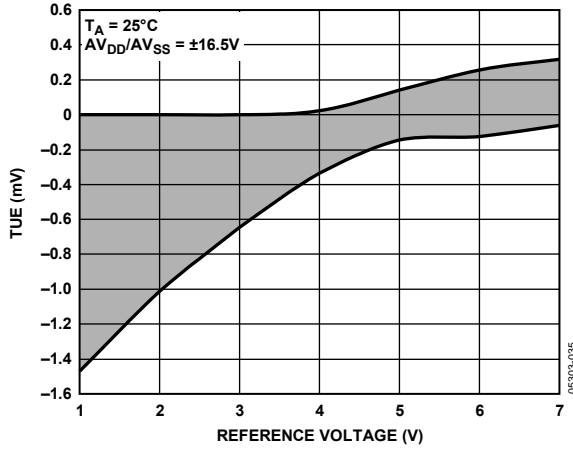

Figure 19. Total Unadjusted Error vs. Reference Voltage, $AV_{DD}/AV_{SS} = \pm 16.5V$

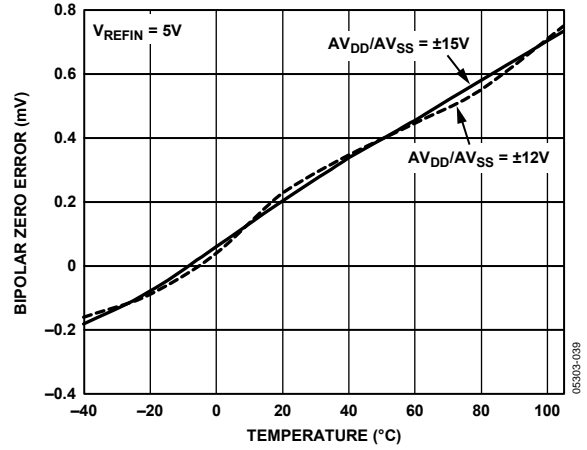

Figure 22. Bipolar Zero Error vs. Temperature

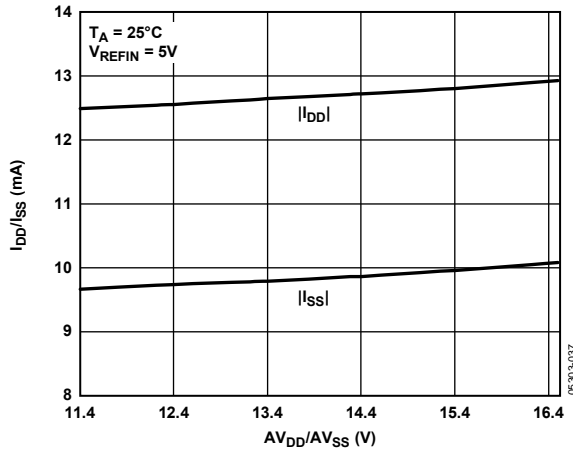

Figure 20. I_{DD}/I_{SS} vs. AV_{DD}/AV_{SS}

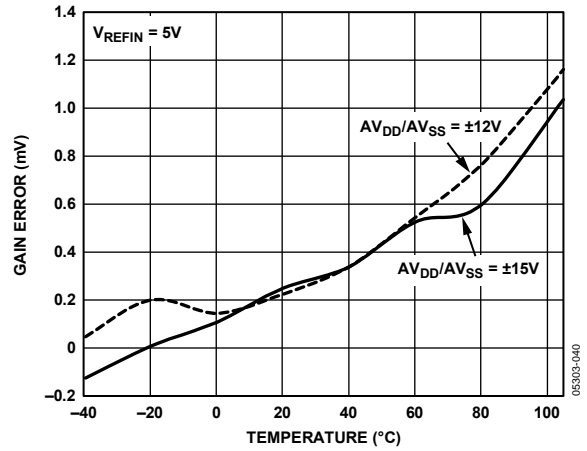

Figure 23. Gain Error vs. Temperature

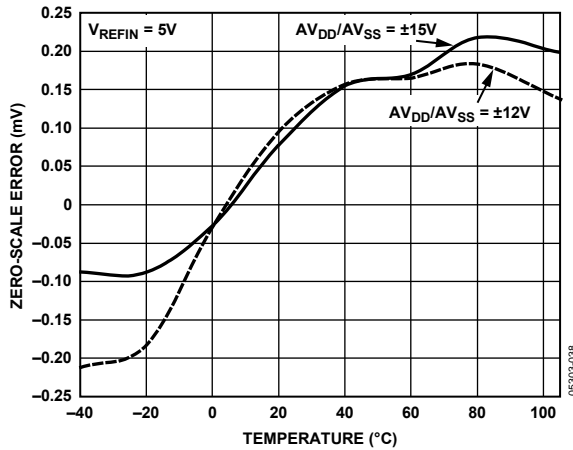

Figure 21. Zero-Scale Error vs. Temperature

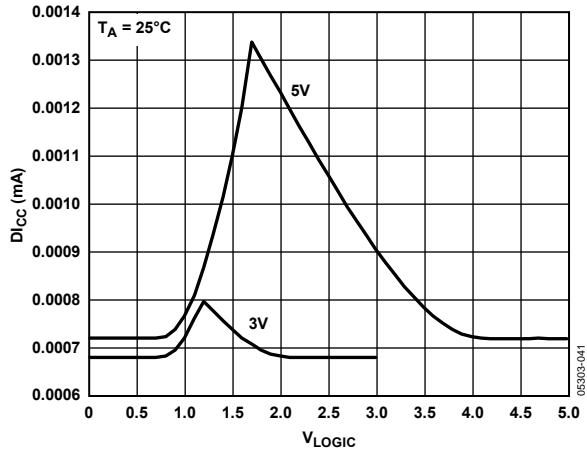

Figure 24. D_{ICC} vs. Logic Input Voltage

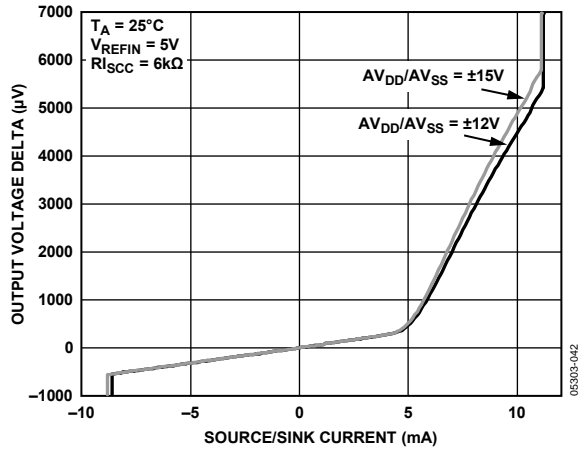

Figure 25. Source and Sink Capability of Output Amplifier with Positive Full Scale Loaded

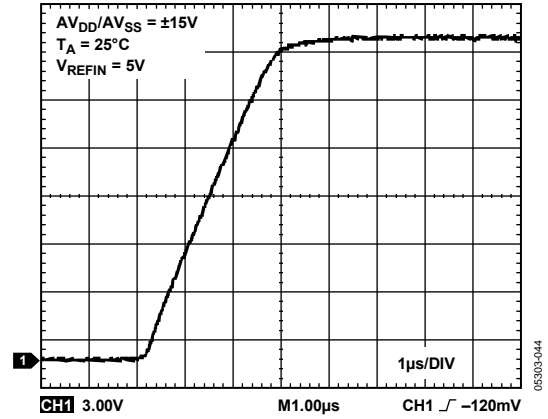

Figure 27. Full-Scale Settling Time

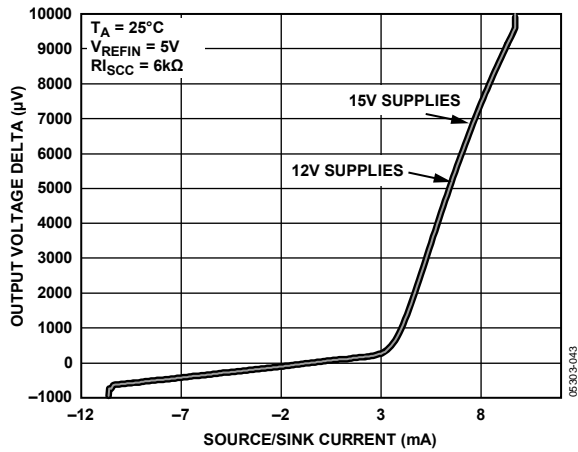

Figure 26. Source and Sink Capability of Output Amplifier with Negative Full Scale Loaded

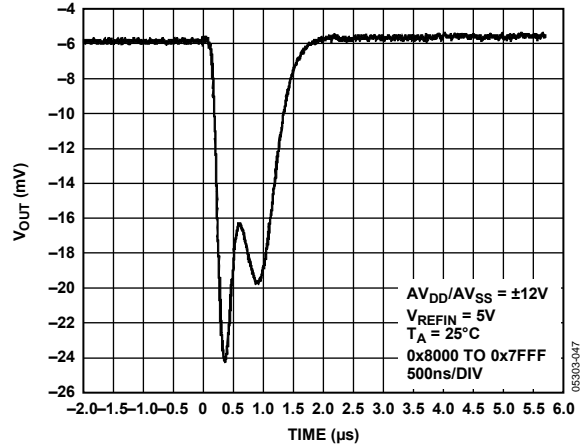

Figure 28. Major Code Transition Glitch Energy, $AV_{DD}/AV_{SS} = \pm 12\text{V}$

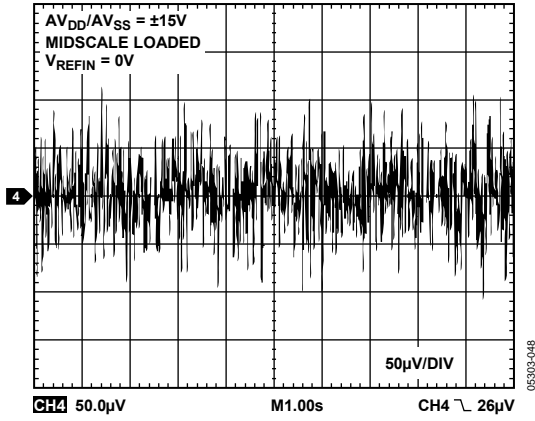

Figure 29. Peak-to-Peak Noise (100 kHz Bandwidth)

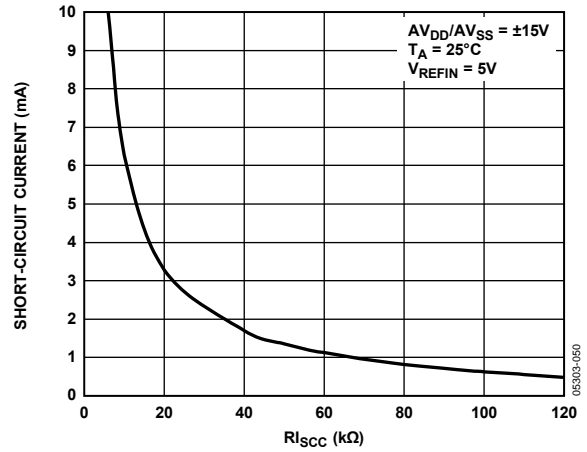

Figure 31. Short-Circuit Current vs. R_{LSCC}

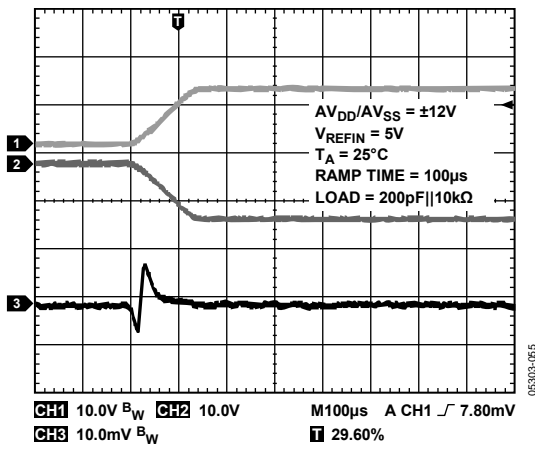

Figure 30. V_{OUT} vs. AV_{DD}/AV_{SS} on Power-Up

TERMINOLOGY

Relative Accuracy or Integral Nonlinearity (INL)

For the DAC, relative accuracy or integral nonlinearity (INL) is a measure of the maximum deviation, in LSBs, from a straight line passing through the endpoints of the DAC transfer function. A typical INL vs. code plot can be seen in Figure 7.

Differential Nonlinearity (DNL)

Differential nonlinearity is the difference between the measured change and the ideal 1 LSB change between any two adjacent codes. A specified differential nonlinearity of ± 1 LSB maximum ensures monotonicity. This DAC is guaranteed monotonic. A typical DNL vs. code plot can be seen in Figure 9.

Monotonicity

A DAC is monotonic if the output either increases or remains constant for increasing digital input code. The AD5764 is monotonic over its full operating temperature range.

Bipolar Zero Error

Bipolar zero error is the deviation of the analog output from the ideal half-scale output of 0 V when the data register is loaded with 0x8000 (offset binary coding) or 0x0000 (twos complement coding). A plot of bipolar zero error vs. temperature can be seen in Figure 22.

Bipolar Zero Temperature Coefficient (TC)

Bipolar zero TC is the measure of the change in the bipolar zero error with a change in temperature. It is expressed in ppm FSR/ $^{\circ}$ C.

Full-Scale Error

Full-scale error is a measure of the output error when full-scale code is loaded to the data register. Ideally, the output voltage should be $2 \times V_{REF} - 1$ LSB. Full-scale error is expressed in percentage of full-scale range.

Negative Full-Scale Error/Zero-Scale Error

Negative full-scale error is the error in the DAC output voltage when 0x0000 (offset binary coding) or 0x8000 (twos complement coding) is loaded to the data register. Ideally, the output voltage should be $-2 \times V_{REF}$. A plot of zero-scale error vs. temperature can be seen in Figure 21.

Output Voltage Settling Time

Output voltage settling time is the amount of time it takes for the output to settle to a specified level for a full-scale input change.

Slew Rate

The slew rate of a device is a limitation in the rate of change of the output voltage. The output slewing speed of a voltage-output DAC is usually limited by the slew rate of the amplifier used at its output. Slew rate is measured from 10% to 90% of the output signal and is given in V/ μ s.

Gain Error

Gain error is a measure of the span error of the DAC. It is the deviation in slope of the DAC transfer characteristic from the ideal, expressed as a percentage of the full-scale range. A plot of gain error vs. temperature can be seen in Figure 23.

Total Unadjusted Error

Total unadjusted error (TUE) is a measure of the output error considering all the various errors. A plot of total unadjusted error vs. reference voltage can be seen in Figure 19.

Zero-Scale Error Temperature Coefficient (TC)

Zero-scale error TC is a measure of the change in zero-scale error with a change in temperature. Zero-scale error TC is expressed in ppm FSR/ $^{\circ}$ C.

Gain Error Temperature Coefficient (TC)

Gain error TC is a measure of the change in gain error with changes in temperature. Gain error TC is expressed in ppm FSR/ $^{\circ}$ C.

Digital-to-Analog Glitch Energy

Digital-to-analog glitch impulse is the impulse injected into the analog output when the input code in the data register changes state. It is normally specified as the area of the glitch in nV-sec, and is measured when the digital input code is changed by 1 LSB at the major carry transition (0x7FFF to 0x8000); see Figure 28.

Digital Feedthrough

Digital feedthrough is a measure of the impulse injected into the analog output of the DAC from the digital inputs of the DAC but is measured when the DAC output is not updated. It is specified in nV-sec and measured with a full-scale code change on the data bus, that is, from all 0s to all 1s, and vice versa.

Power Supply Sensitivity

Power supply sensitivity indicates how the output of the DAC is affected by changes in the power supply voltage.

DC Crosstalk

DC crosstalk is the dc change in the output level of one DAC in response to a change in the output of another DAC. It is measured with a full-scale output change on one DAC while monitoring another DAC, and is expressed in LSBs.

DAC-to-DAC Crosstalk

DAC-to-DAC crosstalk is the glitch impulse transferred to the output of one DAC due to a digital code change and subsequent output change of another DAC. This includes both digital and analog crosstalk. It is measured by loading one of the DACs with a full-scale code change (all 0s to all 1s and vice versa) with LDAC low and monitoring the output of another DAC. The energy of the glitch is expressed in nV-sec.

Channel-to-Channel Isolation

Channel-to-channel isolation is the ratio of the amplitude of the signal at the output of one DAC to a sine wave on the reference input of another DAC. It is measured in dB.

Digital Crosstalk

Digital crosstalk is a measure of the impulse injected into the analog output of one DAC from the digital inputs of another DAC, but is measured when the DAC output is not updated. It is specified in nV-sec and measured with a full-scale code change on the data bus, that is, from all 0s to all 1s, and vice versa.

THEORY OF OPERATION

The AD5764 is a quad, 16-bit, serial input, bipolar voltage output DAC and operates from supply voltages of ± 11.4 V to ± 16.5 V and has a buffered output voltage of up to ± 10.5263 V. Data is written to the AD5764 in a 24-bit word format, via a 3-wire serial interface.

The device also offers an SDO pin that is available for daisy-chaining or readback.

The AD5764 incorporates a power-on reset circuit, which ensures that the data register powers up loaded with 0x0000. The AD5764 features a digital I/O port that can be programmed via the serial interface, on-chip reference buffers and per channel digital gain, and offset registers.

DAC ARCHITECTURE

The DAC architecture of the AD5764 consists of a 16-bit, current mode, segmented R-2R DAC. The simplified circuit diagram for the DAC section is shown in Figure 32.

The four MSBs of the 16-bit data word are decoded to drive 15 switches, E1 to E15. Each of these switches connects one of the 15 matched resistors to either AGNDx or IOUx. The remaining 12 bits of the data-word drive Switch S0 to Switch S11 of the 12-bit R-2R ladder network.

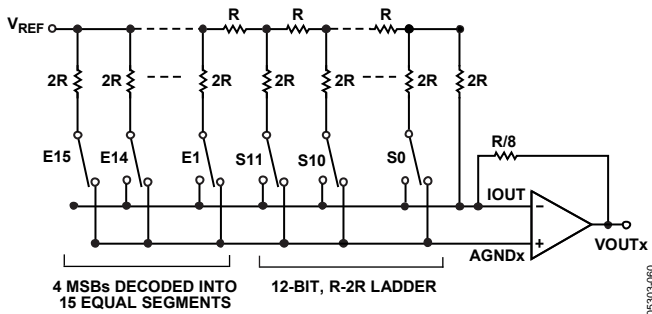

Figure 32. DAC Ladder Structure

REFERENCE BUFFERS

The AD5764 operates with an external reference. The reference inputs (REFAB and REFC) have an input range up to 7 V. This input voltage is used to provide a buffered positive and negative reference for the DAC cores. The positive reference is given by

$$+V_{REF} = 2 \times V_{REF}$$

The negative reference to the DAC cores is given by

$$-V_{REF} = -2 \times V_{REF}$$

These positive and negative reference voltages (along with the gain register values) define the output ranges of the DACs.

SERIAL INTERFACE

The AD5764 is controlled over a versatile 3-wire serial interface that operates at clock rates of up to 30 MHz and is compatible with SPI, QSPI™, MICROWIRE™, and DSP standards.

Input Shift Register

The input shift register is 24 bits wide. Data is loaded into the device MSB first as a 24-bit word under the control of a serial clock input, SCLK. The input shift register consists of a read/write bit, three register select bits, three DAC address bits, and 16 data bits, as shown in Table 9. The timing diagram for this operation is shown in Figure 2.

Upon power-up, the data register is loaded with zero code (0x0000), and the outputs are clamped to 0 V via a low impedance path. The outputs can be updated with the zero code value at this time by asserting either LDAC or CLR. The corresponding output voltage depends on the state of the BIN/2sCOMP pin. If the BIN/2sCOMP pin is tied to DGND, the data coding is twos complement, and the outputs update to 0 V. If the BIN/2sCOMP pin is tied to DVCC, the data coding is offset binary, and the outputs update to negative full scale. To power up the outputs with zero code loaded to the outputs, hold the CLR pin low during power-up.

Standalone Operation

The serial interface works with both a continuous and noncontinuous serial clock. A continuous SCLK source can only be used if SYNC is held low for the correct number of clock cycles. In gated clock mode, a burst clock containing the exact number of clock cycles must be used and SYNC must be taken high after the final clock to latch the data. The first falling edge of SYNC starts the write cycle. Exactly 24 falling clock edges must be applied to SCLK before SYNC is brought high again. If SYNC is brought high before the 24th falling SCLK edge, the data written is invalid. If more than 24 falling SCLK edges are applied before SYNC is brought high, the input data is also invalid. The input shift register addressed is updated on the rising edge of SYNC. For another serial transfer to take place, SYNC must be brought low again. After the end of the serial data transfer, data is automatically transferred from the input shift register to the addressed register.

When the data has been transferred into the chosen register of the addressed DAC, the data register and outputs can be updated by taking LDAC low.

Daisy-Chain Operation

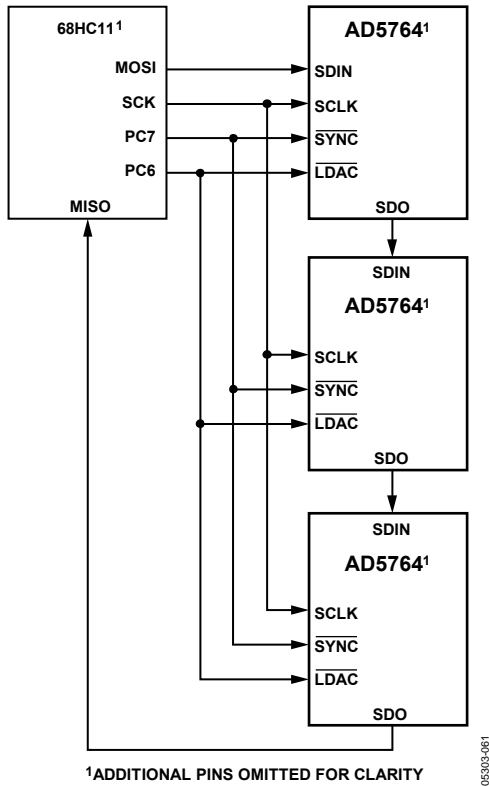

Figure 33. Daisy-Chaining the AD5764

For systems that contain several devices, the SDO pin can be used to daisy-chain several devices together. This daisy-chain mode can be useful in system diagnostics and in reducing the number of serial interface lines. The first falling edge of SYNC starts the write cycle. The SCLK is continuously applied to the input shift register when SYNC is low. If more than 24 clock pulses are applied, the data ripples out of the input shift register and appears on the SDO line. This data is clocked out on the rising edge of SCLK and is valid on the falling edge. By connecting the SDO of the first device to the SDIN input of the next device in the chain, a multidevice interface is constructed. Each device in the system requires 24 clock pulses. Therefore, the total number of clock cycles must equal 24N, where N is the total number of AD5764 devices in the chain. When the serial transfer to all devices is complete, SYNC is taken high. This latches the input data in each device in the daisy chain and prevents any further data from being clocked into the input shift register. The serial clock can be a continuous or a gated clock.

A continuous SCLK source can only be used if SYNC is held low for the correct number of clock cycles. In gated clock mode, a burst clock containing the exact number of clock cycles must be used, and SYNC must be taken high after the final clock to latch the data.

Readback Operation

Before a readback operation is initiated, the SDO pin must be enabled by writing to the function register and clearing the SDO

disable bit; this bit is cleared by default. Readback mode is invoked by setting the R/W bit = 1 in the serial input shift register write. With R/W = 1, Bit A2 to Bit A0, in association with Bit REG2, Bit REG1, and Bit REG0, select the register to be read. The remaining data bits in the write sequence are don't cares. During the next SPI write, the data appearing on the SDO output contain the data from the previously addressed register. For a read of a single register, the NOP command can be used in clocking out the data from the selected register on SDO. The readback diagram in Figure 4 shows the readback sequence. For example, to read back the fine gain register of Channel A on the AD5764, implement the following:

1. Write 0xA0XXXX to the AD5764 input shift register. This configures the AD5764 for read mode with the fine gain register of Channel A selected. Note that all the data bits, DB15 to DB0, are don't cares.
2. Follow this with a second write, an NOP condition, 0x00XXXX. During this write, the data from the fine gain register is clocked out on the SDO line, that is, data clocked out contain the data from the fine gain register in Bit DB5 to Bit DB0.

SIMULTANEOUS UPDATING VIA LDAC

Depending on the status of both SYNC and LDAC, and after data has been transferred into the input register of the DACs, there are two ways in which the data register and DAC outputs can be updated.

Individual DAC Updating

In this mode, LDAC is held low while data is being clocked into the input shift register. The addressed DAC output is updated on the rising edge of SYNC.

Simultaneous Updating of All DACs

In this mode, LDAC is held high while data is being clocked into the input shift register. All DAC outputs are updated by taking LDAC low any time after SYNC has been taken high. The update now occurs on the falling edge of LDAC.

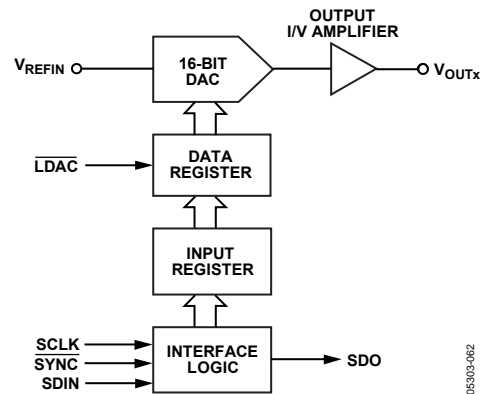

Figure 34. Simplified Serial Interface of Input Loading Circuitry for One DAC Channel

TRANSFER FUNCTION

Table 7 and Table 8 show the ideal input code to output voltage relationship for the AD5764 for both offset binary and twos complement data coding, respectively.

Table 7. Ideal Output Voltage to Input Code Relationship—Offset Binary Data Coding

Digital Input				Analog Output
MSB			LSB	VOUTx
1111	1111	1111	1111	+2 V _{REF} × (32,767/32,768)
1000	0000	0000	0001	+2 V _{REF} × (1/32,768)
1000	0000	0000	0000	0 V
0111	1111	1111	1111	−2 V _{REF} × (1/32,768)
0000	0000	0000	0000	−2 V _{REF} × (32,767/32,768)

Table 8. Ideal Output Voltage to Input Code Relationship—Twos Complement Data Coding

Digital Input				Analog Output
MSB			LSB	VOUTx
0111	1111	1111	1111	+2 V _{REF} × (32,767/32,768)
0000	0000	0000	0001	+2 V _{REF} × (1/32,768)
0000	0000	0000	0000	0 V
1111	1111	1111	1111	−2 V _{REF} × (1/32,768)
1000	0000	0000	0000	−2 V _{REF} × (32,767/32,768)

Table 9. Input Shift Register Bit Map

MSB								LSB
DB23	DB22	DB21	DB20	DB19	DB18	DB17	DB16	DB15:DB0
R/W	0	REG2	REG1	REG0	A2	A1	A0	Data

Table 10. Input Shift Register Bit Functions

Bit	Description			
R/W	Indicates a read from or a write to the addressed register.			
REG2, REG1, REG0	Used in association with the address bits to determine if a read or write operation is to the data register, offset register, coarse gain register, fine gain register, or function register.			
	REG2	REG1	REG0	Function
	0	0	0	Function register
	0	1	0	Data register
	0	1	1	Coarse gain register
	1	0	0	Fine gain register
	1	0	1	Offset register
A2, A1, A0	These bits are used to decode the DAC channels.			
	A2	A1	A0	Channel Address
	0	0	0	DAC A
	0	0	1	DAC B
	0	1	0	DAC C
	0	1	1	DAC D
	1	0	0	All DACs
Data	Data bits.			

The output voltage expression for the AD5764 is given by

$$V_{OUT} = -2 \times V_{REFIN} + 4 \times V_{REFIN} \left[\frac{D}{65,536} \right]$$

where:

D is the decimal equivalent of the code loaded to the DAC.

V_{REFIN} is the reference voltage applied at the REFAB/REFCD pins.

ASYNCHRONOUS CLEAR (CLR)

$\overline{\text{CLR}}$ is a negative edge triggered clear that allows the outputs to be cleared to either 0 V (twos complement coding) or negative full scale (offset binary coding). It is necessary to maintain $\overline{\text{CLR}}$ low for a minimum amount of time (see Figure 2) for the operation to complete. When the $\overline{\text{CLR}}$ signal is returned high, the output remains at the cleared value until a new value is programmed. If at power-on, $\overline{\text{CLR}}$ is at 0 V, then all DAC outputs are updated with the clear value. A clear can also be initiated through software by writing Command 0x04XXXX to the AD5764.

FUNCTION REGISTER

The function register is addressed by setting the three REG bits to 000. The values written to the address bits and the data bits determine the function addressed. The functions available via the function register are outlined in Table 11 and Table 12.

Table 11. Function Register Options

REG2	REG1	REG0	A2	A1	A0	DB15:DB6	DB5	DB4	DB3	DB2	DB1	DB0
0	0	0	0	0	0	NOP, data = don't care						
0	0	0	0	0	1	Don't care	Local ground offset adjust	D1 direction	D1 value	D0 direction	D0 value	SDO disable
0	0	0	1	0	0	Clear, data = don't care						
0	0	0	1	0	1	Load, data = don't care						

Table 12. Explanation of Function Register Options

Option	Description
NOP	No operation instruction used in readback operations.
Local Ground Offset Adjust	Set by the user to enable the local ground offset adjust function. Cleared by the user to disable the local ground offset adjust function (default). Refer to the Design Features section for further details.
D0/D1 Direction	Set by the user to enable D0/D1 as outputs. Cleared by the user to enable D0/D1 as inputs (default). Refer to the Design Features section for further details.
D0/D1 Value	I/O port status bits. Logic values written to these locations determine the logic outputs on the D0 and D1 pins when configured as outputs. These bits indicate the status of the D0 and D1 pins when the I/O port is active as an input. When enabled as inputs, these bits are don't cares during a write operation.
SDO Disable	Set by the user to disable the SDO output. Cleared by the user to enable the SDO output (default).
Clear	Addressing this function resets the DAC outputs to 0 V in twos complement mode and negative full scale in binary mode.
Load	Addressing this function updates the data register and consequently the analog outputs.

DATA REGISTER

The data register is addressed by setting the three REG bits to 010. The DAC address bits select with which DAC channel the data transfer is to take place (see Table 10). The data bits are in Position DB15 to Position DB0, as shown in Table 13.

Table 13. Programming the Data Register Bit Map

REG2	REG1	REG0	A2	A1	A0	DB15:DB0
0	1	0	DAC address			16-bit DAC data

COARSE GAIN REGISTER

The coarse gain register is addressed by setting the three REG bits to 011. The DAC address bits select with which DAC channel the data transfer is to take place (see Table 10). The coarse gain register is a 2-bit register and allows the user to select the output range of each DAC, as shown in Table 14 and Table 15.

Table 14. Programming the Coarse Gain Register Bit Map

REG2	REG1	REG0	A2	A1	A0	DB15:DB2	DB1	DB0
0	1	1	DAC address			Don't care	CG1	CG0

Table 15. Output Range Selection

Output Range	CG1	CG0
±10 V (Default)	0	0
±10.2564 V	0	1
±10.5263 V	1	0

FINE GAIN REGISTER

The fine gain register is addressed by setting the three REG bits to 100. The DAC address bits select with which DAC channel the data transfer is to take place (see Table 10). The fine gain register is a 6-bit register and allows the user to adjust the gain of each DAC channel by -32 LSBs to $+31$ LSBs in 1 LSB increments, as shown in Table 16 and Table 17. The adjustment is made to both the positive full-scale points and the negative full-scale points simultaneously, each point being adjusted by $\frac{1}{2}$ of one step. The fine gain register coding is twos complement.

OFFSET REGISTER

The offset register is addressed by setting the three REG bits to 101. The DAC address bits select with which DAC channel the data transfer is to take place (see Table 10). The AD5764 offset register is an 8-bit register and allows the user to adjust the offset of each channel by -16 LSBs to $+15.875$ LSBs in increments of $\frac{1}{8}$ LSB, as shown in Table 18 and Table 19. The offset register coding is twos complement.

Table 16. Programming the Fine Gain Register Bit Map

REG2	REG1	REG0	A2	A1	A0	DB15:DB6	DB5	DB4	DB3	DB2	DB1	DB0
1	0	0	DAC address			Don't care	FG5	FG4	FG3	FG2	FG1	FG0

Table 17. Fine Gain Register Options

Gain Adjustment	FG5	FG4	FG3	FG2	FG1	FG0
+31 LSBs	0	1	1	1	1	1
+30 LSBs	0	1	1	1	1	0
...
+2 LSBs	0	0	0	0	1	0
+1 LSB	0	0	0	0	0	1
No Adjustment (Default)	0	0	0	0	0	0
-1 LSB	1	1	1	1	1	1
-2 LSBs	1	1	1	1	1	0
...
-31 LSBs	1	0	0	0	0	1
-32 LSBs	1	0	0	0	0	0

Table 18. Programming the Offset Register Bit Map

REG2	REG1	REG0	A2	A1	A0	DB15:DB8	DB7	DB6	DB5	DB4	DB3	DB2	DB1	DB0
1	0	1	DAC address			Don't care	OF7	OF6	OF5	OF4	OF3	OF2	OF1	OF0

Table 19. AD5764 Offset Register Options

Offset Adjustment	OF7	OF6	OF5	OF4	OF3	OF2	OF1	OF0
+15.875 LSBs	0	1	1	1	1	1	1	1
+15.75 LSBs	0	1	1	1	1	1	1	0
...
+0.25 LSBs	0	0	0	0	0	0	1	0
+0.125 LSBs	0	0	0	0	0	0	0	1
No Adjustment (Default)	0	0	0	0	0	0	0	0
-0.125 LSBs	1	1	1	1	1	1	1	1
-0.25 LSBs	1	1	1	1	1	1	1	0
...
-15.875 LSBs	1	0	0	0	0	0	0	1
-16 LSBs	1	0	0	0	0	0	0	0

OFFSET AND GAIN ADJUSTMENT WORKED EXAMPLE

Using the information provided in the Fine Gain Register and Offset Register sections, the following worked example demonstrates how the AD5764 functions can be used to eliminate both offset and gain errors. Because the AD5764 is factory calibrated, offset and gain errors should be negligible. However, errors can be introduced by the system that the AD5764 is operating within; for example, a voltage reference value that is not equal to 5 V introduces a gain error. An output range of ± 10 V and twos complement data coding is assumed.

Removing Offset Error

The AD5764 can eliminate an offset error in the range of -4.88 mV to $+4.84$ mV with a step size of $\frac{1}{8}$ of a 16-bit LSB.

Calculate the step size of the offset adjustment.

$$\text{Offset Adjust Step Size} = \frac{20}{2^{16} \times 8} = 38.14 \mu\text{V}$$

Measure the offset error by programming 0x0000 to the data register and measuring the resulting output voltage. For this example, the measured value is $614 \mu\text{V}$.

Calculate the number of offset adjustment steps that this value represents.

$$\text{Number of Steps} = \frac{\text{Measured Offset Value}}{\text{Offset Step Size}} = \frac{614 \mu\text{V}}{38.14 \mu\text{V}} = 16 \text{ Steps}$$

The offset error measured is positive, therefore, a negative adjustment of 16 steps is required. The offset register is eight bits wide and the coding is twos complement. The required offset register value can be calculated as follows:

Convert the adjustment value to binary: 00010000.

Convert this to a negative twos complement number by inverting all bits and adding 1 to obtain 11110000, the value that should be programmed to the offset register.

Note that this twos complement conversion is not necessary in the case of a positive offset adjustment. The value to be programmed to the offset register is simply the binary representation of the adjustment value.

Removing Gain Error

The AD5764 can eliminate a gain error at negative full-scale output in the range of -9.77 mV to $+9.46$ mV with a step size of $\frac{1}{2}$ of a 16-bit LSB.

Calculate the step size of the gain adjustment.

$$\text{Gain Adjust Step Size} = \frac{20}{2^{16} \times 2} = 152.59 \mu\text{V}$$

Measure the gain error by programming 0x8000 to the data register and measuring the resulting output voltage. The gain error is the difference between this value and -10 V. For this example, the gain error is -1.2 mV.

Calculate how many gain adjustment steps this value represents.

$$\text{Number of Steps} = \frac{\text{Measured Gain Value}}{\text{Gain Step Size}} = \frac{1.2 \text{ mV}}{152.59 \mu\text{V}} = 8 \text{ Steps}$$

The gain error measured is negative (in terms of magnitude); therefore, a positive adjustment of eight steps is required. The gain register is 6 bits wide and the coding is twos complement, the required gain register value can be determined as follows:

Convert the adjustment value to binary: 001000.

The value to be programmed to the gain register is simply this binary number.

DESIGN FEATURES

ANALOG OUTPUT CONTROL

In many industrial process control applications, it is vital that the output voltage be controlled during power-up and during brownout conditions. When the supply voltages are changing, the VOUTx pins are clamped to 0 V via a low impedance path. To prevent the output amp being shorted to 0 V during this time, Transmission Gate G1 is also opened (see Figure 35). These conditions are maintained until the power supplies stabilize and a valid word is written to the data register. At this time, G2 opens and G1 closes. Both transmission gates are also externally controllable via the reset logic (RSTIN) control input. For instance, if RSTIN is driven from a battery supervisor chip, the $\overline{\text{RSTIN}}$ input is driven low to open G1 and close G2 upon power-down or during a brownout. Conversely, the on-chip voltage detector output (RSTOUT) is also available to the user to control other parts of the system. The basic transmission gate functionality is shown in Figure 35.

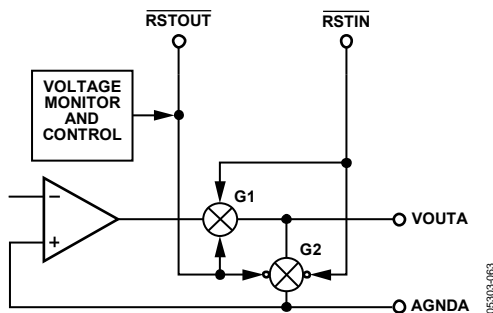

Figure 35. Analog Output Control Circuitry

DIGITAL OFFSET AND GAIN CONTROL

The AD5764 incorporates a digital offset adjust function with a ± 16 LSB adjust range and 0.125 LSB resolution. The coarse gain register allows the user to adjust the AD5764 full-scale output range. The full-scale output can be programmed to achieve full-scale ranges of ± 10 V, ± 10.2564 V, and ± 10.5263 V. A fine gain trim is also provided.

PROGRAMMABLE SHORT-CIRCUIT PROTECTION

The short-circuit current of the output amplifiers can be programmed by inserting an external resistor between the ISCC pin and PGND. The programmable range for the current is 500 μA to 10 mA, corresponding to a resistor range of 120 k Ω to 6 k Ω . The resistor value is calculated as follows:

$$R = \frac{60}{I_{SC}}$$

If the ISCC pin is left unconnected, the short-circuit current limit defaults to 5 mA. Note that limiting the short-circuit current to a small value can affect the slew rate of the output when driving into a capacitive load; therefore, the value of the programmed short circuit should take into account the size of the capacitive load being driven.

DIGITAL I/O PORT

The AD5764 contains a 2-bit digital I/O port (D1 and D0). These bits can be configured as inputs or outputs independently, and can be driven or have their values read back via the serial interface. The I/O port signals are referenced to DV_{CC} and DGND. When configured as outputs, they can be used as control signals to multiplexers or can be used to control calibration circuitry elsewhere in the system. When configured as inputs, the logic signals from limit switches can, for example, be applied to D0 and D1 and can be read back via the digital interface.

LOCAL GROUND OFFSET ADJUST

The AD5764 incorporates a local ground offset adjust feature that, when enabled in the function register, adjusts the DAC outputs for voltage differences between the individual DAC ground pins, AGNDx, and the REFGND pin, ensuring that the DAC output voltages are always with respect to the local DAC ground pin. For instance, if Pin AGNDA is at +5 mV with respect to the REFGND pin and VOUTA is measured with respect to AGNDA, a -5 mV error results, enabling the local ground offset adjust feature to adjust VOUTA by +5 mV, eliminating the error.

APPLICATIONS INFORMATION

TYPICAL OPERATING CIRCUIT

Figure 36 shows the typical operating circuit for the AD5764. The only external components needed for this precision 16-bit DAC are a reference voltage source, decoupling capacitors on the supply pins and reference inputs, and an optional short-circuit current setting resistor. Because the device incorporates reference buffers, it eliminates the need for an external bipolar

reference and associated buffers. This leads to an overall savings in both cost and board space.

In Figure 36, AV_{DD} is connected to +15 V and AV_{SS} is connected to -15 V. However, AV_{DD} can operate with supplies from +11.4 V to +16.5 V and AV_{SS} can operate with supplies from -11.4 V to -16.5 V.

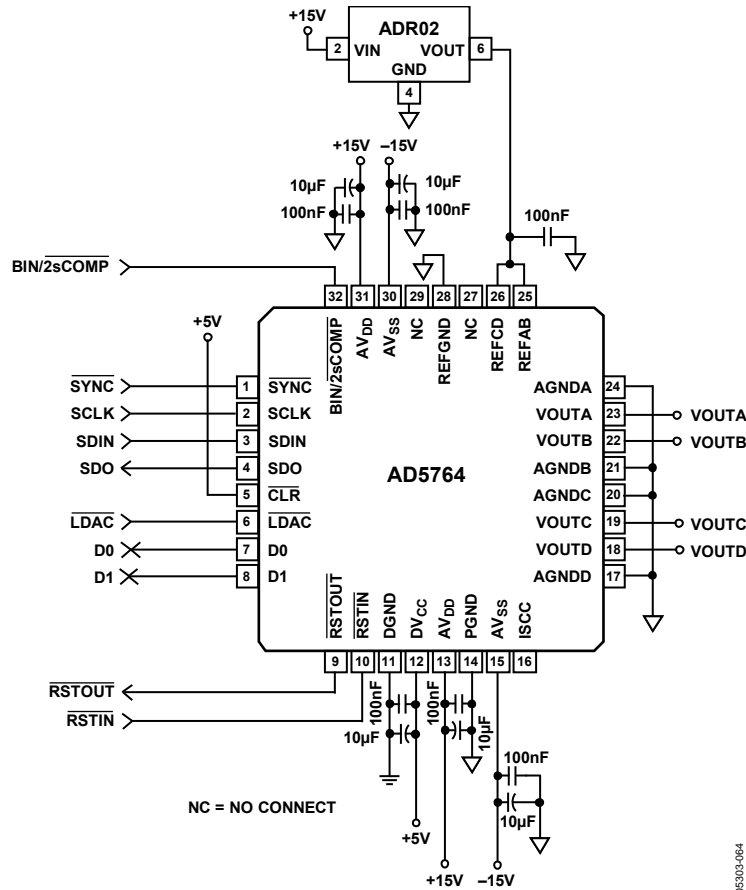

Figure 36. Typical Operating Circuit

05303-064

Precision Voltage Reference Selection

To achieve the optimum performance from the AD5764 over its full operating temperature range, a precision voltage reference must be used. Consideration should be given to the selection of a precision voltage reference. The AD5764 has two reference inputs, REFAB and REFC. The voltages applied to the reference inputs are used to provide a buffered positive and negative reference for the DAC cores. Therefore, any error in the voltage reference is reflected in the outputs of the device.

There are four possible sources of error to consider when choosing a voltage reference for high accuracy applications: initial accuracy, temperature coefficient of the output voltage, long-term drift, and output voltage noise.

Initial accuracy error on the output voltage of an external reference can lead to a full-scale error in the DAC. Therefore, to minimize these errors, a reference with low initial accuracy error specification is preferred. Choosing a reference with an output trim adjustment, such as the [ADR425](#), allows a system designer to trim system errors out by setting the reference

voltage to a voltage other than the nominal. The trim adjustment can also be used at temperature to trim out any error.

Long-term drift is a measure of how much the reference output voltage drifts over time. A reference with a tight long-term drift specification ensures that the overall solution remains relatively stable over its entire lifetime.

The temperature coefficient of a reference output voltage affects INL, DNL, and TUE. Choose a reference with a tight temperature coefficient specification to reduce the dependence of the DAC output voltage on ambient conditions.

In high accuracy applications, which have a relatively low noise budget, reference output voltage noise needs to be considered. Choosing a reference with as low an output noise voltage as practical for the system resolution required is important. Precision voltage references such as the [ADR435](#) (XFET® design) produce low output noise in the 0.1 Hz to 10 Hz region. However, as the circuit bandwidth increases, filtering the output of the reference may be required to minimize the output noise.

Table 20. Some Precision References Recommended for Use with the AD5764

Part No.	Initial Accuracy (mV Max)	Long-Term Drift (ppm Typ)	Temp Drift (ppm/°C Max)	0.1 Hz to 10 Hz Noise (μV p-p Typ)
ADR435	±2	40	3	8
ADR425	±2	50	3	3.4
ADR02	±5	50	3	10
ADR395	±5	50	9	8

LAYOUT GUIDELINES

In any circuit where accuracy is important, careful consideration of the power supply and ground return layout helps to ensure the rated performance. The PCB on which the AD5764 is mounted must be designed so that the analog and digital sections are separated and confined to certain areas of the board. If the AD5764 is in a system where multiple devices require an AGND-to-DGND connection, the connection is to be made at one point only. The star ground point is established as close as possible to the device. The AD5764 must have ample supply bypassing of 10 μF in parallel with 0.1 μF on each supply, located as close to the package as possible, ideally right up against the device. The 10 μF capacitors are the tantalum bead type. The 0.1 μF capacitor must have low effective series resistance (ESR) and low effective series inductance (ESI), such as the common ceramic types, which provide a low impedance path to ground at high frequencies to handle transient currents due to internal logic switching.

The power supply lines of the AD5764 must be as large a trace as possible to provide low impedance paths and reduce the effects of glitches on the power supply line. Fast switching signals, such as clocks, must be shielded with digital ground to avoid radiating noise to other parts of the board, and must never be run near the reference inputs. A ground line routed between the SDIN and SCLK lines helps reduce crosstalk between them (not required on a multilayer board, which has a separate ground plane; however, it is helpful to separate the lines). It is essential to minimize noise on the reference inputs because it couples through to the DAC output. Avoid crossover of digital and analog signals. Traces on opposite sides of the board must run at right angles to each other. This reduces the effects of feedthrough on the board. A microstrip technique is recommended, but not always possible with a double-sided board. In this technique, the component side of the board is dedicated to the ground plane, and signal traces are placed on the solder side.

GALVANICALLY ISOLATED INTERFACE

In many process control applications, it is necessary to provide an isolation barrier between the controller and the unit being controlled to protect and isolate the controlling circuitry from any hazardous common-mode voltages that may occur. Isocouplers provide voltage isolation in excess of 2.5 kV. The serial loading structure of the AD5764 makes it ideal for isolated

interfaces because the number of interface lines is kept to a minimum. Figure 37 shows a 4-channel isolated interface to the AD5764 using an ADuM1400. For more information, go to www.analog.com.

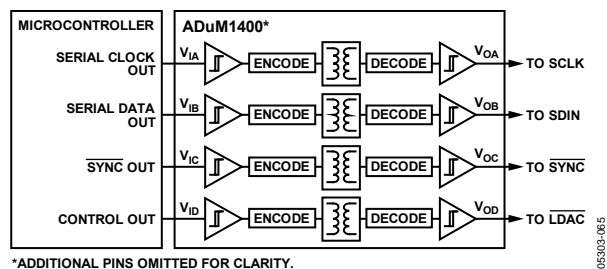

Figure 37. Isolated Interface

MICROPROCESSOR INTERFACING

Microprocessor interfacing to the AD5764 is via a serial bus that uses a standard protocol that is compatible with microcontrollers and DSP processors. The communications channel is a 3-wire (minimum) interface consisting of a clock signal, a data signal, and a synchronization signal. The AD5764 requires a 24-bit data-word with data valid on the falling edge of SCLK.

For all the interfaces, the DAC output update can be performed automatically when all the data is clocked in, or it can be done under the control of LDAC. The contents of the data register can be read using the readback function.

EVALUATION BOARD

The AD5764 comes with a full evaluation board to aid designers in evaluating the high performance of the part with minimum effort. All that is required with the evaluation board is a power supply and a PC. The AD5764 evaluation kit includes a populated, tested AD5764 PCB. The evaluation board interfaces to the USB port of the PC. Software is available with the evaluation board, which allows the user to easily program the AD5764. The software runs on any PC that has Microsoft® Windows® 2000/NT/XP installed.

The [EVAL-AD5764EB](#) data sheet is available, which gives full details on the operation of the evaluation board.

OUTLINE DIMENSIONS

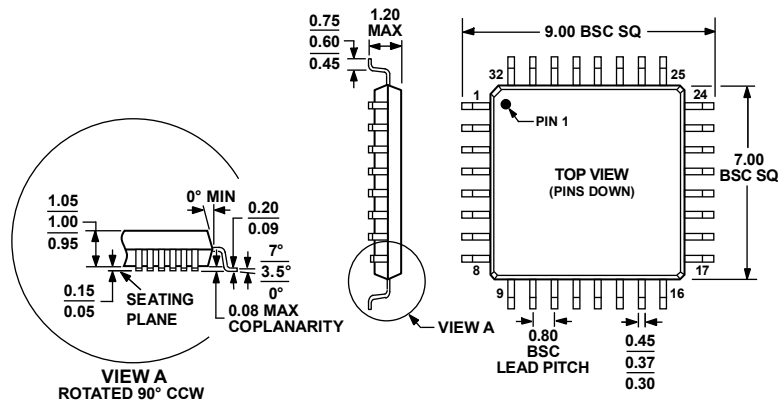

COMPLIANT TO JEDEC STANDARDS MS-026-ABA

Figure 38. 32-Lead Thin Plastic Quad Flat Package [TQFP] (SU-32-2)

Dimensions shown in millimeters

020607-A

ORDERING GUIDE

Model ¹	INL	Temperature Range	Package Description	Package Option
AD5764ASUZ	±4 LSB max	-40°C to +85°C	32-Lead TQFP	SU-32-2
AD5764ASUZ-REEL7	±4 LSB max	-40°C to +85°C	32-Lead TQFP	SU-32-2
AD5764BSUZ	±2 LSB max	-40°C to +85°C	32-Lead TQFP	SU-32-2
AD5764BSUZ-REEL7	±2 LSB max	-40°C to +85°C	32-Lead TQFP	SU-32-2
AD5764CSUZ	±1 LSB max	-40°C to +85°C	32-Lead TQFP	SU-32-2
AD5764CSUZ-REEL7	±1 LSB max	-40°C to +85°C	32-Lead TQFP	SU-32-2
EVAL-AD5764EBZ			Evaluation Board	

¹ Z = RoHS Compliant Part.



Компания «ЭлектроПласт» предлагает заключение долгосрочных отношений при поставках импортных электронных компонентов на взаимовыгодных условиях!

Наши преимущества:

- Оперативные поставки широкого спектра электронных компонентов отечественного и импортного производства напрямую от производителей и с крупнейших мировых складов;
- Поставка более 17-ти миллионов наименований электронных компонентов;
- Поставка сложных, дефицитных, либо снятых с производства позиций;
- Оперативные сроки поставки под заказ (от 5 рабочих дней);
- Экспресс доставка в любую точку России;
- Техническая поддержка проекта, помощь в подборе аналогов, поставка прототипов;
- Система менеджмента качества сертифицирована по Международному стандарту ISO 9001;
- Лицензия ФСБ на осуществление работ с использованием сведений, составляющих государственную тайну;
- Поставка специализированных компонентов (Xilinx, Altera, Analog Devices, Intersil, Interpoint, Microsemi, Aeroflex, Peregrine, Syfer, Eurofarad, Texas Instrument, Miteq, Cobham, E2V, MA-COM, Hittite, Mini-Circuits, General Dynamics и др.);

Помимо этого, одним из направлений компании «ЭлектроПласт» является направление «Источники питания». Мы предлагаем Вам помощь Конструкторского отдела:

- Подбор оптимального решения, техническое обоснование при выборе компонента;
- Подбор аналогов;
- Консультации по применению компонента;
- Поставка образцов и прототипов;
- Техническая поддержка проекта;
- Защита от снятия компонента с производства.



Как с нами связаться

Телефон: 8 (812) 309 58 32 (многоканальный)

Факс: 8 (812) 320-02-42

Электронная почта: org@eplast1.ru

Адрес: 198099, г. Санкт-Петербург, ул. Калинина, дом 2, корпус 4, литера А.