

Tous droits strictement réservés. Reproduction ou communication a des tiers interdite sous quelque forme que ce soit sans autorisation écrite du propriétaire. Propriété de c FCI. Droits de reproduction FCI.

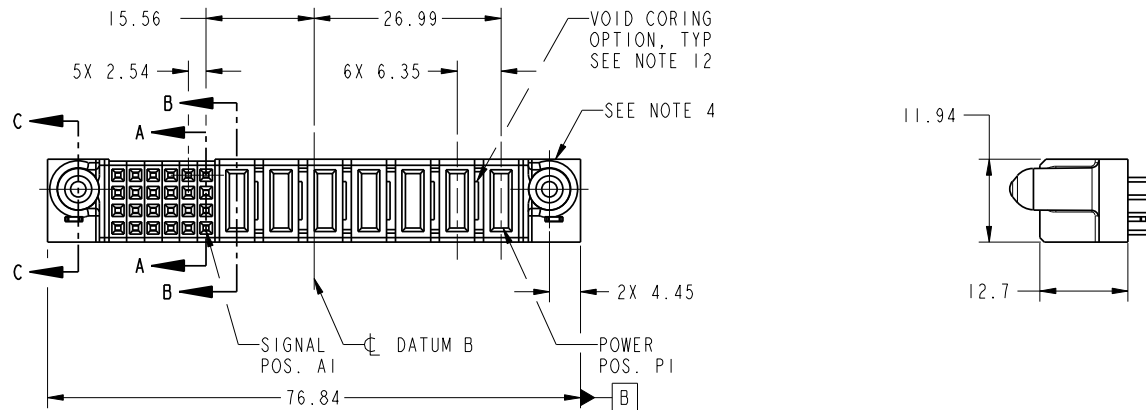

All rights strictly reserved. Reproduction or issue to third parties in any form whatever is not permitted without written authority from the proprietor. Property of FCI. Copyright FCI.

PRODUCT NO.	ROWS	SIGNAL					POWER					E1				
		E2	6	5	4	3	2	1	P7	P6	P5		P4	P3	P2	P1
51752-025-- NOTE: 3	D C B A		E	E	E	E	E	PA	PA	PA	PA	PA	PA	PA	PA	
		E	E	E	E	E	PA	PA	PA	PA	PA	PA	PA	PA	E	
		E	E	E	E	E	PA	PA	PA	PA	PA	PA	PA	PA	E	
		E	E	E	E	E	PA	PA	PA	PA	PA	PA	PA	PA	E	



CODE	DIM "M" MATING LENGTH	CONTACT TYPE
E	[N/A]	SIGNAL
PA	[1.07]	POWER
HA	[N/A]	HOLD-DOWN

mat'l code				tolerances unless otherwise specified		CUSTOMER	
SEE NOTES				0.X ±0.5		FCI www.fciconnect.com	
lfr	ecn no.	dr	date	linear	0.XX ±0.25	COPY	
A	DG08-0119	JC	05/20/08	angles	0.XXX ±0.1	projection	title
				dr	0° ±2°		7P + 24S VERTICAL SOLDER RECEPT
				engr		MM	product family
				chr		scale	PwrBlade
				appd		1:1	code
sheet index	revision sheet	A	A	A	A	A	size
1	2	3	4				dwg no
							51752-025
							sheet
							1 of 4



www.fciconnect.com

MM

1:1

projection

scale

size

code

sheet

1 of 4

Pro/E

cage code 22526

PDM: Rev:A

STATUS: Released

Printed: Dec 20, 2010

Tous droits strictement reserves. Reproduction ou communication a des tiers interdite sous quelque forme que ce soit sans autorisation écrite du propriétaire. Propriete de c FCI. Droits de reproduction FCI.



All rights strictly reserved. Reproduction or issue to third parties in any form whatever is not permitted without written authority from the proprietor. Property of FCI. Copyright FCI.

PRODUCT NUMBER  
51752-025...  
NOTE: 3

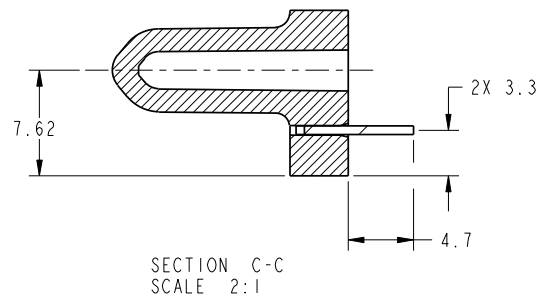
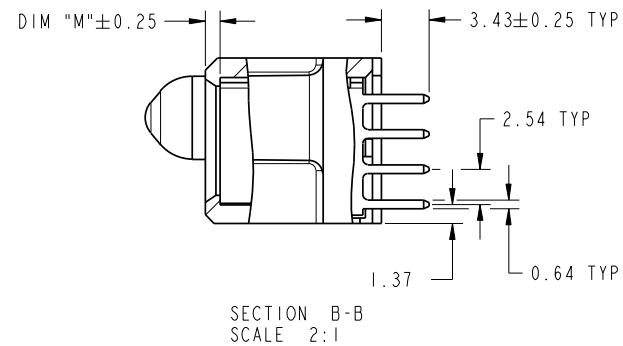
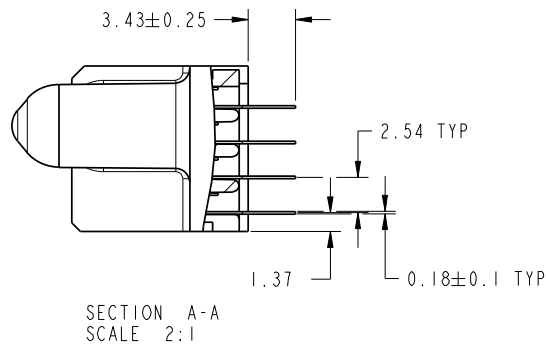

mat'l code				tolerances unless otherwise specified		CUSTOMER		FCI	
ltr	ecn no.	dr	date	linear	0.X ±0.5	COPY		www.fciconnect.com	
A				linear	0.XX ±0.25	projection	title		
				angles	0.XXX ±0.1		7P + 24S		
				dr	0° ±2°		VERTICAL SOLDER RECEPT		
				engr	Jerome Chen 04/17/08	MM	product family	PwrBlade	code
				chr	Jerome Chen 04/17/08	1:1	size	dwg no	213
				appd	Gary Hsieh 04/17/08		A	51752-025	sheet
					Joseph Hsia 04/17/08				2 of 4
sheet index	revision sheet								

Pro/E

cage code 22526

PDM: Rev:A

STATUS: Released

Printed: Dec 20, 2010

Tous droits strictement réservés. Reproduction ou communication o des liens interdite sous quelque forme que ce soit sans autorisation écrite du propriétaire. Propriete de c FCI. Droits de reproduction FCI.



All rights strictly reserved. Reproduction or issue to third parties in any form whatever is not permitted without written authority from the proprietor. Property of FCI. Copyright FCI.

PRODUCT NUMBER  
51752-025...  
NOTE: 3

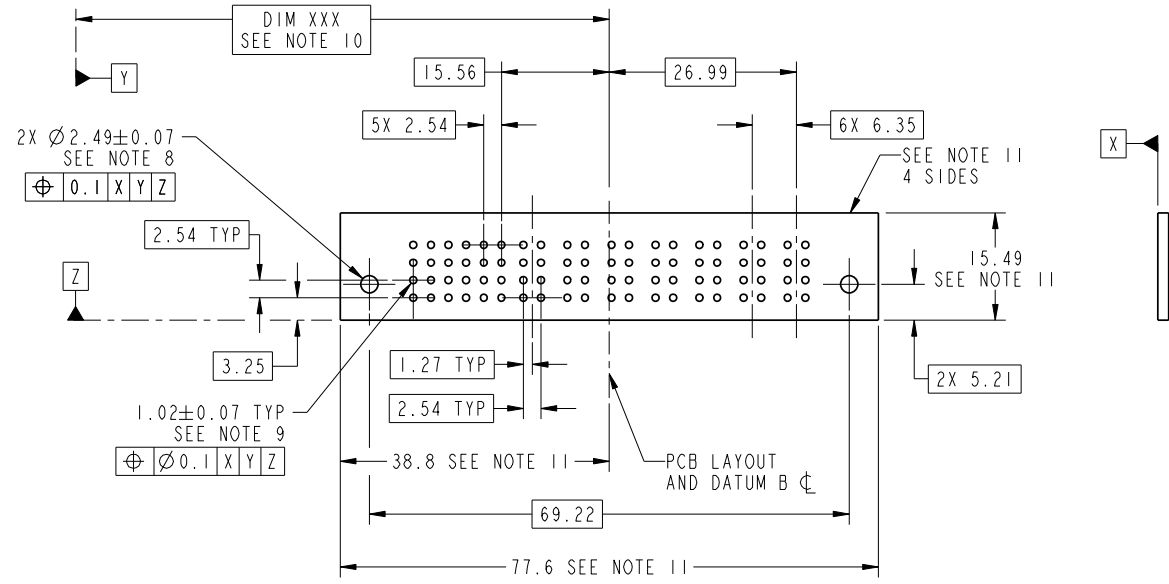

RECOMMENDED PCY LAYOUT

mat'l code				tolerances unless otherwise specified		CUSTOMER		FCI	
lfr	ecn no.	dr	date	linear	0.X ±0.5	COPY		www.fciconnect.com	
A				angles	0.XX ±0.25	projection	title		
				dr	0.XXX ±0.1	MM		7P + 24S	
				engr	0° ±2°	scale		VERTICAL SOLDER RECEPT	
				chr		1:1		product family	PwrBlade
				appd				size	code
sheet index	revision sheet							dwg no	213
								51752-025	sheet 3 of 4

cage code 22526

Tous droits strictement réservés. Reproduction ou communication o des liens interdite sous quelque forme que ce soit sans autorisation écrite du propriétaire. Propriete de c FCI. Droits de reproduction FCI.



All rights strictly reserved. Reproduction or issue to third parties in any form whatever is not permitted without written authority from the proprietor. Property of FCI. Copyright FCI.

PRODUCT NUMBER  
51752-025..  
NOTE: 3

NOTES:

1. DIMENSIONS AND TOLERANCES ARE IN ACCORDANCE WITH ASME Y14.5M, 1994 UNLESS OTHERWISE SPECIFIED.

CONNECTOR NOTES:

- 2 HOUSING MATERIAL: UL 94 V-0 GLASS FILLED HIGH-TEMP THERMOPLASTIC  
POWER CONTACT MATERIAL: COPPER ALLOY  
SIGNAL PIN MATERIAL: COPPER ALLOY
- 3. PLATING SPEC.  
51752-025, 51752-025LF PLATING SPEC. WAS SHOWN IN THE PRINT OF 10064183.
- 4 MANUFACTURER'S NAME, P/N, AND DATE CODE TO APPEAR ON THIS SURFACE.
- 5. PRODUCT SPECIFICATION GS-12-149.  
APPLICATION SPECIFICATION BUS-20-067.
- 6. PACKAGED IN TRAYS.

PCB NOTES:

- 7. ALL HOLE DIAMETERS ARE FINISHED HOLE SIZE.
- 8 MOUNTING HOLES, WHERE APPLICABLE, ARE UNPLATED.
- 9  $\varnothing 1.151 \pm 0.025$  DRILLED HOLES PLATED WITH 0.008 MIN SnPb OR Sn OVER 0.03 TO 0.08 Cu PLATING TO ACHIEVE  $\varnothing 1.02 \pm 0.07$  HOLE.
- 10 "DIM XXX" TO BE DETERMINED BY THE CUSTOMER.
- 11 CONNECTOR KEEP-OUT ZONE.

12. THE VOID CORING IN BETWEEN POWER MODULES, SIGNAL MODULES AND END MODULES ARE OPTIONAL AND THE SHAPE MAY BE DIFFERENT FOR OPTIMIZE THE MOLDING PROCESS. THE VOID CORING WILL NOT EFFECT TO PRODUCT FUNCTION.

mat'l code				tolerances unless otherwise specified		CUSTOMER		FCI		www.fciconnect.com	
lfr	ecn no.	dr	date	linear	0.X ± 0.5	COPY		projection		title	
A					0.XX ± 0.25					7P + 24S VERTICAL SOLDER RECEPT	
				angles	0.XXX ± 0.1					product family PwrBlade code	
				dr	0° ± 2°			size		213	
				engr	Jerome Chen 04/17/08	scale		A		sheet	
				chr	Jerome Chen 04/17/08	1:1		51752-025		4 of 4	
				appd	Gary Hsieh 04/17/08						
					Joseph Hsia 04/17/08						
sheet index	revision sheet										

Pro/E

cage code 22526

PDM: Rev:A

STATUS: Released

Printed: Dec 20, 2010



Компания «ЭлектроПласт» предлагает заключение долгосрочных отношений при поставках импортных электронных компонентов на взаимовыгодных условиях!

Наши преимущества:

- Оперативные поставки широкого спектра электронных компонентов отечественного и импортного производства напрямую от производителей и с крупнейших мировых складов;
- Поставка более 17-ти миллионов наименований электронных компонентов;
- Поставка сложных, дефицитных, либо снятых с производства позиций;
- Оперативные сроки поставки под заказ (от 5 рабочих дней);
- Экспресс доставка в любую точку России;
- Техническая поддержка проекта, помощь в подборе аналогов, поставка прототипов;
- Система менеджмента качества сертифицирована по Международному стандарту ISO 9001;
- Лицензия ФСБ на осуществление работ с использованием сведений, составляющих государственную тайну;
- Поставка специализированных компонентов (Xilinx, Altera, Analog Devices, Intersil, Interpoint, Microsemi, Aeroflex, Peregrine, Syfer, Eurofarad, Texas Instrument, Miteq, Cobham, E2V, MA-COM, Hittite, Mini-Circuits, General Dynamics и др.);

Помимо этого, одним из направлений компании «ЭлектроПласт» является направление «Источники питания». Мы предлагаем Вам помощь Конструкторского отдела:

- Подбор оптимального решения, техническое обоснование при выборе компонента;
- Подбор аналогов;
- Консультации по применению компонента;
- Поставка образцов и прототипов;
- Техническая поддержка проекта;
- Защита от снятия компонента с производства.



#### Как с нами связаться

**Телефон:** 8 (812) 309 58 32 (многоканальный)

**Факс:** 8 (812) 320-02-42

**Электронная почта:** [org@eplast1.ru](mailto:org@eplast1.ru)

**Адрес:** 198099, г. Санкт-Петербург, ул. Калинина, дом 2, корпус 4, литера А.