

Materials			
No.	Component name	Base material	Finish
1	Housing	High Temp., UL 94V-0, green	
2	End terminal	silver clad copper alloy	5 microinches min. gold
3	Center terminal	copper alloy	5 microinches min. gold
4	Rocker contact	silver clad copper alloy	5 microinches min. gold
5	Actuator	Phenol resin, UL94 HB, black	
6	Plunger	stainless steel	
7	Spring	music wire	
8	Toggle	brass	chrome or Nickel
9	Retainer	Polyamide, UL94 HB, black	
10	Frame	cold rolled steel	zinc or Nickel
11	Bushing	brass	100 microinches min. nickel over 10 microinches min. copper
12	Mounting nuts (2)	brass	200 microinches min. bright nickel
13	Locating ring	cold rolled steel	zinc or Nickel
14	Internal tooth lockwasher	steel	zinc or Nickel

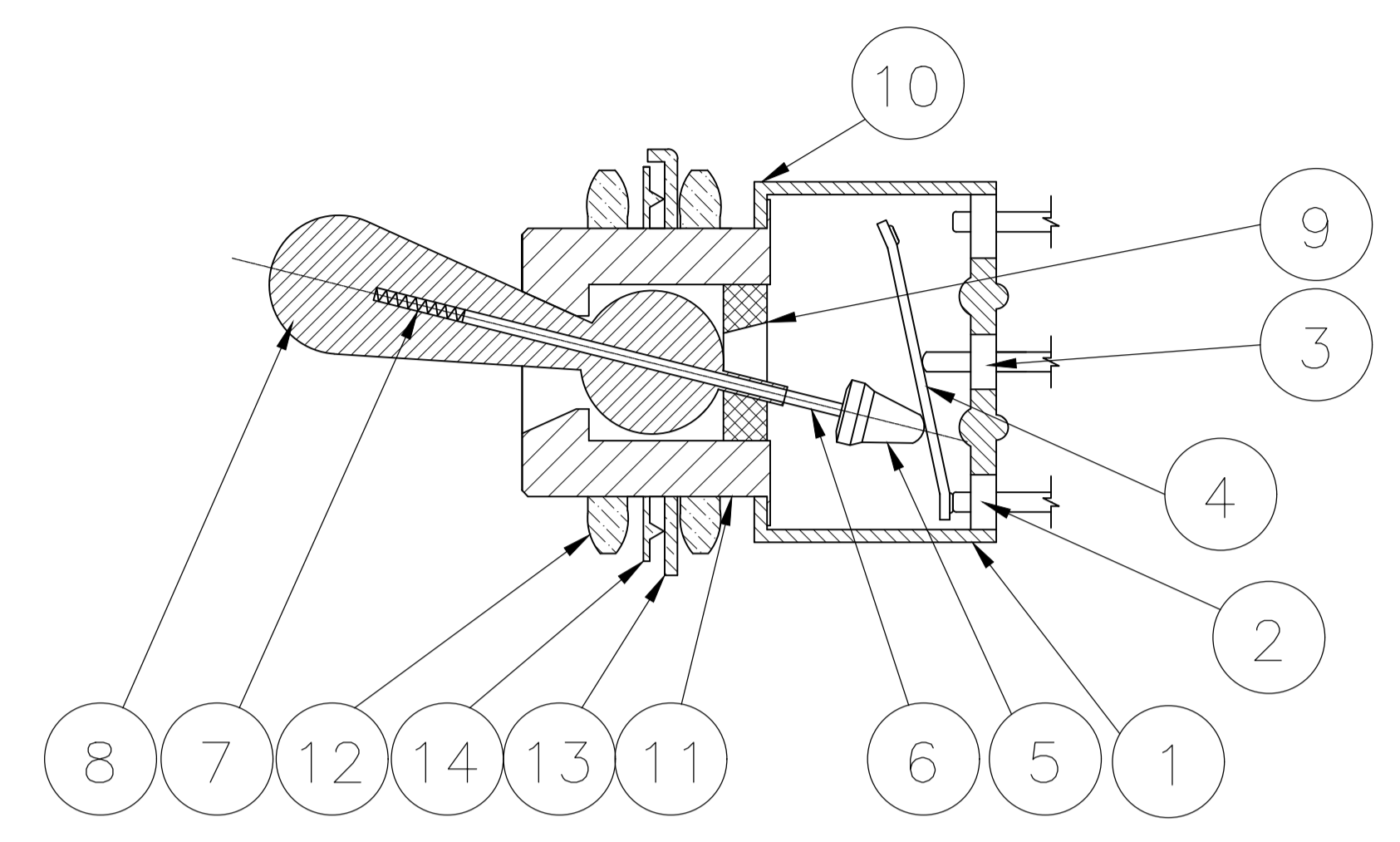

NOT TO SCALE

Specifications—see note 3				
Current rating UL & CSA	6A @ 125 VAC (resistive)			
	3A @ 250 VAC (resistive)			
	4A @ 28 VDC (resistive)			
Termination resistance	20 milliohms max @ 2-4 VDC, 1A			
Insulation resistance	1,000 megohms min.			
Withstanding voltage	1,000 VAC			
Travel	24 +/-6 degrees			
Actuation force	.05 to 1.5 kgf			
Operating temperature	-20C to +85C			
Storage temperature	-40C to +85C			
Contact timing	break before make			
Terminal seal	epoxy or insert molded			
Durability	Parameter	2 Position	3 Position	Momentary
	mechanical (no load)	150,000	100,000	80,000
	250 VAC (3A resistive)	80,000	60,000	60,000
	125 VAC (6A resistive)	80,000	60,000	60,000
	28 VDC (4A resistive)	60,000	50,000	40,000

Part Number	Alco Model	Poles	Throws	Function	Terminal	A	Diagram 1	Diagram 2	Diagram 3	Comments
3-1437559-2	MTG406P	4	2	ON OFF ON	Wire lug	.453	2-3, 5-6, 8-9, 11-12	Off	2-1, 5-4, 8-7, 11-10	
3-1437559-3	MTG426N	4	2	ON ON	Wire lug	.685	2-3, 5-6, 8-9, 11-12	---	2-1, 5-4, 8-7, 11-10	
3-1437559-1	MTG406N	4	2	ON ON	Wire lug	.453	2-3, 5-6, 8-9, 11-12	---	2-1, 5-4, 8-7, 11-10	
2-1437559-9	MTG306E	3	2	ON OFF ON	Wire lug	.453	2-3, 5-6, 8-9	Off	2-1, 5-4, 8-7	
3-1437559-0	MTG326D	3	2	ON ON	Wire lug	.685	2-3, 5-6, 8-9	---	2-1, 5-4, 8-7	
2-1437559-8	MTG306D	3	2	ON ON	Wire lug	.453	2-3, 5-6, 8-9	---	2-1, 5-4, 8-7	
2-1437559-7	MTG226PA	1	3	ON ON ON	Wire lug	.685	5-6	5-3	5-1	note 6
2-1437559-6	MTG226P	2	2	ON OFF ON	Wire lug	.685	2-3, 5-6	Off	2-1, 5-4	
2-1437559-5	MTG226N	2	2	ON ON	Wire lug	.685	2-3, 5-6	---	2-1, 5-4	
2-1437559-4	MTG206T	2	2	ON OFF(ON)	Wire lug	.453	2-3, 5-6	Off	2-1, 5-4	
2-1437559-3	MTG206S	2	2	(ON) OFF (ON)	Wire lug	.453	2-3, 5-6	Off	2-1, 5-4	
2-1437559-2	MTG206R	2	2	ON (ON)	Wire lug	.453	2-3, 5-6	---	2-1, 5-4	
2-1437559-1	MTG206PA	1	3	ON ON ON	Wire lug	.453	5-6	5-3	5-1	note 6
2-1437559-0	MTG206P	2	2	ON OFF ON	Wire lug	.453	2-3, 5-6	Off	2-1, 5-4	
1-1437559-9	MTG206NPC	2	2	ON ON	PC	.453	2-3, 5-6	---	2-1, 5-4	
1-1437559-8	MTG206N	2	2	ON ON	Wire lug	.453	2-3, 5-6	---	2-1, 5-4	
1-1437559-0	MTG126G	1	2	(ON) OFF (ON)	Wire lug	.685	2-3	Off	2-1	
1-1437559-7	MTG126E	1	2	ON OFF ON	Wire lug	.685	2-3	Off	2-1	
1-1437559-6	MTG126D	1	2	ON ON	Wire lug	.685	2-3	---	2-1	
1-1437559-5	MTG106H	1	2	ON OFF(ON)	Wire lug	.453	2-3	Off	2-1	
1-1437559-4	MTG106G	1	2	(ON) OFF (ON)	Wire lug	.453	2-3	Off	2-1	
1-1437559-3	MTG106F	1	2	ON (ON)	Wire lug	.453	2-3	---	2-1	
1-1437559-2	MTG106E	1	2	ON OFF ON	Wire lug	.453	2-3	Off	2-1	
1-1437559-1	MTG106D	1	2	ON ON	Wire lug	.453	2-3	---	2-1	

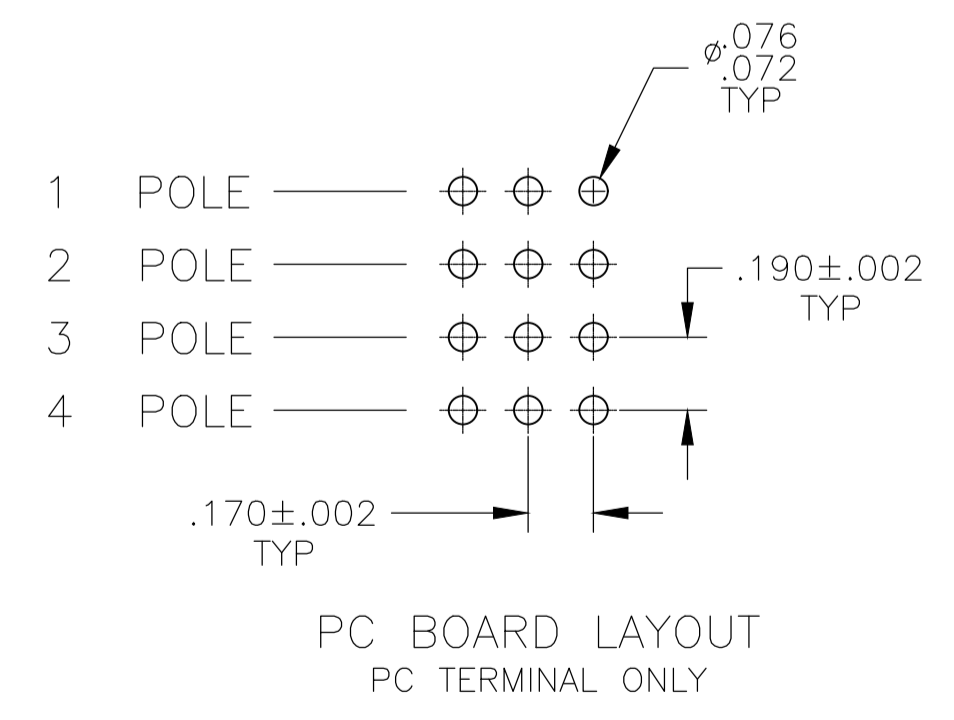
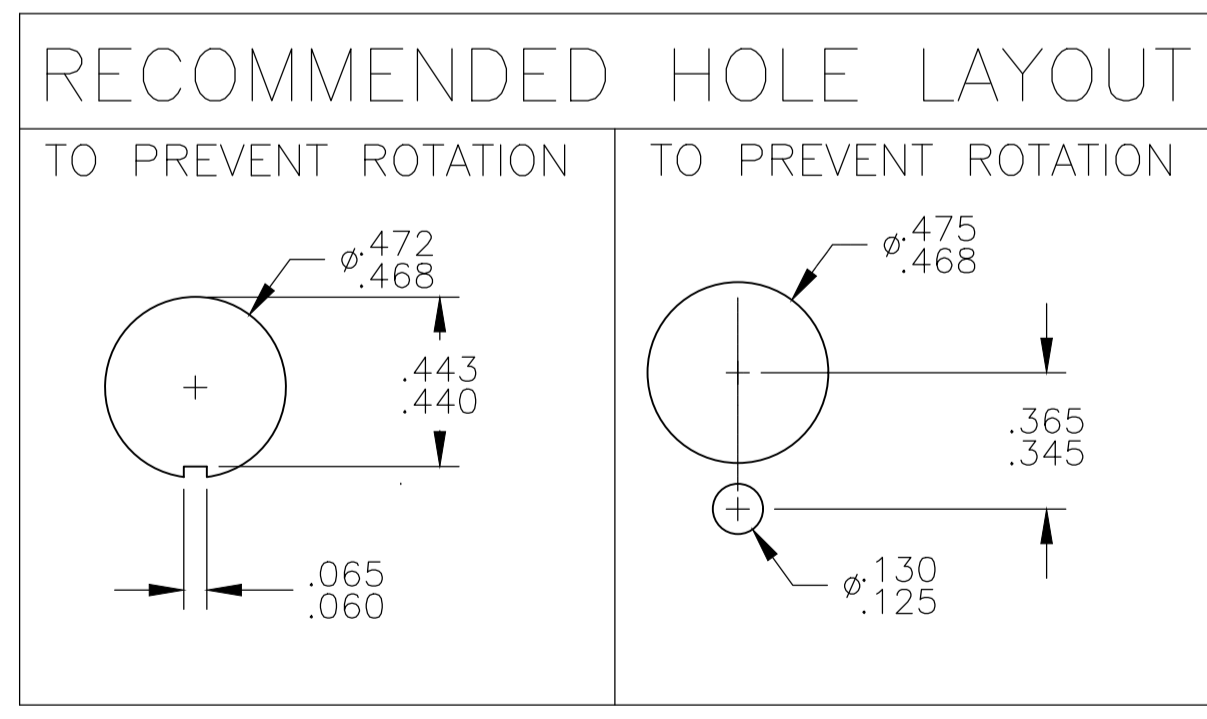

- NOTES:
- TERMINAL NUMBERS ARE FOR REFERENCE ONLY AND DO NOT APPEAR ON THE SWITCHES.
 - EACH SWITCH SUPPLIED WITH THE FOLLOWING MOUNTING HARDWARE:
 - (2) 15/32-32 UNS-2B HEX NUTS
 - (1) INTERNAL TOOTH LOCKWASHER
 - (1) LOCATING RING
 - WIRE LUG CONTACTS WILL ACCEPT 2 #20 AWG SOLID OR STRANDED WIRES.
 - CUSTOMER INSTALLED EXTERNAL JUMPER BETWEEN TERMINALS 2 AND 4 REQUIRED FOR 1 POLE 3 THROW FUNCTION.
 - OBSOLETE
 - LASER MARKING USED FOR PARTS.

THIS DRAWING IS A CONTROLLED DOCUMENT.

DIN M. BINNER 29DEC03
 CHK: M. ZITTO 29DEC03
 APPV: M. ZITTO 29DEC03

TE Connectivity Ltd.

TOGGLE SWITCH, MTG SERIES
 VERTICAL MOUNT

SIZE: A1 CASE CODE: 00779 DRAWING NO: 1-1437559-1
 WEIGHT: CUSTOMER DRAWING SCALE: 2:1 SHEET: 1 OF 3 REV: D6

REVISIONS				
P	LYR	DESCRIPTION	DATE	OWN
-	-	SEE SHEET 1	-	-

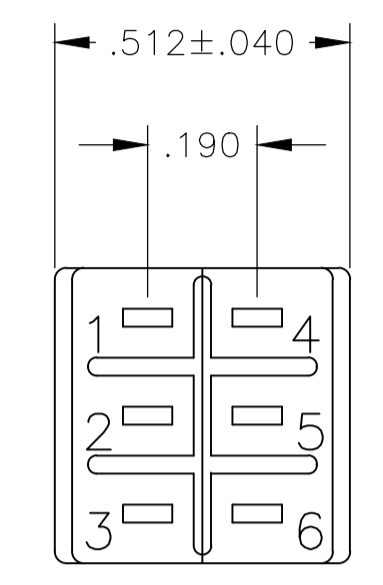
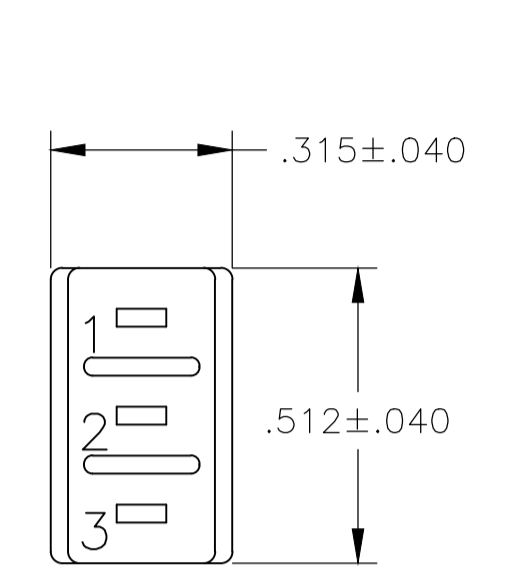
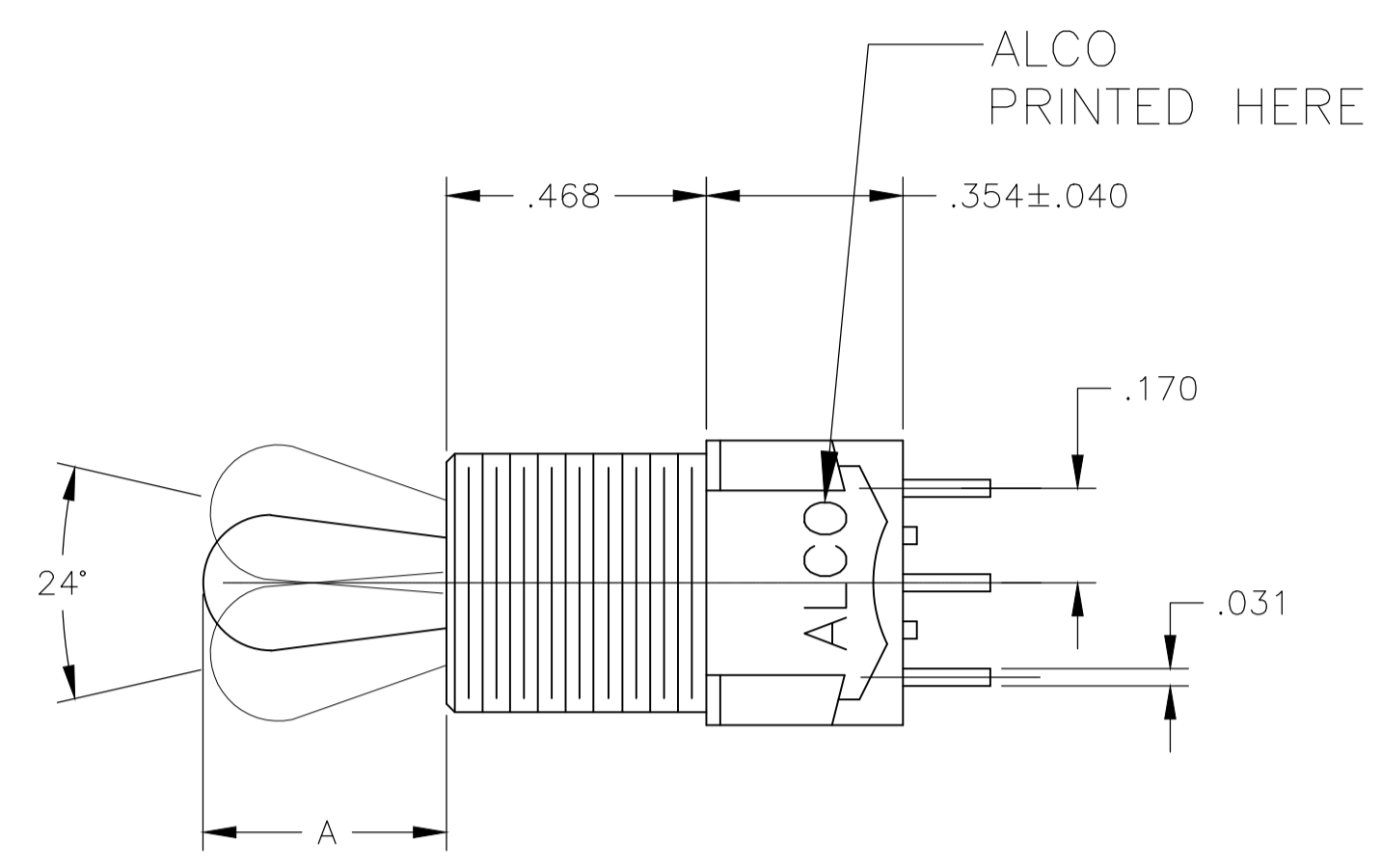

MTG-106

MTG-206

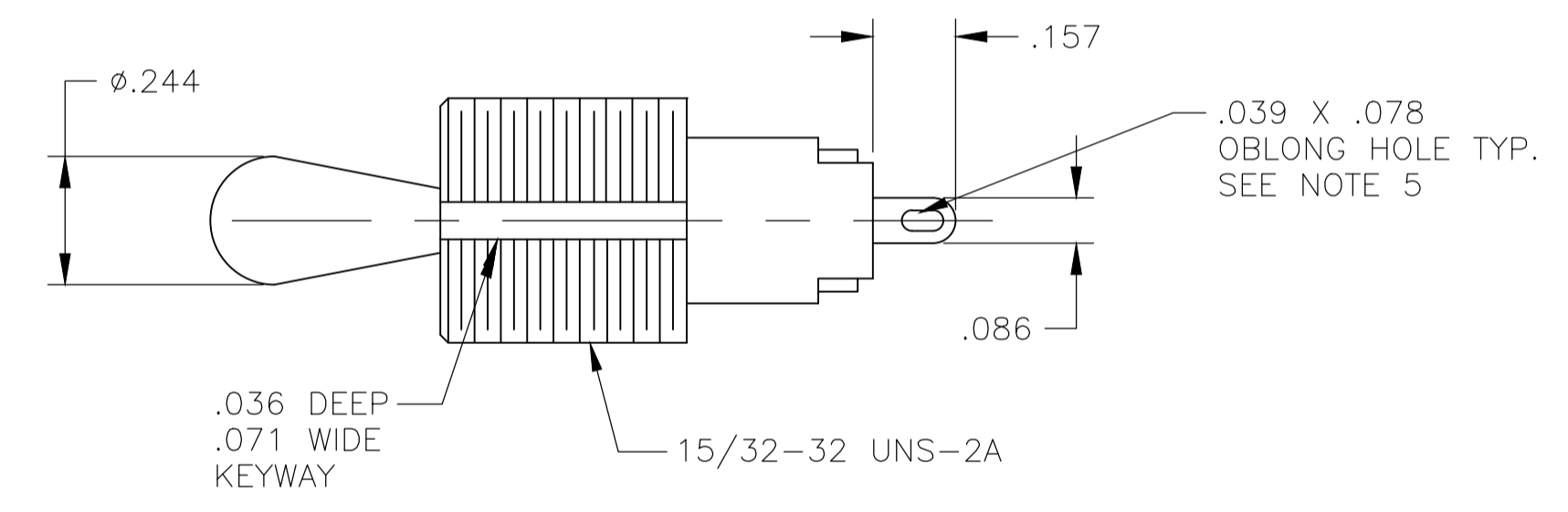
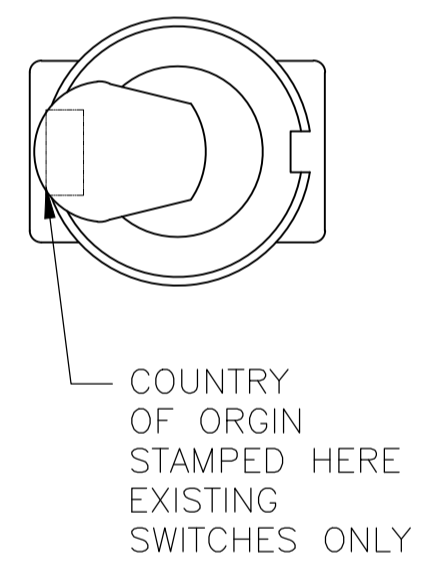

WIRE LUG TERMINAL

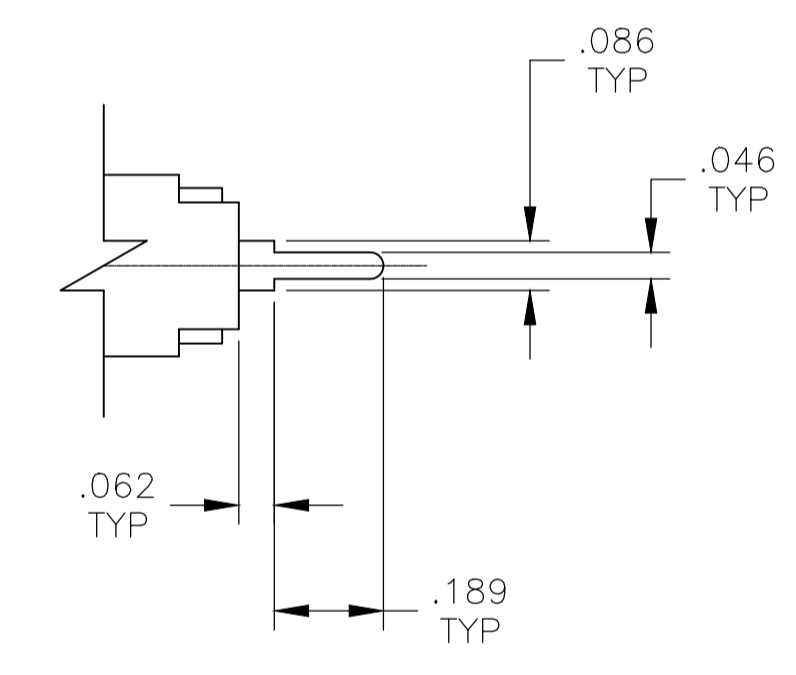

PC TERMINAL

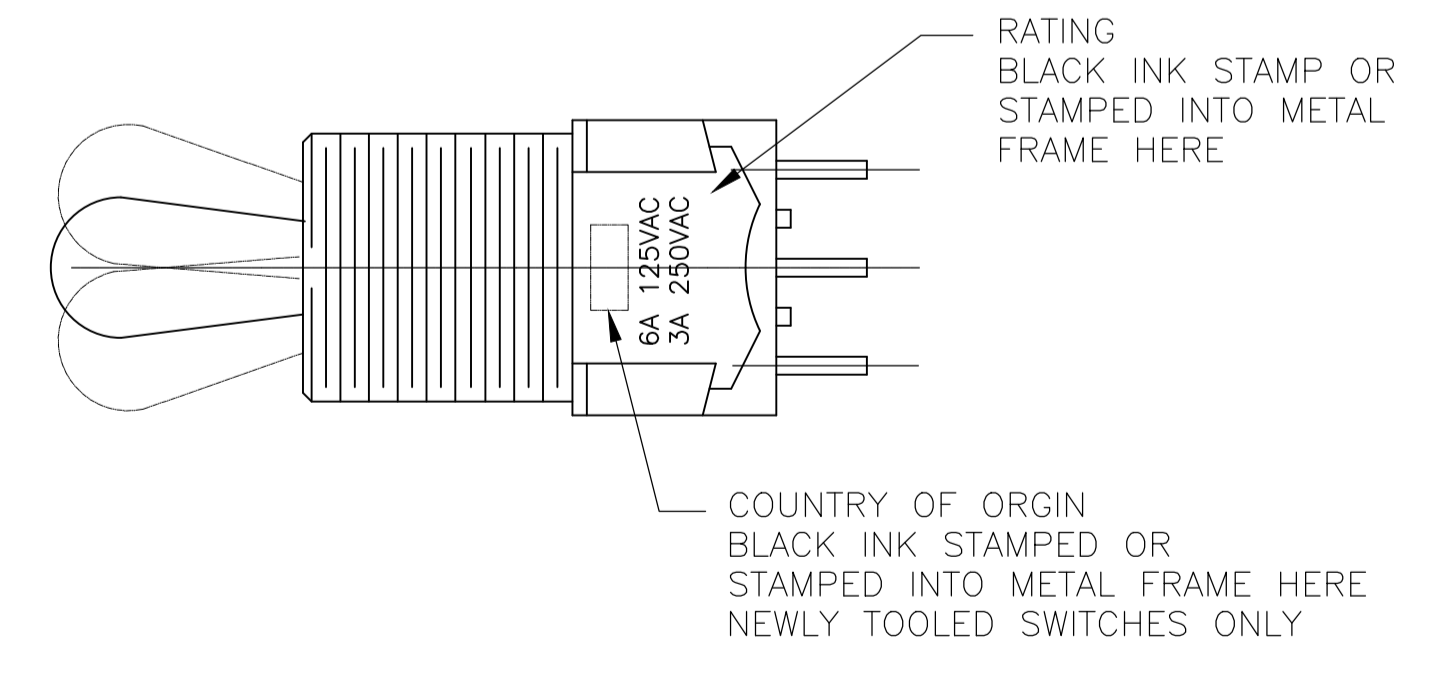

THIS DRAWING IS A CONTROLLED DOCUMENT.		DWG: M. BINNER 29DEC03	TE Connectivity Ltd.
DIMENSIONS: INCHES		CHK: M. ZITTO 29DEC03	
TOLERANCES UNLESS OTHERWISE SPECIFIED:		APP'D: M. ZITTO 29DEC03	NAME: TOGGLE SWITCH, MTG SERIES VERTICAL MOUNT
0. PLC ± -	1. PLC ± -	PRODUCT SPEC	APPLICATION SPEC
2. PLC ± -	3. PLC ± .005	SIZE	CAGE CODE
4. PLC ± -	ANGLES ± -	WEIGHT	DRAWING NO.
MATERIAL	FINISH	RESTRICTED TO	SCALE 3:1
CUSTOMER DRAWING		SIZE A1	REV D6
		DWG NO. 00779	SHEET 2 OF 3
		DRAWING NO. 1-1437559-1	REV D6

REVISIONS				
P	LTR	DESCRIPTION	DATE	OWN
-	-	SEE SHEET 1	-	-

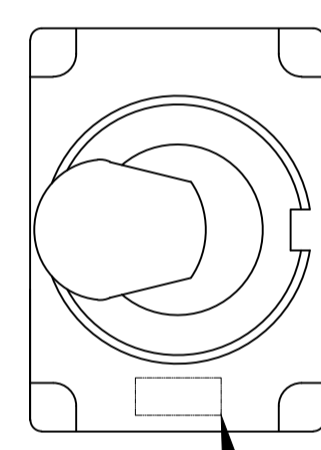
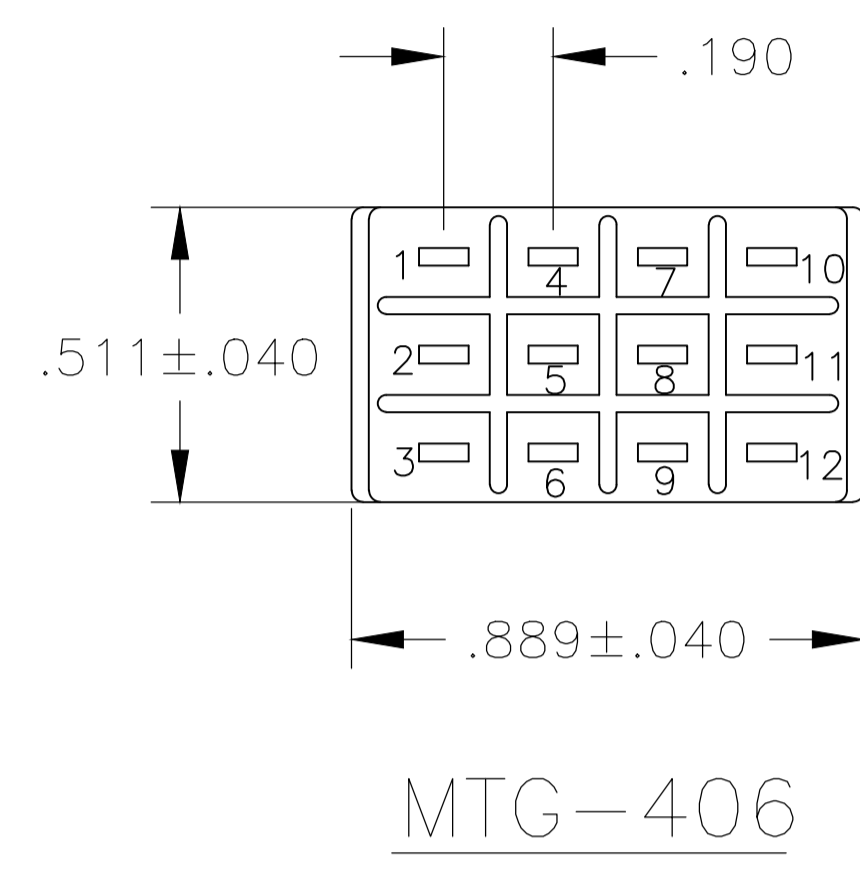
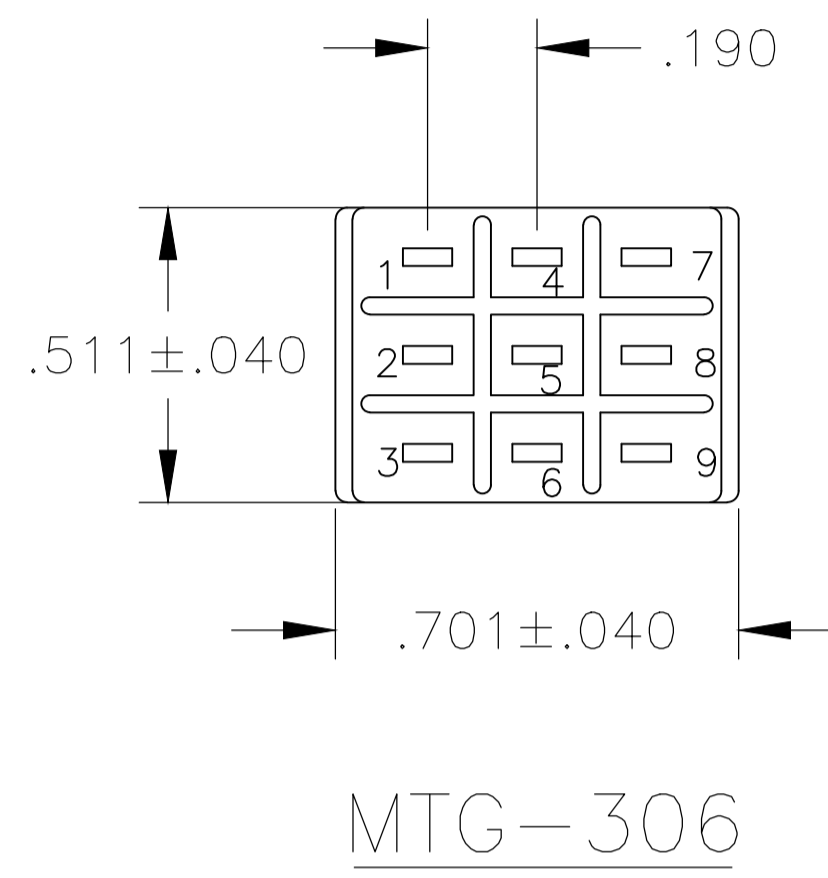
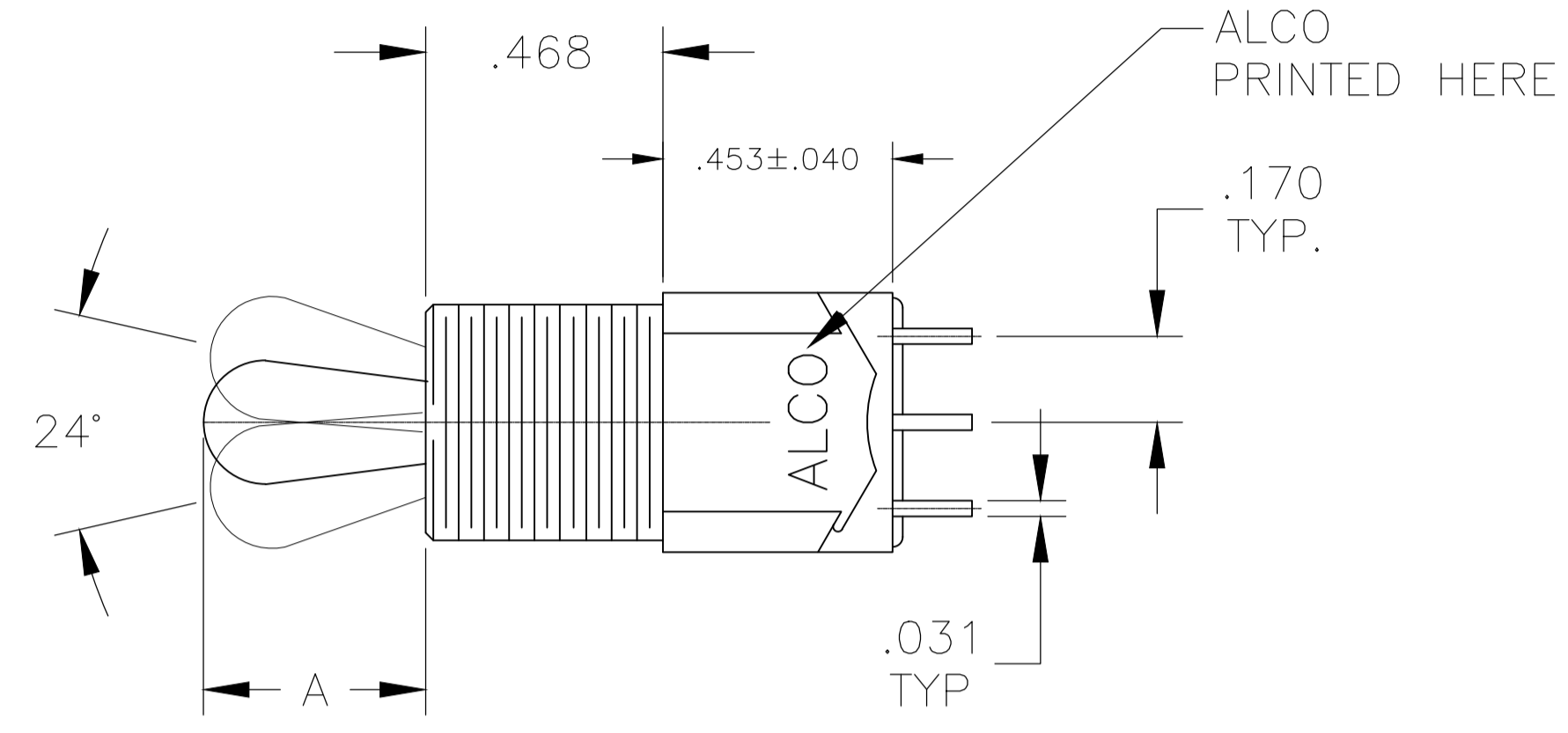

COUNTRY OF ORIGIN STAMPED HERE EXISTING SWITCHES ONLY

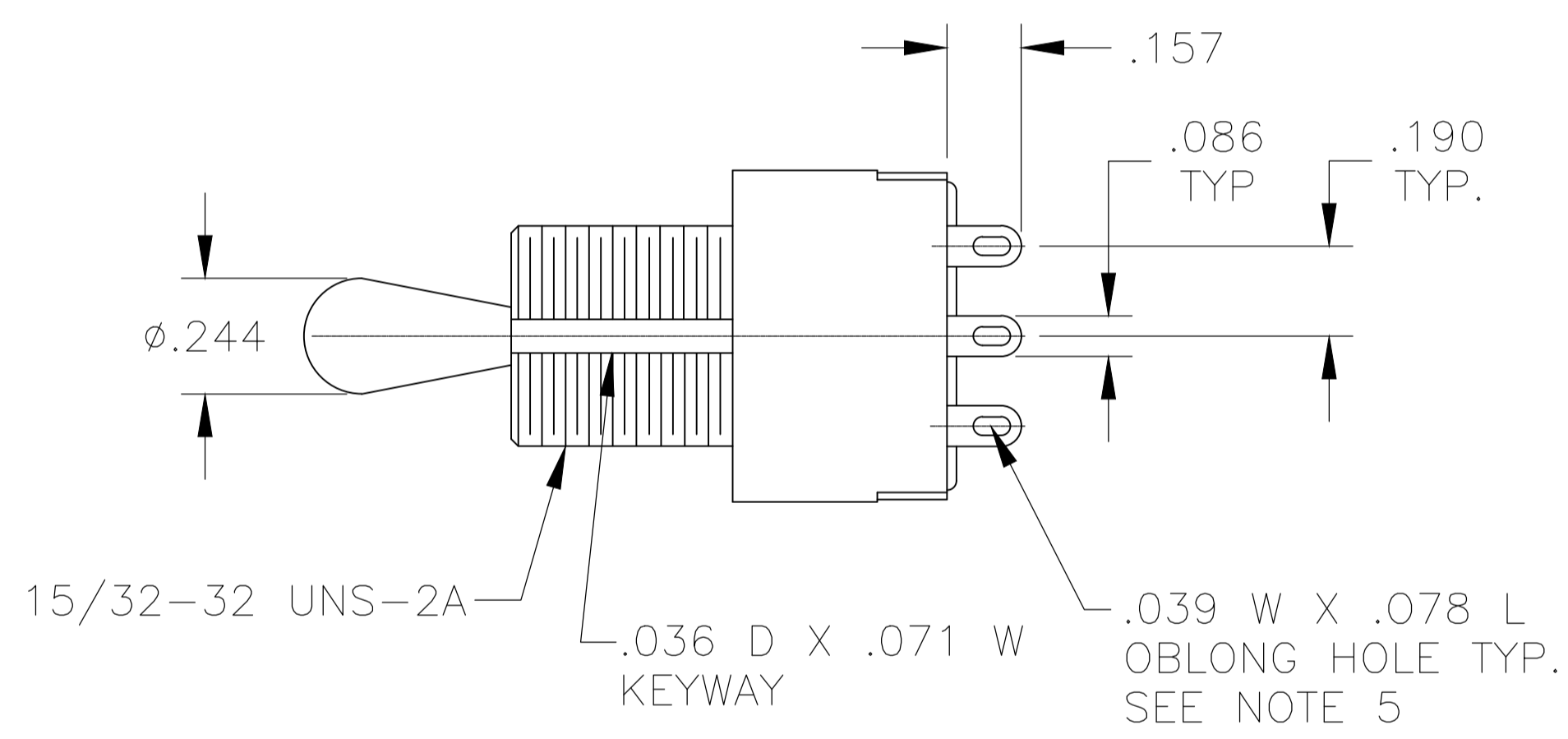

WIRE LUG TERMINAL

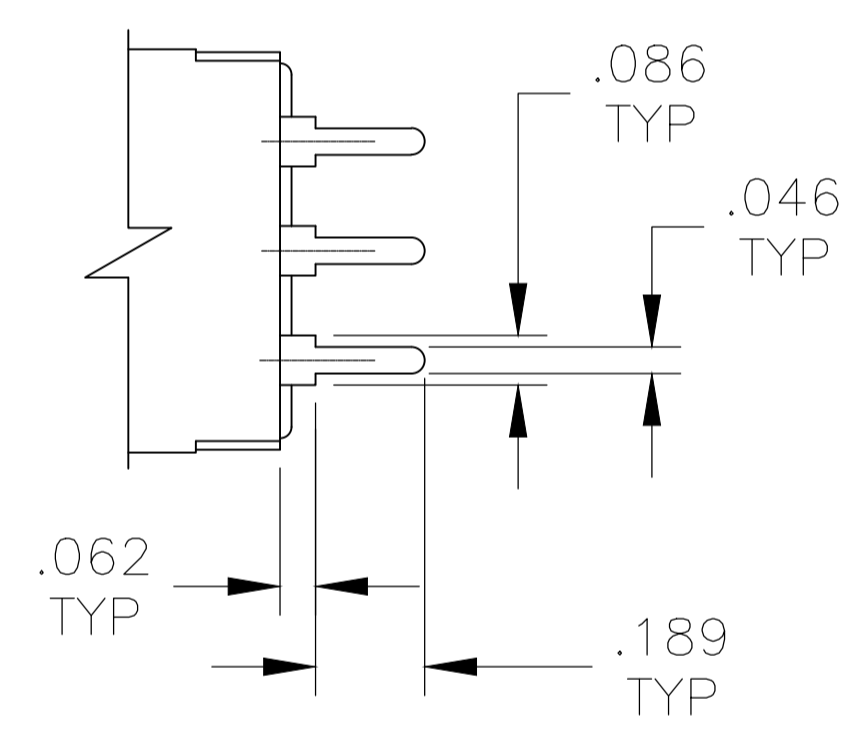

PC TERMINAL

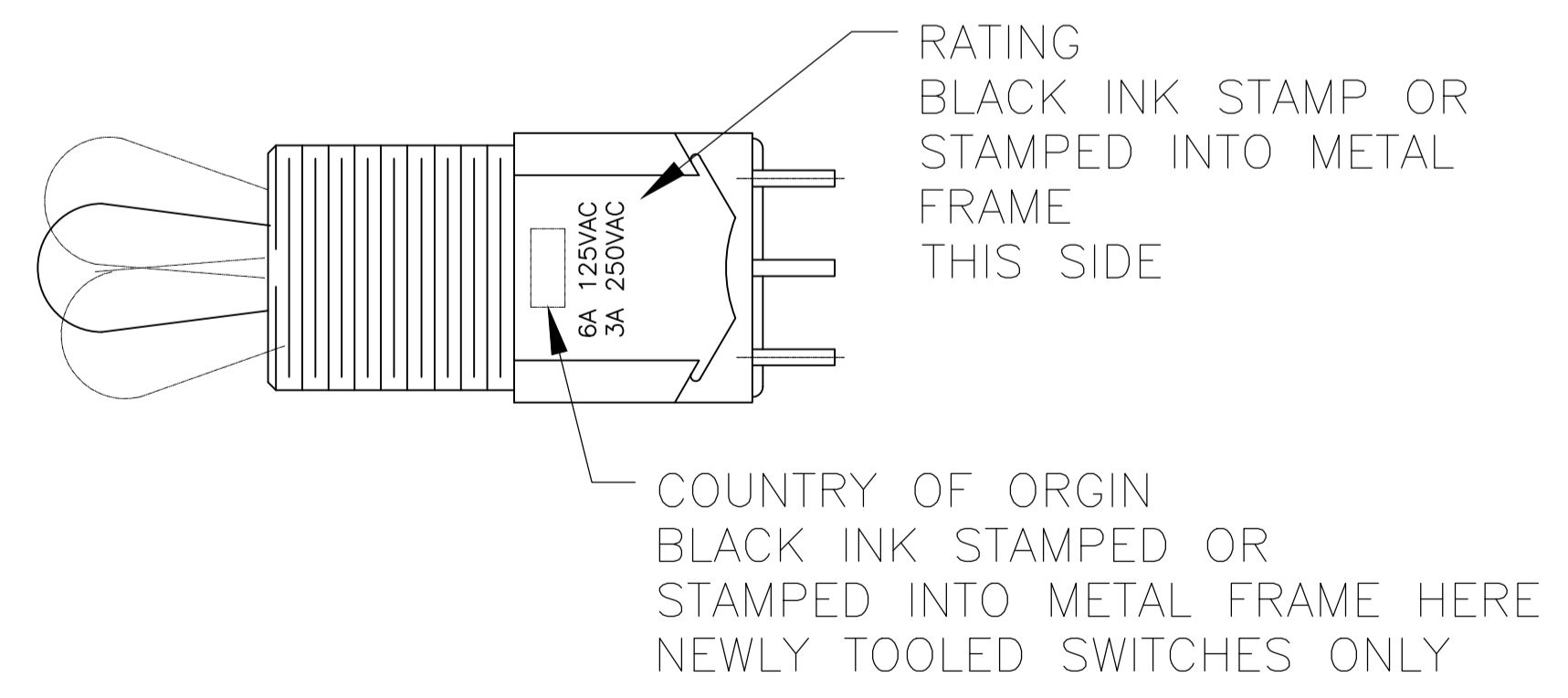

THIS DRAWING IS A CONTROLLED DOCUMENT.		DWG: M. BINNER 29DEC03	TE Connectivity Ltd.
DIMENSIONS: INCHES		CHK: M. ZITTO 29DEC03	
TOLERANCES UNLESS OTHERWISE SPECIFIED:		APP'D: M. ZITTO 29DEC03	NAME: TOGGLE SWITCH, MTG SERIES VERTICAL MOUNT
0. PLC ± -	1. PLC ± -	PRODUCT SPEC	APPLICATION SPEC
2. PLC ± -	3. PLC ± .005	SIZE: A1	CAGE CODE: 00779
4. PLC ± -	ANGLES ± -	DRAWING NO: 1-1437559-1	RESTRICTED TO: -
MATERIAL: -	FINISH: -	WEIGHT: -	CUSTOMER DRAWING
		SCALE: 3:1	SHEET 3 OF 3 REV D6



Компания «ЭлектроПласт» предлагает заключение долгосрочных отношений при поставках импортных электронных компонентов на взаимовыгодных условиях!

Наши преимущества:

- Оперативные поставки широкого спектра электронных компонентов отечественного и импортного производства напрямую от производителей и с крупнейших мировых складов;
- Поставка более 17-ти миллионов наименований электронных компонентов;
- Поставка сложных, дефицитных, либо снятых с производства позиций;
- Оперативные сроки поставки под заказ (от 5 рабочих дней);
- Экспресс доставка в любую точку России;
- Техническая поддержка проекта, помощь в подборе аналогов, поставка прототипов;
- Система менеджмента качества сертифицирована по Международному стандарту ISO 9001;
- Лицензия ФСБ на осуществление работ с использованием сведений, составляющих государственную тайну;
- Поставка специализированных компонентов (Xilinx, Altera, Analog Devices, Intersil, Interpoint, Microsemi, Aeroflex, Peregrine, Syfer, Eurofarad, Texas Instrument, Miteq, Cobham, E2V, MA-COM, Hittite, Mini-Circuits, General Dynamics и др.);

Помимо этого, одним из направлений компании «ЭлектроПласт» является направление «Источники питания». Мы предлагаем Вам помощь Конструкторского отдела:

- Подбор оптимального решения, техническое обоснование при выборе компонента;
- Подбор аналогов;
- Консультации по применению компонента;
- Поставка образцов и прототипов;
- Техническая поддержка проекта;
- Защита от снятия компонента с производства.



Как с нами связаться

Телефон: 8 (812) 309 58 32 (многоканальный)

Факс: 8 (812) 320-02-42

Электронная почта: org@eplast1.ru

Адрес: 198099, г. Санкт-Петербург, ул. Калинина, дом 2, корпус 4, литера А.