

FB-6SP and FB-12SP

Block device couplers

Data sheet
3177_en_A

© PHOENIX CONTACT 2015-01-20



1 Description

The FB-6SP and FB-12SP block couplers provide an interface between the fieldbus trunk cable and field devices on Foundation Fieldbus™ and PROFIBUS PA bus systems. Limited width on the rail reduces the required footprint and weight of the field enclosure.

The FB...SP couplers connect to the trunk utilizing a T-connector terminal block with preinstalled terminator, ensuring termination is always available and error free.

The block couplers feature short-circuit protection to the trunk. The single-sided plug configuration makes wiring in a field enclosure easy. Diagnostic LEDs include DC OK and spur fault on the segment.

2 Features

- Small footprint for efficient enclosure space usage.
- Provide Ex nA [nL], Ex nA [ic] or FISCO ic spur connections



Make sure you always use the latest documentation.
It can be downloaded at phoenixcontact.com.



This data sheet is valid for all products listed on the following page:

3 Ordering data

Products

Description	Type	Order No.	Pcs./Pkt.
Device coupler, 6-spur, includes T-bus connector	FB-6SP	2316307	1
Device coupler, 12-spur, includes T-bus connector	FB-12SP	2316310	1

Accessories

Description	Type	Order No.	Pcs./Pkt.
Field diagnostics module, legacy installations	FB-DIAG/FF/LI	2316284	1
Connector, reverse, for field diagnostics module	MVSTBW 2,5/ 3-STF-5,082CPBD:NZ	1707058	1
Power supply plug, 500 mA, 28 V DC	FB-PS-PLUG-24DC/28DC/0.5/EX	2316132	1
Power supply base	FB-PS-BASE/EX	2316145	1
Surge protective plug, for floating signal circuit	PT 2X2-FF-ST	2800755	10
Base element, for four signal lines with floating ground	PT 4+F-BE	2839415	10
Enclosure, 15 ports, aluminum	FB-15-AL	2316187	1
Enclosure, 15 ports, stainless steel	FB-15-SS	2316190	1
Enclosure, 8 ports, aluminum	FB-8-AL	2316200	1
Enclosure, 9 ports, stainless steel	FB-9-SS	2316213	1

4 Technical data

General data

Number of spurs	
FB-6SP	6
FB-12SP	12
Number of spurs per segment	24
Ambient temperature (operating)	-50°C ... 70°C
Temperature (storage)	-50°C ... 85°C
Relative humidity, non-condensing	<95%
Degree of protection	IP20
Flammability rating, UL94	V0
Mounting	NS35 (EN 60715)
Weight	
FB-6SP	240 g
FB-12SP	395 g

Connections

Type	Removable spur and trunk connectors, screw clamp
Conductor cross-section	0.5 ... 2.5 mm ² (24 ... 12 AWG)

Electrical data

Current draw, maximum per spur	35 mA
Short circuit current, per spur	56 mA
Supply voltage, minimum	
FB-6SP	10.5 V DC
FB-12SP	10.6 V DC
Maximum supply voltage	32.0 V DC
Rated voltage per spur	≤32.0 V
Voltage drop	
Trunk in to trunk out	≤0.1 V
Trunk in to spur out	≤1.25 V
Termination, external removable plug	100 Ω
Trunk voltage protection	Active if voltage exceeds 34.5 V
Current consumption at no load	
FB-6SP with terminator	8.8 mA
FB-6SP without terminator	4.8 mA
FB-12SP with terminator	10.5 mA
FB-12SP without terminator	6.5 mA
Maximum power dissipation at maximum load and voltage	
FB-6SP with terminator	0.29 W
FB-12SP with terminator	0.34 W

Hazardous location ratings

Temperature, T _a	-50°C ... 90°C
Voltage, U _o	U _i
Current, I _o	56 mA
Capacitance, C _i	0 μA
Inductance, L _i	4 μF
Capacitance, C _o	80 nF
Inductance, L _o	0.26 mH

Conformance

Shock resistance	30g, 11 ms
Vibration resistance	5g, 10-150 Hz
Foundation Fieldbus	FF-846
IEC	60529, 61158-2
NE	NE21
EN	EN 61326, EN 60068-2-27, EN 60068-2-6

Approvals

ATEX	Sira 13ATEX4247X; II 3(3)G Ex nA [ic] IIC T4 Gc, Entity/FISCO ic spurs Ex nA [nL] IIC T4 Gc; II 3G Ex ic IIC T4 Gc, FISCO ic
IECEX	IECEX SIR 13.0089X; Ex nA [ic] IIC T4 Gc, Entity/FISCO ic spurs; Ex nA [nL] IIC T4 Gc; Ex ic IIC T4 Gc, FISCO ic
CSA	Class I, Div. 2, Groups A, B, C, D Ex nA [nL] IIC T4; Class I, Zone 2, AEx nA [nC] IIC T4

5 Dimensions

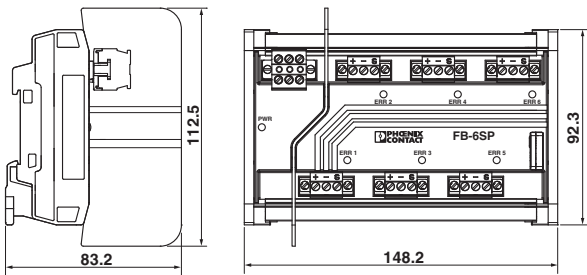

Figure 1 FB-6SP

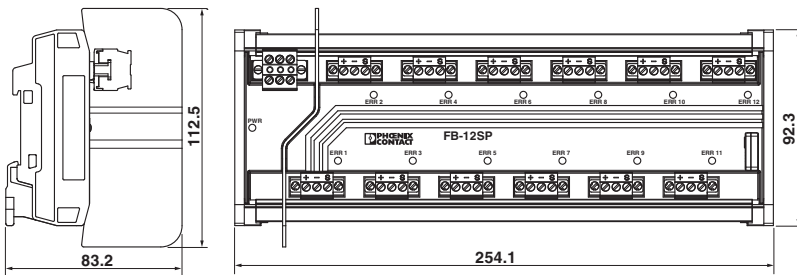

Figure 2 FB-12SP

6 Schematics

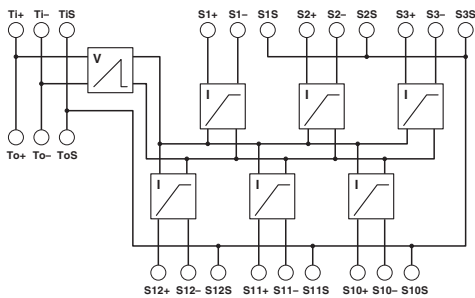

Figure 3 FB-6SP circuit diagram

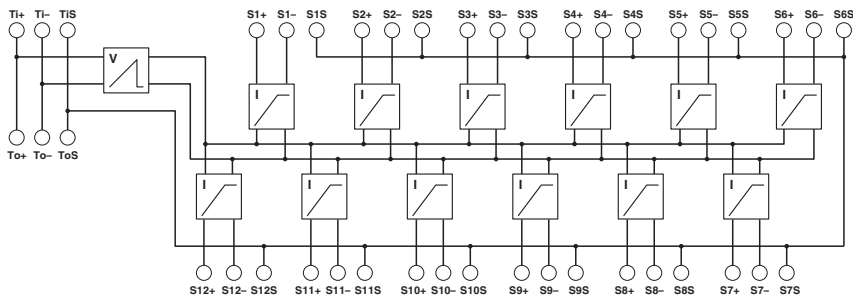

Figure 4 FB-12SP circuit diagram

7 Installation

7.1 Mounting

The block coupler installs on NS35 (EN 50022) mounting rail.

1. Secure the rail to an appropriate surface.
2. Place the block coupler onto the DIN rail from above. The upper holding keyway must be hooked onto the edge of the DIN rail.
3. Push the block coupler from the front toward the mounting surface, making sure both sides of the coupler snap onto the rail.

7.2 Connections

Foundation Fieldbus and PROFIBUS PA network configurations are bus-type networks. Each device coupler includes removable connectors.



Only one device can be connected to each spur.

Table 1 shows the trunk and spur connections.

Connection	Label	Function
Trunk	TiS	Trunk in shield
	Ti-	Trunk in -
	Ti+	Trunk in +
	ToS	Trunk out shield
	To-	Trunk out -
	To+	Trunk out +
Spur	SnS	Spur <i>n</i> shield
	Sn-	Spur <i>n</i> -
	Sn+	Spur <i>n</i> +

where *n* indicates the spur number. Couplers may have multiple spur connectors.

8 Operation

8.1 LEDs

Each spur has a dedicated LED.

Label	Indicator	Meaning
PWR	Solid green	Power is present
	Off	No power is applied
ERR	Solid red	Short circuit in spur <i>n</i>
	Off	Normal operation



Компания «ЭлектроПласт» предлагает заключение долгосрочных отношений при поставках импортных электронных компонентов на взаимовыгодных условиях!

Наши преимущества:

- Оперативные поставки широкого спектра электронных компонентов отечественного и импортного производства напрямую от производителей и с крупнейших мировых складов;
- Поставка более 17-ти миллионов наименований электронных компонентов;
- Поставка сложных, дефицитных, либо снятых с производства позиций;
- Оперативные сроки поставки под заказ (от 5 рабочих дней);
- Экспресс доставка в любую точку России;
- Техническая поддержка проекта, помощь в подборе аналогов, поставка прототипов;
- Система менеджмента качества сертифицирована по Международному стандарту ISO 9001;
- Лицензия ФСБ на осуществление работ с использованием сведений, составляющих государственную тайну;
- Поставка специализированных компонентов (Xilinx, Altera, Analog Devices, Intersil, Interpoint, Microsemi, Aeroflex, Peregrine, Syfer, Eurofarad, Texas Instrument, Miteq, Cobham, E2V, MA-COM, Hittite, Mini-Circuits, General Dynamics и др.);

Помимо этого, одним из направлений компании «ЭлектроПласт» является направление «Источники питания». Мы предлагаем Вам помощь Конструкторского отдела:

- Подбор оптимального решения, техническое обоснование при выборе компонента;
- Подбор аналогов;
- Консультации по применению компонента;
- Поставка образцов и прототипов;
- Техническая поддержка проекта;
- Защита от снятия компонента с производства.



Как с нами связаться

Телефон: 8 (812) 309 58 32 (многоканальный)

Факс: 8 (812) 320-02-42

Электронная почта: org@eplast1.ru

Адрес: 198099, г. Санкт-Петербург, ул. Калинина, дом 2, корпус 4, литера А.