

FXC7000 Series AC-DC Power Supply



Key Features & Benefits

- Three-Phase AC Input
- Suitable for 3U or 5U Height Mounting
- Single-Wire Current Share or Droop Current Share
- Remote Voltage Adjust and Current Monitoring
- Overtemperature, Overload and Overvoltage Protection
- LED Supply Status Indicators
- Current-Share Control for up to 30 Units
- Front Panel Selectable-Input-Range
- RoHS Compliant

The FXC7000 Series of standalone or rack-mounted power systems provides true AC front-end capability to automatic test equipment, telecom, data communications, and other distributed power designs. The FXC systems may be paralleled up to 210 kW of output power and are intended for chassis-mounted installations with bolted connections. These power supplies provide excellent protection against input voltage transients.

The FXC has its fan located at the front of the supply, and voltage adjust, indicator lights, output busbars, and connectors on the rear. Airflow is from the front through the rear. Alarm, monitoring, and control signals are floating from the main output and can be referenced to the positive or negative output or sense line of the power supply. The output is floating with respect to the chassis and may be used as a positive or negative polarity supply.

The FXC7000 Series meets international safety requirements and is CE Marked to the Low Voltage Directive. This series operates on three-phase European voltages as well as (up to) 480 VAC, delta or wye.

North America

+1-866.513.2839

Asia-Pacific

+86.755.29885888

Europe, Middle East

+353 61 225 977

tech.support@psbel.com

belpowersolutions.com

FXC7000 Series

MODEL SELECTION

MODEL	OUTPUT VOLTAGE	INPUT VOLTAGE RANGE 3-PHASE	ADJUSTMENT RANGE	MAXIMUM OUTPUT CURRENT	LINE REGULATION	LOAD REGULATION ¹	INITIAL SETTING ACCURACY
FXC7000-48-SG ^{2,3}	48 V	180 to 264 VAC or 342 to 528 VAC	45.6 V to 50.4 V	145 A	0.15%	0.2%	47.90 V to 48.10 V

INPUT SPECIFICATIONS

All specifications apply over specified input voltage, output load, and temperature range, unless otherwise noted.

PARAMETER	CONDITIONS / DESCRIPTION	MIN	NOM	MAX	UNITS
Input Voltage-AC	3-phase delta low input range, nominal	200		240	VAC
	3-phase delta high input range, nominal	380		480	VAC
	Continuous deviation from the above nominals	-10		+10	%
Input Current	Per phase at full rated load		FXC7000 at 180 VAC		30 Arms
Inrush Surge Current	Internally limited			30	Apk
			$V_{in} = 264 \text{ VAC (one cycle, } 25^{\circ}\text{C)}$	15	Apk
Input Frequency	AC input	47		63	Hz
Hold-up Time	After last AC line peak at full power	208 VAC	17		ms
		400 VAC	13		ms
Operating Frequency	Switching frequency, fixed		100		kHz
Power Factor		0.9			W/VA

OUTPUT SPECIFICATIONS

PARAMETER	CONDITIONS / DESCRIPTION	MIN	NOM	MAX	UNITS
Output Voltage Adjustment Range	An additional 1.0 Volt is provided to the output terminals to provide for load lead losses	45.6	48	50.4	V
Output Power	Continuous duty rating			7000	W
Output Current	Continuous duty rating			145	A
Efficiency	Full rated load (208 VAC)	88	91		%
Regulation	Load, Maximum deviation with 0 to 100% load change: With Remote Sense connected: With Remote Sense not connected: Utilizing Droop Current Share: Line, Under all specified operating conditions.			0.2	%
				0.75	
				2.0	
				0.2	
Ripple & Noise	Measured at mating connector w/ 0.01 μ F + 10 μ F Tant			1 2	% p-p
		20 MHz BW 100 MHz BW			
Overshoot / Undershoot	Output voltage overshoot/undershoot at turn-on			0	%
Minimum Loads	Minimum loading required to maintain regulation		0		A
Transient Response	Maximum recovery time, to within 1% of initial set point due to a 25% load change, 1A/ μ S.	Time		800	μ s
		Deviation		3.2	%
Turn-On Delay	Time required for initial output voltage stabilization after power-up			3	s
Turn-on Rise Time	Time required for output voltage to rise from 10% to 90%			100	ms

¹ With Remote Sense connected.

² User-selectable input voltage ranges

³ Please contact Bel Power Solutions for availability, if non-RoHS version FXC7000-48-S is needed

FXC7000 Series

INTERFACE SIGNALS AND PROTECTION

PARAMETER ^{4,5}	CONDITIONS / DESCRIPTION	MIN	NOM	MAX	UNITS
AC Power Fail Warning	Warning provided prior to Vout dropping 5% after loss of AC input	4			ms
Auxiliary Power	Output voltage - diode isolated. Inclusive of line, load, and initial tolerances.	11.6	12.0	12.4	V
	Output current:			500	mA
Current Monitor	Monitor output current over a compliance range of 0~10 V.				
	Normal output:		0.10		mA/A
	Total error current:	0.5		0.5	mA
Current Share	Static sharing deviation as a percent of full-load rating for loads >10%.				
	Active			5	%
	Passive			10	%
Input Range Select Status	Maximum signal resistance in high input voltage range selection.			0.10	Ω
Loss of Phase Warning	Warning provided prior to protective reduction in current limit.	500			ms
Output Inhibit	Voltage required to enable supply (0.5 mA sink) ⁶			1.0	V
Output Interlock	Voltage required to enable supply (6 mA sink) ⁵			1.0	V
Output Overload Protection	Straight line current limit (above approx. 5V Vout).	149		156	A
Output Overload Warning	Signal level on overload.	2.2			V
Output Short Circuit Protection	Occurs on overload when Vout is below approx. 5V. May operate in burst-mode.	lavg: 25		90	A
Output Voltage Fault Signal	Deviation from adjusted Vout that is considered as a fault.	±3	±4	±5	%
Output Voltage Margin	Output voltage swing available through Margin pin (analog).	±4.8	±5.0	±5.2	%
Overtemperature/ Fan Failure Warning	Time between fault warning and shutdown. Latching shutdown	100			ms
Overvoltage Protection	Latch style overvoltage protection	55.2	57.6	60.0	V
Power Supply Present Signal	Resistance to logic ground upon insertion of supply.		1000		Ω
Remote Sense	Maximum load lead loss compensation (round trip).			1.0	V

SAFETY, REGULATORY AND EMI SPECIFICATIONS

PARAMETER	CONDITIONS / DESCRIPTION	MIN	NOM	MAX	UNITS
Agency Approvals	Approved to the latest edition of the following standards: UL/CSA60950-1, IEC60950-1 and EN60950-1. CE marked for the Low Voltage Directive.				
Electromagnetic Interference	FCC CFR title 47 Part 15 Sub-Part B - Conducted	A			Class
	EN55022 / CISPR 22 Conducted	A			Class
ESD Susceptibility	Per EN61000-4-2, level 4	8			kV
Radiated Susceptibility	Per EN61000-4-3, level 3	10			V/M
EFT/Burst	Per EN61000-4-4, level 4	±4			kV
Input Transient Protection	Per EN61000-4-5	Line-to-Line	4		kV
		Line-to-Ground	3		kV
Voltage Sag Immunity	Per SEMI F47-0200 FXC/FXP6000			Pending	
Leakage Current	Per UL60950 and EN60950	FXC7000 at 240 VAC, 60 Hz		5	mA
		FXC7000 at 400 VAC, 50 Hz		7	mA
		FXC7000 at 480 VAC, 60 Hz		10	mA

⁴ All logic outputs listed below feature a standard active pull-down output with 0.4V max at 40 mA sink capability, and a 100k pull-up to 5V.

⁵ In addition to those listed below, signals and front-panel LEDs are provided to indicate: overtemperature / fan fault, AC phase imbalance, output good, interlock open, and supply inhibited. The FXC also provides 4 LED's indicating output loading.

⁶ **Both signals must be pulled to logic ground for the unit to operate.** Enables are 100% redundant internally for applications where redundant inhibit is desirable. Contact factory for additional design details.

+1.866.513.2839

tech.support@psbel.com

belpowersolutions.com

FXC7000 Series

ENVIRONMENTAL SPECIFICATIONS

PARAMETER	CONDITIONS / DESCRIPTION	MIN	NOM	MAX	UNITS
Altitude	Operating			10k	ASL Ft.
	Non-Operating			40k	ASL Ft.
Operating Temperature	At 100% load:	0		40	°C
	At 50% load:			70	°C
Storage Temperature		-40		85	°C
Temperature Coefficient	0°C to 70°C (after 15-minute warm-up)			.02	%/°C
Relative Humidity	Non-Condensing			95	%RH
Shock	Operating: half-sine 10 ms, 3 axis			+20	Gpk
	Non-operating: half-sine 10 ms, 3 axis			+40	Gpk
Vibration	Operating: swept sine 5-2000-5 Hz, 5-32 Hz, 0.02iDA, 32-2000 Hz			1	Gpk
	Non-operating: random 10-2000 Hz			6.15	Grms
Airflow	Airflow provided through the supply from front to rear.		155		cfm
			4.4		m ³ /min
			555		lfm
			2.8		m/s

MECHANICAL SPECIFICATIONS

PARAMETER	CONDITIONS / DESCRIPTION	MIN	NOM	MAX	UNITS
Mechanical Size	15.17" x 8.00" x 5.00" (385.3 mm x 203.2 mm x 127.0 mm)				
Weight	27 lb (12 kg)				

Figure 1 - Rear and Front Views for FXC7000

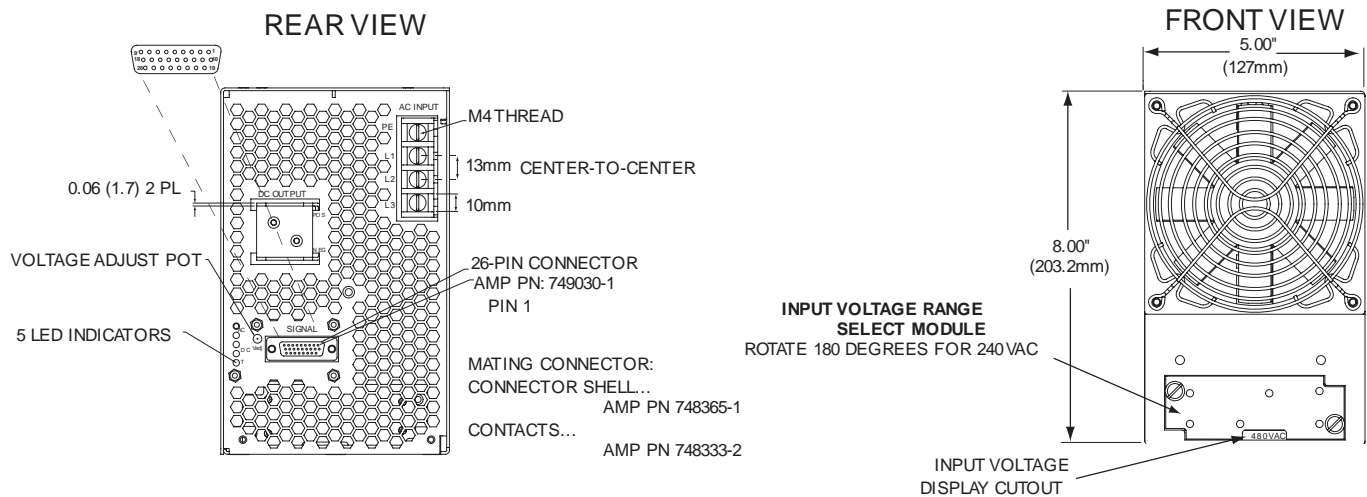

+1.866.513.2839
 tech.support@psbel.com
belpowersolutions.com

FXC7000 Series

Figure 2 - FXC7000 Overall Size

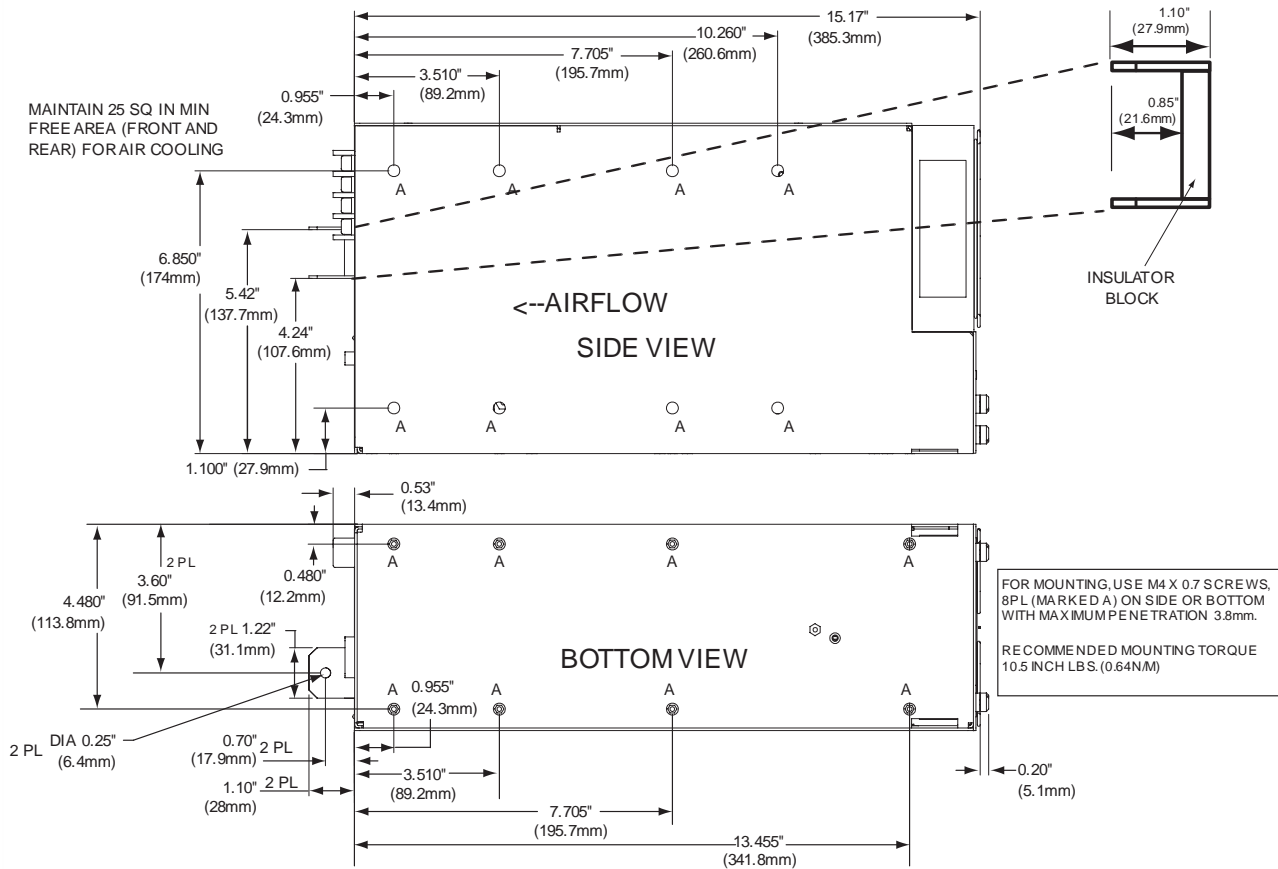

For more information on these products consult: tech.support@psbel.com

NUCLEAR AND MEDICAL APPLICATIONS - Products are not designed or intended for use as critical components in life support systems, equipment used in hazardous environments, or nuclear control systems.

TECHNICAL REVISIONS - The appearance of products, including safety agency certifications pictured on labels, may change depending on the date manufactured. Specifications are subject to change without notice.



Компания «ЭлектроПласт» предлагает заключение долгосрочных отношений при поставках импортных электронных компонентов на взаимовыгодных условиях!

Наши преимущества:

- Оперативные поставки широкого спектра электронных компонентов отечественного и импортного производства напрямую от производителей и с крупнейших мировых складов;
- Поставка более 17-ти миллионов наименований электронных компонентов;
- Поставка сложных, дефицитных, либо снятых с производства позиций;
- Оперативные сроки поставки под заказ (от 5 рабочих дней);
- Экспресс доставка в любую точку России;
- Техническая поддержка проекта, помощь в подборе аналогов, поставка прототипов;
- Система менеджмента качества сертифицирована по Международному стандарту ISO 9001;
- Лицензия ФСБ на осуществление работ с использованием сведений, составляющих государственную тайну;
- Поставка специализированных компонентов (Xilinx, Altera, Analog Devices, Intersil, Interpoint, Microsemi, Aeroflex, Peregrine, Syfer, Eurofarad, Texas Instrument, Miteq, Cobham, E2V, MA-COM, Hittite, Mini-Circuits, General Dynamics и др.);

Помимо этого, одним из направлений компании «ЭлектроПласт» является направление «Источники питания». Мы предлагаем Вам помощь Конструкторского отдела:

- Подбор оптимального решения, техническое обоснование при выборе компонента;
- Подбор аналогов;
- Консультации по применению компонента;
- Поставка образцов и прототипов;
- Техническая поддержка проекта;
- Защита от снятия компонента с производства.



Как с нами связаться

Телефон: 8 (812) 309 58 32 (многоканальный)

Факс: 8 (812) 320-02-42

Электронная почта: org@eplast1.ru

Адрес: 198099, г. Санкт-Петербург, ул. Калинина, дом 2, корпус 4, литера А.