

# ProtoBox-1593Q Kit (PCB+Box)



*A Hammond 1593Q handheld plastic enclosure with battery compartment, packaged with a matching BPS ProtoBoard 2-hole per strip PCB.*









**BusBoard Prototype Systems** - Built for designers

[www.BusBoard.com](http://www.BusBoard.com) [sales@busboard.com](mailto:sales@busboard.com)

BPS-MAR-(KIT-1593Q)-001 Rev 4.00

## Hammond Battery Holders (Sold Separately by Hammond)

Hammond Part #	Battery Holder Kit	Battery Holder Kit Includes
<p><b>BH1AAW</b></p> <p>Single AA Battery</p>		<ul style="list-style-type: none"> <li>• Battery holder for one AA battery</li> <li>• Wire leads</li> <li>• Double sided tape backing</li> <li>• Battery NOT included</li> </ul>
<p><b>BH2AAW</b></p> <p>Double AA Batteries</p>		<ul style="list-style-type: none"> <li>• Battery holder for two AA batteries</li> <li>• Wire leads</li> <li>• Foam with adhesive tape on one side</li> <li>• Divider for 1599 series - NOT included</li> <li>• Battery NOT included</li> </ul>
<p><b>BH1AAW</b></p> <p>Single AAA Battery</p>		<ul style="list-style-type: none"> <li>• Battery holder for one AAA battery</li> <li>• Wire leads</li> <li>• Double sided tape backing</li> <li>• Battery NOT included</li> </ul>
<p><b>BH2AAW</b></p> <p>Double AAA Batteries</p>		<ul style="list-style-type: none"> <li>• Battery holder for two AAA batteries</li> <li>• Wire leads</li> <li>• Double sided tape backing</li> <li>• Batteries NOT included</li> </ul>
<p><b>BH3AAW</b></p> <p>Triple AAA Batteries</p>		<ul style="list-style-type: none"> <li>• Battery holder for three AAA batteries</li> <li>• Wire leads</li> <li>• Double sided tape backing (two strips)</li> <li>• Batteries NOT included</li> </ul>
<p><b>BH4AAW</b></p> <p>Quad AAA Batteries</p>		<ul style="list-style-type: none"> <li>• Battery holder for four AAA batteries</li> <li>• Wire leads</li> <li>• Foam with adhesive tape on one side</li> <li>• Divider for 1599 series - NOT included</li> <li>• Batteries NOT included</li> </ul>
<p><b>BS61</b></p> <p>Single 9 Volt Battery</p>		<ul style="list-style-type: none"> <li>• Battery holder for one 9V battery</li> <li>• Wire leads</li> <li>• Foam with adhesive tape on one side</li> <li>• Dividers for 1599 series - NOT included</li> <li>• Battery NOT included</li> </ul>



*A prototyping board designed for the Hammond 1593Q handheld enclosure with battery compartment.*

## Features

*ProtoBoard* saves time! The PCB is designed specifically for the Hammond 1593Q box. No cutting is required. The mounting holes are present in the right spots.

The convenient 2-hole ProtoBoard pattern provides an easy way to connect parts while maximizing usable board area.

**Lead free** etched copper PCB with an anti-tarnish coating for easy soldering.

## PCB Specifications

- High-quality FR4 glass epoxy board.
- Four 0.125" (1/8") mounting holes.
- Four 4-40 PCB mounting screws provided.
- Single sided, 1oz/ft<sup>2</sup> copper PCB
- 0.042" holes drilled on 0.1" centers
- PCB Size 2.4 x 2.7 in. (62 x 69mm)

**Order Part# PR1593Q (for PCB only)**

## Board Layout (actual size)

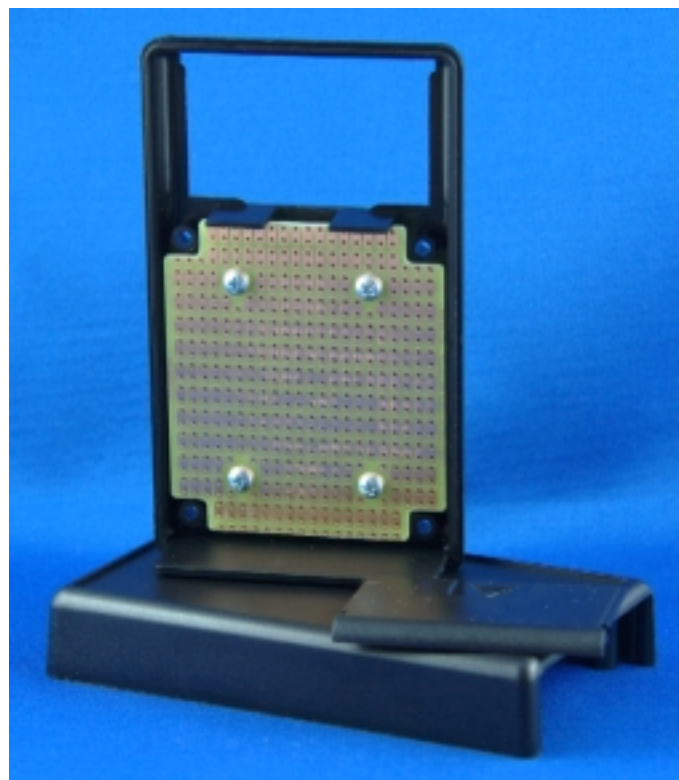
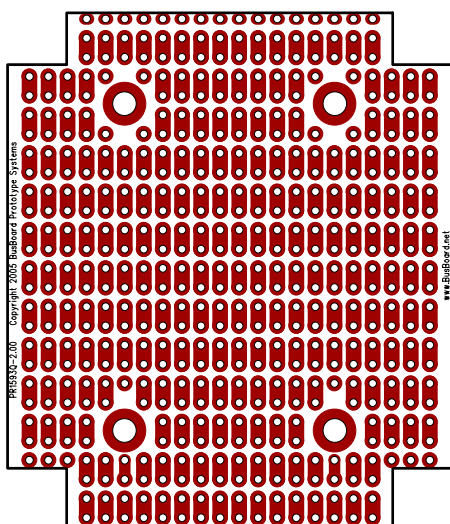

**PR1593Q Prototyping Board shown with the Hammond 1593QBK box (box not included).**

**To purchase the PCB + Box together, order BPS part# KIT-1593Q-BK**



### Top View of Assembly

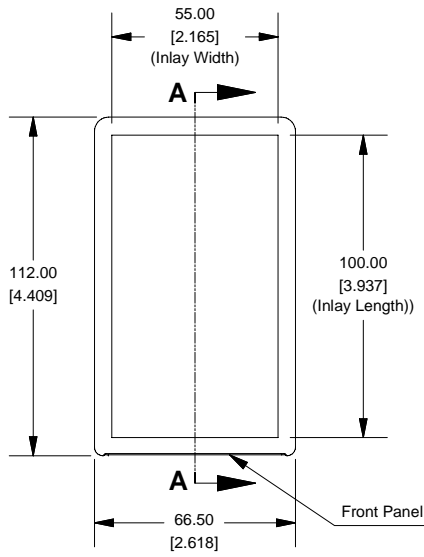

### SECTION A-A (Side View Inside Assembly)

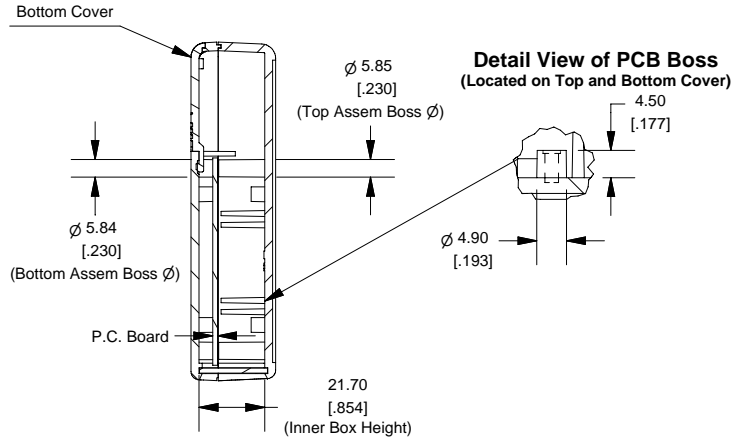

## Hand Held Instrument (1593Q)

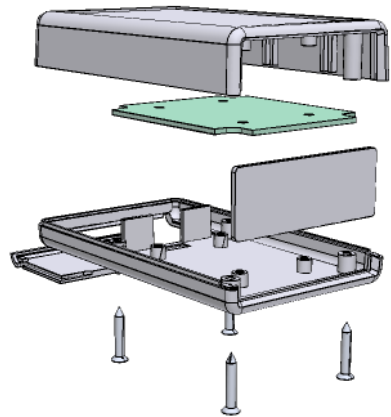

### End View of Assembly

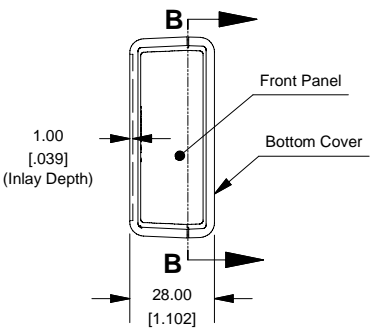

### SECTION B-B (Inside of Bottom Cover)

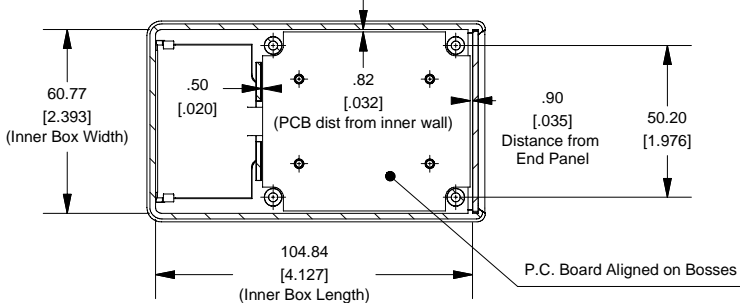

### Front/Rear Panel (Dashed Line Indicates Viewing Area)

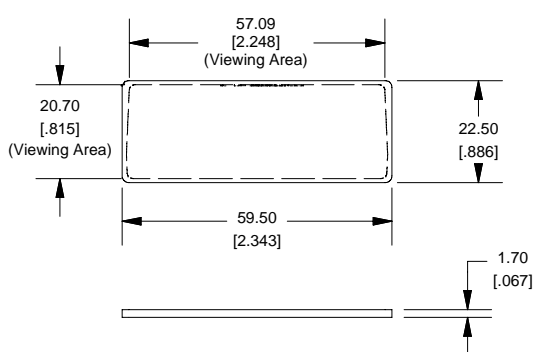

### Maximum P.C. Board Size

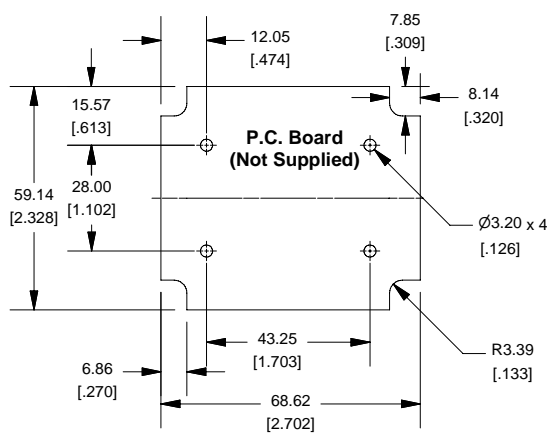

Enclosures can be Factory Modified ( Milling, Drilling, Printing etc. )  
 Solid models of this enclosure available in STEP or IGES.  
 Contact Factory [mjm@hammondmfg.com](mailto:mjm@hammondmfg.com)

NOTE	
Enclosure molded from GP ABS (UL94-HB) plastic.	
Purchased assembly includes top and bottom cover, front panel (plastic), battery door and 4 cover screws.	

PART NUMBERS	
<b>1593Q Enclosure</b>	
Black Enclosure	1593QBK
Grey Enclosure	1593QGY
<b>ACCESSORIES</b>	
Cover Screws (Pkg 100)	1593QS100 (Silver)
#4 x 3/4" self-tapping oval head (19.1mm)	1593QS100BK (Black)
P.C. Board Screws	1593ATS50 (Pkg 50)
#4 x 1/4" self-tapping (6.4mm)	1593ATS100 (Pkg 100)
Belt or Pocket Clip	1599CLIP (Black)
	1599CLIPGY (Grey)
Infrared Panels (Pkg 10)	1593DIR10

**HAMMOND  
MANUFACTURING™**

**1593Q**

[www.hammondmfg.com](http://www.hammondmfg.com)



Компания «ЭлектроПласт» предлагает заключение долгосрочных отношений при поставках импортных электронных компонентов на взаимовыгодных условиях!

Наши преимущества:

- Оперативные поставки широкого спектра электронных компонентов отечественного и импортного производства напрямую от производителей и с крупнейших мировых складов;
- Поставка более 17-ти миллионов наименований электронных компонентов;
- Поставка сложных, дефицитных, либо снятых с производства позиций;
- Оперативные сроки поставки под заказ (от 5 рабочих дней);
- Экспресс доставка в любую точку России;
- Техническая поддержка проекта, помощь в подборе аналогов, поставка прототипов;
- Система менеджмента качества сертифицирована по Международному стандарту ISO 9001;
- Лицензия ФСБ на осуществление работ с использованием сведений, составляющих государственную тайну;
- Поставка специализированных компонентов (Xilinx, Altera, Analog Devices, Intersil, Interpoint, Microsemi, Aeroflex, Peregrine, Syfer, Eurofarad, Texas Instrument, Miteq, Cobham, E2V, MA-COM, Hittite, Mini-Circuits, General Dynamics и др.);

Помимо этого, одним из направлений компании «ЭлектроПласт» является направление «Источники питания». Мы предлагаем Вам помощь Конструкторского отдела:

- Подбор оптимального решения, техническое обоснование при выборе компонента;
- Подбор аналогов;
- Консультации по применению компонента;
- Поставка образцов и прототипов;
- Техническая поддержка проекта;
- Защита от снятия компонента с производства.



#### Как с нами связаться

**Телефон:** 8 (812) 309 58 32 (многоканальный)

**Факс:** 8 (812) 320-02-42

**Электронная почта:** [org@eplast1.ru](mailto:org@eplast1.ru)

**Адрес:** 198099, г. Санкт-Петербург, ул. Калинина, дом 2, корпус 4, литера А.