

CATALOG NO.	TERMINAL TYPE	IP20 FINGER SAFE COVERS		NO. OF POLES
		W/O INDICATION	INDICATION	
BCM603-1SQ	SCREW W/ QUICK CONNECT			1
BCM603-2SQ	SCREW W/ QUICK CONNECT	CVR-CCM-QC SEE NOTES 7 & 9	CVRI-CCM-QC SEE NOTES 7 & 9	2
BCM603-3SQ	SCREW W/ QUICK CONNECT			3
BCM603-1PQ	PRESSURE PLATE W/ QUICK CONNECT			1
BCM603-2PQ	PRESSURE PLATE W/ QUICK CONNECT	CVR-CCM-QC SEE NOTES 7 & 9	CVRI-CCM-QC SEE NOTES 7 & 9	2
BCM603-3PQ	PRESSURE PLATE W/ QUICK CONNECT			3
BCM603-1S	SCREW			1
BCM603-2S	SCREW	CVR-CCM SEE NOTES 8 & 9	CVRI-CCM SEE NOTES 8 & 9	2
BCM603-3S	SCREW			3
BCM603-1P	PRESSURE PLATE			1
BCM603-2P	PRESSURE PLATE	CVR-CCM SEE NOTES 8 & 9	CVRI-CCM SEE NOTES 8 & 9	2
BCM603-3P	PRESSURE PLATE			3
BCM603-1C	BOX LUG			1
BCM603-2C	BOX LUG	CVR-CCM SEE NOTES 8 & 9	CVRI-CCM SEE NOTES 8 & 9	2
BCM603-3C	BOX LUG			3

REVISIONS					
REV	ZONE	DESCRIPTION	DATE	ECN	BY
A		PRE-RELEASE	5/8/14	BU-SB14TBD	AVM

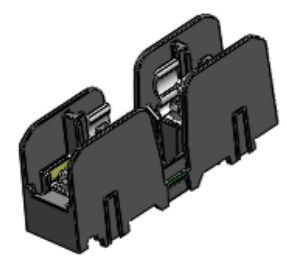

3D VIEW FOR BCM603-1S  
SCALE NONE

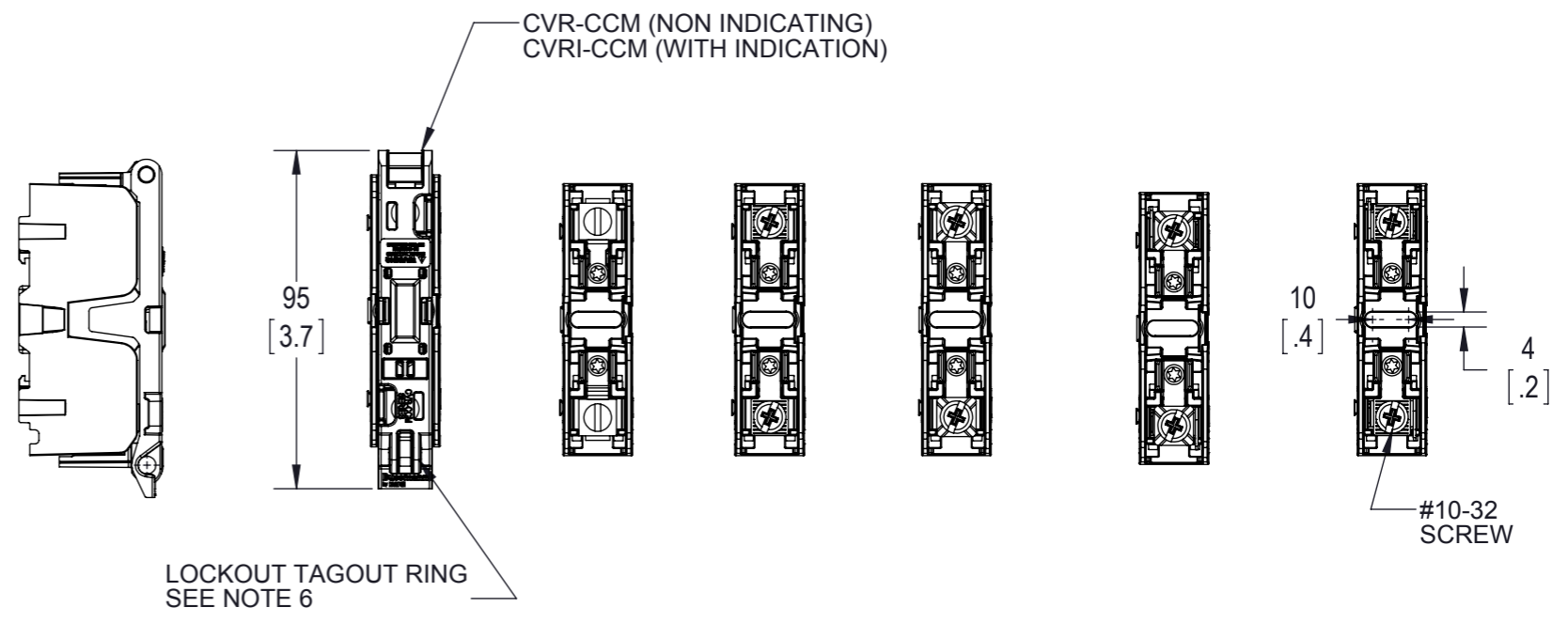
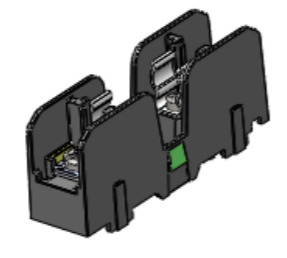

3D VIEW FOR BCM603-1P  
SCALE NONE

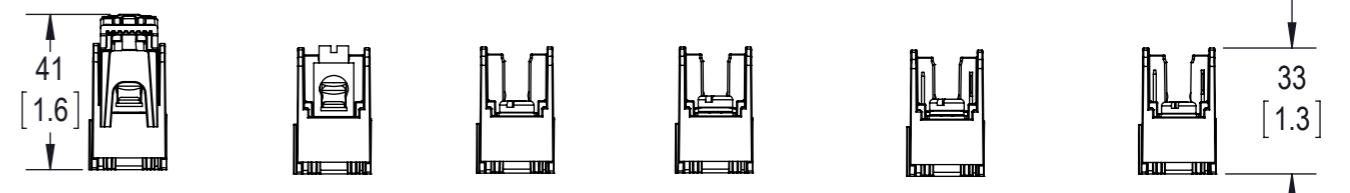

BCM603-1C WITH COVER    BCM603-1C    BCM603-1S    BCM603-1P    BCM603-1PQ    BCM603-1SQ

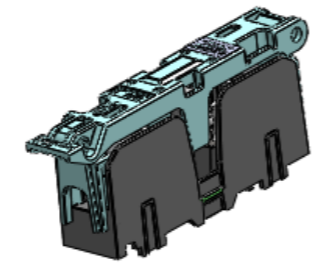

3D VIEW FOR BCM603-1C  
WITH COVER CVRI-CCM  
SCALE NONE

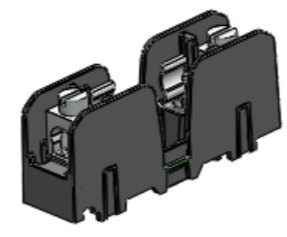

3D VIEW FOR BCM603-1C  
SCALE NONE

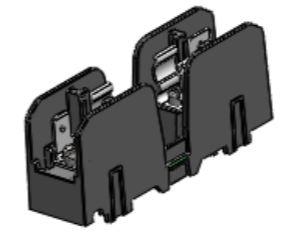

3D VIEW FOR BCM603-1SQ  
SCALE NONE

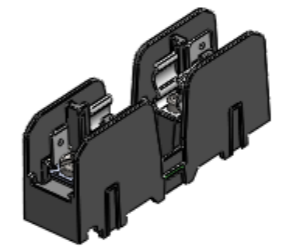

3D VIEW FOR BCM603-1PQ  
SCALE NONE

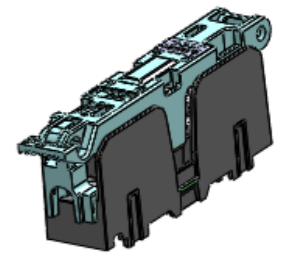

3D VIEW FOR BCM603-1xQ  
WITH COVER CVRI-CCM-QC  
SCALE NONE

CUSTOMER PRINT

- NOTES:
- VOLTAGE RATING: 600V
  - AMPERAGE: 30A (20A QUICK CONNECT)
  - WITHSTAND RATING: 200kA
  - C: WIRE RANGE:
    - (1) CU 75/90C
      - 2-3 AWG = 50 LB-IN (5.6NM)
      - 4-6 AWG = 45 LB-IN (5.1NM)
      - 8-14 AWG = 35 LB-IN (4.0 NM)
    - (1) AL 75/90C
      - 2-6 AWG = 50 LB-IN (5.6NM)
      - 8 AWG = 40 LB-IN (4.5NM)
  - S/P/SQ/PQ WIRE RANGE: (1) CU 75/90C
    - 10-18 AWG = 20 LB-IN (2.3NM)
  - USE 4MM DIA. CABLE LOCK
  - CVR-CCM-QC AND CVRI-CC-QC
    - 10AWG MAX WIRE + QUICK CONNECT OPENINGS AT ENDS AND TOP
  - CVR-CCM AND CVRI-CCM
    - 4AWG MAX WIRE + QUICK CONNECT OPENINGS AT TOP ONLY
    - FITS WITH MOST RING AND FORK CONNECTORS
  - ALL COVERS FIT ON ALL BASES
  - RECOMMEND USING DIN-RAIL END STOPS FOR DIN RAIL MOUNTED APPLICATIONS
    - BUSSMANN PART NUMBERS BRKT-ND OR BRKT-NDSREW2
  - USE BUSSMANN MARKER LABEL TM26CB
  - ALL DIMENSIONS ARE TYPICAL UNLESS OTHERWISE INDICATED

MODEL SOURCE DATA BMM603-XPQ	MODEL VERSION	GENERAL DRAWING PRACTICES IN ACCORDANCE WITH ASME - Y14.100-2004 DIMENSIONS AND TOLERANCES IN ACCORDANCE WITH ASME - Y14.5M-1994	APPROVALS D. McDowell A. VZM	DATE 5/08/2014 5/08/2014	
THIS DRAWING IS AN UNCONTROLLED COPY IF PRINTED OR SENT ELECTRONICALLY. DO NOT SCALE DRAWING.		UNLESS OTHERWISE SPECIFIED DIMENSIONS ARE IN MILLIMETERS TOLERANCES TO BE ONE PLACE X.X = ±0.3mm TWO PLACE X.X X = ±0.13mm ALL ANGLES X.X = ±1°	QUALITY ---	---	
EATON CORPORATION - CONFIDENTIAL AND PROPRIETARY NOTICE TO PERSONS RECEIVING THIS DOCUMENT AND/OR TECHNICAL INFORMATION THIS DOCUMENT, INCLUDING THE DRAWING AND INFORMATION CONTAINED THEREON IS CONFIDENTIAL AND IS THE EXCLUSIVE PROPERTY OF EATON CORPORATION AND IS MERELY ON LOAN AND SUBJECT TO RECALL BY EATON AT ANY TIME. BY TAKING POSSESSION OF THE DOCUMENT, THE RECIPIENT ACKNOWLEDGES AND AGREES THAT EATON AND THAT NO PORTION OF THIS DOCUMENT MAY BE COPIED OR OTHERWISE REPRODUCED WITHOUT THE PRIOR WRITTEN CONSENT OF EATON. IN THE CASE OF CONFLICTING CONTRACTUAL PROVISIONS, THIS NOTICE SHALL GOVERN THE STATUS OF THIS DOCUMENT.		SPECIAL CHARACTERISTIC $\diamond (0)$ SIGNIFICANT CHARACTERISTIC $\triangle (0)$	MATERIAL N/A	FINISH N/A	<b>600V / 30A 10X38 CC FUSE BLOCK</b> <b>BCM603-SERIES-CP</b>
© 2012 Eaton Corporation. All Rights Reserved.		THIRD ANGLE PROJECTION	SCALE: 1:2	SHEET 1 OF 3	REV A

8 7 6 5 4 3 2 1

F  
E  
D  
C  
B  
A

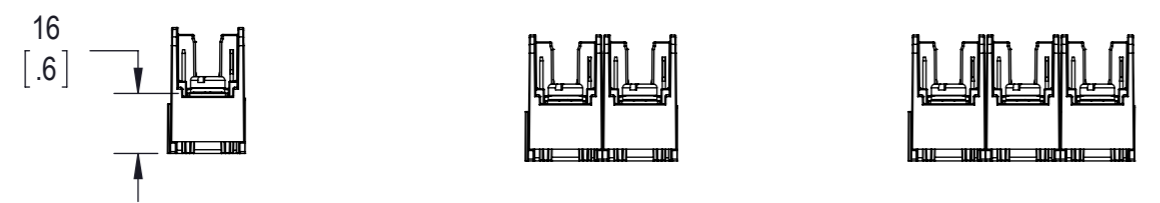
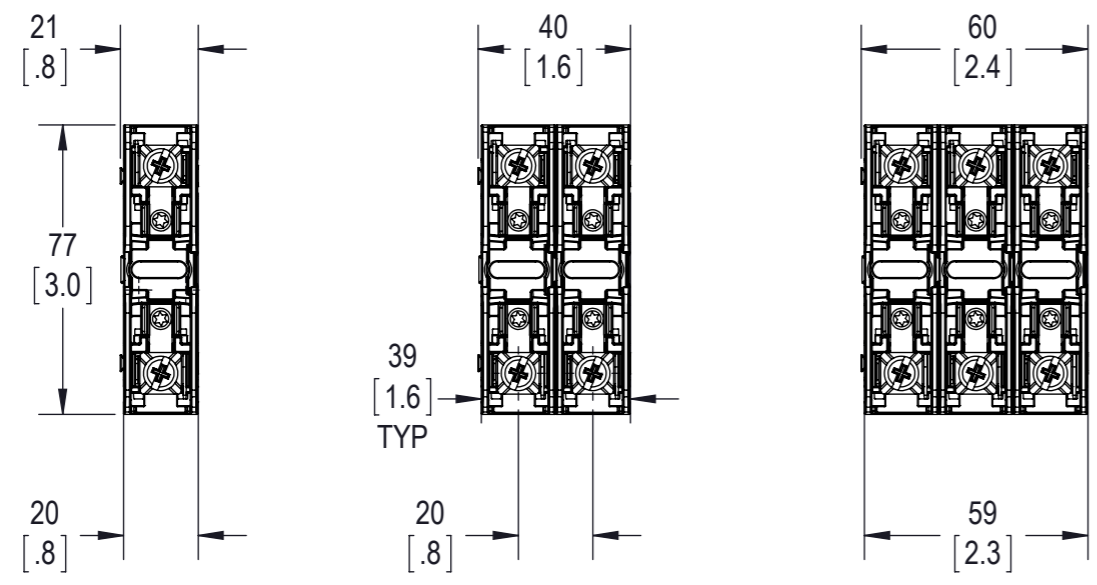

1 POLE  
BCM603-1PQ SHOWN

2 POLE  
BCM603-2PQ SHOWN

3 POLE  
BCM603-3PQ SHOWN

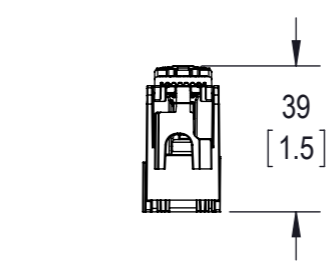
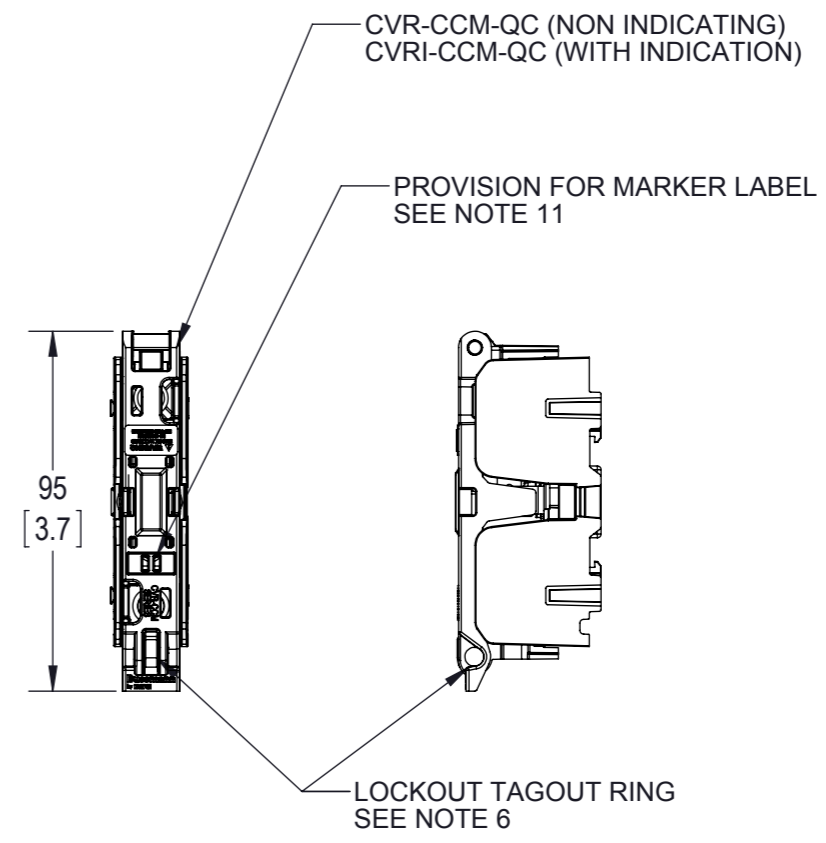

BCM60C-1xQ  
SHOWN WITH COVER

CUSTOMER PRINT

**Bussmann**  
by **E.T.N.**

TITLE 600V / 30A 10X38 CC FUSE BLOCK		
SIZE <b>A3</b>	DWG NO. <b>BCM603-SERIES-CP</b>	REV <b>A</b>
SCALE: 1:2	SHEET 2 OF 3	

8 7 6 5 4 3 2 1

THIS SECTION MAY BE CUT OUT FOR USE WITH VERTICALLY ORIENTED QUICK CONNECTS



PUSH COVER PIVOT AND END PIECE SNAPS INTO SLOTS IN BASE. THE COVER MAY BE ORIENTED IN EITHER DIRECTION.

**COVER INSTALLATION**  
ONCE INSTALLED THE COVER CANNOT BE REMOVED



**OPENING AND CLOSING**  
PUSH/PULL ON END TAB, ROTATE UNTIL CLOSED/OPEN

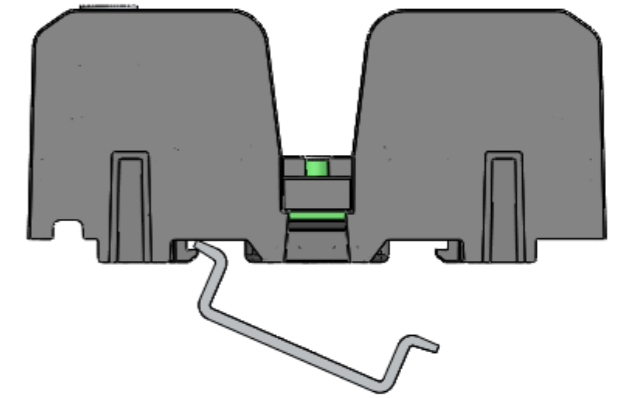

1. HOOK DIN RAIL SNAPS ON ONE SIDE OF THE DIN RAIL

2. PUSH DOWN TO DEFLECT THE SNAPS

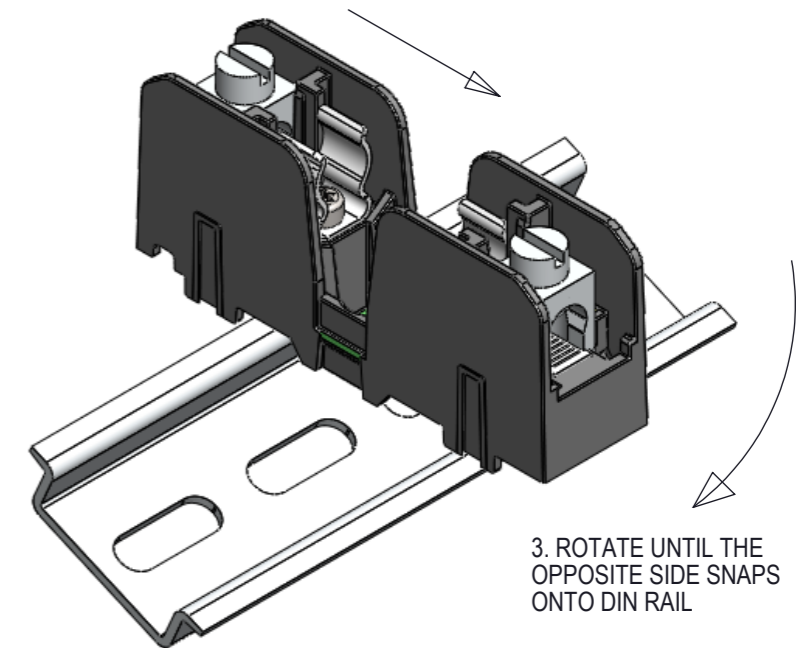

3. ROTATE UNTIL THE OPPOSITE SIDE SNAPS ONTO DIN RAIL

**INSTALLATION ON DIN RAIL**  
END STOPS MAY BE NECESSARY FOR SOME ASSEMBLY CONDITIONS - SEE NOTE 10

CUSTOMER PRINT

**Bussmann**  
by **E.T.N.**

TITLE  
600V / 30A 10X38 CC FUSE BLOCK

SIZE DWG NO. REV  
**A3** **BCM603-SERIES-CP** **A**

SCALE: 1:2 SHEET 3 OF 3



Компания «ЭлектроПласт» предлагает заключение долгосрочных отношений при поставках импортных электронных компонентов на взаимовыгодных условиях!

Наши преимущества:

- Оперативные поставки широкого спектра электронных компонентов отечественного и импортного производства напрямую от производителей и с крупнейших мировых складов;
- Поставка более 17-ти миллионов наименований электронных компонентов;
- Поставка сложных, дефицитных, либо снятых с производства позиций;
- Оперативные сроки поставки под заказ (от 5 рабочих дней);
- Экспресс доставка в любую точку России;
- Техническая поддержка проекта, помощь в подборе аналогов, поставка прототипов;
- Система менеджмента качества сертифицирована по Международному стандарту ISO 9001;
- Лицензия ФСБ на осуществление работ с использованием сведений, составляющих государственную тайну;
- Поставка специализированных компонентов (Xilinx, Altera, Analog Devices, Intersil, Interpoint, Microsemi, Aeroflex, Peregrine, Syfer, Eurofarad, Texas Instrument, Miteq, Cobham, E2V, MA-COM, Hittite, Mini-Circuits, General Dynamics и др.);

Помимо этого, одним из направлений компании «ЭлектроПласт» является направление «Источники питания». Мы предлагаем Вам помощь Конструкторского отдела:

- Подбор оптимального решения, техническое обоснование при выборе компонента;
- Подбор аналогов;
- Консультации по применению компонента;
- Поставка образцов и прототипов;
- Техническая поддержка проекта;
- Защита от снятия компонента с производства.



#### Как с нами связаться

**Телефон:** 8 (812) 309 58 32 (многоканальный)

**Факс:** 8 (812) 320-02-42

**Электронная почта:** [org@eplast1.ru](mailto:org@eplast1.ru)

**Адрес:** 198099, г. Санкт-Петербург, ул. Калинина, дом 2, корпус 4, литера А.