

**Table of Contents**

**Introduction** . . . . .3-2 to 3-3

**Expanded Beam Products**

    MIL Qualified Connectors (MIL-DTL-83526) . . . . .3-4

    Pro Beam Mini Connectors . . . . .3-5 to 3-7

    Pro Beam Jr. Connectors . . . . .3-8 to 3-11

    Pro Beam Sr. Connectors . . . . .3-12, 3-13

    38999 Series III Style Connectors . . . . .3-14 to 3-16

    Expanded Beam Contact (Size 16) . . . . .3-17

    Cable Assemblies and Accessories . . . . .3-18 to 3-19

        Cables

        Reels

        Backpacks

    Tactical Optical Cable . . . . .3-20

    Commercial Fiber Optic Mechanical Splice Kits . . . . .3-21

    Optical Test Set for Fiber Optic Cables . . . . .3-22

    Hand Held Fault Locator . . . . .3-23

    Expanded Beam Avionics-Related Standards and Specifications . . . . .3-24

    ARINC 600 and 404 . . . . .3-25 to 3-28

**Physical Contact & Technology**

    ARINC 801 Optical Termini . . . . .3-29 to 3-30

    F12 ARINC 801 Insert Assemblies . . . . .3-31

    ARINC 801 Optical Termini Adapter Dimensions . . . . .3-32

    ARINC 801 Optical Termini Termination Kit . . . . .3-33

    MIL-T-29504 . . . . .3-34

    Optical Inserts for EN4165 and ARINC 809 . . . . .3-34

    Fiber Optic Insert for DMC-M . . . . .3-34

    RSC-v . . . . .3-34

**Rugged Circular Connectors**

    38999 Style Connectors . . . . .3-35

    MC3 . . . . .3-36 to 3-39

    MC4 . . . . .3-40 to 3-41

    MC5 . . . . .3-42 to 3-45

    MC6 . . . . .3-46 to 3-48

    MC801 . . . . .3-49

    Ruggedized Singleway Connector (RSC) . . . . .3-50 to 3-52

    Sealed Circular LC ODVA . . . . .3-53

    Empire . . . . .3-54

**Rugged Board Level Connectors**

    Ruggedized Optical Backplane Interconnect for VITA 66.1 . . . . .3-55

**Navy CID Approved - Epoxy Applied**

    Tight Jacketed LC Connectors . . . . .3-56

    Tight Jacketed SC Connectors . . . . .3-57

**LightCrimp Plus Navy Approved**

    LC, SC and LightCrimp Plus ST Approved by US Navy . . . . .3-58

    Combination LightCrimp Plus Termination Kit . . . . .3-59

    LightCrimp Splice . . . . .3-60

**Offshore Optical Connectors and Cable Assemblies** . . . . .3-61



**Ruggedized Fiber Optic Products**

**Product Facts**

- **Expanded Beam**
  - PRO BEAM Sr.Connectors
  - PRO BEAM Jr.Connectors
  - PRO BEAM Mini Connectors
  - Mini 38999
  - Mini ARINC
  - Mini GPRC
  - Size 16 M29504 EB/4 and /5 varieties

**Physical Contact Technology**

- ARINC 801 MM and SM
- M29504 /4 and /5 MM and SM
- MC Series
  - MC3
  - MC3
  - MC5
  - MC6
  - MC801
- Rugged Single Channel (RSC)
- Sealed Circular LC ODVA Conforming Connector

TE Connectivity (TE) is proud to offer a full ruggedized fiberoptic product family. With TE's complete selection that includes world class Physical Contact and Expanded Beam technologies that include MC series of high density contact, a Rugged Single Channel and MT ribbon fiber as well as global industry standards of EN4165 and ARINC 801 along with our M83526/20 and /21 qualified products and wide variety of Expanded Beam technologies the end user is guaranteed a complete choice that meets their cost and optical performance needs in multiple industries.

For specific information, please contact your local TE Sales Representative.

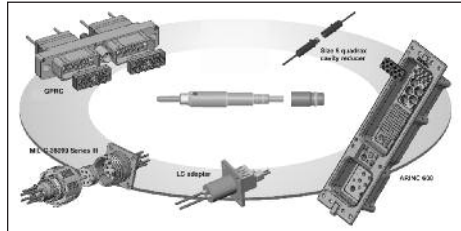

ARINC 801 Optical Termini



Expanded Beam Products



MC5 (JN1130) multiway connectors



EN4165 derivatives



MC4



MC3 (JN1146) multiway connectors



MIL-T-29504



RSC (JN1148) single way connector



MC6

**ASSEMBLY CAPABILITIES**  
 TE Connectivity has extensive Rugged Optic Harness capabilities. Please consult your local TE Sales representative for assistance.

**Ruggedized Fiber Optic Products** (Continued)

**Expanded Beam Products**

**Product Facts**

- PRO BEAM Sr., PRO BEAM Jr. and PRO BEAM Mini Connector field deployable interconnects
- ARINC 600 connectors, with inserts/holder blocks designed for Mini Expanded Beam — up to 128 channels on size 3 ARINC 600
- MIL-C-38999 Series III shell size 11 and 15 style circular connectors — Cable assemblies up to 8 fibers
- Unique Modular Design, for use with multimode and singlemode fiber
- Tactical cables, cable reels, backpacks
- Cable assembly and termination services
- Ball lens expands cross-sectional area of light over 200 times for multimode and over 2000 times for singlemode
- Rugged hermaphroditic construction (i.e., same insert mates to each other)
- Physically non-contacting mating conditions; no wear, installed fiber ferrule protected by ball lens

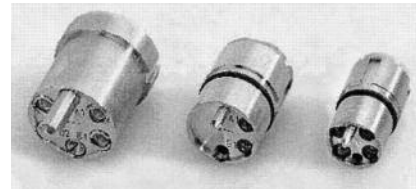

From left to right: PRO BEAM Sr., PRO BEAM Jr. & Mini Expanded Beam inserts.

**Key Features**

Fiber Optic Interconnect/Cable System using Expanded Beam technology, which physically expands and collimates the transmission signal into an optical beam over 14 times its original diameter (the cross sectional area of the light beam increases over 200 times for multimode optical signals). For singlemode signals, the collimated beam is over 45 times its

**Product Facts**

- No wear on fiber optic interface; Very vibration resistant
- Easy to handle, easy to clean. Durable connection that is highly resistant to dirt/debris
- Singlemode or multimode
- Common 850/1300 Dual Wavelength, 1310, or 1550 nm wavelengths
- Easy alignment for low-loss, repeatable performance
- Consistent overall optical “link budget” assured
- Low sensitivity to thermal fluctuations and interface contamination
- Repeatable low-loss performance in harsh environments

**Expanded Beam Technology**

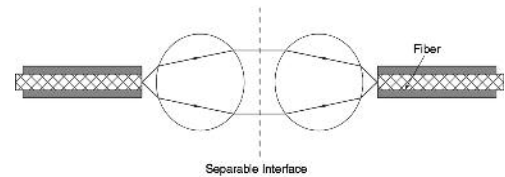

Expanded Beam Principle

original diameter (the cross-sectional area of the light beam increases over 2,000 times.). It is then refocused back down onto the core of the receiving fiber. This approach provides ease of alignment and low sensitivity to thermal changes and contamination. High strength, precision connector housings enhance a durable connection, optimizing low loss and repeatable performance.

**Applications**

Suitable for field-deployable communications, marine ship-to-shore applications, security systems, mobile diagnostic units, oil and gas exploration and other harsh environment applications demanding strength, durability and reliable performance in conditions of multiple coupling/decouplings, blindmate situations, and high vibration.

**EB termini**



- Durable non-contacting interface assures ease of use/cleaning
- Termini designed to replace existing M29504/4 and /5 physical contact termini that fits the Size 16 AWG cavity of a D389999 III connector
- MM and SM termini designs

**Expanded Beam Inserts**

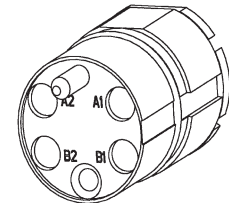

- PRO BEAM Sr. Insert — the original, larger format, Field Tactical, hermaphroditic Connector System
- PRO BEAM Jr. Insert — the second generation, reduced size, Field Tactical Connector System — a TE Connectivity original design
- Mini Expanded Beam Insert for multi-channel small form factor — the smallest expanded beam multi-channel insert in the industry, another TE Connectivity original design

Expanded Beam Products

**MIL-Qualified Connectors M83526/20 and M83526/21**

The original now has a MIL-qualified version. The benchmark PRO BEAM Jr. connector series was the model for the MIL-DTL-83526/20 and /21 specifications. TE is now the first to gain full qualification to these specifications with TE's M83526/20 and M83526/21 connectors.

**Product Facts**

- MIL-qualified to MIL-DTL-83526/20B and MIL-DTL-83526/21B
- QPD- (Qualified Products Database) listed on <http://qpldocs.dla.mil/>
- VG-approval to VG 95319-100 and -101
- Fully intermateable and interoperable with the benchmark PRO BEAM Jr. connector series
- TE's patented Interference-Fit expanded beam design technology yields unmatched high performance and high reliability

**TECHNICAL DOCUMENTS**  
**408-32093 M83526/20 Plug**  
**408-32107 M83526/21 Bulkhead**  
<http://te.com/documents>  
**Mil-DTL-83526/20B**  
**Mil-DTL-83526/21B**  
<http://quicksearch.dla.mil>

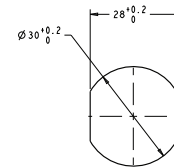
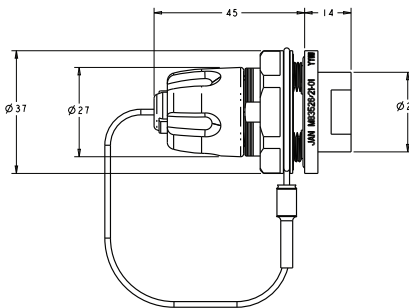
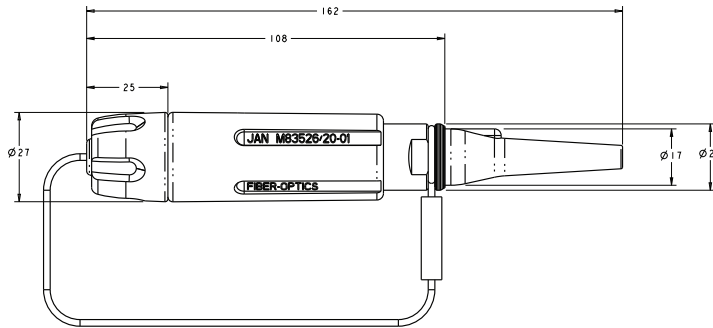

**MIL-DTL-83526 Connector Assembly Part Numbers**

P/N	Part Number	Description
M83526/20-01	2064556-1	4 x 850/1300 MM Plug
M83526/20-02	2064557-1	4 x 1310 SM Plug
M83526/20-03	2064558-1	4 x 1550 SM Plug
M83526/20-04	2064559-1	2 x 850/1300 MM Plug
M83526/20-05	2064560-1	2 x 1310 SM Plug
M83526/20-06	2064561-1	2 x 1550 SM Plug
M83526/21-01	2064562-1	4 x 850/1300 MM Bulkhead
M83526/21-02	2064563-1	4 x 1310 SM Bulkhead
M83526/21-03	2064564-1	4 x 1550 SM Bulkhead
M83526/21-04	2064565-1	2 x 850/1300 MM Bulkhead
M83526/21-05	2064566-1	2 x 1310 SM Bulkhead
M83526/21-06	2064567-1	2 x 1550 SM Bulkhead

**VG numbers assigned as reference docs. Mil spec detail sheets will be formal guidance for orders**

MIL-DTL-83426/20 = VG 95319-100
MIL-DTL-83426/21 = VG 95319-101

**MFOCA - Mixed Mode**

P/N	DLA P/N	Type	Channels	Color
1516546-1	10023-03	Plug	2 MM + 2 SM	Brown
1516547-1	10023-01	Plug	2 SM	Green
1516548-1	10023-02	Plug	2 MM	Black
1516702-1	10024-03	Bulkhead	2 MM + 2 SM	Brown
1516703-1	10024-01	Bulkhead	2 SM	Green
1516704-1	10024-02	Bulkhead	2 MM	Black

\* for cable assembly applications please contact your local TE representative

**Expanded Beam Products** (Continued)

**PRO BEAM Mini Connectors**

TE Connectivity is pleased to announce the natural extension from our PRO BEAM Sr. and Jr. Connector product lines.

The PRO BEAM Mini Connector saves space and weight and is perfect for high density applications. The product offers the same durability as its larger counterparts.



PRO BEAM Sr., Jr. & Mini Connectors



PRO BEAM Mini Plug Connector

**Connector Assembly**

- 1 Shell Kit
- 1 Insert Kit
- 1 Cable Adapter Kit\*
- X Ferrule Kits (X = No. of optical channels)

\*Not applicable for Low Profile

**PRO BEAM Mini Connector Shell Kits**

Type	Mount Style	Attribute Difference	Part Number			
			(HA Aluminum)	(OD Aluminum)	(NiAlBronze)	(Black Aluminum)
Plug		EPDM Grip	1828698-1	N/A	1828698-2	N/A
Bulkhead	D-Hole	Low Profile - Buffered Fiber	1828699-1	1828699-2 ◆	1828699-3	1828699-4
		Low Profile - 1.8 Jacketed	1985140-1	1985140-2 ◆	1985140-3	1985140-4
		Sealed	1918185-1	1918185-3	1918185-2	1918185-4
	Square Flange	Low Profile - Buffered Fiber	1828826-1	*	*	*
		Neutrik Cutout-Drop-In	1918603-1	*	*	*

\* Contact TE for availability.

**PRO BEAM Mini Insert Kits**

Description	Part Number
2 x 850 / 1300 nm Dual Multimode	1374759-4
2 x 1310 nm Singlemode	1588129-2
2 x 1550 nm Singlemode	1588128-2
4 x 850 / 1300 nm Dual Multimode	1374759-2
4 x 1310 nm Singlemode	1588129-3
4 x 1550 nm Singlemode	1588128-3

**PRO BEAM Mini Ferrule Kits**

Fiber Hole Size	Mode	PRO BEAM Connector	Part Number
125 μm	SM	Mini	1754700-1
126 μm	SM	Mini	1754700-2
126 μm	MM	Mini	1754699-1

**PRO BEAM Mini Cable Adapter Kits For Plug**

Cable Diameter	Part Number	
	Aluminum	NiAlBronze
5.1 mm	1828700-1	1828700-5
5.6 mm	1828700-2	1828700-6
6.2 mm	1828700-3	1828700-7
6.7 mm	1828700-4	1828700-8

**PRO BEAM Mini Cable Adapter Kits For Sealed Bulkhead**

Cable Diameter	Part Number
5.1 mm	1516228-1
5.6 mm	1516228-2
6.2 mm	1516228-3

**Note:** Part Numbers are RoHS compliant except: ◆ Indicates non-RoHS compliant.



Standard color black for Polymer Grip Rings, Cap and Boots. Alternate colors available upon request.



Expanded Beam Products (Continued)

**PRO BEAM Mini Connectors**

**Performance Specifications**

**Optical, Multimode Version**  
**Insertion Loss, Typical\***—  
 0.7 dB @ 1300 nm and 850 nm dual wavelength

**Optical, Singlemode Version**  
**Insertion Loss, Typical\***—  
 0.8 dB @ 1310 nm or 1550 nm optimized wavelength

**Return Loss\*\*** — > 34 dB @ 1310 nm or 1550 nm optimized wavelength

\*When tested with reference quality launch/receive cable assemblies

\*\*RL Tested Open Ended

**Mechanical**

**Vibration, Sinusoidal** —  
 10 - 500 Hz, 3 directions;  
 0.75 mm amplitude @ 10g acceleration

**Bump** — 4,000 Bumps, 3 directions @ 40g acceleration

**Free Fall** — 500 falls on concrete; Severity 1.2 m

**Coupling Endurance** —  
 3,000 couplings

**Weight** —  
 Plug — 50 grams, typical  
 D-Hole bulkhead — 39 grams, typical

**Temperature**

**Operational Temperature** —  
 -40°C/+85°C

**Storage Temperature** —  
 -55°C/+85°C

**Temperature, Cyclic** —  
 -55°C/+85°C

**Humidity (Damp Heat)** —95% RH

**Immersion**

**Water** — 5 m depth (plug) -  
 2 m (Bulkhead)

**Pressure**

**Low Pressure** — 25 kPa @ -55°C

**Material and Finish**

**Shell Alloy** — Aluminum; or nickel aluminum bronze (high saline environment)

**Plating (For Aluminum Shells Only)** — clear hard anodized; or green chromate conversion zinc or black zinc - nickel alloy (PRO BEAM Mini Bulkheads only)

**Technical Documents**

- 408-10065 Plug
- 408-10067 Square Flange Bulkhead
- 408-10069 Low Profile D-Hole Bulkhead
- 408-10076 Sealed D-Hole Bulkhead
- <http://www.te.com/documents>

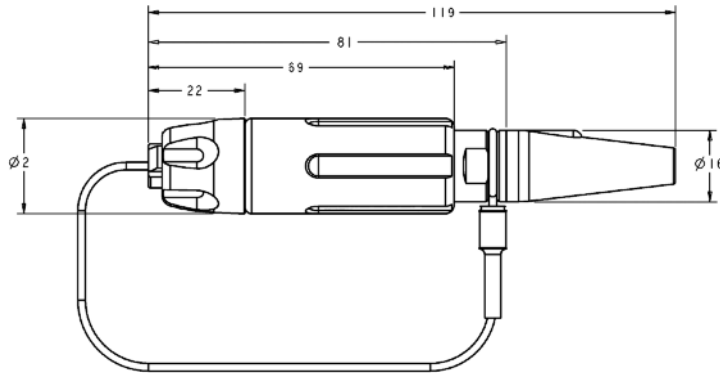

PRO BEAM Mini Cable Connector, Plug

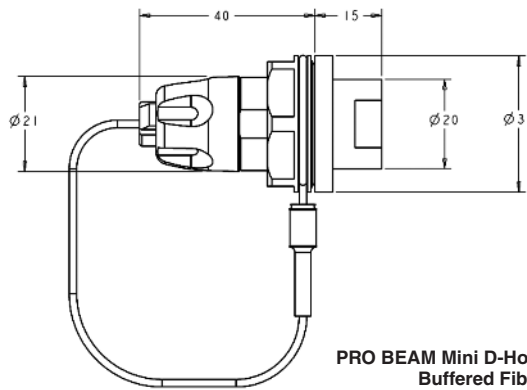

PRO BEAM Mini D-Hole Bulkhead Connector, Buffered Fiber, Low Profile

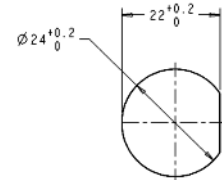

Recommended Panel Cutout

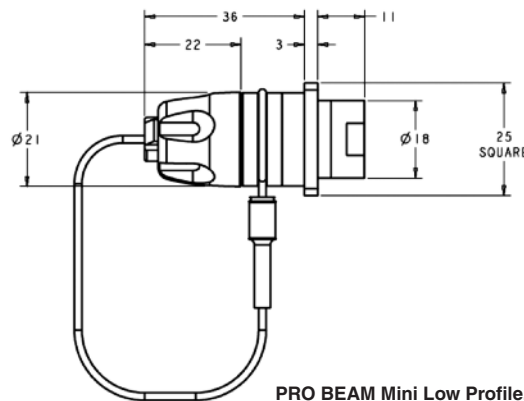

PRO BEAM Mini Low Profile, Square Flange Mount Bulkhead Connector

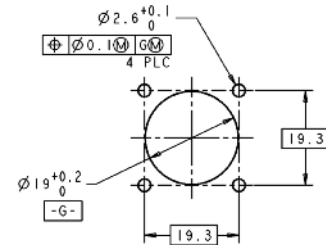

Recommended Panel Cutout

Expanded Beam Products (Continued)

PRO BEAM Mini Connectors

(Continued)

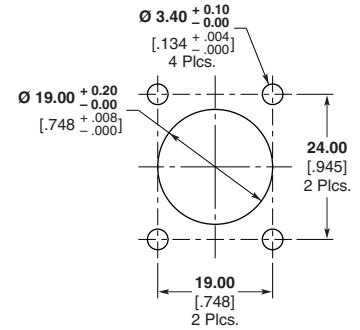
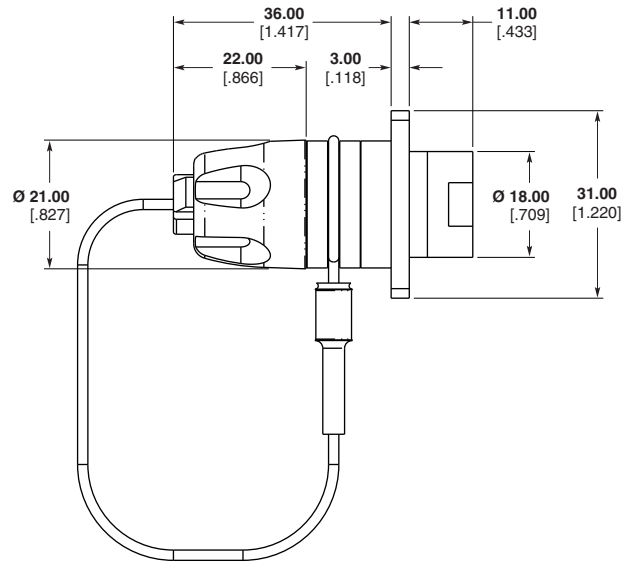

Recommended Panel Cutout

PRO BEAM Mini Low Profile,  
Alternate Square Flange Mount Bulkhead Connector

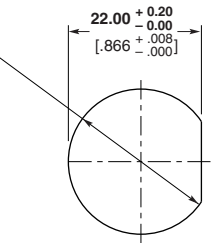
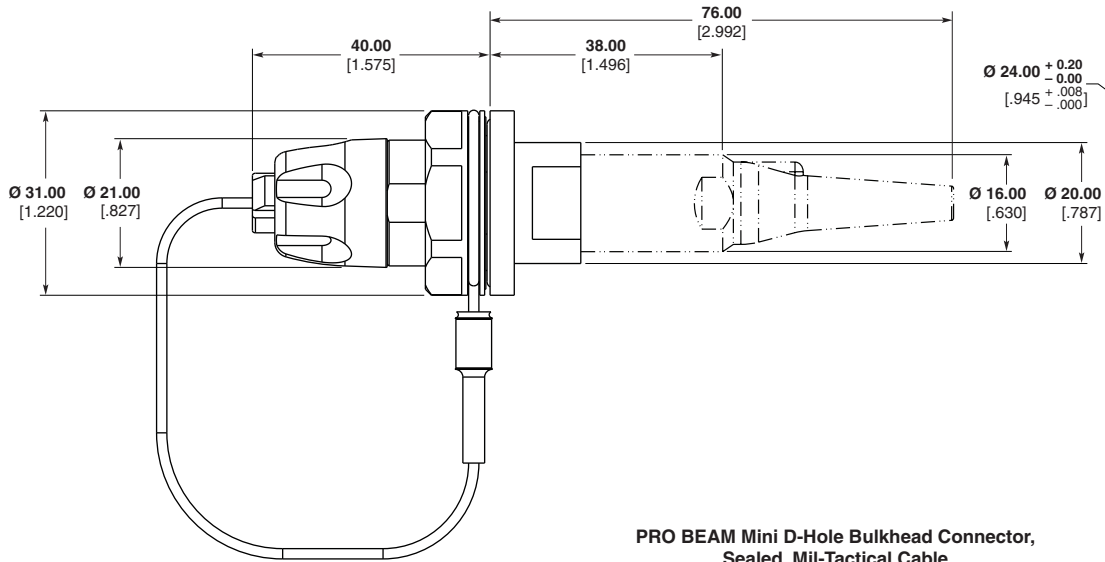

Recommended Panel Cutout

PRO BEAM Mini D-Hole Bulkhead Connector,  
Sealed, Mil-Tactical Cable

Expanded Beam Products (Continued)

**PRO BEAM Jr. Connectors**

**Performance Specifications**

**Optical, Multimode Version**

**Insertion Loss, Typical\***—  
0.7 dB @ 1300 nm and 850 nm dual wavelength

**Optical, Singlemode Version**

**Insertion Loss, Typical\***—  
0.8 dB @ 1310 nm or 1550 nm optimized wavelength

**Return Loss\*\***— > 34 dB @ 1310 nm or 1550 nm optimized wavelength

\*When tested with reference quality launch/receive cable assemblies

\*\*RL Tested Open Ended

**Mechanical**

**Vibration, Sinusoidal** —  
10 - 500 Hz, 3 directions;  
0.75 mm amplitude @ 10g acceleration

**Bump** — 4,000 Bumps, 6 directions @ 50g acceleration

**Free Fall** — 500 falls on concrete; Severity 1.2 m

**Coupling Endurance** —  
3,000 couplings

**Weight** —  
Plug — 123 grams, typical  
D-Hole bulkhead — 102 grams, typical

**Temperature**

**Operational Temperature** —  
-40°C/+85°C

**Storage Temperature** —  
-55°C/+85°C

**Temperature, Cyclic** —  
-55°C/+85°C

**Humidity (Damp Heat)** —95% RH

**Immersion**

**Water** — 15 m depth (plug) -  
15 m (Bulkhead)

**Material and Finish**

**Shell Alloy** — Aluminum; or nickel aluminum bronze (high saline environment)

**Plating (For Aluminum Shells Only)** — clear hard anodized; or green chromate conversion zinc or black zinc - nickel alloy (PRO BEAM Jr. Bulkheads only)

**Bulkhead Connector Panel Thicknesses**

**PRO BEAM Jr. Bulkhead Connector D-Hole** — 4 mm max.

**PRO BEAM Jr. Bulkhead Connector Square Flange** — 6 mm max.

Standard color black for Polymer Grip Rings, Cap and Boots. Alternate colors available upon request.

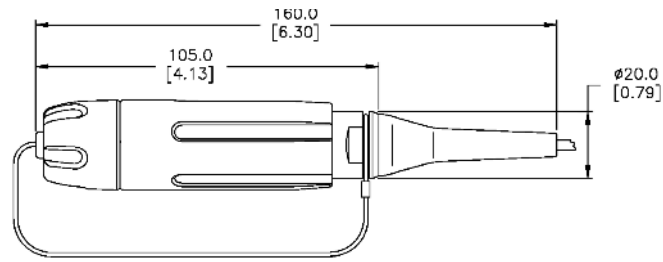

PRO BEAM Jr. Cable Connector, Plug

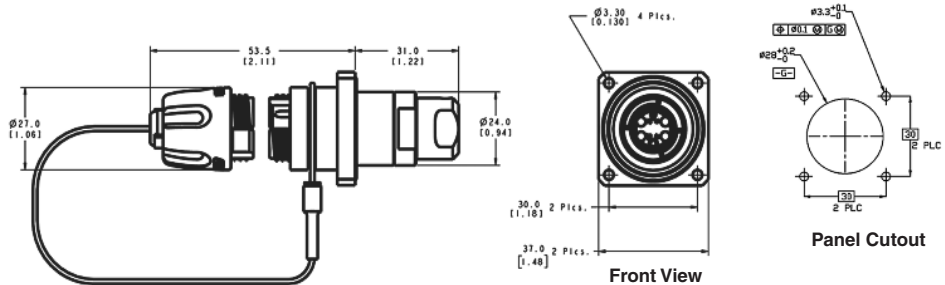

PRO BEAM Jr. Square Flange Mount Bulkhead Connector

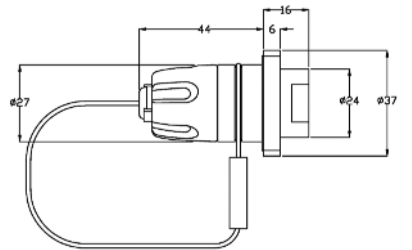

PRO BEAM Jr., Low Profile, Square Flange Mount Bulkhead Connector

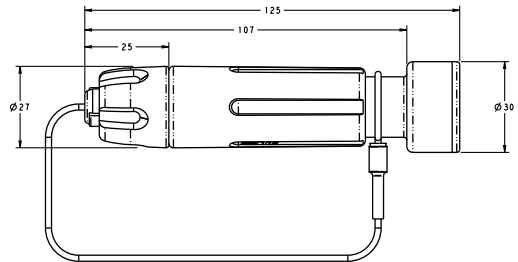

PRO BEAM Jr., Loopback Plug Connector

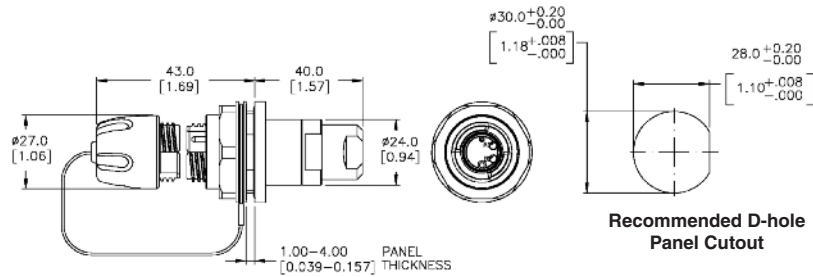

PRO BEAM Jr. D-Hole Standard Bulkhead Connector without Boot

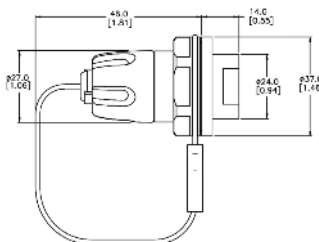

PRO BEAM Jr. Low Profile D-Hole Bulkhead Connector

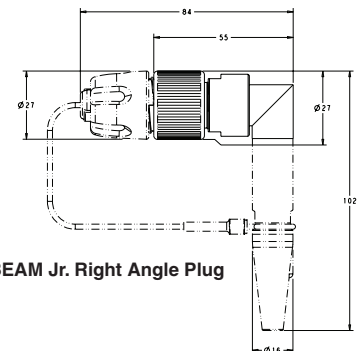

PRO BEAM Jr. Right Angle Plug



**Expanded Beam Products** (Continued)

**PRO BEAM Jr. Connectors**

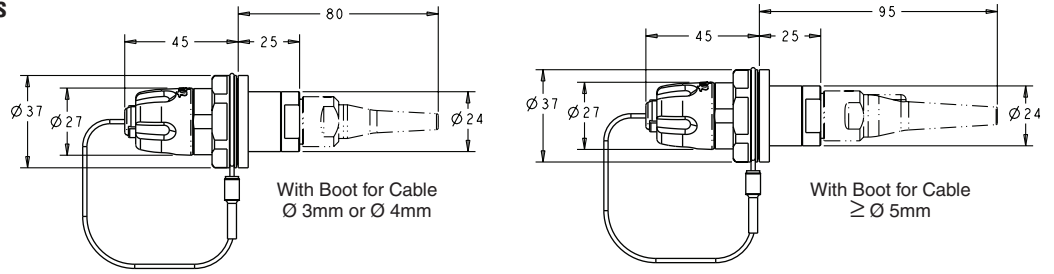

**PRO BEAM Jr. Standard Bulkhead Connector, with Boot**

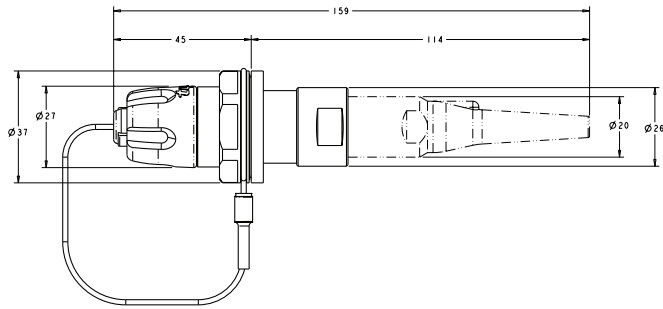

**PRO BEAM Jr. Sealed Bulkhead Connector**

**Expanded Beam Products** (Continued)

**PRO BEAM Jr. Connectors**  
(Continued)

**Connector Assembly**

- 1 Shell Kit
- 1 Insert Kit
- 1 Cable Adapter Kit\*
- X Ferrule Kits (X = No. of optical channels)

**Part Numbers listed are Shell alloy = aluminum Plating = hard anodized. Consult TE Connectivity for other plating/material options such as non-cadmium olive drab or RoHS-compliant black Zn/Ni.**

**PRO BEAM Jr. Connector Shell Kits**

Description	Alloy		
	Hard Anodized Aluminum Part Number	NiAlBz Part Number	Black Zinc Aluminum Part Number
PRO BEAM Jr. Plug w/EPDM rubber	1918937-1	1918937-2	—
PRO BEAM Jr. Right-Angle Plug Kit	1985915-1	—	—
PRO BEAM Jr. D-Hole Low Profile, Buffered Fiber Bulkhead	1693741-1	1693741-2	1754445-3
PRO BEAM Jr. D-Hole Low Profile, Simplex Cable Bulkhead	6828413-1	—	6828413-2
PRO BEAM Jr. D-Hole Standard Bulkhead	1918939-1	1918939-2	1918941-2
PRO BEAM Jr. D-Hole Sealed Bulkhead	1918940-1	1918940-2	1918940-4
PRO BEAM Jr. Square Flange Low Profile Buffered Fiber Bulkhead	1754439-1	1754439-2	1754447-3
PRO BEAM Jr. Square Flange Standard Bulkhead	1918943-1	1918943-2	—

**PRO BEAM Jr. Loopback Plug Assembly**

Description	Part Number
4 x 850 / 1300nm Multimode, 62.5/125 µm fiber	1516506-1
4 x 850 / 1300nm Multimode, OM3 50/125 µm fiber	1516506-2
4 x 1310nm Singlemode	1516506-3
4 x 1550nm Singlemode	1516506-4

**PRO BEAM Jr. Insert Kits**

Description	Part Number
2 x 850 / 1300nm Multimode	1515743-1
2 x 1310nm Singlemode	1515739-1
2 x 1550nm Singlemode	1516040-1
4 x 850 / 1300nm Multimode	1515747-1
4 x 1310nm Singlemode	1515740-1
4 x 1550nm Singlemode	1516041-1

**Ferrule Kits**

Fiber Hole Size	Mode	PRO BEAM	Part Number
125 m	SM	Jr.	1588908-2
126 m	SM	Jr.	1588908-1
126 m	MM	Jr.	1588700-1

**PRO BEAM Jr. Connector Plug & Sealed Bulkhead Cable Adapter Kits**

Cable Dia. Max.	Aluminum Plug Part Number	NiAlBz Plug Part Number	Aluminum Sealed Bulkhead Part Number	NiAlBz Sealed Bulkhead Part Number	Black Zn-Ni Part Number
3.2	1918931-1	1918931-9	1918932-1	1918932-9	2-1918932-5
3.6	1918931-2	1-1918931-0	1918932-2	1-1918932-0	2-1918932-6
4.2	1918931-3	1-1918931-1	1918932-3	1-1918932-1	2-1918932-7
5.2	1918931-4	1-1918931-2	1918932-4	1-1918932-2	2-1918932-8
5.7	1918931-5	1-1918931-3	1918932-5	1-1918932-3	2-1918932-9
6.2	1918931-6	1-1918931-4	1918932-6	1-1918932-4	3-1918932-0
6.7	1918931-7	1-1918931-5	1918932-7	1-1918932-5	3-1918932-1
7.5 (breakout cable only)	1918931-8	1-1918931-6	1918932-8	1-1918932-6	3-1918932-2

**Technical Documents**

**Product Specification**

108-2177 Design Objectives

**Application Specification**

114-13099

**Instruction Sheets**

408-10250 Grounding and Standard D-Hole Bulkhead

408-10222 Plug

408-10249 Sealed D-Hole Bulkhead

408-8834 Low Profile Square Flange Bulkhead

408-8840 Low Profile D-Hole Bulkhead

408-10251 Standard Square Flange Bulkhead

408-10018 Low Profile D-Hole Simplex Cable Bulkhead

408-10252 7.5 Cable Adapter

<http://www.te.com/documents>

**PRO BEAM Jr. Connector Standard Bulkhead Cable Adapter Kits\***

Cable Dia. Max.	Aluminum with Boot Part Number	NiAlBz with Boot Part Number	Black Zn-Ni Part Number	Aluminum without Boot Part Number	NiAlBz without Boot Part Number	Black Zn-Ni Part Number
3.2	1918933-1	1918933-9	2-1918933-5	1918934-1	1918934-8	2-1918934-2
4.1	1918933-2	1-1918933-0	2-1918933-6	1918934-2	1918934-9	2-1918934-3
5.1	1918933-3	1-1918933-1	2-1918933-7	1918934-3	1-1918934-0	2-1918934-4
5.5	1918933-4	1-1918933-2	2-1918933-8	1918934-4	1-1918934-1	2-1918934-5
6.0	1918933-5	1-1918933-3	2-1918933-9	1918934-5	1-1918934-2	2-1918934-6
4 x 3.00	1918933-8	1-1918933-6	3-1918933-2	1918934-7	1-1918934-4	2-1918934-8

\* Standard Cable Adapter. Not applicable for Low Profile.

**Note:** Part Numbers are RoHS compliant except: ♦ Indicates non-RoHS compliant.

**Expanded Beam Products** (Continued)

**PRO BEAM Jr. Connectors**

(Continued)

**Spare Parts & Tools**

**Technical Documents**

**Product Specifications**

408-8857 Curing Fixtures for PRO BEAM Jr. and Sr. Connectors

408-8828 Cleaning Procedure for EB C/A's

**Tooling Specifications**

408-8795 Crimp Tool with Die Set for PRO BEAM Jr. and Sr. Connectors

408-10022 Die Assembly for Mini and Jr. Circular Crimps

<http://www.te.com/documents>

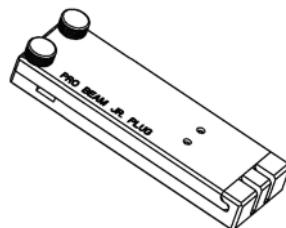

**Curing Fixtures**

Connector	Part Number
PRO BEAM Jr. Cable Plug (having cable with KEVLAR strength member fiber)	1693797-1
PRO BEAM Jr. Sealed D-Hole Bulkhead	
PRO BEAM Jr. Standard D-Hole and Square Flange Bulkhead	1693800-1
PRO BEAM Jr. Low Profile Buffered Fiber Bulkhead	1754122-1

Instruction Sheet 408-8857. Available at [www.te.com](http://www.te.com)

**Cable Crimp Components**

Description	Part Number
Crimp Sleeve (use with all PRO BEAM Jr. Connector Crimp Support sizes)	1918497-1
3.2 mm Crimp Support	1918498-1
4.2 mm Crimp Support	1918498-2
5.2 mm Crimp Support	1918498-3
5.7 mm Crimp Support	1918498-4
6.2 mm Crimp Support	1918498-5
6.7 mm Crimp Support	1918498-6
Square Crimp Support for (4) 3 mm Cables	1985319-1

**Ferrule Kits**

Fiber Hole Size	Mode	PRO BEAM	Part Number
125 μm	SM	Jr.	1588908-2
126 μm	SM	Jr.	1588908-1
126 μm	MM	Jr.	1588700-1

**Protective Caps**

Description	PRO BEAM	Part Number
Standard cap, for D-Hole Bulkhead	Jr.	1515868-1
Standard cap, for Flange Mount Bulkhead	Jr.	1515787-2
Standard cap, for connector plug	Jr.	1515867-1

**Termination Kit**

Part Number
1828650-1

KEVLAR is a trademark of E. I. du Pont de Nemours and Company.

**Note:** All part numbers are RoHS compliant.

Expanded Beam Products (Continued)

**PRO BEAM Sr. Connectors**

**Performance Specifications**

**Optical, Multimode Version**  
**Insertion Loss, Typical\***—  
 0.7 dB @ 1300 nm and 850 nm dual wavelength

**Optical, Singlemode Version**  
**Insertion Loss, Typical\***—  
 0.8 dB @ 1310 nm or 1550 nm optimized wavelength

**Return Loss\*\*** — > 34 dB  
 @ 1310 nm or 1550 nm optimized wavelength

\*When tested with reference quality launch/receive cable assemblies

\*\*RL Tested Open Ended

**Mechanical**

**Vibration, Sinusoidal** —  
 10 - 500 Hz, 3 directions;  
 0.75 mm amplitude @ 10g acceleration

**Bump** — 4,000 Bumps, 6 directions,  
 @ 50g acceleration

**Free Fall** — 500 falls on concrete;  
 Severity 1.2 m

**Coupling Endurance** —  
 3,000 couplings

**Weight** —  
 Plug — 290 grams, typical  
 Chassis bulkhead — 150 grams, typical

**Temperature**

**Operational Temperature** —  
 -40°C/+85°C

**Storage Temperature** — -55°C/+85°C

**Temperature, Cyclic** — -55°C/+85°C

**Humidity (Damp Heat)** — 95% RH

**Immersion**

**Water** — 5 m depth (plug),  
 2 m (Bulkhead)

**Material and Finish**

**Shell Alloy** — Aluminum; or nickel aluminum bronze (high saline environment)

**Plating (For Aluminum Shells Only)** — clear hard anodized or black zinc - nickel alloy (PRO BEAM Sr. bulkheads only)

**Bulkhead Connector Panel Thicknesses**

**PRO BEAM Sr. D-Hole Connector** — 6.5 mm max.

**PRO BEAM Sr. Square Flange Connector** — 8.5 mm max.

**Technical Documents**

**Product Specifications**  
 408-8799 Plug  
 408-8800 D-Hole Bulkhead  
 408-8877 Square Flange Bulkhead

**Application Specification**

114-13122  
<http://www.te.com/documents>

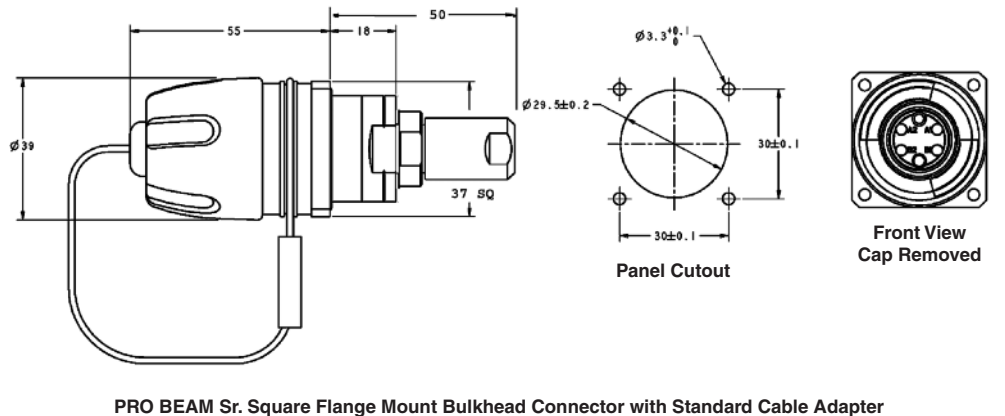
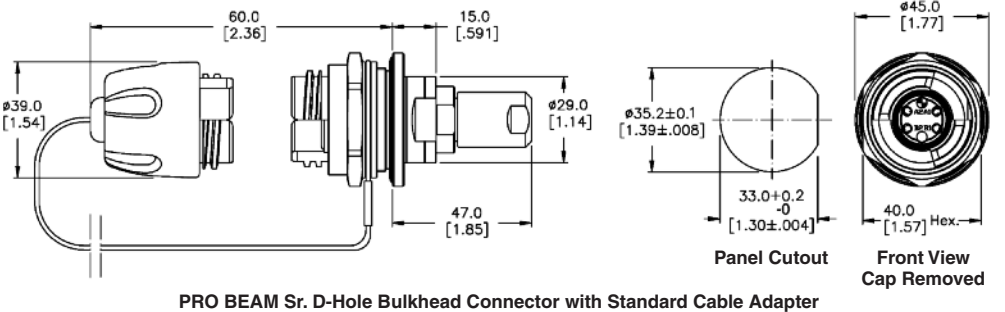
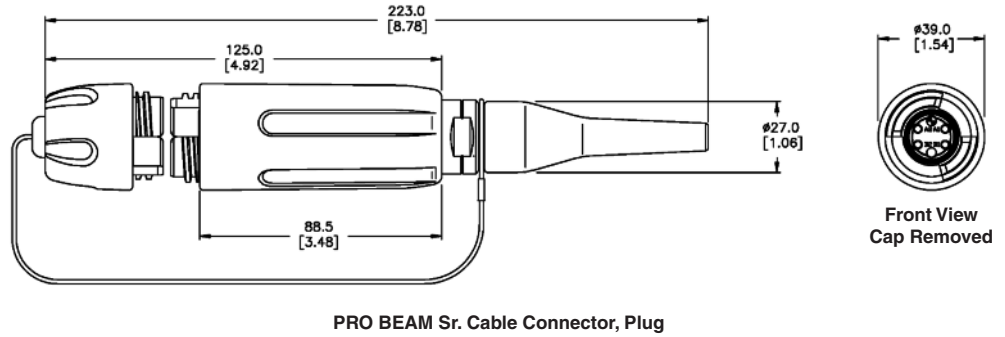

Standard color black for Polymer Grip Rings, Cap and Boots. Alternate colors available upon request.

**Expanded Beam Products** (Continued)

**PRO BEAM Sr. Connectors**

(Continued)

**Connector Assembly**

- 1 Shell Kit
- 1 Insert Kit
- 1 Cable Adapter Kit\*
- X Ferrule Kits (X = No. of optical channels)

\*Not applicable for Low Profile

**Part numbers listed are Shell alloy = aluminum Plating = hard anodized. Consult TE Connectivity for other plating/material options such as NiAlBz for Naval applications, or other plating options such as RoHS-compliant black Zn-Ni.**



**Technical Documents**

**Product Specifications**

408-8857 Curing Fixtures for PRO BEAM Jr. and Sr. Connectors

408-8828 Cleaning Procedure for EB C/A's

**Tooling Specifications**

408-8795 Crimp Tool with Die Set for PRO BEAM Jr. and Sr. Connectors

<http://www.te.com/documents>

PRO BEAM Sr. Connector Shell Kits	Alloy	
	Aluminum Part Number	NiAlBz Part Number
PRO BEAM Sr. Plug w/EPDM rubber	1754842-1	1754842-2
PRO BEAM Sr. D-Hole Standard Bulkhead	1754843-1	1754843-2
PRO BEAM Sr. Square Flange Standard Bulkhead	1754844-1	1754844-2

PRO BEAM Sr. Insert Kits	Part Number
2 x 850 / 1300 nm Multimode	1693001-1
2 x 1310 nm Singlemode	1515734-2
4 x 850 / 1300 nm Multimode	1693001-2
4 x 1310 nm Singlemode	1515735-1
8 x 850/1300 nm Multimode	1516256-1
8 x 1310 nm Singlemode	1516258-1
8 x 1550 nm Singlemode	1516258-2

**PRO BEAM Sr. Ferrule Kits**

Fiber Hole Size	Mode	Insert Application	Part Number
125 µm	SM	2 & 4 Channel	1515941-1
126 µm	SM	2 & 4 Channel	1515941-2
126 µm	MM	2 & 4 Channel	1588801-1
125 µm	SM	8 Channel	1985635-1
126 µm	SM	8 Channel	1985635-2
126 µm	MM	8 Channel	1985107-1

**PRO BEAM Sr. Connector Plug Adapter Kits**

Cable Dia. (Max.)	Alloy	
	Aluminum Part Number	NiAlBz Part Number
5.10 .201	1515940-1	1515940-2
5.65 .222	1515940-3	1515940-4
6.20 .244	1515940-5	1515940-6
6.70 .264	1515940-7	1515940-8

**PRO BEAM Sr. Connector Standard Bulkhead Cable Adapter Kits**

Cable Dia. (Max.)	Style	Alloy	
		Aluminum Part Number	NiAlBz Part Number
5.20 .205	Standard Cable Adapter	1516229-3	1516229-7
5.70 .224	Standard Cable Adapter	1516229-2	1516229-6
Buffered Fiber	Low Profile Adapter	1516229-4	1516229-8
6.70 .264	Standard Cable Adapter	1-1516229-3	1-1516229-4
4 x 3 mm	Standard Cable Adapter	1516229-1	1-1516229-5

**Note:** All part numbers are RoHS compliant.

Expanded Beam Products (Continued)

**38999 Style EB for Harsh Environments**

**Product Facts**

- Available in shell size 11, housed on D38999 Series III style shells for harness applications
- Multiple options available for backshells. Consult your local TE Connectivity Sales Representative
- Shell polarizations A through E available upon request

**Standard Material and Finish**

**Shell Alloy** — Aluminum  
**Plating** — Nickel or green chromated zinc or RoHS-compliant black chromated zinc-nickel alloy

\*Refer to customer drawing for dash number designation

For part number details and plating options, contact your local TE Connectivity Sales Representative.

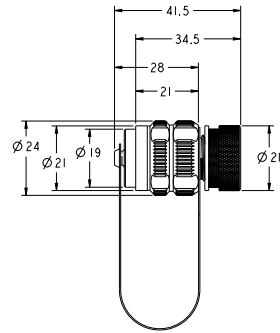

**38999 Plug Shell Kit for mini EB**

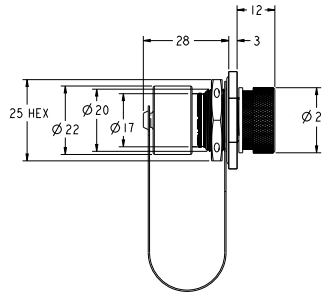

**38999 Jam-Nut Receptacle Shell Kit for mini EB**

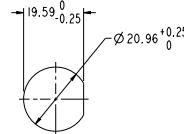

**38999 Shell Kit Wall Mount Receptacle for mini EB**

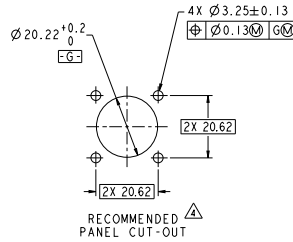
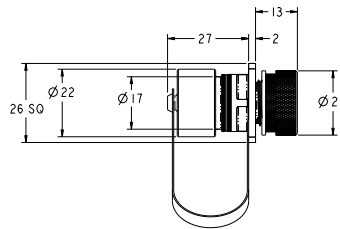

**38999 D-Hole Bulkhead Shell Kit**

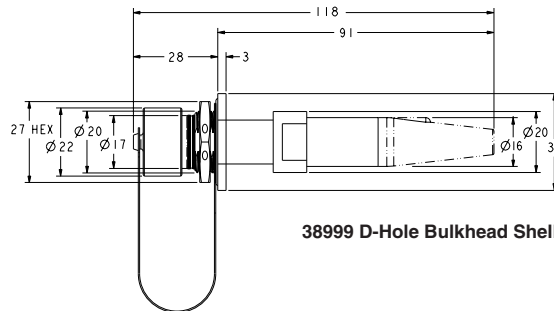

**38999 D-Hole Bulkhead Shell Kit**

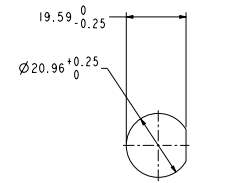

**RECOMMENDED PANEL CUT-OUT**

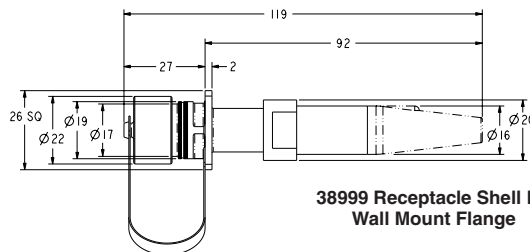

**38999 Receptacle Shell Kit Wall Mount Flange**

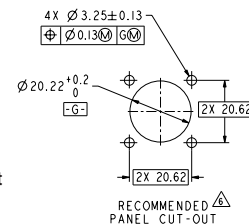

**RECOMMENDED PANEL CUT-OUT**

**ASSEMBLY CAPABILITIES**  
 TE Connectivity has extensive Rugged Optic Harness capabilities. Please consult your local TE Sales representative for assistance.

**Note:** All part numbers are RoHS compliant.



Expanded Beam Products (Continued)

38999-style EB for Harsh Environments (Continued)

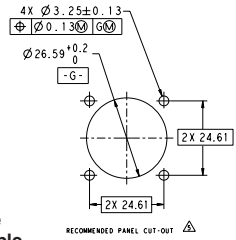
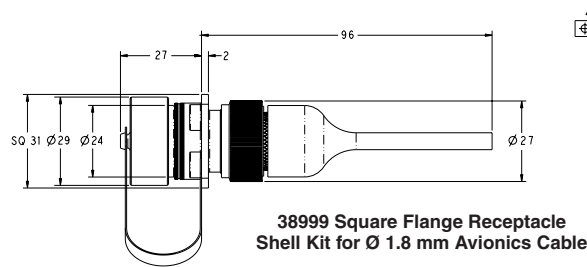
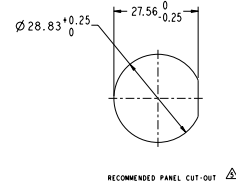
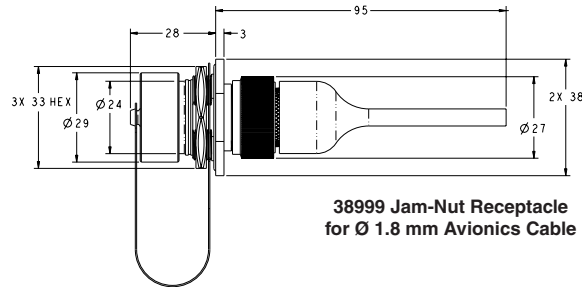
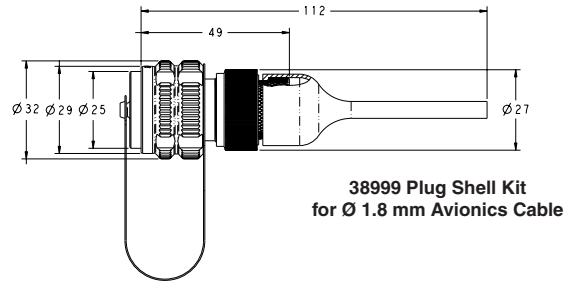
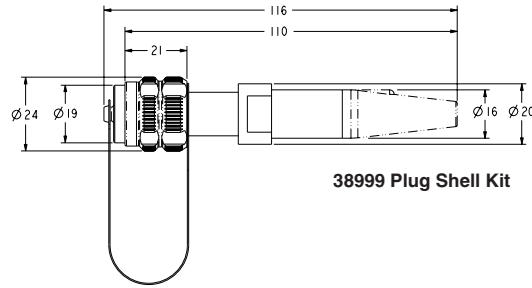

**Expanded Beam Products** (Continued)

**38999-style EB for Harsh Environments** (Continued)

**Size 11 Shield Kit**

Use with:	Mini EB 38999 Connector Shell Kits (N-Key)								
	Ø1.8 mm Max Avionics Cable			MIL-Tactical Distribution Cable			Buffered Fiber Only		
	Electroless Ni Plate	OD Zn	Black Zn-Ni	Electroless Ni Plate	OD Zn	Black Zn-Ni	Electroless Ni Plate	OD Zn	Black Zn-Ni
Plug:	6754518-1	1754518-7 ♦	6754518-7	1985021-1	1985021-7 ♦	—	1918883-1	1918883-7 ♦	1-1918883-3
Jam-Nut Receptacle:	6754519-1	1754519-7 ♦	6754519-7	2064163-1	2064163-7 ♦	—	1918884-1	1918884-7 ♦	1-1918884-3
Flange-Mount Receptacle:	6754520-1	1754520-7 ♦	6754520-7	2064166-1	2064166-7 ♦	—	1918885-1	1918885-7 ♦	1-1918885-3

\* Contact TE Connectivity for availability.

**Size 15 Shield Kit**

Use with:	2.2 mm Ø Max Avionics Cable		End Nut Backshell for Non-Jacketed Cable	
	Electroless Nickel Plate	Black Zinc Nickel	Electroless Nickel Plate	Black Zinc Nickel
Plug:	1516342-1	1516342-7	1516338-1	1516338-7
Jam-Nut Receptacle:	1516343-1	1516343-7	1516339-1	1516339-7
Flange-Mount Receptacle:	1516344-1	1516344-7	1516340-1	1516340-7

**Cable Adapter Kits For 38999 Mini EB Mil-Tactical**

Cable Diameter	Part Number
5.1 mm	1516228-1
5.6 mm	1516228-2
6.2 mm	1516228-3

**Insert Kits**

Description	Part Number
Mini 2 x 850 / 1300 nm Dual Multimode	1374759-4
Mini 2 x 1310 nm Singlemode	1588129-2
Mini 2 x 1550 nm Singlemode	1588128-2
Mini 4 x 850 / 1300 nm Dual Multimode	1374759-2
Mini 4 x 1310 nm Singlemode	1588129-3
Mini 4 x 1550 nm Singlemode	1588128-3
8 x 850/1300 nm Multimode	1516256-1
8 x 1310 nm Singlemode	1516258-1
8 x 1550 nm Singlemode	1516258-2

**Ferrule Kits**

Fiber Hole Size	Mode	Insert Type	Part Number
125 µm	SM	Mini	1754700-1
126 µm	SM	Mini	1754700-2
126 µm	MM	Mini	1754699-1
125 µm	SM	8 Channel	1985635-1
126 µm	SM	8 Channel	1985635-2
126 µm	MM	8 Channel	1985107-1

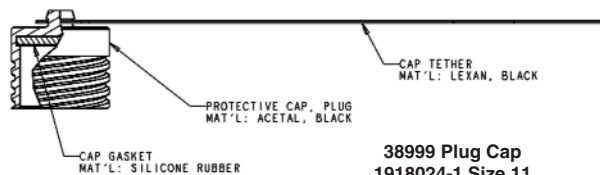

**38999 Plug Cap**  
1918024-1 Size 11  
1918024-2 Size 15

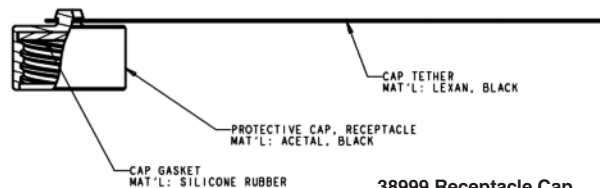

**38999 Receptacle Cap**  
1918025-1 Size 11 = Jam Nut Receptacle  
1918025-2 Size 11 = Square Flange Receptacle  
1918025-3 Size 15 = Jam Nut Receptacle  
1918025-4 Size 15 = Square Flange Receptacle



**Note:** Part Numbers are RoHS compliant except: ♦ Indicates non-RoHS compliant.

**Expanded Beam Products** (Continued)

**EB termini**

**Product Facts**

- Durable non-contacting interface assures ease of use/cleaning
- Termini designed to replace existing M29504/4 and /5 physical contact termini that fits the Size 16 AWG cavity of a D38999 III connector
- MM and SM termini designs

EB termini are combination of inserts (containing the lens) and EB termini (for terminating the fiber).

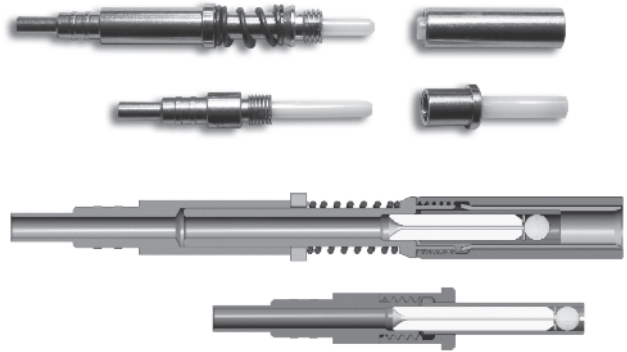

**Cable Assemblies and Accessories**

**Product Facts**

- Ruggedized cable assemblies custom tailored for field use in harsh environments
- Heavy-duty light-weight cable reel organizes and protects connectors and cable for easy pay-out and safe storage
- Options for 500 meter reels include special backpack harnesses, a separate reel stand, or a combination reel and reel stand

**Featured Cable Assemblies**



**TFOCA to PRO BEAM Jr. Plug Cable Assembly**  
1828536-1 ♦

**LP D-Hole Bulkhead to 4 ST 62.5/125 on 1.8 mm cable**  
6828454-1 ♦

**Plug to Plug (100 meters)**  
6754475-2

**Typical Reels and Reel Stands for Field-Deployable Cable Assemblies**



1918930-1



Tactical Reel/Drum Options

**PRO BEAM Jr. Kits**  
**PRO BEAM Jr. Termination Kit**  
1828650-1  
**Cleaning Kit**  
1828335-2

**Cable Reels**

**Reel Capacity (Random Lay)**

Cable Diameter	Notes/Description	Flange Diameter	Part Number
<b>5.8 mm</b>			
186 M	Reel & Reel Stand Combination Reel can be detached from stand without tools	310 mm	1918930-1
247 M	Reel*	310 mm	1754515-1
462 M	Reel*	370 mm	1754515-2
816 M	Reel*	460 mm	1754515-3
1052 M	Reel*	510 mm	1754515-4

\* See Accessories options below

TFOCA-II is a trademark of Amphenol Fiber Systems International.

**Note:** Part Numbers are RoHS compliant except: ♦ Indicates non-RoHS compliant.

**Cable Assemblies and Accessories** (Continued)

**ASSEMBLY CAPABILITIES**  
 TE Connectivity has extensive Rugged Optic Harness capabilities. Please consult your local TE Sales representative for assistance.



Backpack with Reel



Reel with Stand "Static Frame"



Backpack Harness

**Accessories**

Description	Reel Diameter	Part Number
Backpack	370 mm Dia. Reel	1754516-1*
Backpack	460 mm Dia. Reel	1754516-2*
Backpack	510 mm Dia. Reel	1754516-3*
Static Frame	500 mm Dia. Max	1754517-1*
Static Frame	700 mm Dia. Max	1754517-2*

\* Reel must be ordered separately.

**Note:** For lower cost alternative options. Please contact your local TE Connectivity Sales Representative or TE Product Information Center at 1-800-522-6752.

**Tactical Optical Cable**

**Non-Metallic Tactical Field Deployable Fiber Optic Cable**

**Product Facts**

- All terrain field deployable cable, up to 4 fibers, singlemode or multimode
- Developed for deployment under the most demanding conditions
- Tight buffered fibers are protected by Aramid yarns and a tough ruggedized polyurethane sheath
- Tested in accordance with MIL-PRF-85045
- Flexible, water resistant, high crush resistant, and lightweight,
- Designs available to be resilient against radiation exposure

**Technical Data**

**Mil-Standard Distribution Cable — 2 Fiber Singlemode**

**Attenuation** —  $\leq 0.5$  dB/km @ 1310 nm /  $\leq 0.5$  dB/km @ 1550 nm  
**Diameter** — 5.8 mm  
**Weight** — 25 kg/km  
**Minimum Bending Radius** — 29 mm  
**Crush Resistance** — 2000 N/cm  
**Operating Temperature** — -55° C to +85° C

**Mil-Standard Distribution Cable — 4 Fiber Singlemode**

**Attenuation** —  $\leq 0.5$  dB/km @ 1310 nm /  $\leq 0.5$  dB/km @ 1550 nm  
**Diameter** — 5.8 mm  
**Weight** — 27 kg/km  
**Minimum Bending Radius** — 28 mm  
**Crush Resistance** — 2000 N/cm  
**Operating Temperature** — -55° C to +85° C

**Mil-Standard Distribution Cable — 2 Fiber Multimode**

**Fiber Type** — 50  $\mu$ m/125  $\mu$ m and 62.5/125  
**Attenuation** —  $\leq 3.5$  dB/km @ 850 nm /  $\leq 1.0$  dB/km @ 1300 (62.5/125);  $\leq 3.5$  dB/km @ 850 nm /  $\leq 1.5$  dB/km @ 1300 (50/125)

**Mil-Standard Distribution Cable — 4 Fiber Multimode**

**Fiber Type** — 50  $\mu$ m/125  $\mu$ m and 62.5/125  
**Attenuation** —  $\leq 3.5$  dB/km @ 850 nm /  $\leq 1.0$  dB/km @ 1300 (62.5/125);  $\leq 3.5$  dB/km @ 850 nm /  $\leq 1.5$  dB/km @ 1300 (80/125)

Other fibers (i.e. Polyimide, Silicon buffer, Carbon coated, radiation hardened, etc.) are available upon request.

Contact TE Connectivity or your local TE Sales Representative for part numbers, pricing, and availability.

**ARMOR-LIGHT Tactical Field Deployable Fiber Optic Cable for Extreme Environments (Metallic for Rodent Proof)**



**4-Color Optical Fiber Cable Specification for Armored Cable for Ruggedized Applications Construction:**

- 4-color coded fibers
- Fiber types 50/125/250  $\mu$ m, 62.5/125/250  $\mu$ m and 9/125/250  $\mu$ m
- Stainless steel gel filled tube
- Stainless steel wire
- Jacket — Nylon, black

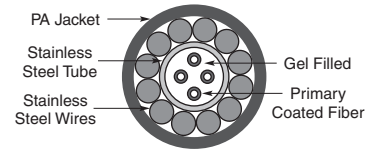

Fiber Type	Part Number	Outside Dia. (mm)	Weight kg/km	Max. Attenuation dB/km				Bandwidth MHz-km	
				850 nm	1300 nm	1310 nm	1550 nm	850 nm	1300 nm
62.5/125	1588957-1	3.8	24	3.5	1.0	X	X	160	500
50/125	1588957-2	3.8	24	2.7	0.9	X	X	400	1200
SM	1588957-4	3.8	24	X	X	0.40	0.25	X	X

**Notes:** 35 mm recommended bend radius.  
3.1 kN breaking strength.

**2-Color Optical Fiber Cable Specification for Armored Cable for Ruggedized Applications Construction:**

- 2-color coded fibers
- Fiber types 50/125/250  $\mu$ m, 62.5/125/250  $\mu$ m and 9/125/250  $\mu$ m
- Stainless steel gel filled tube
- Stainless steel wire
- Jacket — Nylon, black

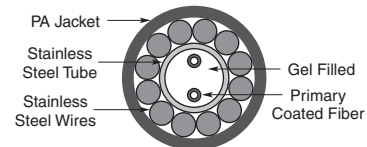

Fiber Type	Part Number	Outside Dia. (mm)	Weight kg/km	Max. Attenuation dB/km				Bandwidth MHz-km	
				850 nm	1300 nm	1310 nm	1550 nm	850 nm	1300 nm
62.5/125	1693808-1	3.8	24	3.5	1.0	X	X	160	500
50/125	1693808-2	3.8	24	2.7	0.9	X	X	400	1200
SM	1693808-4	3.8	24	X	X	0.40	0.25	X	X

**Notes:** 35 mm recommended bend radius.  
3.1 kN breaking strength.

**Note:** All part numbers are RoHS compliant.



**Commercial Fiber Optic Mechanical Splicing Kit**

**Light Crimp Splice**

Part Number: 1985368-1

**Product Facts**

- Terminates 250 micron coated, 900 micron tight-buffered fibers and 2.0 mm jacketed cable
- Attenuation (typical): ≤0.1dB
- Return Loss (at ambient; 18° to 28° C): ≥20 dB multimode  
≥35 dB single-mode
- Operating Temperature: -25° to 70° C
- Storage Temperature: -40° to 85° C
- Tensile retention:  
250 micron coated: 2.0 N  
900 micron buffered: 3.0 N  
Jacketed: 50.0 N



Part Number: 151626-1



Part Number: 1516516-1

The KITCO 0831-8238 Kit Provides a low cost, highly reliable, solution for the repair of Tactical Fiber Optic Cables featuring the TE Connectivity Mechanical Splice. The Kit contains all of the tools and materials required to make (3) three four channel cable repairs, including the JPS-400 Splice Protection Sleeve. An Ideal solution in a tactical environment when system reliability is essential, not an option!

**The TFOCA Military/ Commercial Fiber Optic Mechanical Splicing Kit contains the following items:**

- 2 JPS-400 Splice Protection Sleeves
- 12 Mechanical Splices
- Light Crimp Splice
- Precision Cleaver
- Crimp Tool with Crimp Die
- Splice Holder with Strip Template
- Cleaning Materials
- Tool Roll with all Required Tools
- Support for LC/SC Light Crimp Connectors
- Lightweight, rugged Case

**JPS Splice Enclosure**

Part Number: 1516516-1

The JPS 400 Splice Enclosure is designed to protect TFOCA cable that has been repaired with any mechanical splice or fusion splicer. Designed & evaluated by the United States Marine Corps, this product works in all field applications, even in severe or harsh battlefield environments. Simple to install and easy to re-enter, yet flexible enough to conform to the diameter of a reel

when re-wound. The JPS 400 is ideal for both TFOCA AND TFOCA Second Generation applications.

There are two high-grade brass retention assemblies that use both the jacket and the Aramid yarn found in TFOCA cable to provide strain relief & secure the fiber inside the waterproof housing. A waterproof compression gasket prevents water and other contaminants from entering the housing.

**JPS 400 Mechanical Properties & Performance Specifications:**

- High-grade formulated polyamide conduit & threaded adapters
- Self-extinguishing, low smoke, halogen & cadmium free
- Temperature Range: -50C to +105C continuous, 150C short term
- Chemical resistance to fuels, mineral oils, fats, and alkalies

- Specifically designed for external application in traction industry
- Size: 15" x .630" (ID) x .932" (OD)
- Re-enterable & Re-usable
- Conforms to TFOCA reel sizes
- Cable Size Range: .196"-.394"
- Pull Strength (Load Test): 250 lbs
- Waterproof

Ser Number	RFP Specification	Compliance to RFP specification YES/NO	In case of non-compliance deviation from RFP to be specified in unambiguous terms
(a)	Splicing Capability	For up to 1-4 splices SM & MM	Y
(b)	Water Proofing Standard	IP64 class for the hard cover case	Y
(c)	Tube Protection class	Better then IP67 (24 h @ 5000 mm)	IP68
(d)	Time taken to repair a cable	Fast & reliable cable repair within 10 min - 30 min (1F , 4F)	Y
(e)	Maximum Attenuation for Mechanical splices	Typical value < 0.2 db @ 1300 nm	Y
(f)	Should be able to splice Armored/ Ruggedized cable (as offered by the vender)	Yes	Y
(g)	Reusable components	100% reusable components (except mechanical splice protector)	Y
(h)	Temperature range	Operating Temp: -10°C - 50°C Non-Operating Temp: -40°C 71°C	
(j)	Weight	< 4.2 kg	Do not have kit. TE has kit in India.
(k)	Dimensions (max)	410x33x202mm	Do not have kit. TE has kit in India.
(l)	Tensile load of cable after repair	No Change	250 lbs

**Optical Test Set for Fiber Optic Cables**

**Designed for harsh environments**

**Product Facts**

- Especially designed to support the installation of optical links in the field
- Able to test both cable drums and entire links
- Powered by batteries with high autonomy
- Suitable for diagnostics and construction teams
- Easy to use, ergonomic, rugged design
- Suitable for cable length up to 10 km
- Supports up to 4 fibers per cable with various types of connectors



**Diagnostic Features**

**Power Meter**

The optical power from any source can easily be measured with the power meter function.

**Optical Source**

A continuous optical signal is generated and transmitted with selectable output power.

**Drum Test / Cable Test**

Test of an entire cable drum with automatic good/bad indication. The test of an entire cable is realized with a 2nd KPG-opt or a loop connector.

**Test Frames (optional)**

The KPG-opt can generate specific test frames as used in optical networks and LOS systems.

**Optical Tester**

Description	Part Number
850 nm 38999 III Size 11 Optical Test Kit	1918016-1
850/1300 nm PRO BEAM Jr. Optical Test Kit	1918016-2
1310 nm PRO BEAM Jr. Optical Test Kit	1985006-1

For additional wavelength testers, contact your local TE Connectivity Sales Representative.

Protective Case
1918082-1

**Note:** All part numbers are RoHS compliant.

Fiber Optic Accessories

Hand Held Visual Fault Locator (VFL)

Product Facts

- 650 nm (visible) Class 2 1.0 mW max Diode Laser
- Continuous and flashing (2-3 Hz pulsed) modes
- Rugged rubber shell and body design modeled after a popular military connector
- Lanyard attached dust cover
- Standard 2.5 mm adapter for SC, ST, and FC connectors
- Optional 1.25 mm adapter for LC and MU connectors.
- Unique design allows adapter to permanently reside on VFL so it is not misplaced allowing user to choose 1.25 mm or 2.5 mm
- Uses 1 “AA” style battery for >30 hours of continuous use
- Soft-sided belt case for convenience and storage



The TE Connectivity Hand Held Visual Fault Locator (VFL) is a rugged and affordable solution for identifying breaks and bending in optical fibers and cabling. Its powerful, red (650 nm) laser provides the ability to locate damaged, broken, or tightly bent fibers that cause undesirable attenuation in your system.

The jacket of the cable will glow red at the location of the fault. The FLASH button

allows the user to toggle between continuous or pulsed mode. The compact, rugged, and balanced design is based upon a popular harsh environment fiber optic connector. The single “AA” style battery is good for >30 hours of continuous use and the soft-sided protective case with belt loop provides a convenient and protective means of storage.

Applications

Affordable VFL Solution for:

- Identifying breaks, bends, and other damage in optical fibers
- Tracing fiber paths
- Identifying termination errors
- Continuity testing

Product Dimensions

- Length — 18.5 cm [7.283 in]
- Width — 2.2 cm [0.866 in]
- Thickness — 2.2 cm [0.866 in]
- Weight (w/battery) — 150 g [0.33 lb]

Description	Part Number
Hand Held Visual Fault Locator	1828352-1
1.25 mm Adapter for Hand Held VFL	1828353-1
Includes Part Numbers 1828352-1 and 1828353-1	1828352-2

Expanded Beam Avionics-Related Standards and Specifications

**ARINC 600, 664, 763 and 801**

**ARINC 664 — Aircraft Data Network**

TE Connectivity's ARINC Connectors with Mini Expanded Beam inserts will meet/exceed all 100 Base-FX Ethernet LAN applications

**ARINC 763 — Avionics Network Server System —**

TE's ARINC 600 Connectors are designed to meet/exceed 100 Base-FX Ethernet LAN applications.

**Network Server Unit (NSU)** — can use ARINC 600 Size 1 connector with up to 8 Expanded Beam fiber optic channels (two Mini Expanded Beam inserts in cavity C)

**Server Interface Unit (SIU)** — can use ARINC 600 Size 3 connector with up to 16 Expanded Beam fiber optic channels (four Mini Expanded Beam inserts in cavity F)

**Integrated Network Server Unit (INSU)** — can use ARINC 600 Size 3 connector with up to 16 Expanded Beam fiber optic channels (four Mini Expanded Beam inserts in cavity F)

**ARINC 801 — Fiber Optics Working Group**

TE provides a single reference point for Flight Level Optics that are multi-sourced.

Typical Assemblies for In-Flight Network Applications

*ARINC EB Connector-to-ARINC EB Connector Cable Assembly*

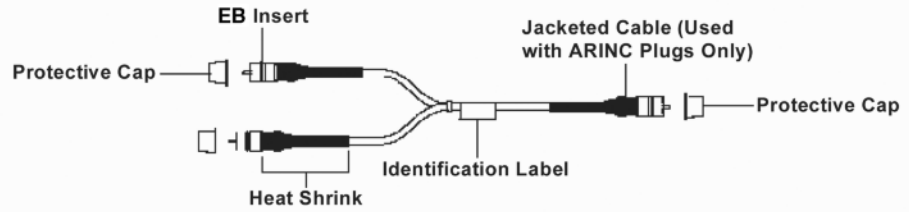

*ARINC EB Connector-to-Circular Metal Connector Cable Assembly*

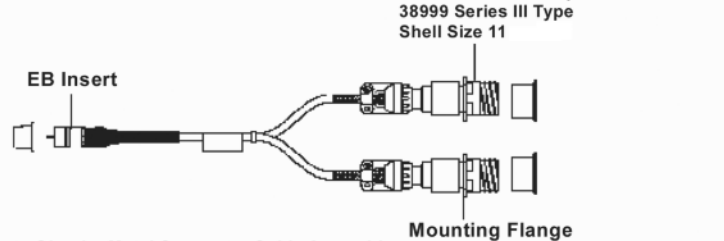

*Circular Metal Connector-to-Circular Metal Connector Cable Assembly*

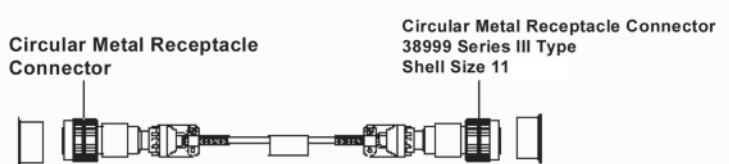

*ARINC EB Connector-to-ST-Style Cable Assembly*

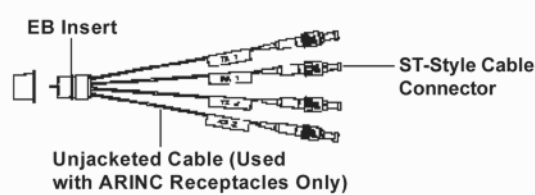

Typical Assemblies



**ASSEMBLY CAPABILITIES**  
TE Connectivity has extensive Rugged Optic Harness capabilities. Please consult your local TE Sales representative for assistance.

**ARINC 600 and 404**

**Product Facts**

- For Mini Expanded Beam Inserts
- For use in 100 base-FX Ethernet LAN applications per ARINC 664 and ARINC 763
- Insert holders designed to ARINC 600, Supplement 13 or to specific customer needs for Mini Expanded Beam inserts
- Drop-In Insert Holders utilize Standard ARINC 600 Retainers
  - Hard Stop on Plug Side
  - Spring-Loaded Stop on Receptacle Side
  - Captive Hardware
- Facial Sealing — Optional
  - Bonded to Receptacle Block Mating Face
  - Raised Collar Seal around Optics Insert compresses against Chamfer on Plug Block Mating Face

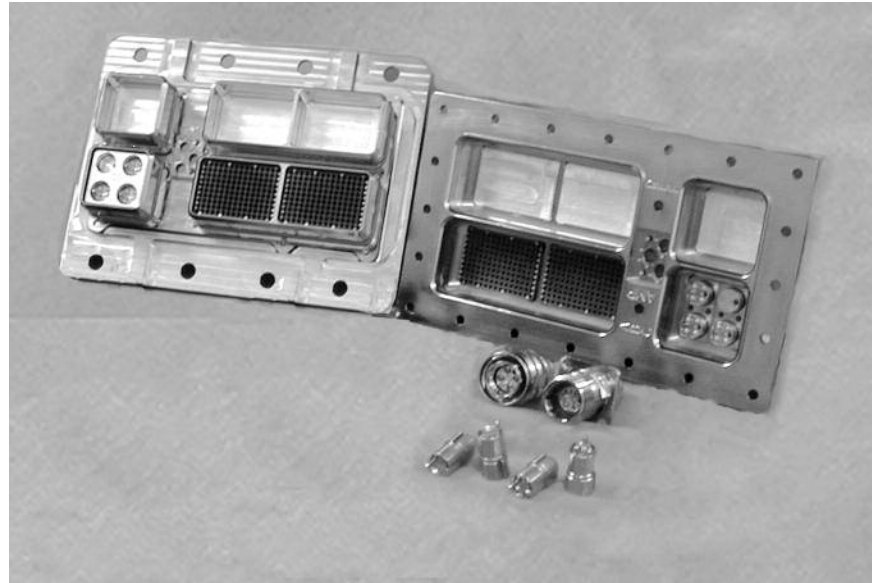

**ARINC 600 Insert Holders for Mini-Expanded Beam Contacts**

**Size 1 Power Cavities**

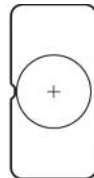

ARINC 600, 1 Position  
1MP

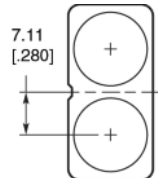

ARINC 600, 2 Position  
2MP

**Size 1 Signal Cavities**

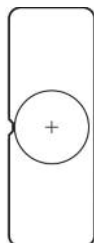

ARINC 600, 1 Position  
1MS

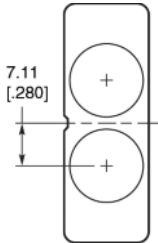

ARINC 600, 2 Position  
2MS

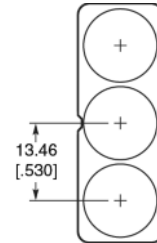

ARINC 600, 3 Position  
3MS

**ASSEMBLY CAPABILITIES**  
TE Connectivity has extensive Rugged Optic Harness capabilities. Please consult your local TE Sales representative for assistance.

See next page for Size 2 / 3 Power and Signal Cavities



ARINC 600 and 404 (Continued)

Size 2 / 3  
Power and Signal Cavities

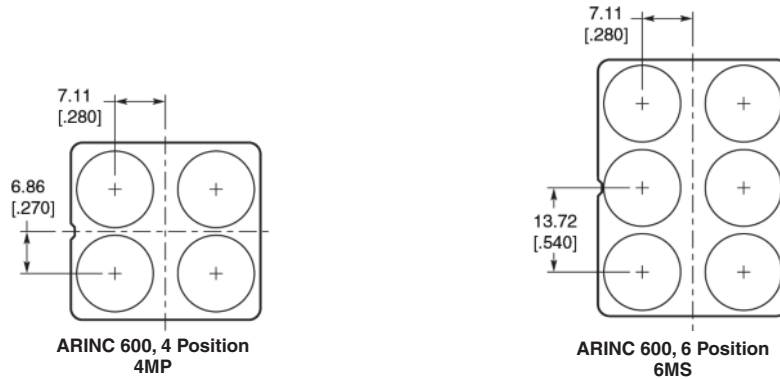

Rack and Panel Mini Insert Kits

Description	Part Number
2 x 850 / 1300 nm Dual Multimode	1374759-3
2 x 1310 nm Singlemode	1588839-3
2 x 1550 nm Singlemode	1754622-3
4 x 850 / 1300 nm Dual Multimode	1374759-1
4 x 1310 nm Singlemode	1588839-1
4 x 1550 nm Singlemode	1754622-4

Ferrule Kits

Fiber Hole Size	Mode	PRO BEAM Connector	Part Number
125 μm	SM	Mini	1754700-1
126 μm	SM	Mini	1754700-2
126 μm	MM	Mini	1754699-1

ARINC 600 Insert Holders  
for Mini-Expanded Beam  
Contacts

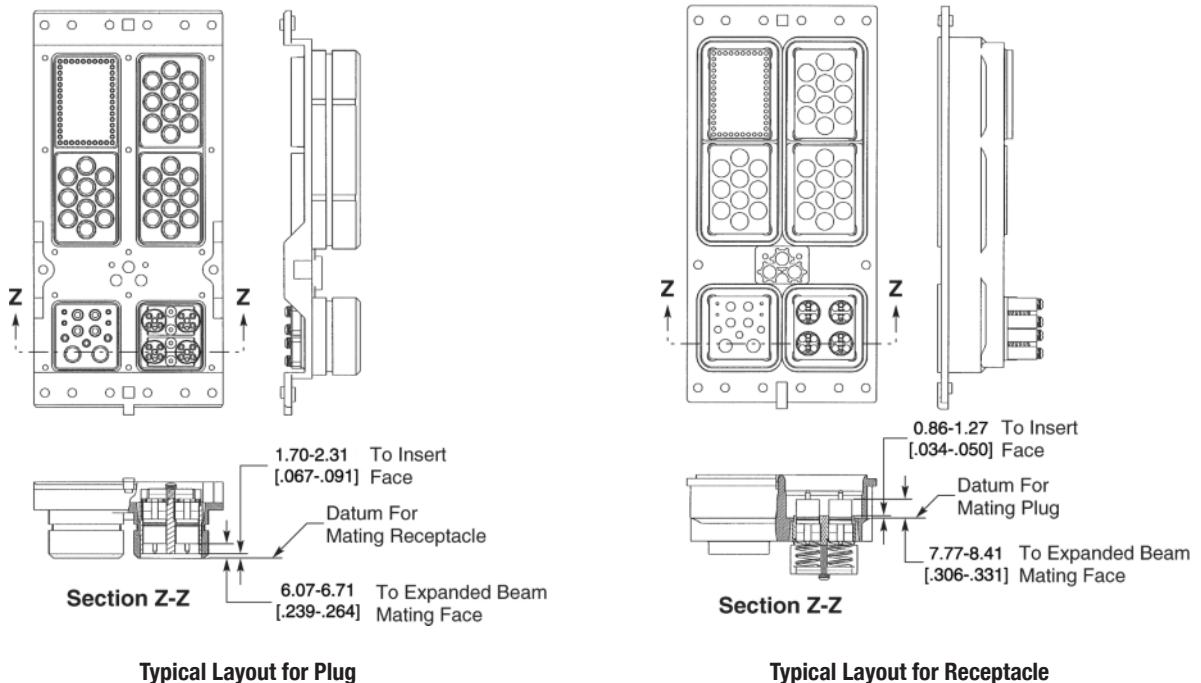



ARINC 600 and 404 (Continued)

M2 Mini-Expanded Beam  
Insert Holders for GPRB

Holder Kit, Pin (Spring-Loaded), Mini-Expanded Beam  
Key A – GPRB-1445162-1  
Key B – GPRB-2000189-1

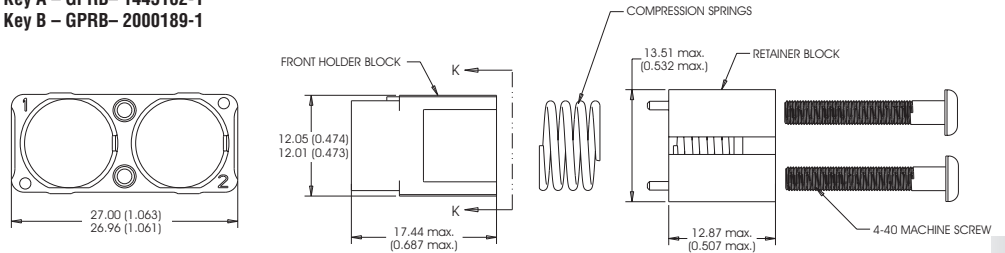

SECTION K - K

MINI-E BEAM HOLDER KIT

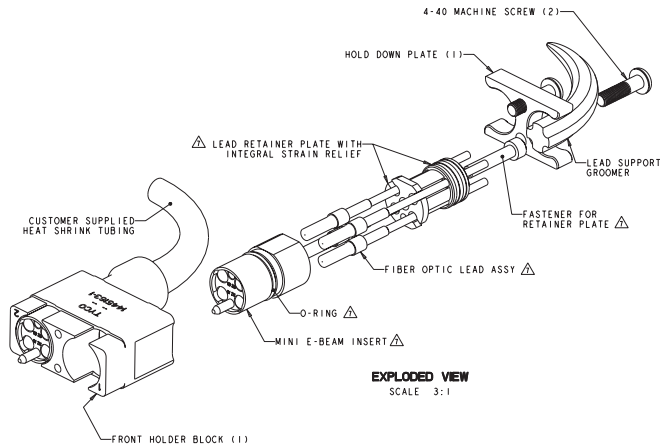

EXPLODED VIEW  
SCALE 3:1

Holder Kit, Socket (Fixed), Mini-Expanded Beam,  
Key A – GPRB-1445163-1  
Key B – GPRB-2000190-1

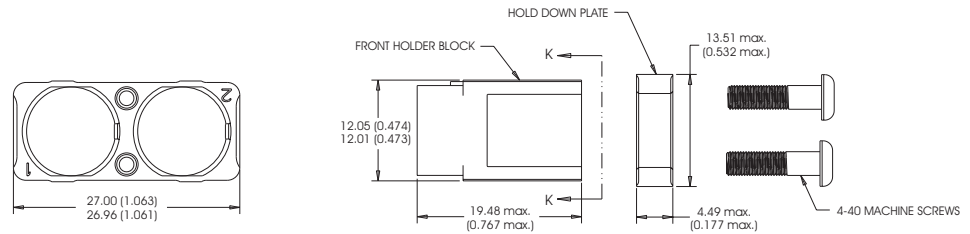

SECTION K - K

MINI-E BEAM HOLDER KIT

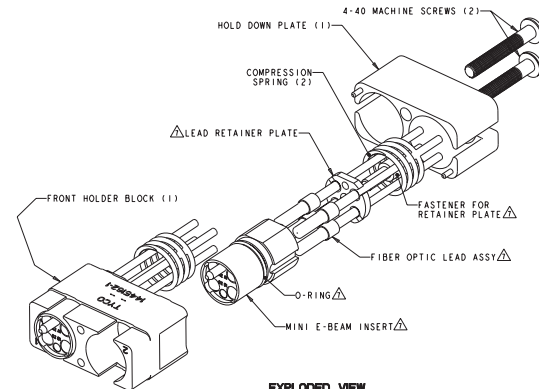

EXPLODED VIEW  
SCALE 3:1

**ARINC 600 and 404** (Continued)

**Insert Kits for GPRB Holders**

**Rack and Panel Mini Insert Kits**

Description	Part Number
2 x 850 / 1300 nm Dual Multimode	1374759-3
2 x 1310 nm Singlemode	1588839-3
2 x 1550 nm Singlemode	1754622-3
4 x 850 / 1300 nm Dual Multimode	1374759-1
4 x 1310 nm Singlemode	1588839-1
4 x 1550 nm Singlemode	1754622-4

**Ferrule Kits**

Fiber Hole Size	Mode	PRO BEAM Connector	Part Number
125 $\mu$ m	SM	Mini	1754700-1
126 $\mu$ m	SM	Mini	1754700-2
126 $\mu$ m	MM	Mini	1754699-1

**Comparative on Expanded Beam Inserts**

**Comparative on Expanded Beam Inserts' weight and Insertion Forces when applied to an ARINC housing**

- ARINC 600 connector mated pair size 2 = 440 grams (without copper contacts)
- ARINC style Mini and Junior size Expanded Beam inserts = 5 pounds insertion force each when applied to the Rack and Panel ARINC Connector inserts
- Signal Cavity Optical Holder insert (i.e.: holds up to six mini inserts with four fiber ball lenses each or up to 24 fibers each insert set) = @ 30 grams
- Power Cavity Optical Holder insert (i.e.: holds up to four mini inserts with four fiber ball lenses each or up to 16 fibers each insert set) = @ 20 grams
- Insert mated pair PRO BEAM Jr. Connector insert set = @ 41.79 grams
- Insert mated pair Connector insert set = @ 16.17 grams
- Fiber = single fiber  $\leq$  4 kg / km
- Fiber = four fiber jacketed with a support member  $\leq$  24 kg / km
- Static spring force per mated Expanded Beam insert pair = 5 lbs.

Physical Contact & Technology

ARINC 801 Optical Termini

Product Facts

- Optical termini for use with GPR, ARINC 600, circular MIL-DTL-38999 connectors.
- Industry Standard 1.25 mm ceramic ferrule
- Compatible with 1.5-2.2 mm Tight jacket and loose tube cable construction:
  - MT - Tight jacket cable
  - ML - Loose tube cable
- SM / MM versions

Materials

- Housings** — Nickel Plated Copper
- Ferrule** — Zirconia
- Spring** — Stainless Steel
- Crimp Sleeve** — Nickel Plated Copper
- Protective Cover** — Silicone

Optical Performance

Singlemode, 1310 nm/1550 nm (UPC):

- Attenuation, Mean — 0.15dB
- Return Loss — > 50dB

Multimode, 850 nm/1310 nm:

- Attenuation, Mean — 0.10dB
- Return Loss — > 20dB

ARINC 801 Optical Termini

one common terminus for all types of connectors

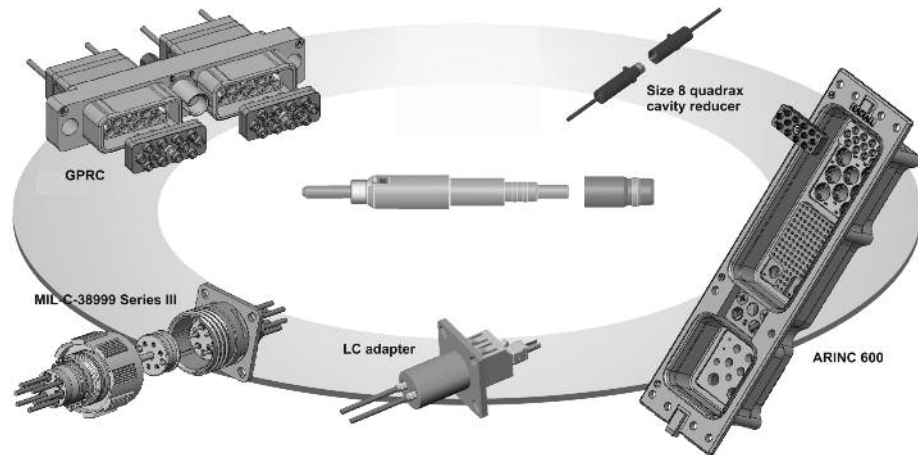

3

Ruggedized Fiber Optic Connectors

Mechanical / Environmental Performance

Test Description	Standard	ARINC 801 Optical Termini in GPR A & B Connector	ARINC 801 Optical Termini in 38999 Connector	ARINC 801 Optical Termini in ARINC 600 Connector
Thermal Shock	SAE-AS-13441 met 1003.1	-55C /+100C	-55C /+100C	-55C /+100C
Temperature Life	TIA/EIA 455-20A	500h @ +100C	500h @ +100C	500h @ +100C
Vibration	TIA/EIA 455-11	8h/axis 3.8g <sup>2</sup> /Hz 43 G rms	8h/axis 3.8g <sup>2</sup> /Hz 43 G rms	8h/axis 0.2g <sup>2</sup> /Hz 16.4 G rms
Shock	TIA/EIA 455-14A	300 G - 3ms	300 G - 3ms	50G - 11ms
Mate/Unmate (GPR/ARINC 600)	SAE-AS-13441 met 2016	100 Cycles	N/A	100 Cycles
Mate/Unmate (38999)	TIA/EIA 455-21A	N/A	500 Cycles	N/A
Maint. Aging	SAE-AS-13441 met 2002-1	10 Cycles	10 Cycles	10 Cycles
Salt Spray	SAE-AS-13441 met 1001.1 cond C	96 hr	500 hr	48 hr
Cable Ret. (1.8 mm)	SAE-AS-13441 met 2009-1	68N	68N	68N
Humidity (GPR/38999)	TIA/EIA 455-5 met B7A	10 cycles / 24h 90% RH -25C/+65C	10 cycles / 24h 90% RH -25C/+65C	N/A
Humidity (ARINC 600)	TIA/EIA 455-5 met B	N/A	N/A	10 cycles / 24h 90% RH -25C/+65C
Altitude Imm.	TIA/EIA 455-15	10,000 ft (69.6kPa)	10,000 ft (69.6kPa)	10,000 ft (69.6kPa)



## Physical Contact & Technology (Continued)

### ARINC 801 Optical Termini (Continued)

There are three types of ARINC 801 Optical Termini available dependent upon cable structure.

TE Connectivity has multiple connector types/families available for the ARINC 801 Optical Termini System.

These are:

- **General Purpose Rectangular Connectors**
  - F5 & F12 Inserts
- **MIL-DTL-38999 connectors**
  - 13-04, 15-06, 21-16
- **ARINC 600**
  - F12 combinations and F36
- **Quadrax Cavity Reducers**
- **Motherboard & Daughtercard Solutions**

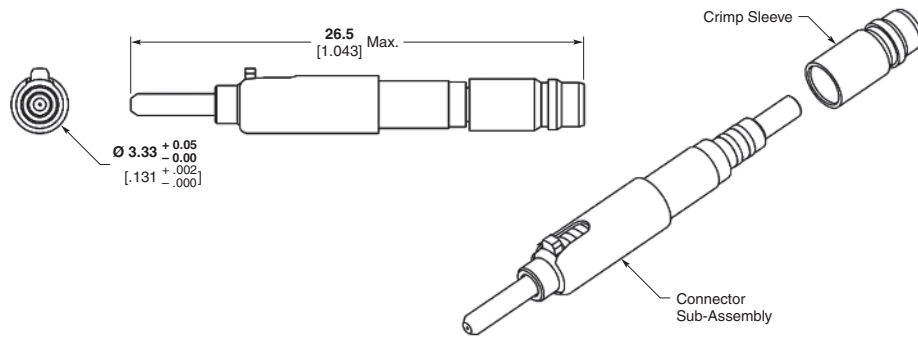

### ARINC 801 Optical Termini Part Numbers

Cable Dia.	Cable Structure ML (loose & tight) MT (ultra tight)	S/M Fiber 125.3 µm PC/UPC	S/M Fiber 125.3 µm APC	M/M Fiber 128 µm PC
0.9mm Buffer	—	*	*	*
1.5 - 2.2 mm	ML	1918614-1	1918616-1	1828199-1
1.5 - 2.2 mm	MT	1918615-1	1918617-1	1828200-1

Consult your local TE Sales Representative for additional options.

\* Contact TE for availability.

Accessories	Part Number
Dust Cap	1985335-1
100 Pc Bulk Pack	1985335-2

### ARINC 801 Cavity Reducers

Size 8 Quadrax	Part Number	ARINC 801 Cavity Reducer
Pin Quadrax adapter for ARINC 801 Optical Termini in Quadrax FR type cavity	1757727-1	Quadrax cavity reducer (FR/FR) for receptacle shell
Pin Quadrax adapter for ARINC 801 Optical Termini in Quadrax RR type cavity	1757710-1	Quadrax cavity reducer (RR/RR) for receptacle shell
Socket Quadrax adapter for ARINC 801 Optical Termini in Quadrax RR type cavity	1757711-1	Quadrax cavity reducer (RR/RR) for plug shell

**Connector Options:**  
For part numbers, details, and / or additional connector types and arrangements, contact your local TE Sales Representative.



### Cable Structure

	Loose Structure	Tight Structure	Ultra Tight Structure
Movement between fiber & 900 µm buffer	Yes	No	No
Movement between 900 µm & cable jacket	Yes	Yes	No

### Adapters

Type	Version	Alignment Sleeve	Part Number	Dim. (page 3-32)
ARINC 801 Optical Termini to ARINC 801 Optical Termini	Simplex Bulkhead Feedthrough Type	Ceramic Zirconia	1828996-1	Fig. 1
ARINC 801 Optical Termini to ARINC 801 Optical Termini	Simplex Straight	Ceramic Zirconia	1828997-1	Fig. 2
ARINC 801 Optical Termini to LC	Simplex LC Panel Cutout	Ceramic Zirconia	1828979-1	Fig. 3
ARINC 801 Optical Termini to LC	Duplex LC Panel Cutout	Ceramic Zirconia	1828980-1	Fig. 4
ARINC 801 Optical Termini to LC	Duplex MIL-DTL-38999 Panel Cutout	Ceramic Zirconia	1828995-1	Fig. 5

### Tools

Description/Function	Part Number
Metal Extraction Tool (M81 969/1-03)	91066-3
Plastic Extraction Tool (M81 969/1403)	M81969/14-03
Daniels Right Angle Insertion Tool	DAK83-16*
Daniels Right Angle Removal Tool	DRK83-16*

\* Contact Daniels Manufacturing Corporation

**Note:** All part numbers are RoHS compliant.

Physical Contact & Technology (Continued)

**F12 ARINC 801  
Insert Assemblies**



**Product Facts**

- ARINC 801 approved
- Optical termini for use with GPR, ARINC 600, circular MIL-DTL-38999 connectors
- Industry Standard 1.25 mm ceramic ferrule
- Compatible with 1.5-2.2 mm tight jacket and loose tube cable construction:
  - MT - Tight jacket cable
  - ML – Loose tube cable
- Singlemode (SM) and Multimode (MM) versions
- ARINC 801 Optical Termini part numbers:
  - 1828199-1 MM/ML Version
  - 1828200-1 MM/MT Version
  - 1918614-1 SM/ML Version
  - 1918616-1 SM/ML Version-APC
  - 1918615-1 SM/MT Version
  - 1918617-1 SM/MT Version-APC

**Materials:**

- Housings** – Nickel Plated Copper
- Ferrule** – Zirconia
- Spring** – Stainless Steel
- Crimp Sleeve** – Nickel Plated Copper
- Protective Cover** – Silicone

**Optical Performance**

- Singlemode**, 1310 nm/1550 nm (UPC)
  - Attenuation, Mean** – 0.15dB
  - Return Loss** - >50dB
- Multimode**, 850 nm, 1310 nm
  - Attenuation, Mean** – 0.10dB
  - Return Loss** - >20dB

**Assembly Capabilities**

TE Connectivity has extensive Rugged Optic Harness capabilities. Please consult your local TE Sales Representative for assistance.

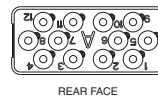
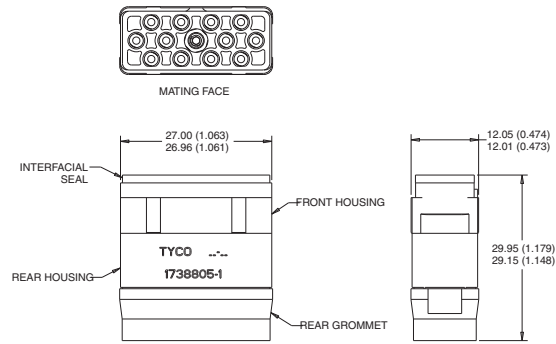

REAR FACE  
Insert Assembly, without Sleeve Holder, Environmental, F12  
Key A 1738805-1  
Key B 1738806-1

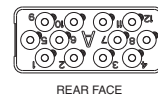
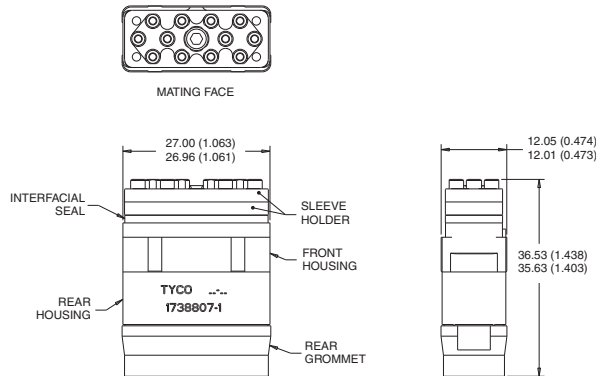

REAR FACE  
Insert Assembly, with Sleeve Holder, Environmental, F12, Key A GPRB  
Key A 1738807-1  
Key B 1738808-1

**ARINC 801 Inserts**

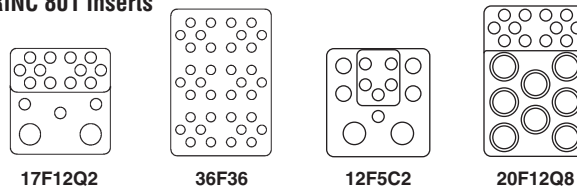

ARINC 801 Inserts and Cavity Reducers accept ARINC 801 Optical Termini.

**Note:** All part numbers are RoHS compliant.

Physical Contact & Technology (Continued)

ARINC 801 Optical Termini Adapter Dimensions

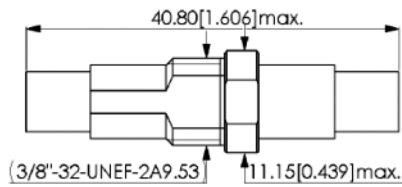

Terminus to Terminus Bulkhead Feedthrough  
Figure 1

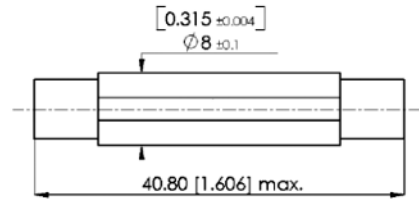

Terminus to Terminus Straight  
Figure 2

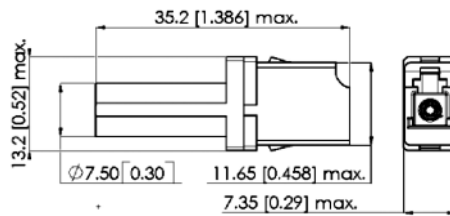

Terminus to LC Simplex  
Figure 3

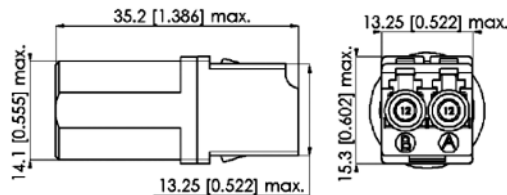
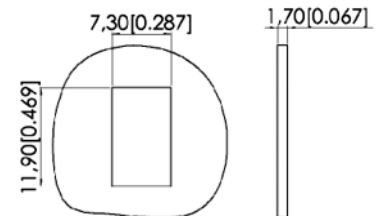

Terminus to LC Duplex, LC Panel  
Figure 4

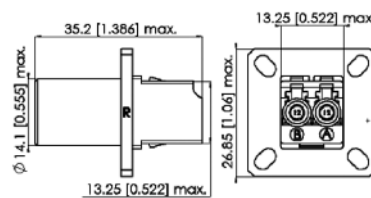
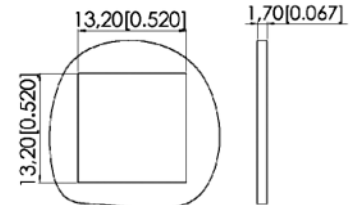

Terminus to LC Duplex, MIL-DTL-38999 Panel Cutout  
Figure 5

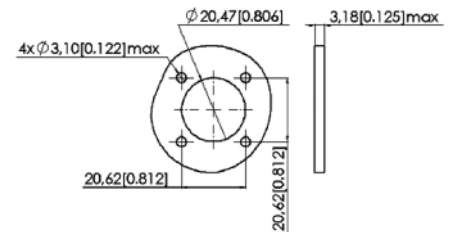

**Physical Contact & Technology** (Continued)

Most of the tools included in the Termination Kit are commonly used in the fiberoptic industry (strippers, cutting pliers and all accessories for fiber and cable preparation). The items in the table below are specially made for the ARINC 801 Optical Termini System. Their use is highly recommended to achieve mechanical and optical performances.

**ARINC 801 Optical Termini Termination Kit**  
Part Number 1828644-X



Qty -2	Qty -1	Description	Part Number	Item #
1	1	Label, Termination Kit	1918887-1	28
1	1	Insertion and Extraction Tool	91066-3	27
2	2	1.25 mm Swab	1828355-1	26
1	1	LC Polishing Bushing	1754074-1	25
1	1	Polishing Plate	501197-1	24
1	1	Polishing Pad	501523-1	23
10	10	0.3 µm Polishing Film	228433-5	22
5	5	Fine Diamond Polishing Film	503887-1	21
10	10	5 µm Polishing Film	228433-8	20
15	15	9 µm Polishing Film	1374484-1	19
1	1	Cleave Tool	504064-1	18
1	—	Curing Oven Block	1918510-1	17
1	—	Curing oven	502130-1	16
1	1	Resin injector tips	1918509-2	15
1	1	Resin injector	1918509-1	14
5	5	Epoxy, 353ND	504035-1	13
10	10	Alcohol Fiber Wipe	501857-2	12
1	1	Inner Ferrule Shaping Tool	1918511-1	11
1	1	Hexagonal key	19840-5	10
1	1	Fiber Stripping tool (125 µm)	1754708-1	9
1	1	Handtool	58532-1	8
1	1	Die-set, ARINC 801 Optical Termini	1828889-1	7
1	1	KEVLAR Shears	1278637-1	6
1	1	Cable Jacket Strip Tool	1278531-1	5
1	—	1.25 mm Microscope Adapter	1754765-1	4
1	—	200x Microscope	1754767-1	3
1	—	Carrying case, Weekender	1918881-1	2
—	1	Carrying case, Attache	1918834-1	1

The following tools are necessary for product termination but are not included in the kit: Alcohol, canned air, and clean cloth. Other accessories available include ruler, tweezers, cleaning tip, roller adhesive tape, moss cable support and permanent ink markers.

**ARINC 801 Optical Termini Service Tool Kit (Inspection, testing & cleaning)**  
Part Number 1828335-1

**ARINC 801 Optical Termini Service Tool Kit (Cleaning only)**  
Part Number 1828335-2

**ARINC 801 Optical Termini Service Tool Kit (Testing only)**  
Part Number 1828335-3

**ARINC 801 Optical Termini Service Tool Kit (Hand Held Digital Probe Kit)**  
Part Number 1828335-4

**Tool Kit Contents**

Item #	Comp Part Number	Description	-1	-2	-3	-4
1	1278540-1	Soft Carry Bag	1	—	—	—
2	1754767-1	200x Microscope	1	—	—	—
3	1754765-1	LC Microscope adapter	1	—	—	—
4	6374613-5	LC - SC 50/125 cable assembly	2	—	—	—
5	6374615-5	LC - SC 62.5/125 cable assembly	2	—	—	—
6	1918808-1	1.25 mm swab	2	2	—	—
7	1918810-1	OPTIPOP C Card Cleaner	2	5	—	—
8	1828349-1	Optical Loss Test Set	1	—	1	—
9	1828350-1	OLTS 1.25 mm detector cap	1	—	1	—
10	1828352-1	Visual Fault Locator	1	—	1	—
11	1828353-1	VFL 1.25 mm Adapter	1	—	1	—
12	1828465-1	Label, Service Kit	1	—	1	—
13	1918222-1	Inspection, Hand Held Digital Probe Kit	—	—	—	1
14	1918223-1	1.25 mm Adapter, Digital Probe	—	—	—	1

-1 inspection, cleaning & testing  
-2 cleaning  
-3 testing  
-4 Hand Held Digital Probe Kit

**Note:** All part numbers are RoHS compliant.

KEVLAR is a trademark of E.I. du Pont de Nemours and Company.  
OPTIPOP is a trademark of NTT Advanced Technology Corporation.



**Ruggedized Fiber Optic Products** (Continued)

**MIL-T-29504 Style Optical Connector Range**

**Product Facts**

- Manufactured to meet the requirements of MIL-T-29504/4 and 5
- Proven in both rotary and fixed-wing aerospace applications
- Sprung loaded socket contacts ensure consistent pressure and performance levels

The range of MIL-T style optical contacts is designed specifically for use with the MIL-DTL-38999 Series III connectors within the standard size 16 cavity.



**Optical Inserts for EN4165 and ARINC 809**

**Product Facts**

- Interchangeable modular inserts
- Easy use insertion / extraction tool
- Easy access to optical contacts for cleaning maintenance
- Compliments DMC-M multiway modular connector range

TE has designed a comprehensive range of Fiber optic inserts to further enhance our EN4165 connector range. To date the modular inserts can accommodate MC5, MC6 ribbon, Arinc 801 and EN4531 optical contacts.



**Fiber Optical Insert for DMC-M**

**Product Facts**

- Light weight composite
- Colour coded
- Modularity
- Screw coupling

An optical insert is available for the popular DMC-M connector which enables six standard MC5 contact to be incorporated into a single insert package or 12 way MC6 or 4 way Arinc 801 contacts.



**RSC-v**

**Product Facts**

- Suitable for singlemode applications
- Good return loss measurements
- Tuneable PC variant for optimum performance

APC version of the ever popular RSC connector range. The RSC-V is available with either an angled polish (APC) or a tuneable physical contact (PC) variant.



### Ruggedized Circular Connectors

#### 38999

##### Product Facts

- **100% Scoop Proof**
- **High strength Aluminium shells**
- **Superior flourosilicone seals provide maximum tear resistance and sealing memory**
- **Threaded coupling with self locking for anti-vibration integrity**

Military circular connector qualified to MIL-DTL-38999, Series III for fiber optic MIL-T-29504 style termini. Rugged design offers maximum performance for shock and vibration, environmental, moisture and corrosion resistance and provides effective EMI shielding.



## MC3 MKII Fiber Optic Multiway Connectors

### MC3 MKII Fiber Optic Multiway Connectors

#### Product Facts

- **Insert-to-insert keying assists precision alignment**
- **Individually rear insertable/removable optical contacts enable easy assembly**
- **Backshells and adaptors available for most single and multifiber cable types**

#### General Specifications

**Fiber type** – Multi and Singlemode fiber

Ranging from 5 to 200µm core diameters

**Channels** – 5, 8 and 12 Optical channels

**Cable size** – 1.5 mm to 3.0 mm outer jacket

#### Materials

**Shell** – Aluminium; nickel plated

Aluminium; cadmium plate olive drab

Aluminium bronze (special order)

#### Contact body

**Arcap** – Titanium

**Ferrule** – Zirconia

**Alignment sleeve** – Zirconia

**Seals** – Fluorosilicone or nitrile

**Plating** – Aluminium, nickel plated

Aluminium, cadmium plate olive drab

Aluminium bronze (special order)

#### Optical Performance

**Insertion loss** - 0.25dB typical\*

**Return loss** - 40dB typical\*

**Repeatability** - Typically better than 0.1db with 50/125µm fiber

#### Environmental Specification

##### Temperature

**High temperature endurance** - +155°C\*

**Low temperature endurance** - 65°C\*

**Durability** - Greater than 500 mating cycles

##### Vibration

**Sinusoidal** - 5-3000Hz, 30g

**Bump** - 4000 bumps, 40g

The MC3 range of high performance connectors incorporates individual optical contacts inserted from the rear.

The removable socket insert allows for easy access to the optical faces to aid cleaning and maintenance.

The MC3 MkII range has the same removable alignment insert feature as the MC3 for easy cleaning (which can be specified in either receptacle or plug), and is suitable for use with most single-mode and multimode optical fibres with core diameters from 5 to 200µm. 5, 8 and 12 optical channels are accommodated in the MIL-C-38999 Series III style connector shells. The MC3 MkII connector range has been tested and approved for use in severe environments.

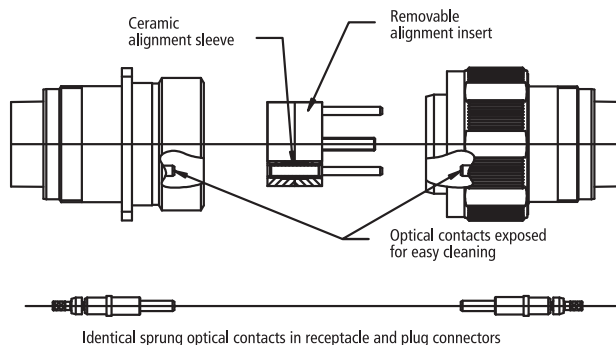

#### Key Features

- Precision Zirconia ceramic ferrules and alignment sleeves ensure superior, repeatable optical performance with physical contact polishing techniques
- Insert-to-insert keying assists precision alignment
- Individually rear insertable/removable optical contacts enable easy assembly
- Easily removable alignment sleeve insert facilitates simple cleaning and maintenance
- Colored band indicates full mating
- Identical optical contacts are spring loaded in both plug and receptacle to maintain physical contact even under severe shock or vibration conditions (rigid contact option available for receptacle)
- Simple termination process and tooling
- Backshells and adaptors available for most single and multifiber cable types
- MIL-C-38999 Series III anti-vibration coupling mechanism and tri-start thread
- Alternative shell keyway orientations provide protection from inadvertent mis-mating
- Dynamic 'O' ring seal between mating shells provides water submersion capability

\*fiber and polishing process dependent

**MC3 MKII Fiber Optic Multiway Connectors** (Continued)

**Insert Arrangement**

Size - Arrangement	A	B1	B2	C1	C2	D	Thread E	Thread F tri-start dimensions (inches)	ØG	ØH	ØJ	ØK	ØL
19-5	36.58	29.35	26.98	5	3.5	27.84	M28 x 1.0	1.250	37.92	27.7	35.4	36.92	29.46
23-8	42.98	34.92	31.75	6.23	4	33.84	M34 x 1.0	1.500	44.12	33.7	41.75	43.12	35.81
25-12	46.02	38.11	34.92	6.23	4	36.84	M37 x 1.0	1.625	47.35	36.7	44.93	46.35	38.99

**Dimensional Information**

All dimensions in inches (except threads). To complete part number for ordering see 'ordering information'

**Plug**

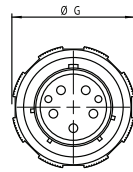

MC306E2

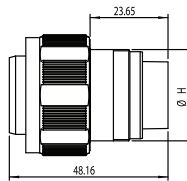

**Procap**

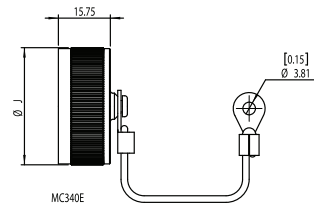

MC340E

**Receptacle**

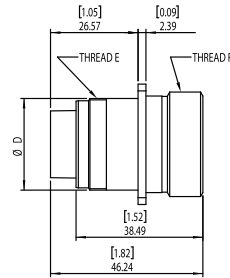

MC300E2

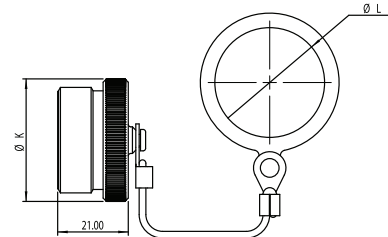
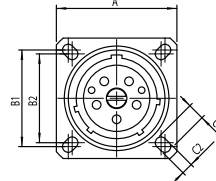

MC320E

**Dummy Receptacle**

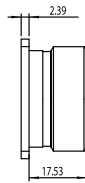

MC330E

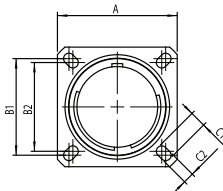

## MC3 MKII Fiber Optic Multiway Connectors (Continued)

### Optical Contacts (ordered separately)

Optical contacts are supplied with a profile formed optical end face and are available for singlemode or multimode fibers. Contacts are available in either sprung or rigid versions, depending upon application (rigid contacts should be used in bulkhead receptacles only).

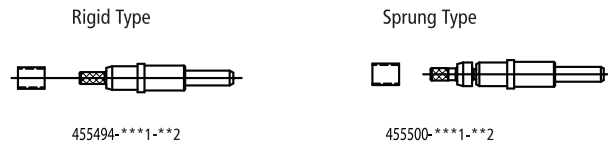

Optical Contacts (ordered separately)

Options are as follows:

\*\*\*1 Optical hole Ø 'A' fiber size (see table 1)

\*\*2 Cable type (see table 2)

Please note: for type 00 (\*\*2) the cable crimp sleeve is not supplied i.e. for terminating buffered fiber.

**Table 1 (\*\*\*)**

Rigid Contact		Sprung Contact	
Part number (multimode) 455***-***1-**2	Part number (singlemode) 455***-***1-**2	Part number (multimode) 455***-***1-**2	Part number (singlemode) 455***-***1-**2
455494-128-**2	455617-126-**2	455500-128-**2	455500-128-**2
455494-145-**2	455617-127-**2	455500-145-**2	455500-145-**2
455494-162-**2		455500-162-**2	
455494-176-**2		455500-176-**2	
455494-232-**2		455500-232-**2	
455494-283-**2		455500-283-**2	
455737-232-**2		455500-1MM-**2	
		455738-232-**2	

**Table 2 (\*\*\*)**

Contact Type		Cable Type		Crimp Dies (see note)		
Rigid	Sprung	Plain buffer	Tight jacket cable	Crimp Sleeve	Part number	A / F
455494-***1-00	455500-***1-00	900µm-	-	-	455608	1.64 / 1.74
455617-***1-00	455616-***1-00	900µm	-	-	455608	1.64 / 1.74
455494-***1-01	455500-***1-01	-	Ø2.5 OD	455610-01	455608	3.10 / 3.12
455617-***1-01	455616-***1-01	-	Ø2.5 OD	455610-01	455608	3.10 / 3.12
455494-***1-02	455500-***1-02	-	Ø1.8 OD	455610-02	455608	3.10 / 3.12
455617-***1-02	455616-***1-02	-	Ø1.8 OD	455610-02	455608	3.10 / 3.12
455494-***1-03	455500-***1-03	-	Ø3.0 OD	455610-03	455608	3.56 / 3.48
455617-***1-03	455616-***1-03	-	Ø3.0 OD	455610-03	455608	3.56 / 3.48
455494-***1-04	455500-***1-04	-	Ø2.1 OD	455610-04	455608	3.10 / 3.12
455617-***1-04	455616-***1-04	-	Ø2.1 OD	455610-04	455608	3.10 / 3.12
-	455500-1MM-00	-	Ø2.2 OD	-	455697	2.62 / 2.72
455737-***1-00	455738-***1-00	-	Ø1.5 OD	-	455478	2.27 / 2.37

Please note: for alternative sizes, please consult technical sales.

Cable Type / Description	Cable Ø O/D mm
Multiway cable, with 900µm buffered fiber and peripheral strain relief	3.5
	4.5
	5.0
	5.5
	6.0
Multiway cable, various constructions - e.g. central strain relief	7.0
	Backshells are available for a range of multiway cables, please consult technical sales

Please note: Crimp dies are used with crimp tool 451716 (Erma 29020).

**MC3 MKII Fiber Optic Multiway Connectors** (Continued)

**Ordering Information**

**Series:**

**Style:**

- 00 = Bulkhead receptacle
- 06 = Plug
- 07 = Jam nut receptacle
- 20 = Protective plug
- 30 = Dummy receptacle
- 40 = Protective cap receptacle

**MkII:**

2 for 00 Bulkhead receptacle, 06 plug and 07 Jam nut Receptacle only. Otherwise omitted

**Shell finish:**

- N = Nickel plated
- C = Cadmium plated olive drab

**Shell size - no. of channels:**

19-5, 23-8, 25-12

**Insert type**

P, S (S type includes the removable alignment insert)

**Shell orientation:**

N, B, C, E, F and 'U' Universal

**Modification code:**

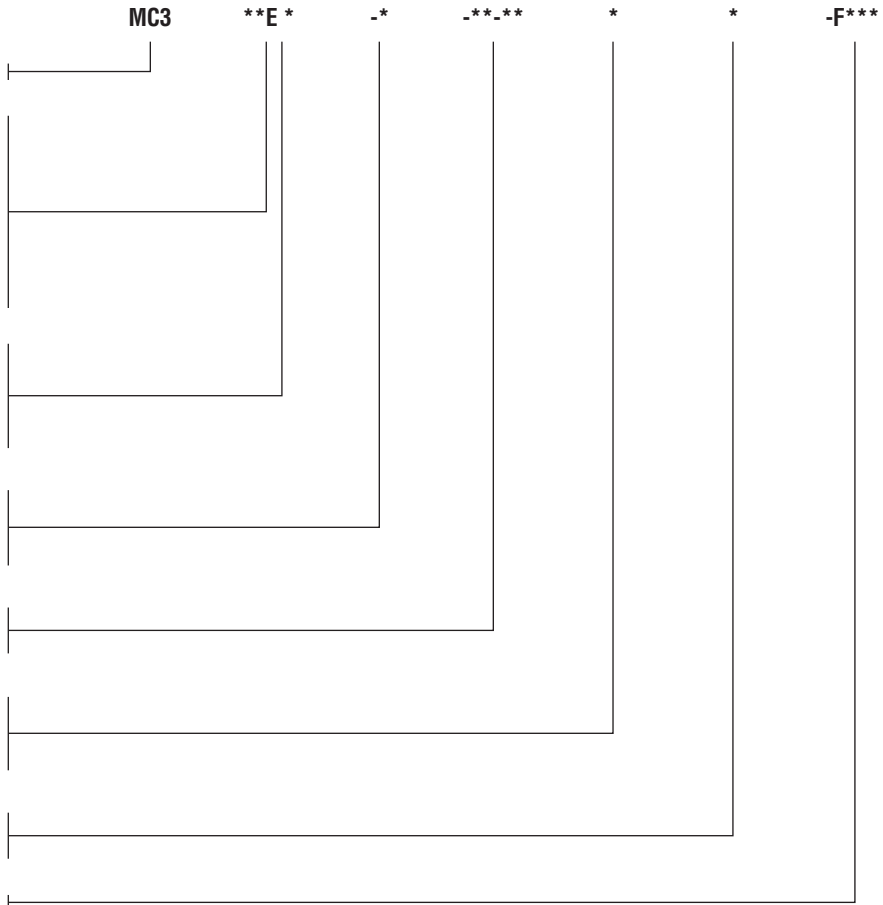

**Example part numbers:**

- Connector MC300E2-N-19-5SN
- Protective cap MC340E-N-19
- Dummy receptacle MC330E-N-19

**Accessories / Essential Tooling Information**

For comprehensive tooling and consumable listing refer to technical sales.

**Quality Approvals**

- Civil Aviation Authority A8-1
- BS EN ISO 9001
- Military Spec Approvals 38999
- BS9000 and CECC
- Underwriters Laboratories
- BS EN ISO9001:2000 (BSI)
- BS/EN 9100:2003 (BSI)
- AS9100 Rev B (BSI)
- AS9120:2002 (BSI)
- EASA Part 21 Subpart G (CAA)
- BS9000 (BSI)
- Underwriters Laboratories (UL)
- Military Spec Approvals 38999 (DSCC)

**MC4 Series - Duplex Fiber Optic Connectors**

**MC4 Series - Duplex Fiber Optic Connectors**

**Product Facts**

- **Insert-to-insert keying assists precision alignment**
- **Individually rear insertable/removable optical contacts enable easy assembly**
- **Backshells and adaptors available for most single and multifiber cable types**

**General Specifications**

**Optical**

**Attenuation** – Less than 0-4dB (50/125µm)

**Repeatability** – Better than 0.2dB

**Fiber types** – 50, 62.5, 85/125µm  
100/140µm 200/280µm

**Cable types**

Tight jacket 2.5mm dia

Duplex 4.5mm OD

For other cable sizes consult Technical Sales

**Materials**

**Shell** - Aluminium alloy. Nickel plated

**Ferrule** - Zirconia Alignment sleeve: Zirconia

**Seals** - Fluorosilicone

**Backshells** - Aluminium alloy. Nickel plated Mechanical

**Temperature range** -65°C to +155°C\*

The MC4 Duplex optical fiber connector is based upon shell size 9 Mil-C 38999 Series III making this an extremely compact environmentally sealed 2-way connector. The MC4 is suitable for use with most multimode and singlemode fibers with core diameters of 9 to 200µm. Simplex and duplex constructions can

be accommodated with suitable connector backshells.

Precision ceramic ferrules and alignment sleeves ensure optical performance and reliability over an extended service life.

The optical ferrules are sprung loaded in both the plug and receptacle shells.

This provides an axial load equalization ensuring that butt joint contact is maintained even when the connector is subjected to vibration levels in excess of 30g.

This coupling nut is built in antivibration clicker mechanism to prevent inadvertent uncoupling under adverse vibration conditions.



**Quality Approvals**

- Civil Aviation Authority A8-1
- BS EN ISO 9001
- Military Spec Approvals 38999
- Underwriters Laboratories (UL)

**Backplane Module - PN 2000973-1**

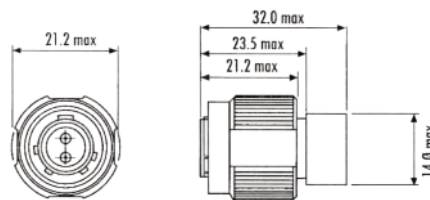

**Daughtercard Module - PN 2000974-1**

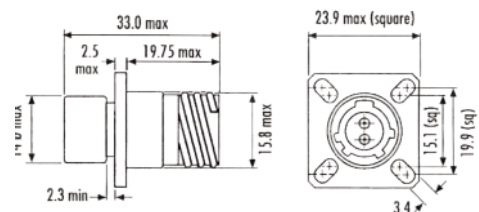

\*Cable and epoxy dependant  
Mechanical endurance: Not less than 500 matings



**MC4 Series - Duplex Fiber Optic Connectors** (Continued)

**Ordering Information**

**Series:**

**Style:**

00 = Bulkhead receptacle  
06 = Plug  
07 = Jam nut

**Shell finish:**

N = Nickel plated  
C = Cadmium plated olive drab

**Shell size - no. of channels** – 09-2

**Insert type** – P Pin, S Socket

**Shell orientation** – N, A, B, C, D, E

**Modification code**

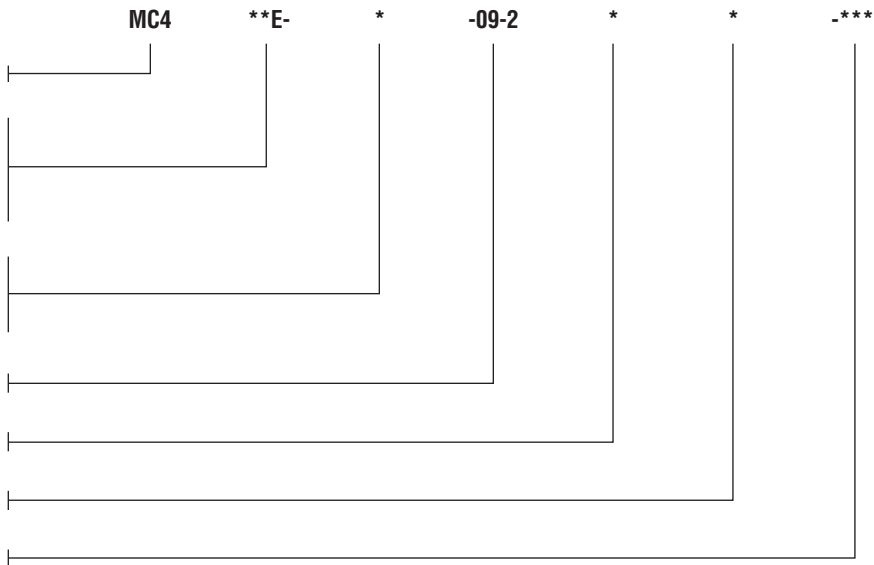

Example part number: Bulkhead Receptacle MC400E-C-09-2SN, Plug MC406E-C-09-2PN

**MC4 Essential Tooling**

Part No.	Description and Use	Notes
<b>Connector Assembly Tooling</b>		
454335	Fiber stripping tool	Hozan
453228	Fiber cleaving tool	
454342	Crimp tool	
<b>Polishing Tools and Materials</b>		
454899	Polishing jig	
454539	Rubber pads	2 required
454539	Lapping film set comprises:	
454481	Coarse disk (10 off)	available separately
454482	DR diamond disc	available separately
454483	DM diamond disc	available separately
454484	Polishing disc (10 off)	
<b>Consumable Materials</b>		
454257	Epoxy kit (353ND)	
450490	Spatula	
454297	Syringe (x6)	
<b>Ferrules</b>		
454900-126	Fiber size 125pm	not supplied with connector
454900-141	Fiber size 140pm	not supplied with connector
454900-145	Fiber size 140pm	not supplied with connector
454900-283	Fiber size 280pm	not supplied with connector

Note: Additional tooling may be required specific to cable types (consult technical sales)  
For comprehensive tooling and consumable listing refer to technical sales

## MC5 - High Density Fiber Optic Multiway

### MC5 - High Density Fiber Optic Multiway

#### Product Facts

- **Insert-to-insert keying assists precision alignment**
- **Individually rear insertable/removable optical contacts enable easy assembly**
- **Backshells and adaptors available for most single and multifiber cable types**

#### General Specifications

**Fiber type** – Suitable for fibres with core diameters 5-200um

**Channels** – 2, 4, 6, 8, 10, 18, and 30 channels

**Cable size** – 1.8 mm, 2.1 mm and 2.5 mm jacket

#### Materials

**Shell** – Composite (qualified to MIL-C-38999)

**Contact body** – Arcap

**Ferrule** – Zirconia

**Alignment sleeve** – Zirconia

**Seals** – Fluorosilicone

**Plating** – Nickel plate

#### Optical Performance

**Insertion loss** - 0.25dB typical\*

**Return loss** -40 dB typical

**Repeatability** - Typically better than 0.1dB (with 50/125µm fiber)

#### Environmental Specification

##### Temperature

**High temperature endurance** - +150°C, 760 hours

**Low temperature endurance** -65°C, 500 hours

**Durability** - >1500 mating cycles

##### Vibration

**Sinusoidal** - 5-3000Hz, 40g, 10 hours

**Random** - 25-2000Hz, 5g2/Hz (50g rms), 16 hrs

The MC5 high density range is the very latest advance in high performance multi-channel fiber optic connectors, capable of sustained performance over a wide range of environmental conditions. The MC5 uses the most recent developments in precision ceramic ferrules and lightweight

MIL-C-38999 Series III connector shell materials, combined with purpose designed inserts to ensure the optical performance meets the requirements of high reliability optical systems. Compact sprung loaded, precision optical contacts are individually insertable / removable for

ease of assembly. Extensive testing has confirmed excellent performance under the most demanding environmental conditions with the MC5 chosen as the standard multiway fiber optic connector for the European Fighter Aircraft, Typhoon.



#### Key Features

- Compact 1.25mm precision zirconia ceramic ferrules
- Alignment sleeves ensure superior, repeatable optical performance with physical contact polishing techniques
- Purpose designed inserts, and insert-to-insert keying assist precision alignment
- Individually rear insertable / removable optical contacts enable easy assembly and maintenance
- Easily removable alignment sleeve insert facilitates simple cleaning and maintenance
- Color band indicates full mate condition
- Identical optical contacts are sprung loaded in both plug and receptacle to maintain physical contact even under severe shock or vibration conditions (rigid contact option available for receptacle)
- Simple termination process and tooling
- Composite lightweight, high strength, corrosion resistant connector shells
- MIL-C-38999 Series III anti-vibration coupling mechanism, and tri-start thread
- Extensive range including 1,2,4,6,8,10 and 30 way connectors
- Available in both plug socket / receptacle pin and plug pin / receptacle socket configurations

\*fiber and polishing process dependent

**MC5 - High Density Fiber Optic Multiway (Continued)**

**Dimensional Information**

All dimensions in inches (except threads). To complete part number for ordering see 'ordering information'.

**Plug**

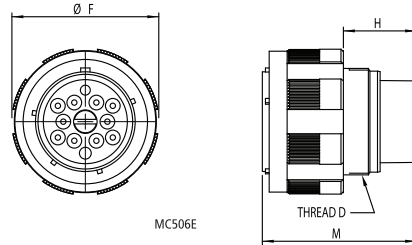

**Procap**

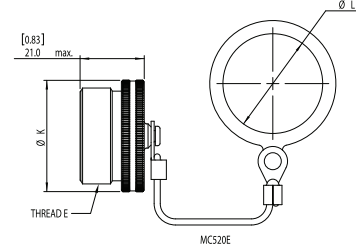

**Receptacle**

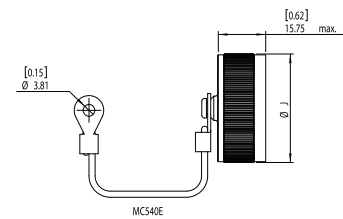
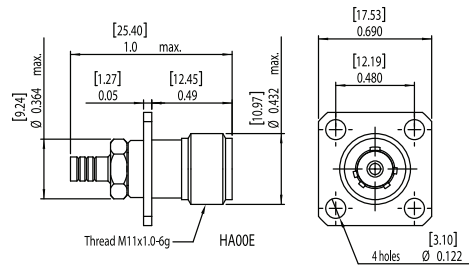

**Dummy Receptacle**

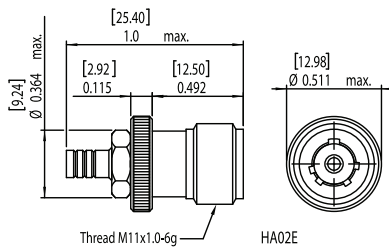

**Dimensional Information (cont)**

Size - Arrangement	A Max	B1	B2	C1 Min	C2 Min	Thread D	Thread E tri-start dimensions (inches)	ØF Max	G Max	H Max	M Max	ØJ Max	ØK Max	ØL Min
11-2	26.4	20.62	18.26	4.84	3.16	M15 X 1.0	0.75000	24.94	3.52	19.9	40.86	N/D	N/D	16.51
13-4	28.81	23.01	20.62	4.84	3.16	M18 X 1.0	0.8750	29.34	3.52	19.9	40.86	26.06	27.56	19.56
15-6	31.2	24.61	23.01	4.31	3.16	M22 X 1.0	1.0000	32.46	3.52	19.9	40.86	N/D	N/D	22.86
17-8	33.51	26.97	24.61	4.84	3.16	M25 X 1.0	1.1875	35.66	3.52	19.9	40.86	34.16	35.46	26.04
19-10	36.71	29.36	26.97	4.84	3.16	M28 X 1.0	1.2500	38.46	3.52	19.7	40.86	35.66	37.16	29.21
21-18	39.91	31.75	29.36	4.84	3.16	M31 X 1.0	1.3750	41.66	4.33	19.7	40.86	N/D	N/D	32.39
23-24	43.11	34.93	31.75	6.06	3.83	M34 X 1.0	1.5000	44.86	4.33	19.7	40.86	42.06	43.36	35.56
25-30	46.21	38.1	34.93	6.06	3.83	M37 X 1.0	1.6250	47.98	4.33	19.7	40.86	45.16	46.6	38.74

## MC5 - High Density Fiber Optic Multiway

### MC5 Optical Termini (ordered separately)

Optical contacts are supplied with a profile formed optical end face and are available for singlemode or multimode fibers. Contacts are available in either sprung or rigid versions, depending upon application (rigid contacts should be used in bulkhead receptacles only).

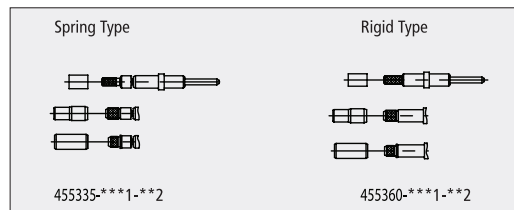

Options are as follows:

\*\*\*1 = Optical hole Ø 'A' (fiber size) (see table 1) \*\*2 = Cable type (see table 2)

Please note: for type 00 (\*\*2) the cable crimp sleeve is not supplied i.e. for terminating buffered fiber.

**Table 1 (\*\*\*1)**

Sprung contact part number	Rigid contact part number
455335-***1-**2	455360-***1-**2
455335-125-**2	455360-125-**2
455335-126-**2	455360-126-**2
455335-127-**2	455360-127-**2
455335-128-**2	455360-128-**2
455335-144-**2	455360-144-**2
455335-159-**2	455360-159-**2
455335-172-**2	455360-172-**2
455335-175-**2	455360-175-**2

**Table 2 (\*\*\*2)**

Contact		Contact		Crimp Dies (see note)	
Sprung	Rigid	Plain buffer	Tight jacket cable	Part number	A / F
455335-***1-00	455360-***1-00	900µm	-	457440	1.25 / 1.35
455335-***1-01	455360-***1-01	-	Ø2.1 OD	457440	2.27 / 2.37
455335-***1-02	455360-***1-02	-	Ø1.8 OD	457440	2.62 / 2.52 and 2.37 / 2.27
455335-***1-0	455360-***1-03	-	Ø2.5 OD	457440	2.74 / 2.84

Please note: for alternative sizes, consult technical sales.

### MC5 Backshells for Multiway Cables (ordered separately)

Cable Type / Description	Cable Ø O/D mm
Multiway cable, with 900µm buffered fiber and peripheral strain relief	3.5
	4.5
	5.0
	5.5
	6.0
	7.0
Multiway cable, various constructions - e.g. central strain relief	Backshells are available for a range of multiway cables, please consult technical sales

Please note: Crimp dies are used with crimp tool 451716 (Erma 29020).

**MC5 - High Density Fiber Optic Multiway** (Continued)

**Ordering Information**

**Series:**

**Style:**

- 00 = Bulkhead receptacle
- 06 = Plug
- 07 = Jam nut
- 20 = Protective cap plug
- 30 = Dummy receptacle
- 40 = Protective receptacle

**Shell finish:**

N Nickel plated

**Shell size - no. of channels:**

- 11-2, 13-4, 15-6, 17-8, 19-10, 21-18,
- 23-24, 25-30

**Insert type**

P, S (S type includes the removable alignment insert)

**Shell orientation:**

N, A, B, C

**Modification code:**

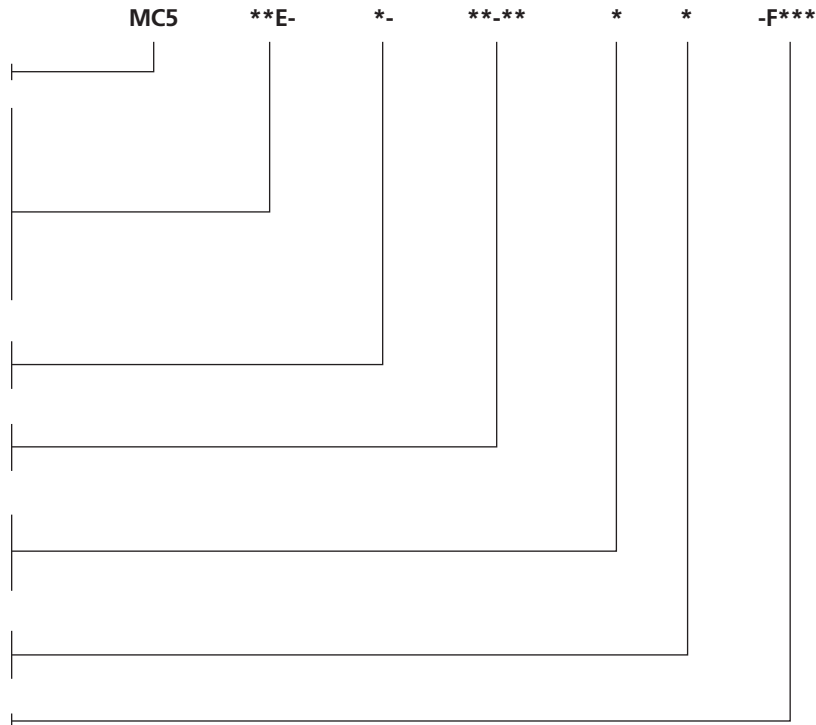

**Example part numbers:**

- Connector MC500E-N-17-8SN
- Protective cap MC540E-N-17
- Dummy receptacle MC530E-N-17

**Accessories / Essential Tooling Information**

MC5 Fiber Optic Module for DMC-M Connectors

The MC5 DMC-M high performance fiber optic modules are manufactured from a high performance material for corrosion resistance and features a rugged construction. The common MC5 optical contact is rigid or sprung loaded and common to both plug and receptacle to maintain physical contact even under severe shock or vibration.

**Quality Approvals**

- Civil Aviation Authority A8-1
- BS EN ISO 9001
- Military Spec Approvals 38999
- BS9000 and CECC
- Underwriters Laboratories
- BS EN ISO9001:2000 (BSI)
- BS/EN 9100:2003 (BSI)
- AS9100 Rev B (BSI)
- AS9120:2002 (BSI)
- EASA Part 21 Subpart G (CAA)
- BS9000 (BSI)
- Underwriters Laboratories (UL)
- Military Spec Approvals 38999 (DSCC)

## MC6 - Fiber Optic Ribbon Cable Connector

### MC6 - Fiber Optic Ribbon Cable Connector

#### Product Facts

- **Insert-to-insert keying assists precision alignment**
- **Individually rear insertable/removable optical contacts enable easy assembly**
- **Backshells and adaptors available for most single and multifiber cable types**

#### Fiber Type:

**Channels** – 2 to 72

**Cable size** – Telecom grade cable  
Aerospace grade cable

#### Materials

**Shell** – Composite (MIL-C-38999)

**Contact body** – Nickel/cadmium plated composite polymer

**Ferrule** – Thermoplastic

#### Alignment Pin:

**Seals** – Fluorosilicone

**Plating** – Nickel

The MC6 high density, fiber optic connector series is now further enhanced with the option for industry standard MT Ferrule inserts. The insert accommodates 2 to 72 channels and can be supplied pre-terminated if required. The MC6 uses the

compact MIL-C-38999 Series III, shell size 11 body, also used on the proven MC5 connector. It has a lightweight, corrosion resistant, metal-plated composite shell which provides high strength and durability, combined with EMC shielding.

The result is a very compact, rugged, environmentally sealed solution for a wide range of applications, such as avionics, data bus and in-flight entertainment systems.



#### Key Features

- Common contact single or multimode MT ferrules MIL-C-38999 Series III anti-vibration coupling with tri-start thread
- Easily accessible Angled Physical Contact (APC) and Physical Contact (PC) faces for cleaning and maintenance
- Rear release contact using size 8 extraction tools Retrofit triple rear seal available
- Color band indicating full mating
- The use of industry standard MT interface and a variety of housing options ensures integration into new and existing systems
- Interchangeable with MIL-C-38999 Series III

**MC6 - Fiber Optic Ribbon Cable Connector (Continued)**

**Optical Performance**

For more information contact technical sales on +44 (0) 1424 858358 or fiber@deutsch.net

**Dimensional Information**

All dimensions in millimeters unless otherwise stated. To complete part number for ordering see Ordering Information.

**MC6 Receptacle**

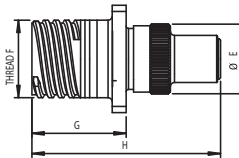
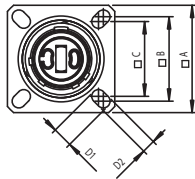

**Protective Cap Receptacle MC640E-N-11**

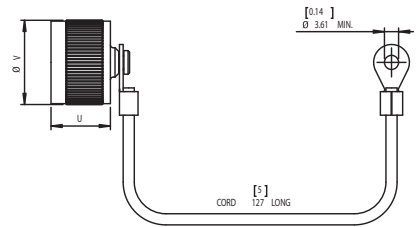

**MC6 Plug**

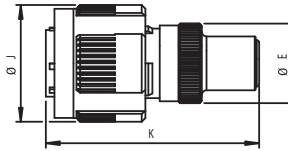

**Procap Plug MC620E-N-11**

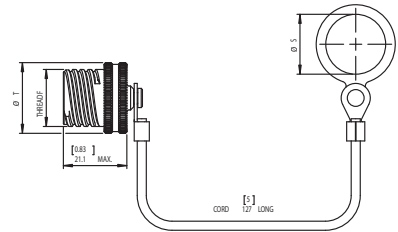

**Jam Nut**

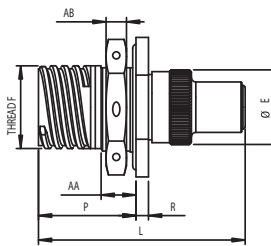
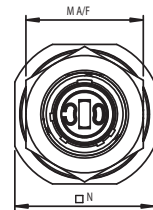

**Protective Cap Receptacle**

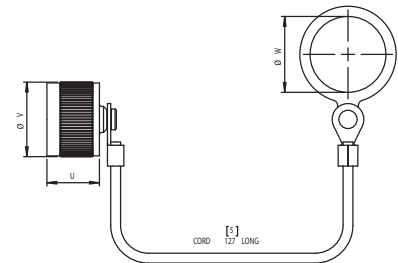

**Dummy Receptacle MC630E-N-11**

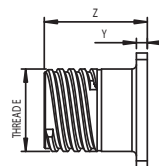
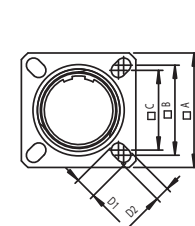



**MC6 - Fiber Optic Ribbon Cable Connector** (Continued)

**Contact and Tooling Information**

A Max	B Nom	C Nom	D1 Min	D2 Min	ØE Max	Thread F Tri-start (inches)	G Max	H Max	ØJ Max	K Max	L Max
26.40	20.62	18.26	4.84	3.16	17.10	0.7500"	23.20	46.50	24.95	46.00	47.50

M A/F	N Max	P Max	R Max	ØS Min	ØT Max	U Max	ØV Max	ØW Min	ØX Max	Y Max	Z Max	AA Max	AB Max
27	32.00	22.30	2.96	19.55	23.46	16.16	22.96	22.86	8.01	2.76	23.76	7.80	4.81

**Ordering Information**

**Series:**

**Style:**

- 00 = Bulkhead receptacle
- 06 = Plug
- 07 = Jam nut

**Shell finish:**

- N Nickel plated
- C = Cadmium plated

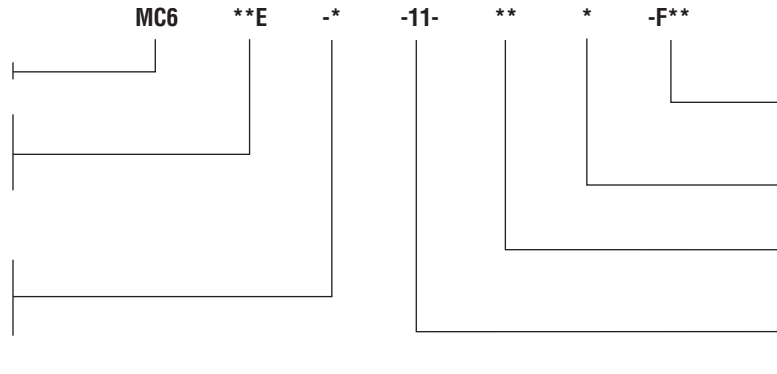

**Optical Termini**



MC6 MT contact

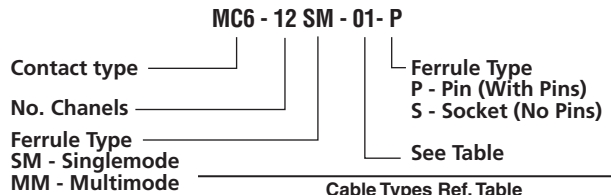

Cable Types Ref. Table		
Part No.	Cable	
	Description	Jacket Size
MC6 - *** - 01*	Ruggedized Aerospace Oval Multi Fiber Cable	3.95mm x 1.60mm Max.
MC6 - *** - 02*	Round Multi Fiber Cable	Ø3.96mm Max.

**Accessories / Essential Tooling Information**

MC6 Fiber Optic Module for DMC-M Connectors

The MC6 DMC-M high performance fiber optic modules are manufactured from a high performance material for corrosion resistance and features a rugged construction. The common MC6 optical contact is rigid or sprung loaded and common to both plug and receptacle to maintain physical contact even under severe shock or vibration.

**Quality Approvals**

- Civil Aviation Authority A8-1
- BS EN ISO 9001
- Military Spec Approvals 38999
- BS9000 and CECC
- Underwriters Laboratories
- BS EN ISO9001:2000 (BSI)
- BS/EN 9100:2003 (BSI)
- AS9100 Rev B (BSI)
- AS9120:2002 (BSI)
- EASA Part 21 Subpart G (CAA)
- BS9000 (BSI)
- Underwriters Laboratories (UL)
- Military Spec Approvals 38999 (DSCC).

## MC801 Connector

### MC801 Connector

#### Product Facts

- Uses precision ARINC 801 fiber optic termini (typical multi-mode insertion loss is less than 0.15 dB).
- Removable alignment sleeve insert for easy cleaning of fiber optic termini
- Three stages of alignment: shell-to-shell keys, guide pins and ceramic alignment sleeves
- Includes all of the features of standard D38999 straight plug and panel mount receptacle shells
- Scoop-proof connector design
- Option for alternate keys and keyways

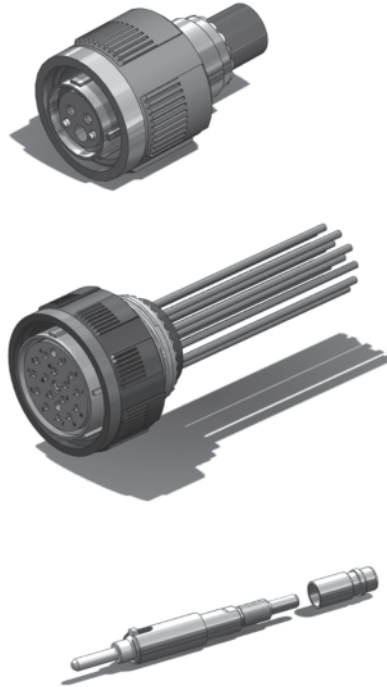

#### Insert Arrangements

11-02 13-04 15-06 17-08

19-12 21-16 23-24 25-32

#### Materials

Composite and Aluminium

#### Finishes

Electroless Nickel and Olive drab cadmium

#### A801 Termini

- Genderless termini allows for use on both sides of a connector
- The Alignment sleeves are contained in a separate carrier which is removable for easier end-face maintenance
- Ultra Precision ceramic ferrules and sleeves ensure accurate fiber-to-fiber alignment
- Termini are keyed to provide anti-rotation
- Termini body is crimped to the cable providing a Pull-Proof solution

#### Performance expected

- Insertion Loss at 850 Nm 0.30 dB max., 0.15 dB typical for multi-mode
- Return Loss 850 Nm -20 dB max - 40 dB typical multi-mode

## Ruggedized Singleway Connector (RSC)

### Ruggedized Singleway Connector (RSC)

#### Product Facts

- **Insert-to-insert keying assists precision alignment**
- **Individually rear insertable/removable optical contacts enable easy assembly**
- **Backshells and adaptors available for most single and multifiber cable types**

**Fiber Type** – 8, 50, 62.5, 85/125µm  
 100/140µm  
 200/230µm  
 200/280µm  
 200/300µm

**Cable size** – 1.6mm to 5mm  
 Simplex tight jacket Kevlar reinforced secondary buffered fiber

#### Materials

**Shell** – Arcap  
**Contact body** – Arcap  
**Ferrule** – Zirconia  
**Alignment sleeve** – Zirconia  
**Seals** – Fluorosilicone  
**Plating** – Nickel

#### Optical Performance

**Insertion loss** – 0.25dB typical  
**Return loss** – -40dB typical\*  
**Repeatability** – Better than 0.2dB

#### Temperature

**High temperature endurance** – +155°C\*  
**Low temperature endurance** – -65°C\*

**Durability** – not less than 500 matings

TE's RSC range of high performance fiber optic connectors are manufactured from Arcap for corrosion resistance and feature a rugged construction, incorporating environmental sealing and an anti-vibration coupling mechanism. The optical contact is sprung loaded and common to both plug and receptacle to maintain physical contact even under severe shock or vibration. The RSC range is suitable for both singlemode and multimode applications, and features easily accessible fiber faces for cleaning purposes.

#### Key Features

- Precision Zirconia ceramic ferrule and alignment sleeve to ensure superior repeatable optical performance with physical contact polishing techniques
- Manufactured from Arcap for corrosion resistance
- Easy access to ferrule to facilitate simple cleaning and maintenance
- Common ferrule carriers for the plug and receptacle
- Optical contact is sprung loaded in both the plug and receptacle to maintain physical contact even under severe shock or vibration
- Simple termination process and tooling
- Anti-vibration coupling mechanism
- Six alternative shell keyway orientations provide protection from inadvertent mis-mating
- Able to accommodate various sizes of multimode and singlemode fiber - (8/125, 50/125, 62.5/125, 100/140, 200/280mm)
- Able to accommodate various sizes of simplex cable (1.6mm - 5mm)
- Compatible with HA Connector series



### Ruggedized Singleway Connector (RSC) (Continued)

#### Dimensional Information

All dimensions in inches (except threads). To complete part number for ordering see 'ordering information'

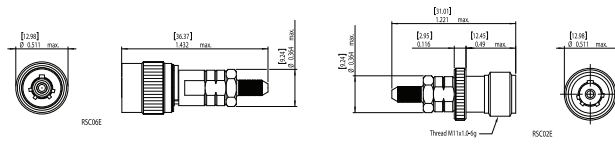

#### Plug

#### Free Receptacle

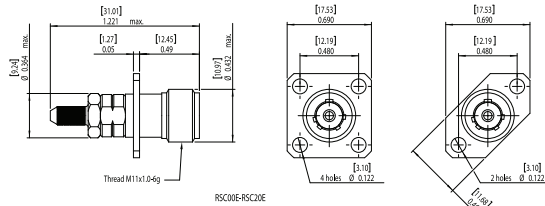

#### Receptacles

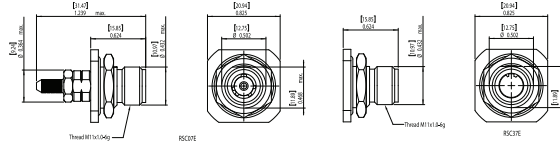

#### Jam Nut Receptacle

#### Dummy Receptacle

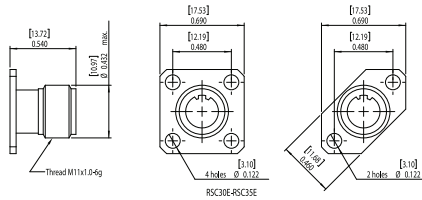

#### Dummy Receptacles and Mounting

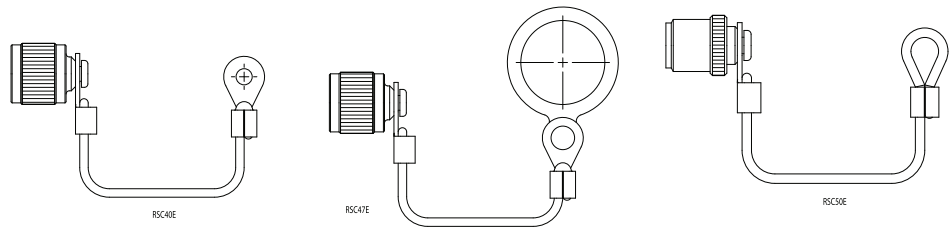

#### Procap

**Ruggedized Singleway Connector (RSC) (Continued)**

**Ordering Information**

**Series:**

**Shell style:**

- 00 = Bulkhead receptacle
- 06 = Plug
- 07 = Jam nut
- 20 = Protective cap plug
- 30 = Dummy receptacle
- 40 = Protective receptacle

**Shell orientation:**

N, A, B, C, D, E

\*Special glass braid

For other cable types, please consult the sales office.

Example part number: RSC06E-N-100  
RSC plug, 'N' orientation, 2.5mm cable

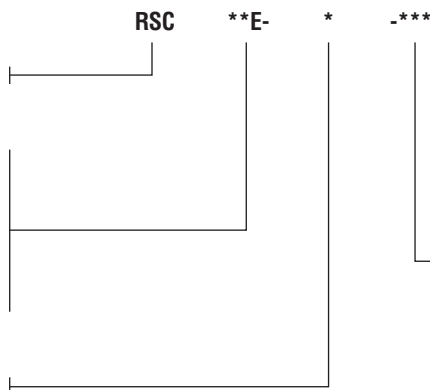

- 100 cable diameter 2.5mm O/D
- 180 cable diameter 1.8mm O/D
- 200 cable diameter 2.0mm O/D
- 300 cable diameter 1.65mm O/D
- 400 cable diameter 3.0mm O/D
- 500 cable diameter 3.2mm O/D
- 600 cable diameter 2.1mm O/D
- 700 cable diameter 1.6mm O/D\*
- 800 cable diameter 3.7mm O/D
- 900 cable diameter 5.0mm O/D

**Optical Contacts**

(Must be ordered separately)

Mode	Fiber size	Part number
Singlemode	8/125µm	456099SM-126
	50, 62.5/125µm	456099-126
	100/140µm	456099-145
	100/172µm	456099-176
Multimode	200/220µm	456099-224
	200/230µm	456099-232
	200/280µm (flat faced)	454103-283
	200/300µm	453800-305

**Accessories**

Fixing	Dummy receptacle part number	Protective cap part number
4 hole	RSC30E	RSC40E
2 hole	RSC35E	
Jam nut	RSC37E	RSC47E

Please contact technical support for termination tools and consumables.

**Hermetic Receptacle (RSC07HE)**

**Key Features**

- Compatible with the RSC plug connector
- Leak rate < 1x10<sup>-6</sup> cc/s
- 125°C temperature rating

**Dimensional Information**

All dimensions in inches (except threads). To complete part number for ordering see 'ordering information'

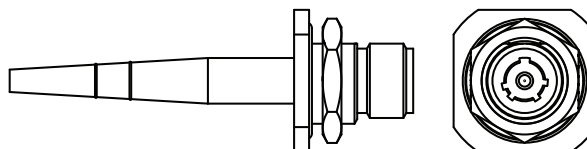

**Ordering Information**

**Series:**

**Shell orientation** - N, A, B, C, D, E

**Fiber size** - 125, 140, 280µm

**Pigtail length** - cms

Example part number: (pigtail cable 900µm buffer only)  
RSC07HE-N-283-100 receptacle, pigtail, 'N' orientation, 280µm fiber, 100cm cable

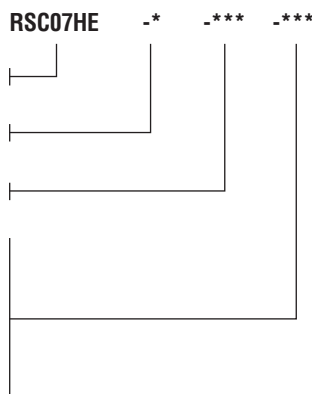

**Quality Approvals**

- Civil Aviation Authority A8-1
- BS EN ISO 9001
- Military Spec Approvals 38999
- BS9000 and CECC
- Underwriters Laboratories
- BS EN ISO9001:2000 (BSI)
- BS/EN 9100:2003 (BSI)
- AS9100 Rev B (BSI)
- AS9120:2002 (BSI)
- EASA Part 21 Subpart G (CAA)
- BS9000 (BSI)
- Underwriters Laboratories (UL)
- Military Spec Approvals 38999 (DSCC)

**Sealed Circular LC ODVA**

**Sealed Circular LC ODVA Conforming Connector**

**Product Facts**

- IP67 rated to ensure protection from dust and water immersion
  - LC connector qualified to Telcordia GR-326 and TIA/EIA 568B.3
  - Temperature range of -40°C to 85°C
  - Bayonet-style mechanical lock
  - Flame retardant materials per UL 94 V-0
  - Dual mounting bulkhead design
  - Singlemode and multimode fiber
  - Can be used with cable types 9/125, 50/125 and 62.5/125
  - LC to LC internal to the box Jumpers
  - LC connector accepts tactical cable with 4.5 mm – 7.5 mm OD
  - ODVA Conforming Plug to X interface on tactical with break out
  - ODVA Conforming Plug to Plug on tactical cable
  - Build to customer need
- Applications**
- The LC ODVA Conforming Connector is ideal for:
- Harsh environments where chemicals, corrosive gases and liquids are commonplace
  - Inside and outside industrial plant and equipment that interface with industrial Ethernet networks
  - Remote interface applications such as towers and antennae as well as FTTX in PON and at the home applications
  - Mobile routers and internet hardware



**Plug Part Numbers:**  
 1828618-1 (Multimode)  
 1828618-2 (Singlemode)

**Receptacle Part Numbers:**  
 1828619-1 (Multimode)  
 1828619-2 (Singlemode)

**Plug & Receptacle Cap Part Numbers:**  
 Plug Cap 1828740-1  
 Receptacle Cap 1918177-1

**ASSEMBLY CAPABILITIES**  
 TE Connectivity has extensive Rugged Optic Harness capabilities. Please consult your local TE Sales representative for assistance.

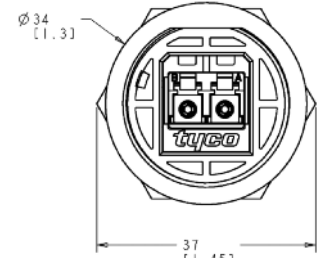
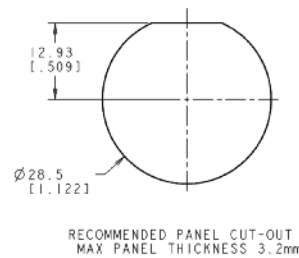
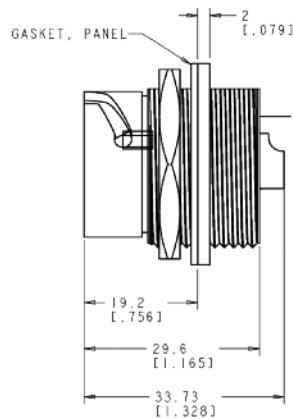
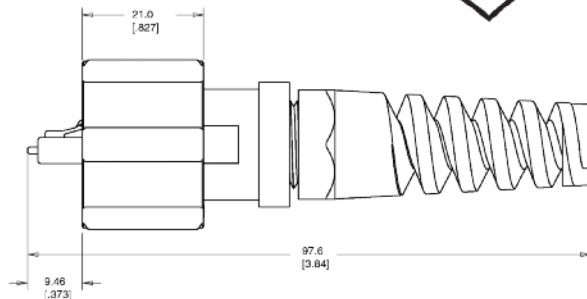
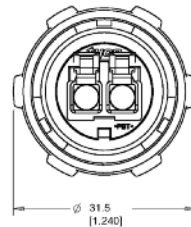

**Standard Cable Assemblies**

Part Number	Description
1828935-X	ODVA LC Interface, 62.5, 2 Fiber
1828936-X	ODVA LC Interface, Singlemode, 2 Fiber

**Note:** X = length in meters

**Note:** All part numbers are RoHS compliant.

### Rugged Circular Connectors

#### EMPIRE

##### Product Facts

- Facilitates the implementation of fiber sensors within composites
- Protection of fiber at composite entry/exit point
- Receptacle connector physically embedded within composite material
- Available as panel edge or surface mount configuration

A unique, patent pending Fiber Optic connector technology that allows designers to reliably connect embedded optical fibers to external monitoring equipment, eliminating the problems of fixed 'flying lead' connections to the structure. See TE.com for additional information.



#### Fiber Optic Cable Assemblies and Harnesses

##### Product Facts

- Custom designs available
- Custom lengths for harnessing
- Dedicated Fiber Optic harness facility
- Capability to work closely with customer to fully define requirements

TE also has dedicated design and manufacturing resources available to provide rugged and reliable Fiber optic harnesses for Aerospace, Military communications, Railways, Autosport and Industrial equipment.





### Rugged Board Level Connector

#### Ruggedized Optical Backplane Interconnect for VITA 66

##### Product Facts

- Receptacle designed to maximize optical performance
- Connectors accommodate up to two MT ferrules
- Locating post features helps ensure proper position on the backplane and module boards
- Common protective cover is made of anti-static material
- Plug (daughtercard) connector housing contains a slot feature to facilitate cleaning the MT interfaces
- Receptacle (backplane) connector includes two robust guide pins for blind-mating
- Receptacle connector insert floats relative to the shell, providing  $\pm 0.25\text{mm}$  planar floating alignment capability
- Connector mounting screws contain pre-applied Nylok patch to withstand vibration

##### Mechanical

**Mating Force (per 12-fiber MT ferrule)** – Min: 7.8N [1.75 lb]  
Max: 11.8N [2.65lb]

**Durability** – 100 cycles, tested per EIA-455-21

**Shock** – 50G, sawtooth, 11 msec pulse duration, tested per TIA/EIA-455-14, condition E

**Random Vibration** – 11.95 G (rms), 50-2000 Hz, 2 hrs per plane - tested per TIA/EIA-455-11, test condition V1-D

##### Materials

**Connector shell & housing** – Aluminum alloy 6061, clear-chromate conversion-coated (RoHS compliant)

**Alignment posts & screws** – Stainless Steel, 300 series, passivated (RoHS-compliant)

TE Connectivity's (TE) Ruggedized Optical Backplane interconnect system provides a high-density, blind-mate optical interconnect in a backplane/daughtercard configuration. The fiber optic (ribbon) cable

interconnect is fedthrough the backplane to removable system modules using MT ferrules. TE offers the optical system in both a receptacle (backplane) and matingplug (daughtercard) connectors which interconnect up to two MT ferrules,each accomo-

dating up to 24 fiber paths. Other options are available using industry standard ARINC 801 fiber terminus and TE's Expanded Beam, Pro Beam interface in a four-fiber configuration.

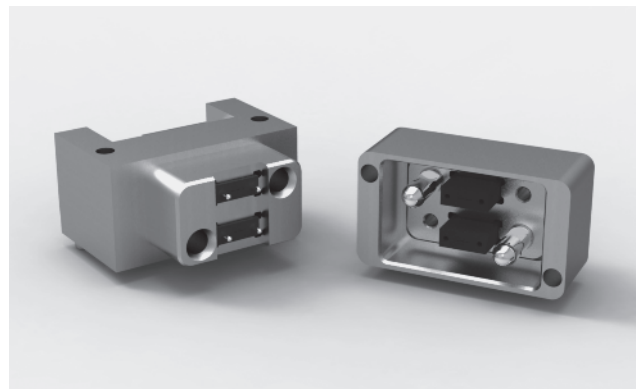

##### Key Features

- Receptacle designed to maximize optical performance
- Connectors accommodate up to two MT ferrules
- Locating post features helps ensure proper position on the backplane and module boards
- Common protective cover is made of anti-static material
- Plug (daughtercard) connector housing contains a slot feature to facilitate cleaning the MT interfaces
- Receptacle (backplane) connector includes two robust guide pins for blind-mating
- Receptacle connector insert floats relative to the shell, providing  $\pm 0.25\text{mm}$  planar floating alignment capability
- Connector mounting screws contain pre-applied Nylok patch to withstand vibration

Interface	Part No.	
	Backplane	Daughtercard
VITA 66.1: MT	2000973-1	2000974-1
MT Ferrule Kit (12 Fiber, Multimode)	2102866-1	2102866-2

Backplane Module - PN 2000973-1

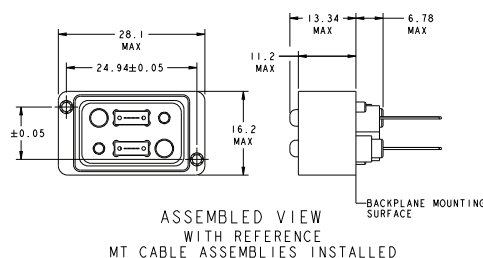

Daughtercard Module - PN 2000974-1

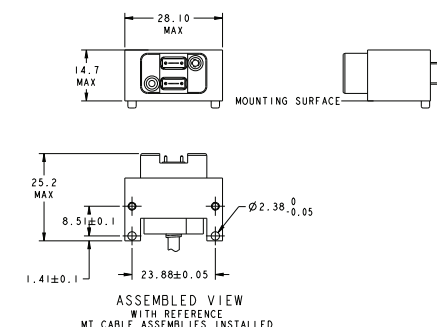

## Navy CID Approved Epoxy Applied

### Tight Jacketed LC Connectors

#### Product Facts

- Multimode or singlemode
- Simplex or duplex
- Tested using MIL-PRF-85045/16 2.0 mm cable
- LC Commercial Item Description (CID) interim approval by the Naval Surface Warfare Center, Dahlgren Division

#### Application

- In Flight Networks
- Shipboard Applications
- Aero Market

The Tight Jacket LC Connector is a robust design for rugged applications including but not limited to:

- Extreme temperatures -55°C to +110°C
- Excessive vibration or physical shock

Test reports available upon request.



The tight jacketed LC Connectors are non pull-proof versions of the standard connectors that are designed for use with tight construction cable. Unlike

standard connectors, this design allows the jacket and buffer to move together, reducing the chances of micro-bends and fiber breakage.

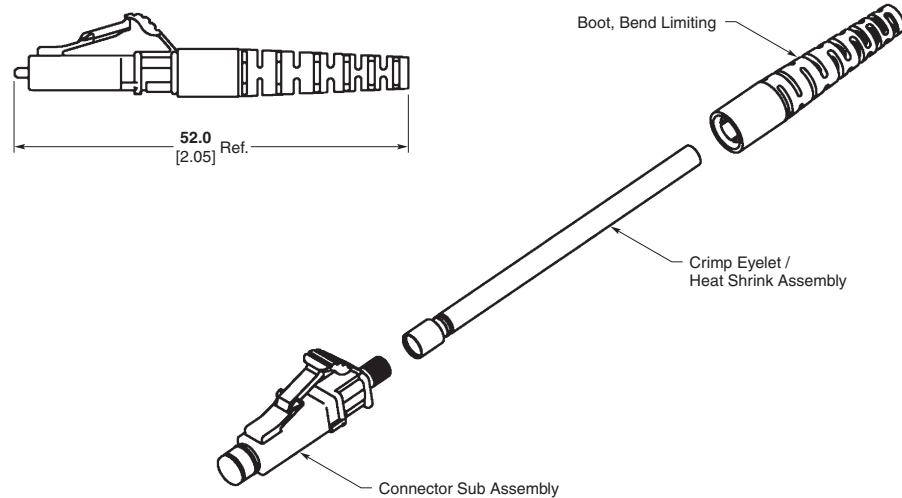

Fiber Type	Kit Part Number	Description
Singlemode (blue body & straight boot)	6828095-X	Simplex, 1.6–2.0 mm
	6828130-X	Duplex, 1.6–2.0 mm
	1918228-X	Simplex, 2.4 mm
	2123524-X	Duplex, 1.6–2.0 mm, transceiver optimized
Multimode (beige body & straight boot)	6828094-X	Simplex, 1.6–2.0 mm
	6828129-X	Duplex, 1.6–2.0 mm
	1918153-X	Simplex, 2.4 mm
	2123265-X	Simplex, 2.4 mm, transceiver optimized

**Note:** X = -1 for individual package, -2 for bulk package.  
 Instruction Sheet 408-10014. See <http://www.te.com/documents>.  
 Duplex Clip Available (Part Number 1754371-1).

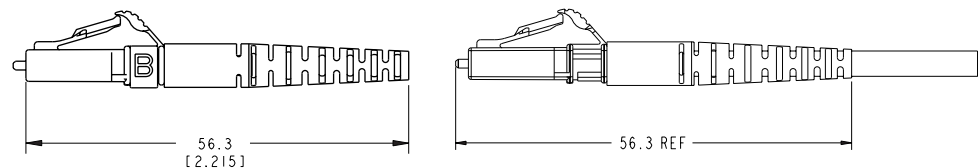

**Note:** All part numbers are RoHS compliant.

SC Connectors

Tight Jacketed SC Connectors

Product Facts

- Multimode or singlemode
- Simplex or duplex
- Tested using MIL-PRF-85045/16 2.0 mm cable
- SC Commercial Item Description (CID) interim approval by Naval Surface Warfare Center, Dahlgren Division

Application

- In Flight Networks
- Shipboard Applications
- Aero Market



The tight jacketed SC Connectors are non pull-proof versions of the standard connectors that are designed for use with tight construction cable. Unlike

standard connectors, this design allows the jacket and buffer to move together, reducing the chances of micro-bends and fiber breakage.

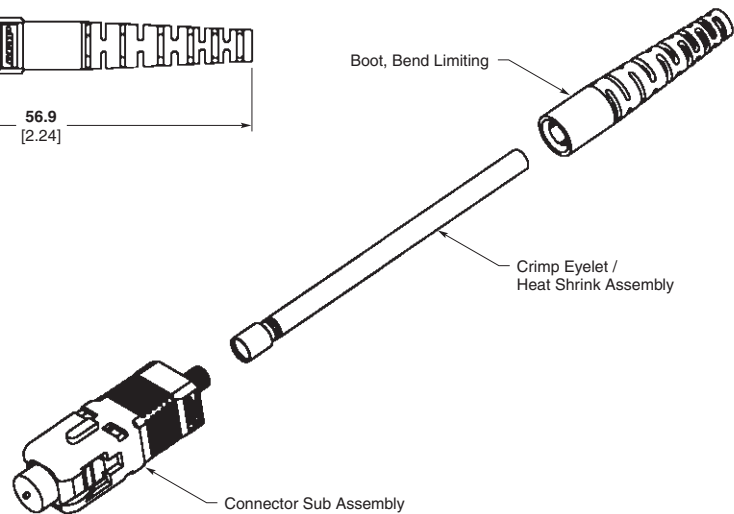
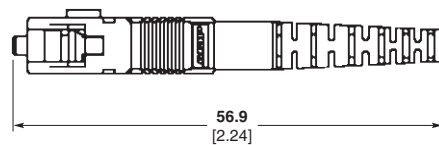

Tight Jacketed SC Connector Kits

Fiber Type	Kit Part Number	Description
Singlemode (blue body & straight boot)	6828100-X	Simplex, 1.6–2.0 mm
	1828573-X	Duplex, 1.6–2.0 mm
	1918227-X	Simplex, 2.4 mm
Multimode (beige body & straight boot)	6828099-X	Simplex, 1.6–2.0 mm
	1828574-X	Duplex, 1.6–2.0 mm
	1918154-X	Simplex, 2.4 mm

**Note:** X = -1 for individual package, -2 for bulk package. Instruction Sheet 408-10015. See <http://www.te.com/documents>.

**Note:** All part numbers are RoHS compliant.

**LC Plus — Navy Approved**

**LC, SC and LightCrimp Plus ST Approved by U.S. Navy for Use On Board Ships**

**LightCrimp Plus ST Fiber Optic Connector Features and Benefits:**

- LightCrimp Plus technology delivers the ability to terminate the fiber optic ST connector with mechanical tools by the ferrule being factory polished and terminated to the connector body
- The mechanical process enables a simple strip, clean, cleave crimp process that improves process time and eases the complexity of the installation

**Termination Kits:**

- The LightCrimp Plus MM ST part 2064757-1 has a dedicated termination kit, part number 2064764-1, suggested for its implementation. TE provides a wide variety of tools required to prepare and terminate LightCrimp Plus ST connectors.

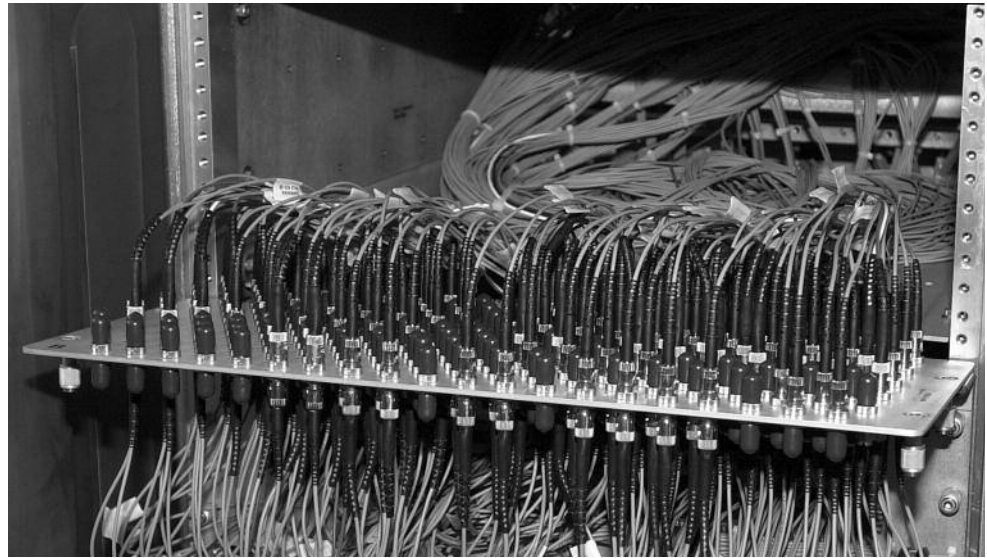

Whether you're designing local area networks, communications systems or equipment, innovative fiber optic applications begin with innovative fiber optic products. TE Connectivity offers a complete line of fiber optic products to help your designs make light work for you.

TE's comprehensive fiber connector line delivers virtually all industry-standard connections, including LightCrimp Plus ST-Style and epoxy applied Tight Jacketed LC and SC and many others. They bring fiber to the desk at a cost that is competitive with copper.

**LightCrimp Plus ST Fiber Optic Connectors**

TE LightCrimp Plus ST-Style connectors are available in single or multimode configurations and can be crimped to the fiber. Any, they can install in under two minutes, without epoxy.

TE recently obtained approval from the U.S. Navy for its Multimode LightCrimp Plus ST Connector. This connector has been added to the "Navy Recommended Fiber Optic Components Parts List" located at <https://fiberoptics.nswc.navy.mil/>,

and is currently listed under the TE part number **(2064757-1)**. In addition, it is listed under the CID number A-A-59917. This approval is the latest in this series and joins the approved status of the LC and SC tight construction epoxy optic connectors listed on the components parts list.



**LightCrimp Plus ST**

\* Commercial Item Description

**LC Plus — Navy Approved** (Continued)

**Combination  
LIGHTCRIMP PLUS  
SC/ST/LC Termination Kit  
Part Number 1985162-1**



**Note:** All part numbers are RoHS compliant.

**LightCrimp Splice**

**Product Facts**

- Terminates 250 µm coated, 900 µm tight-buffered fibers and 2.0 mm jacketed cable
- Attenuation (typical): ≤ 0.1 dB
- Return Loss (at ambient; 18°–28° C): ≥ 20 dB multimode, ≥ 35 dB single-mode
- Operating Temperature: -25 to 70° C
- Storage Temperature: -40 to 85° C
- Tensile retention: 250 µm coated: 2.0 N, 900 µm buffered: 3.0 N, Jacketed: 50.0 N
- Fast, easy fiber splicing
- No epoxy required
- No set-up required
- No workstation required
- Ideal for low-fiber count cables
- Same LightCrimp Splice for single-mode and multimode 125 µm diameter fibers
- Kit includes rugged case



LightCrimp splices provide rugged, miniaturized form-factor that assures consistent crimp quality, dependability, and performance that rivals fusion splices. LightCrimp splices have been tested in accordance with IEC 61300 procedures, with an operating temperature range extending from -25° C to +70° C.

LightCrimp splices have been designed to meet TIA 568-C.3, IEC 61753 Cat U, and EN optical requirements.

LightCrimp splices provide the proven performance based on technology used to install more than one million LightCrimp Plus connectors.

**Navy approved CID commercial item.**  
**Description #A-A59917**

Description	Part Number
LightCrimp Splice for 250 µm, 900 µm and 2.0 mm Jacketed Cable	1985368-1
LightCrimp Splice Termination Tool Kit	2064764-1



**LightCrimp PLUS Kit**  
**Part Number 1985801-1**

Capable of terminating:  
**In Line Mechanical Splice**  
**Part Number 1985368-1**  
and **LightCrimp PLUS LC/SC**

**Part Numbers:**

- 2123277-1 & -2 Simplex MM LC
- 2123278-1 & -2 Duplex MM LC
- 2123279-1 Simplex SM
- 2123280-1 Duplex SM





**Offshore Optical Connectors and Cable Assembly**

**9316 Optic**

**Product Facts**

- Dry Mate connection
- Explosion proof area
- Multiway up to 12 FO
- Operating pressure up to 40 bar
- Single or Multimode fibers can be combined
- Backshell custom design available

9316 series has been designed to withstand the most severe environments in marine and offshore applications.

A special care was taken concerning:

- Easy handling
- Mechanical stress
- Use in polluted environments
- Use in hazardous areas



**Showet**

**Product Facts**

- Hybrid product 4 FO and 4 copper contacts
- SplashZone connector
- Operating pressure up to 80 bar
- Single or Multimode fibers can be combined

Combines optical and copper connectivity in a single shell. Supporting both signals and control copper cabling and single-mode and multimode optical fibers to allow the replacement of multiple connectors by one.



**MOD**

**Product Facts**

- Explosion proof area
- SplashZone connector
- Multiway up to 8 FO
- Operating pressure up to 40 bar
- Single or Multimode fibres can be combined

MOD is an explosion-proof connector suited to topside application, quick connect/disconnect coupling for reliable operation in hazardous environments such as FPSO turrets.

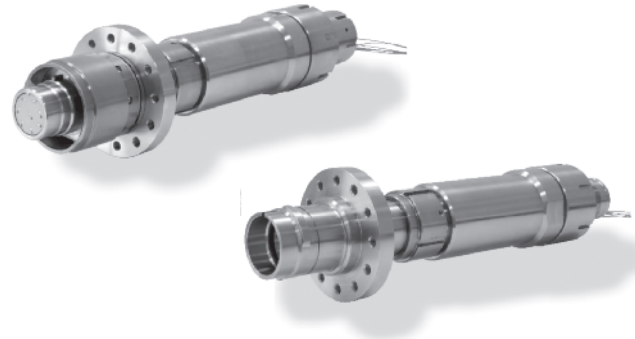

**D03000**

**Product Facts**

- Optical Subsea Wet Mateable
- ROV, Bulkhead, Stab plate and Diver versions
- Custom design available
- Back Reflection <-45dB
- Insertion loss <0.5dB
- 100 matings
- Single or Multimode fibers can be combined

D03000 is a high performing choice for optical applications requiring up to 12 channels and the ability to withstand operational water depths to 4500 m.

Optimized for Subsea Fiber Optic Distribution systems and connections to Subsea Trees.







Компания «ЭлектроПласт» предлагает заключение долгосрочных отношений при поставках импортных электронных компонентов на взаимовыгодных условиях!

Наши преимущества:

- Оперативные поставки широкого спектра электронных компонентов отечественного и импортного производства напрямую от производителей и с крупнейших мировых складов;
- Поставка более 17-ти миллионов наименований электронных компонентов;
- Поставка сложных, дефицитных, либо снятых с производства позиций;
- Оперативные сроки поставки под заказ (от 5 рабочих дней);
- Экспресс доставка в любую точку России;
- Техническая поддержка проекта, помощь в подборе аналогов, поставка прототипов;
- Система менеджмента качества сертифицирована по Международному стандарту ISO 9001;
- Лицензия ФСБ на осуществление работ с использованием сведений, составляющих государственную тайну;
- Поставка специализированных компонентов (Xilinx, Altera, Analog Devices, Intersil, Interpoint, Microsemi, Aeroflex, Peregrine, Syfer, Eurofarad, Texas Instrument, Miteq, Cobham, E2V, MA-COM, Hittite, Mini-Circuits, General Dynamics и др.);

Помимо этого, одним из направлений компании «ЭлектроПласт» является направление «Источники питания». Мы предлагаем Вам помощь Конструкторского отдела:

- Подбор оптимального решения, техническое обоснование при выборе компонента;
- Подбор аналогов;
- Консультации по применению компонента;
- Поставка образцов и прототипов;
- Техническая поддержка проекта;
- Защита от снятия компонента с производства.



#### Как с нами связаться

**Телефон:** 8 (812) 309 58 32 (многоканальный)

**Факс:** 8 (812) 320-02-42

**Электронная почта:** [org@eplast1.ru](mailto:org@eplast1.ru)

**Адрес:** 198099, г. Санкт-Петербург, ул. Калинина, дом 2, корпус 4, литера А.