

To our customers,

---

## Old Company Name in Catalogs and Other Documents

---

On April 1<sup>st</sup>, 2010, NEC Electronics Corporation merged with Renesas Technology Corporation, and Renesas Electronics Corporation took over all the business of both companies. Therefore, although the old company name remains in this document, it is a valid Renesas Electronics document. We appreciate your understanding.

Renesas Electronics website: <http://www.renesas.com>

April 1<sup>st</sup>, 2010  
Renesas Electronics Corporation

Issued by: Renesas Electronics Corporation (<http://www.renesas.com>)

Send any inquiries to <http://www.renesas.com/inquiry>.

## Notice

1. All information included in this document is current as of the date this document is issued. Such information, however, is subject to change without any prior notice. Before purchasing or using any Renesas Electronics products listed herein, please confirm the latest product information with a Renesas Electronics sales office. Also, please pay regular and careful attention to additional and different information to be disclosed by Renesas Electronics such as that disclosed through our website.
2. Renesas Electronics does not assume any liability for infringement of patents, copyrights, or other intellectual property rights of third parties by or arising from the use of Renesas Electronics products or technical information described in this document. No license, express, implied or otherwise, is granted hereby under any patents, copyrights or other intellectual property rights of Renesas Electronics or others.
3. You should not alter, modify, copy, or otherwise misappropriate any Renesas Electronics product, whether in whole or in part.
4. Descriptions of circuits, software and other related information in this document are provided only to illustrate the operation of semiconductor products and application examples. You are fully responsible for the incorporation of these circuits, software, and information in the design of your equipment. Renesas Electronics assumes no responsibility for any losses incurred by you or third parties arising from the use of these circuits, software, or information.
5. When exporting the products or technology described in this document, you should comply with the applicable export control laws and regulations and follow the procedures required by such laws and regulations. You should not use Renesas Electronics products or the technology described in this document for any purpose relating to military applications or use by the military, including but not limited to the development of weapons of mass destruction. Renesas Electronics products and technology may not be used for or incorporated into any products or systems whose manufacture, use, or sale is prohibited under any applicable domestic or foreign laws or regulations.
6. Renesas Electronics has used reasonable care in preparing the information included in this document, but Renesas Electronics does not warrant that such information is error free. Renesas Electronics assumes no liability whatsoever for any damages incurred by you resulting from errors in or omissions from the information included herein.
7. Renesas Electronics products are classified according to the following three quality grades: “Standard”, “High Quality”, and “Specific”. The recommended applications for each Renesas Electronics product depends on the product’s quality grade, as indicated below. You must check the quality grade of each Renesas Electronics product before using it in a particular application. You may not use any Renesas Electronics product for any application categorized as “Specific” without the prior written consent of Renesas Electronics. Further, you may not use any Renesas Electronics product for any application for which it is not intended without the prior written consent of Renesas Electronics. Renesas Electronics shall not be in any way liable for any damages or losses incurred by you or third parties arising from the use of any Renesas Electronics product for an application categorized as “Specific” or for which the product is not intended where you have failed to obtain the prior written consent of Renesas Electronics. The quality grade of each Renesas Electronics product is “Standard” unless otherwise expressly specified in a Renesas Electronics data sheets or data books, etc.
  - “Standard”: Computers; office equipment; communications equipment; test and measurement equipment; audio and visual equipment; home electronic appliances; machine tools; personal electronic equipment; and industrial robots.
  - “High Quality”: Transportation equipment (automobiles, trains, ships, etc.); traffic control systems; anti-disaster systems; anti-crime systems; safety equipment; and medical equipment not specifically designed for life support.
  - “Specific”: Aircraft; aerospace equipment; submersible repeaters; nuclear reactor control systems; medical equipment or systems for life support (e.g. artificial life support devices or systems), surgical implantations, or healthcare intervention (e.g. excision, etc.), and any other applications or purposes that pose a direct threat to human life.
8. You should use the Renesas Electronics products described in this document within the range specified by Renesas Electronics, especially with respect to the maximum rating, operating supply voltage range, movement power voltage range, heat radiation characteristics, installation and other product characteristics. Renesas Electronics shall have no liability for malfunctions or damages arising out of the use of Renesas Electronics products beyond such specified ranges.
9. Although Renesas Electronics endeavors to improve the quality and reliability of its products, semiconductor products have specific characteristics such as the occurrence of failure at a certain rate and malfunctions under certain use conditions. Further, Renesas Electronics products are not subject to radiation resistance design. Please be sure to implement safety measures to guard them against the possibility of physical injury, and injury or damage caused by fire in the event of the failure of a Renesas Electronics product, such as safety design for hardware and software including but not limited to redundancy, fire control and malfunction prevention, appropriate treatment for aging degradation or any other appropriate measures. Because the evaluation of microcomputer software alone is very difficult, please evaluate the safety of the final products or system manufactured by you.
10. Please contact a Renesas Electronics sales office for details as to environmental matters such as the environmental compatibility of each Renesas Electronics product. Please use Renesas Electronics products in compliance with all applicable laws and regulations that regulate the inclusion or use of controlled substances, including without limitation, the EU RoHS Directive. Renesas Electronics assumes no liability for damages or losses occurring as a result of your noncompliance with applicable laws and regulations.
11. This document may not be reproduced or duplicated, in any form, in whole or in part, without prior written consent of Renesas Electronics.
12. Please contact a Renesas Electronics sales office if you have any questions regarding the information contained in this document or Renesas Electronics products, or if you have any other inquiries.

(Note 1) “Renesas Electronics” as used in this document means Renesas Electronics Corporation and also includes its majority-owned subsidiaries.

(Note 2) “Renesas Electronics product(s)” means any product developed or manufactured by or for Renesas Electronics.

## 1. Overview

This MCU is built using the high-performance silicon gate CMOS process using a R8C/Tiny Series CPU core and is packaged in a 32-pin plastic molded LQFP. This MCU operates using sophisticated instructions featuring a high level of instruction efficiency. With 1M bytes of address space, it is capable of executing instructions at high speed.

The data flash ROM (2 KB X 2 blocks) is embedded.

### 1.1 Applications

Electric household appliance, office equipment, housing equipment (sensor, security), general industrial equipment, audio, etc.

## 1.2 Performance Overview

Table 1.1. lists the performance outline of this MCU.

**Table 1.1 Performance outline**

	Item	Performance
CPU	Number of basic instructions	89 instructions
	Minimum instruction execution time	50 ns ( $f(X_{IN}) = 20$ MHz, $V_{CC} = 3.0$ to 5.5 V) 100 ns ( $f(X_{IN}) = 10$ MHz, $V_{CC} = 2.7$ to 5.5 V)
	Operating mode	Single-chip
	Address space	1M bytes
	Memory capacity	See Table 1.2.
Peripheral function	Port	Input/Output: 22 (including LED drive port), Input: 2
	LED drive port	I/O port: 8
	Timer	Timer X: 8 bits x 1 channel, Timer Y: 8 bits x 1 channel, Timer Z: 8 bits x 1 channel (Each timer equipped with 8-bit prescaler) Timer C: 16 bits x 1 channel (Circuits of input capture and output compare)
	Serial interface	•1 channel Clock synchronous, UART •1 channel UART
	A/D converter	10-bit A/D converter: 1 circuit, 12 channels
	Watchdog timer	15 bits x 1 (with prescaler) Reset start function selectable
	Interrupt	Internal: 11 factors, External: 5 factors, Software: 4 factors, Priority level: 7 levels
	Clock generation circuit	2 circuits •Main clock generation circuit (Equipped with a built-in feedback resistor) •On-chip oscillator (high-speed, low-speed) On high-speed on-chip oscillator the frequency adjustment function is usable.
	Oscillation stop detection function	Main clock oscillation stop detection function
	Voltage detection circuit	Included
	Power on reset circuit	Included
Electrical characteristics	Supply voltage	$V_{CC} = 3.0$ to 5.5V ( $f(X_{IN}) = 20$ MHz) $V_{CC} = 2.7$ to 5.5V ( $f(X_{IN}) = 10$ MHz)
	Power consumption	Typ.9 mA ( $V_{CC} = 5.0$ V, ( $f(X_{IN}) = 20$ MHz) Typ.5 mA ( $V_{CC} = 3.0$ V, ( $f(X_{IN}) = 10$ MHz) Typ.35 $\mu$ A ( $V_{CC} = 3.0$ V, Wait mode, Peripheral clock stops) Typ.0.7 $\mu$ A ( $V_{CC} = 3.0$ V, Stop mode)
Flash memory	Program/erase supply voltage	$V_{CC} = 2.7$ to 5.5 V
	Program/erase endurance	10,000 times (Data flash) 1,000 times (Program ROM)
Operating ambient temperature		-20 to 85°C -40 to 85°C (D-version)
Package		32-pin plastic mold LQFP

### 1.3 Block Diagram

Figure 1.1 shows this MCU block diagram.

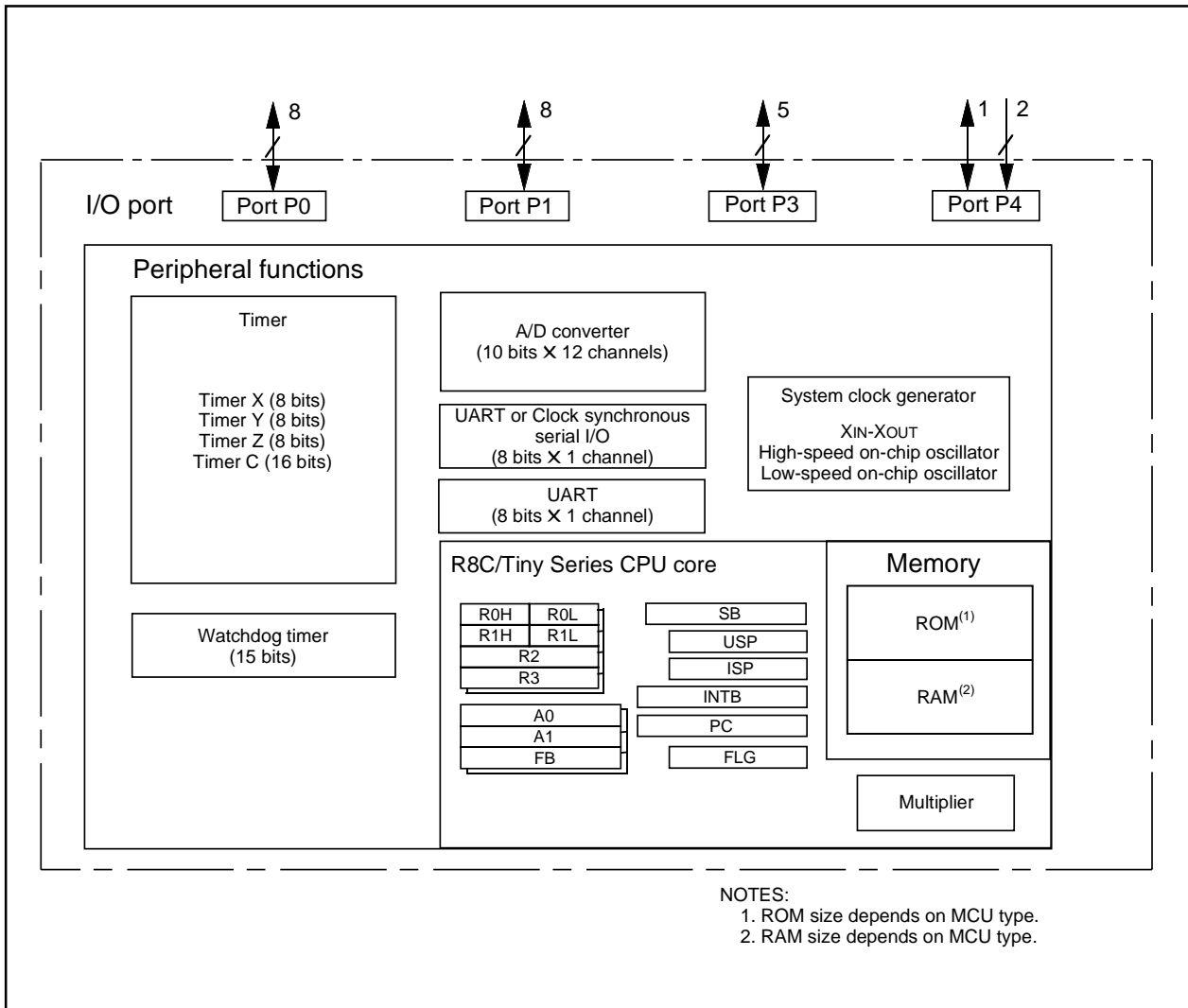

Figure 1.1 Block Diagram

### 1.4 Product Information

Table 1.2 lists the product information.

**Table 1.2 Product Information**

As of January 2006

Type No.	ROM capacity		RAM capacity	Package type	Remarks
	Program ROM	Data flash			
R5F21132FP	8K bytes	2K bytes x 2	512 bytes	PLQP0032GB-A	Flash memory version
R5F21133FP	12K bytes	2K bytes x 2	768 bytes	PLQP0032GB-A	
R5F21134FP	16K bytes	2K bytes x 2	1K bytes	PLQP0032GB-A	
R5F21132DFP	8K bytes	2K bytes x 2	512 bytes	PLQP0032GB-A	D version
R5F21133DFP	12K bytes	2K bytes x 2	768 bytes	PLQP0032GB-A	
R5F21134DFP	16K bytes	2K bytes x 2	1K bytes	PLQP0032GB-A	

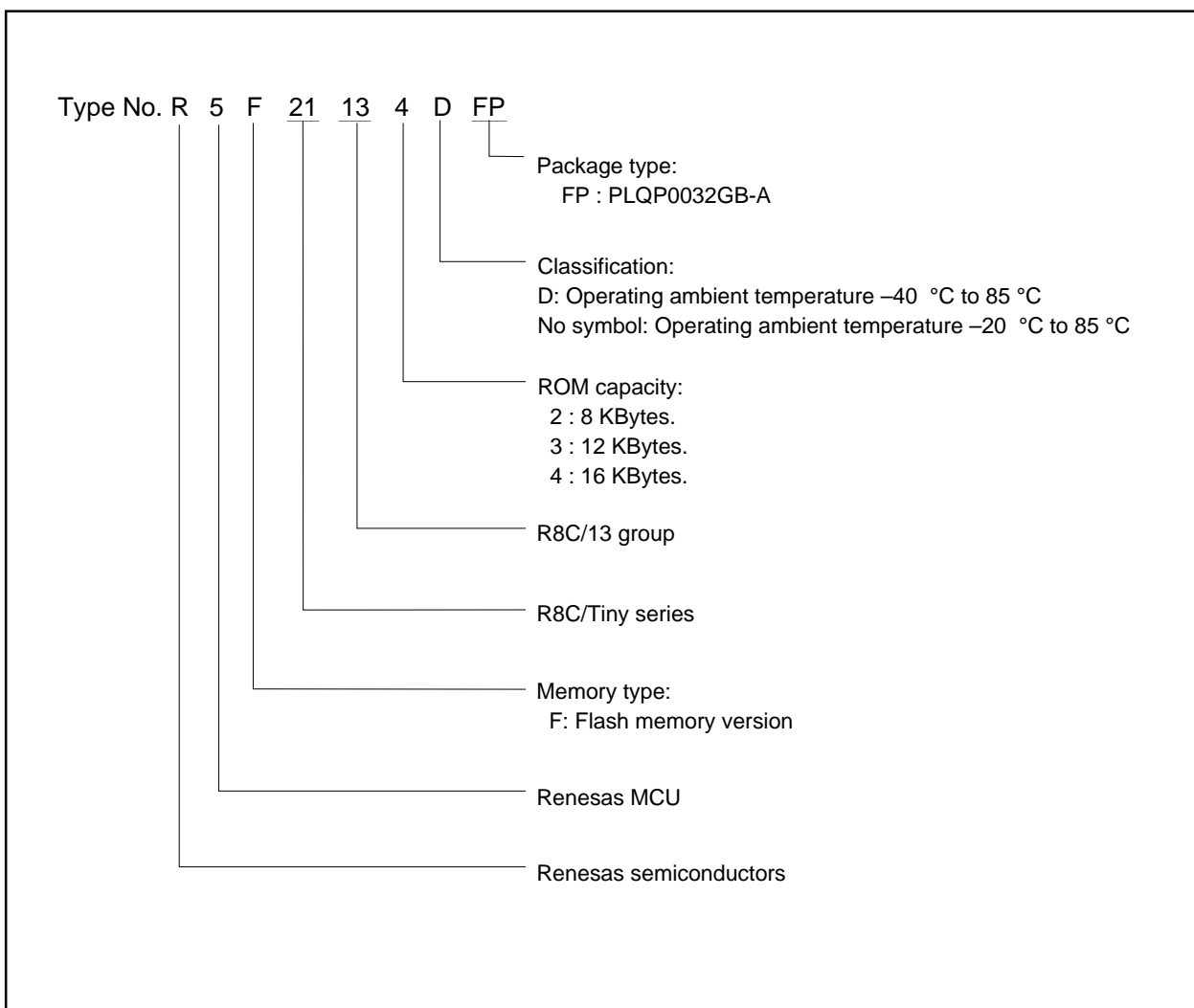

**Figure 1.2 Type No., Memory Size, and Package**

### 1.5 Pin Assignments

Figure 1.3 shows the pin configuration (top view).

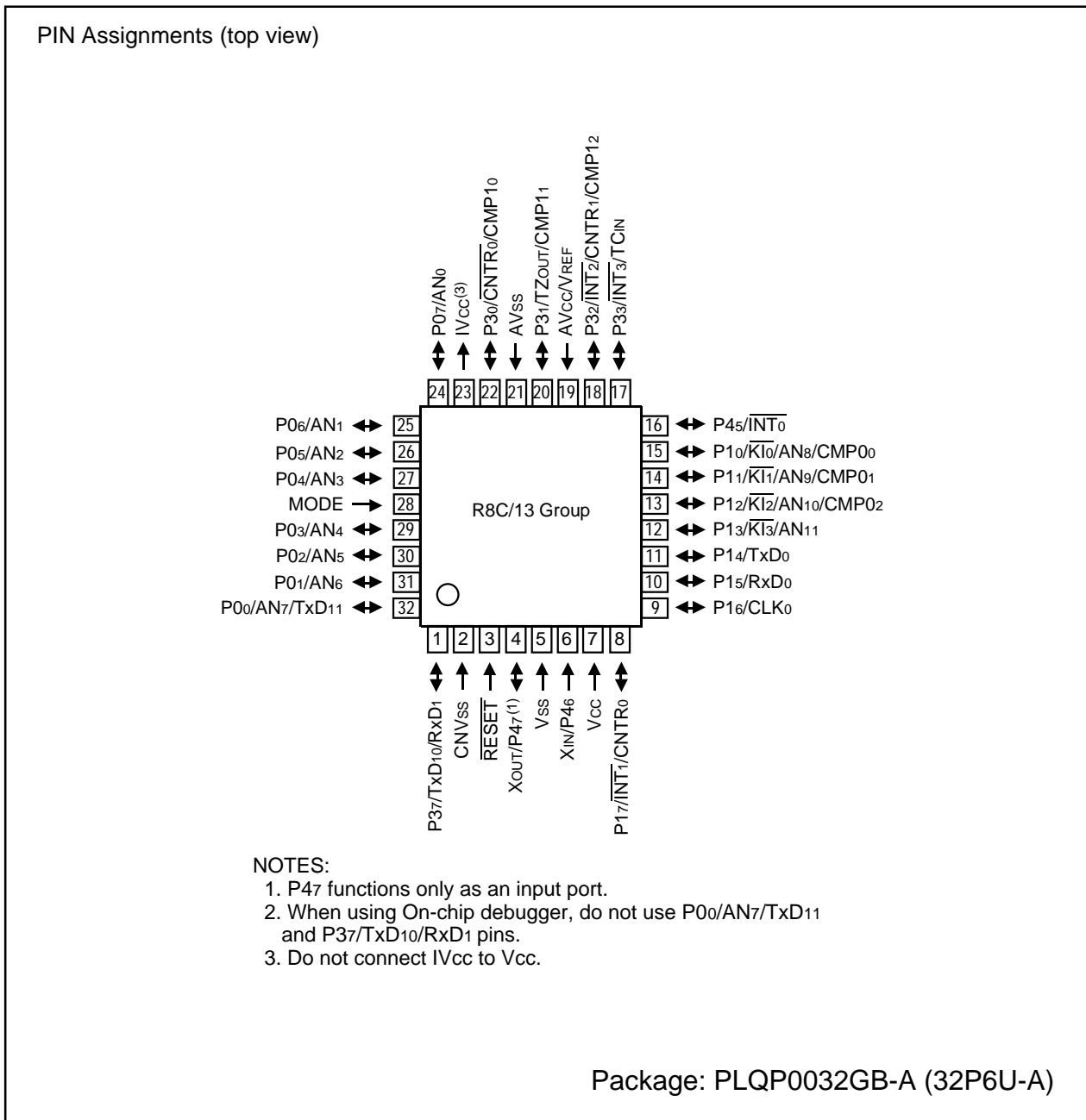

Figure 1.3 Pin Assignments (Top View)

## 1.6 Pin Description

Table 1.3 shows the pin description

**Table 1.3 Pin description**

Signal name	Pin name	I/O type	Function
Power supply input	Vcc, Vss	I	Apply 2.7 V to 5.5 V to the Vcc pin. Apply 0 V to the Vss pin.
IVcc	IVcc	O	This pin is to stabilize internal power supply. Connect this pin to Vss via a capacitor (0.1 $\mu$ F). Do not connect to Vcc.
Analog power supply input	AVcc, AVss	I	Power supply input pins for A/D converter. Connect the AVcc pin to Vcc. Connect the AVss pin to Vss. Connect a capacitor between pins AVcc and AVss.
Reset input	RESET	I	Input "L" on this pin resets the MCU.
CNVss	CNVss	I	Connect this pin to Vss via a resistor.
MODE	MODE	I	Connect this pin to Vcc via a resistor.
Main clock input	XIN	I	These pins are provided for the main clock generating circuit I/O. Connect a ceramic resonator or a crystal oscillator between the XIN and XOUT pins. To use an externally derived clock, input it to the XIN pin and leave the XOUT pin open.
Main clock output	XOUT	O	
INT interrupt input	INT0 to INT3	I	INT interrupt input pins.
Key input interrupt input	KI0 to KI3	I	Key input interrupt pins.
Timer X	CNTR0	I/O	Timer X I/O pin
	CNTR0	O	Timer X output pin
Timer Y	CNTR1	I/O	Timer Y I/O pin
Timer Z	TZOUT	O	Timer Z output pin
Timer C	TCIN	I	Timer C input pin
	CMP00 to CMP02, CMP10 to CMP12	O	The timer C output pins
Serial interface	CLK0	I/O	Transfer clock I/O pin.
	RxD0, RxD1	I	Serial data input pins.
	TxD0, TxD10, TxD11	O	Serial data output pins.
Reference voltage input	VREF	I	Reference voltage input pin for A/D converter. Connect the VREF pin to Vcc.
A/D converter	AN0 to AN11	I	Analog input pins for A/D converter
I/O port	P00 to P07, P10 to P17, P30 to P33, P37, P45	I/O	These are 8-bit CMOS I/O ports. Each port has an I/O select direction register, allowing each pin in that port to be directed for input or output individually. Any port set to input can select whether to use a pull-up resistor or not by program. P10 to P17 also function as LED drive ports.
Input port	P46, P47	I	Port for input-only



## 2. Central Processing Unit (CPU)

Figure 2.1 shows the CPU Register. The CPU contains 13 registers. Of these, R0, R1, R2, R3, A0, A1 and FB comprise a register bank. Two sets of register banks are provided.

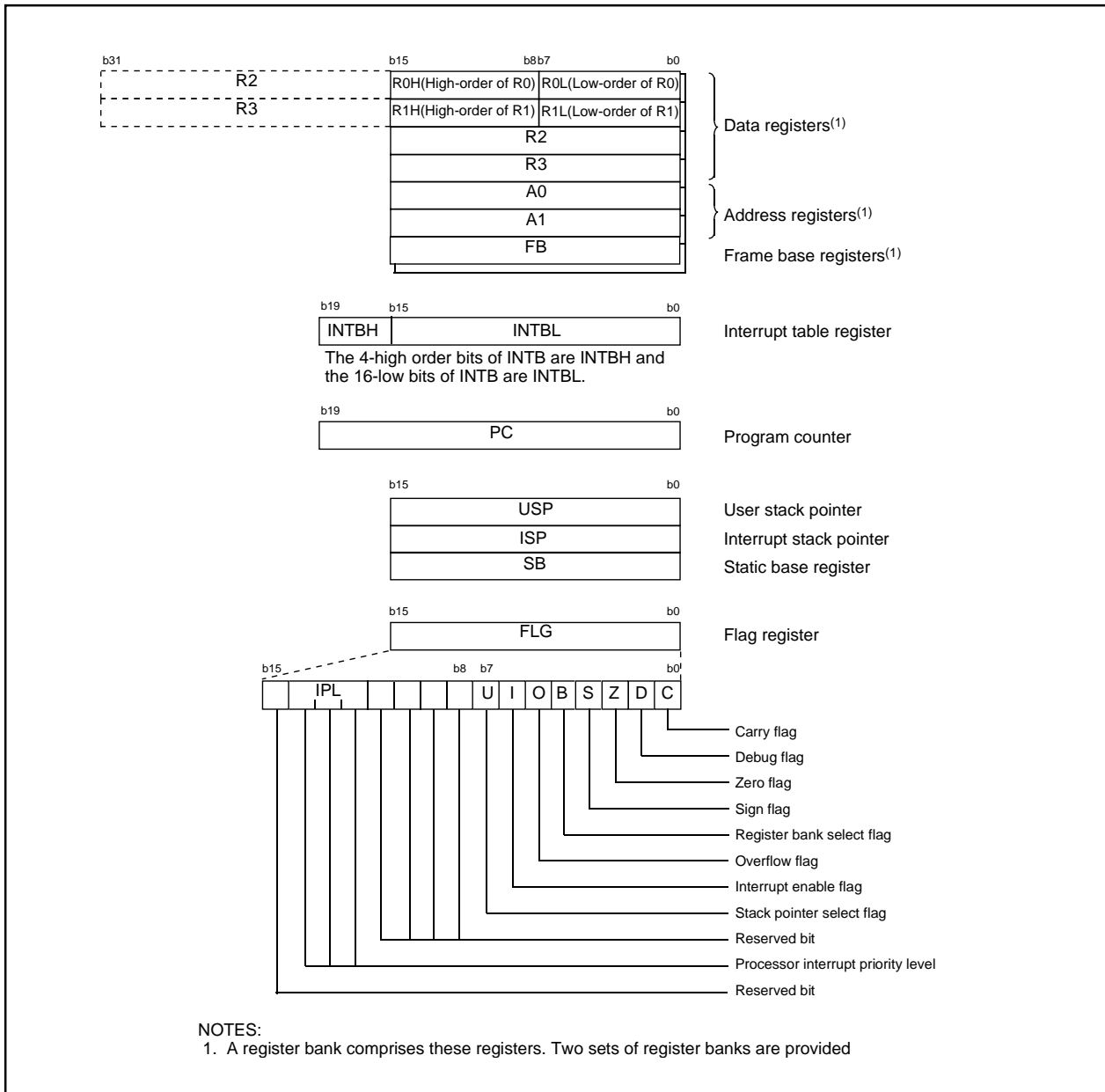

Figure 2.1 CPU Register

### 2.1 Data Registers (R0, R1, R2 and R3)

R0 is a 16-bit register for transfer, arithmetic and logic operations. The same applies to R1 to R3. The R0 can be split into high-order bit (R0H) and low-order bit (R0L) to be used separately as 8-bit data registers. The same applies to R1H and R1L as R0H and R0L. R2 can be combined with R0 to be used as a 32-bit data register (R2R0). The same applies to R3R1 as R2R0.

## 2.2 Address Registers (A0 and A1)

A0 is a 16-bit register for address register indirect addressing and address register relative addressing. They also are used for transfer, arithmetic and logic operations. The same applies to A1 as A0. A0 can be combined with A1 to be used as a 32-bit address register (A1A0).

## 2.3 Frame Base Register (FB)

FB is a 16-bit register for FB relative addressing.

## 2.4 Interrupt Table Register (INTB)

INTB is a 20-bit register indicates the start address of an interrupt vector table.

## 2.5 Program Counter (PC)

PC, 20 bits wide, indicates the address of an instruction to be executed.

## 2.6 User Stack Pointer (USP) and Interrupt Stack Pointer (ISP)

The stack pointer (SP), USP and ISP, are 16 bits wide each.

The U flag of FLG is used to switch between USP and ISP.

## 2.7 Static Base Register (SB)

SB is a 16-bit register for SB relative addressing.

## 2.8 Flag Register (FLG)

FLG is a 11-bit register indicating the CPU state.

### 2.8.1 Carry Flag (C)

The C flag retains a carry, borrow, or shift-out bit that has occurred in the arithmetic logic unit.

### 2.8.2 Debug Flag (D)

The D flag is for debug only. Set to "0".

### 2.8.3 Zero Flag (Z)

The Z flag is set to "1" when an arithmetic operation resulted in 0; otherwise, "0".

### 2.8.4 Sign Flag (S)

The S flag is set to "1" when an arithmetic operation resulted in a negative value; otherwise, "0".

### 2.8.5 Register Bank Select Flag (B)

The register bank 0 is selected when the B flag is "0". The register bank 1 is selected when this flag is set to "1".

### 2.8.6 Overflow Flag (O)

The O flag is set to "1" when the operation resulted in an overflow; otherwise, "0".

### 2.8.7 Interrupt Enable Flag (I)

The I flag enables a maskable interrupt.

An interrupt is disabled when the I flag is set to "0", and are enabled when the I flag is set to "1". The I flag is set to "0" when an interrupt request is acknowledged.

### 2.8.8 Stack Pointer Select Flag (U)

ISP is selected when the U flag is set to "0", USP is selected when the U flag is set to "1".

The U flag is set to "0" when a hardware interrupt request is acknowledged or the INT instruction of software interrupt numbers 0 to 31 is executed.

### 2.8.9 Processor Interrupt Priority Level (IPL)

IPL, 3 bits wide, assigns processor interrupt priority levels from level 0 to level 7.

If a requested interrupt has greater priority than IPL, the interrupt is enabled.

### 2.8.10 Reserved Bit

When write to this bit, set to "0". When read, its content is indeterminate.

### 3. Memory

Figure 3.1 is a memory map of this MCU. This MCU provides 1-Mbyte address space from addresses  $00000_{16}$  to  $FFFFFF_{16}$ .

The internal ROM (program ROM) is allocated lower addresses beginning with address  $0FFFF_{16}$ . For example, a 16-Kbyte internal ROM is allocated addresses from  $0C000_{16}$  to  $0FFFF_{16}$ .

The fixed interrupt vector table is allocated addresses  $0FFDC_{16}$  to  $0FFFF_{16}$ . They store the starting address of each interrupt routine.

The internal ROM (data flash) is allocated addresses from  $02000_{16}$  to  $02FFF_{16}$ .

The internal RAM is allocated higher addresses beginning with address  $00400_{16}$ . For example, a 1-Kbyte internal RAM is allocated addresses  $00400_{16}$  to  $007FF_{16}$ . The internal RAM is used not only for storing data, but for calling subroutines and stacks when interrupt request is acknowledged.

Special function registers (SFR) are allocated addresses  $00000_{16}$  to  $002FF_{16}$ . The peripheral function control registers are located there. All addresses, which have nothing allocated within the SFR, are reserved area and cannot be accessed by users.

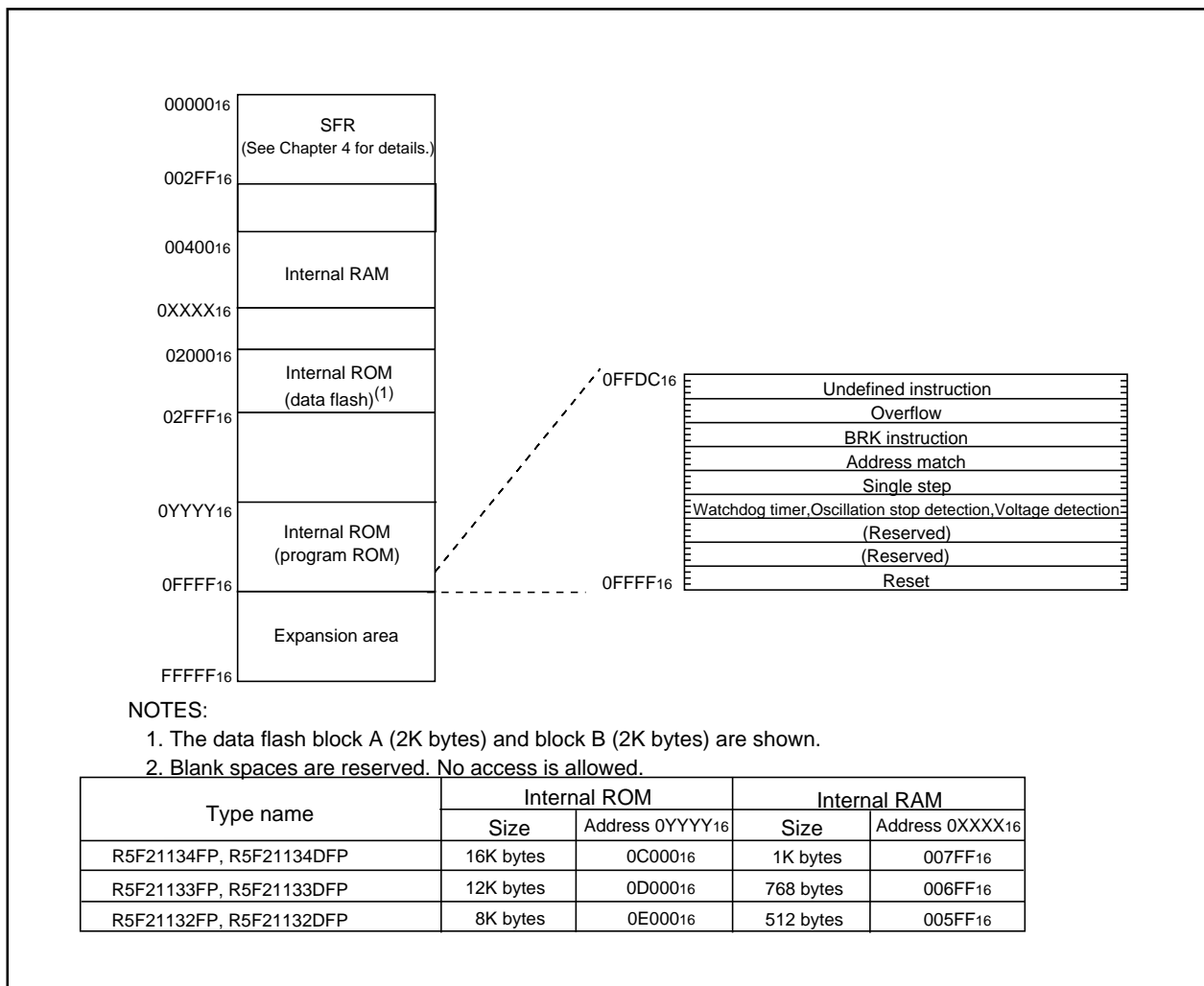

Figure 3.1 Memory Map

## 4. Special Function Register (SFR)

SFR(Special Function Register) is the control register of peripheral functions. Tables 4.1 to 4.4 list the SFR information

**Table 4.1 SFR Information(1)(1)**

Address	Register	Symbol	After reset
0000 <sub>16</sub>			
0001 <sub>16</sub>			
0002 <sub>16</sub>			
0003 <sub>16</sub>			
0004 <sub>16</sub>	Processor mode register 0 <sup>(1)</sup>	PM0	0016
0005 <sub>16</sub>	Processor mode register 1	PM1	0016
0006 <sub>16</sub>	System clock control register 0	CM0	011010002
0007 <sub>16</sub>	System clock control register 1	CM1	001000002
0008 <sub>16</sub>	High-speed on-chip oscillator control register 0	HR0	0016
0009 <sub>16</sub>	Address match interrupt enable register	AIER	XXXXXX002
000A <sub>16</sub>	Protect register	PRCR	00XXX0002
000B <sub>16</sub>	High-speed on-chip oscillator control register 1	HR1	4016
000C <sub>16</sub>	Oscillation stop detection register	OCD	000001002
000D <sub>16</sub>	Watchdog timer reset register	WDTR	XX16
000E <sub>16</sub>	Watchdog timer start register	WDTS	XX16
000F <sub>16</sub>	Watchdog timer control register	WDC	000111112
0010 <sub>16</sub>	Address match interrupt register 0	RMAD0	0016
0011 <sub>16</sub>			0016
0012 <sub>16</sub>			X016
0013 <sub>16</sub>			
0014 <sub>16</sub>	Address match interrupt register 1	RMAD1	0016
0015 <sub>16</sub>			0016
0016 <sub>16</sub>			X016
0017 <sub>16</sub>			
0018 <sub>16</sub>			
0019 <sub>16</sub>	Voltage detection register 1 <sup>(2)</sup>	VCR1	000010002
001A <sub>16</sub>	Voltage detection register 2 <sup>(2)</sup>	VCR2	0016 <sup>(3)</sup> 10000002 <sup>(4)</sup>
001B <sub>16</sub>			
001C <sub>16</sub>			
001D <sub>16</sub>			
001E <sub>16</sub>	INT0 input filter select register	INT0F	XXXXX0002
001F <sub>16</sub>	Voltage detection interrupt register <sup>(2)</sup>	D4INT	0016 <sup>(3)</sup> 010000012 <sup>(4)</sup>
0020 <sub>16</sub>			
0021 <sub>16</sub>			
0022 <sub>16</sub>			
0023 <sub>16</sub>			
0024 <sub>16</sub>			
0025 <sub>16</sub>			
0026 <sub>16</sub>			
0027 <sub>16</sub>			
0028 <sub>16</sub>			
0029 <sub>16</sub>			
002A <sub>16</sub>			
002B <sub>16</sub>			
002C <sub>16</sub>			
002D <sub>16</sub>			
002E <sub>16</sub>			
002F <sub>16</sub>			
0030 <sub>16</sub>			
0031 <sub>16</sub>			
0032 <sub>16</sub>			
0033 <sub>16</sub>			
0034 <sub>16</sub>			
0035 <sub>16</sub>			
0036 <sub>16</sub>			
0037 <sub>16</sub>			
0038 <sub>16</sub>			
0039 <sub>16</sub>			
003A <sub>16</sub>			
003B <sub>16</sub>			
003C <sub>16</sub>			
003D <sub>16</sub>			
003E <sub>16</sub>			
003F <sub>16</sub>			

X : Undefined

NOTES:

- Blank spaces are reserved. No access is allowed.
- Software reset or the watchdog timer reset does not affect this register.
- Owing to Reset input.
- In the case of RESET pin = H retaining.

Table 4.2 SFR Information(2)<sup>(1)</sup>

Address	Register	Symbol	After reset
0040 <sub>16</sub>			
0041 <sub>16</sub>			
0042 <sub>16</sub>			
0043 <sub>16</sub>			
0044 <sub>16</sub>			
0045 <sub>16</sub>			
0046 <sub>16</sub>			
0047 <sub>16</sub>			
0048 <sub>16</sub>			
0049 <sub>16</sub>			
004A <sub>16</sub>			
004B <sub>16</sub>			
004C <sub>16</sub>			
004D <sub>16</sub>	Key input interrupt control register	KUPIC	XXXXX0002
004E <sub>16</sub>	AD conversion interrupt control register	ADIC	XXXXX0002
004F <sub>16</sub>			
0050 <sub>16</sub>	Compare 1 interrupt control register	CMP1IC	XXXXX0002
0051 <sub>16</sub>	UART0 transmit interrupt control register	S0TIC	XXXXX0002
0052 <sub>16</sub>	UART0 receive interrupt control register	S0RIC	XXXXX0002
0053 <sub>16</sub>	UART1 transmit interrupt control register	S1TIC	XXXXX0002
0054 <sub>16</sub>	UART1 receive interrupt control register	S1RIC	XXXXX0002
0055 <sub>16</sub>	INT2 interrupt control register	INT2IC	XXXXX0002
0056 <sub>16</sub>	Timer X interrupt control register	TXIC	XXXXX0002
0057 <sub>16</sub>	Timer Y interrupt control register	TYIC	XXXXX0002
0058 <sub>16</sub>	Timer Z interrupt control register	TZIC	XXXXX0002
0059 <sub>16</sub>	INT1 interrupt control register	INT1IC	XXXXX0002
005A <sub>16</sub>	INT3 interrupt control register	INT3IC	XXXXX0002
005B <sub>16</sub>	Timer C interrupt control register	TCIC	XXXXX0002
005C <sub>16</sub>	Compare 0 interrupt control register	CMP0IC	XXXXX0002
005D <sub>16</sub>	INT0 interrupt control register	INT0IC	XX00X0002
005E <sub>16</sub>			
005F <sub>16</sub>			
0060 <sub>16</sub>			
0061 <sub>16</sub>			
0062 <sub>16</sub>			
0063 <sub>16</sub>			
0064 <sub>16</sub>			
0065 <sub>16</sub>			
0066 <sub>16</sub>			
0067 <sub>16</sub>			
0068 <sub>16</sub>			
0069 <sub>16</sub>			
006A <sub>16</sub>			
006B <sub>16</sub>			
006C <sub>16</sub>			
006D <sub>16</sub>			
006E <sub>16</sub>			
006F <sub>16</sub>			
0070 <sub>16</sub>			
0071 <sub>16</sub>			
0072 <sub>16</sub>			
0073 <sub>16</sub>			
0074 <sub>16</sub>			
0075 <sub>16</sub>			
0076 <sub>16</sub>			
0077 <sub>16</sub>			
0078 <sub>16</sub>			
0079 <sub>16</sub>			
007A <sub>16</sub>			
007B <sub>16</sub>			
007C <sub>16</sub>			
007D <sub>16</sub>			
007E <sub>16</sub>			
007F <sub>16</sub>			

X : Undefined

NOTES:

1. Blank spaces are reserved. No access is allowed.

Table 4.3 SFR Information(3)<sup>(1)</sup>

Address	Register	Symbol	After reset
0080 <sub>16</sub>	Timer Y, Z mode register	TYZMR	00 <sub>16</sub>
0081 <sub>16</sub>	Prescaler Y register	PREY	FF <sub>16</sub>
0082 <sub>16</sub>	Timer Y secondary register	TYSC	FF <sub>16</sub>
0083 <sub>16</sub>	Timer Y primary register	TYPR	FF <sub>16</sub>
0084 <sub>16</sub>	Timer Y, Z waveform output control register	PUM	00 <sub>16</sub>
0085 <sub>16</sub>	Prescaler Z register	PREZ	FF <sub>16</sub>
0086 <sub>16</sub>	Timer Z secondary register	TZSC	FF <sub>16</sub>
0087 <sub>16</sub>	Timer Z primary register	TZPR	FF <sub>16</sub>
0088 <sub>16</sub>			
0089 <sub>16</sub>			
008A <sub>16</sub>	Timer Y, Z output control register	TYZOC	00 <sub>16</sub>
008B <sub>16</sub>	Timer X mode register	TXMR	00 <sub>16</sub>
008C <sub>16</sub>	Prescaler X register	PREX	FF <sub>16</sub>
008D <sub>16</sub>	Timer X register	TX	FF <sub>16</sub>
008E <sub>16</sub>	Count source set register	TCSS	00 <sub>16</sub>
008F <sub>16</sub>			
0090 <sub>16</sub>	Timer C register	TC	00 <sub>16</sub>
0091 <sub>16</sub>			00 <sub>16</sub>
0092 <sub>16</sub>			
0093 <sub>16</sub>			
0094 <sub>16</sub>			
0095 <sub>16</sub>			
0096 <sub>16</sub>	External input enable register	INTEN	00 <sub>16</sub>
0097 <sub>16</sub>			
0098 <sub>16</sub>	Key input enable register	KIEN	00 <sub>16</sub>
0099 <sub>16</sub>			
009A <sub>16</sub>	Timer C control register 0	TCC0	00 <sub>16</sub>
009B <sub>16</sub>	Timer C control register 1	TCC1	00 <sub>16</sub>
009C <sub>16</sub>	Capture, compare 0 register	TM0	00 <sub>16</sub>
009D <sub>16</sub>			00 <sub>16</sub> <sup>(2)</sup>
009E <sub>16</sub>	Compare 1 register	TM1	FF <sub>16</sub>
009F <sub>16</sub>			FF <sub>16</sub>
00A0 <sub>16</sub>	UART0 transmit/receive mode register	U0MR	00 <sub>16</sub>
00A1 <sub>16</sub>	UART0 bit rate register	U0BRG	XX <sub>16</sub>
00A2 <sub>16</sub>	UART0 transmit buffer register	U0TB	XX <sub>16</sub>
00A3 <sub>16</sub>			XX <sub>16</sub>
00A4 <sub>16</sub>	UART0 transmit/receive control register 0	U0C0	00001000 <sub>2</sub>
00A5 <sub>16</sub>	UART0 transmit/receive control register 1	U0C1	00000010 <sub>2</sub>
00A6 <sub>16</sub>	UART0 receive buffer register	U0RB	XX <sub>16</sub>
00A7 <sub>16</sub>			XX <sub>16</sub>
00A8 <sub>16</sub>	UART1 transmit/receive mode register	U1MR	00 <sub>16</sub>
00A9 <sub>16</sub>	UART1 bit rate register	U1BRG	XX <sub>16</sub>
00AA <sub>16</sub>	UART1 transmit buffer register	U1TB	XX <sub>16</sub>
00AB <sub>16</sub>			XX <sub>16</sub>
00AC <sub>16</sub>	UART1 transmit/receive control register 0	U1C0	00001000 <sub>2</sub>
00AD <sub>16</sub>	UART1 transmit/receive control register 1	U1C1	00000010 <sub>2</sub>
00AE <sub>16</sub>	UART1 receive buffer register	U1RB	XX <sub>16</sub>
00AF <sub>16</sub>			XX <sub>16</sub>
00B0 <sub>16</sub>	UART transmit/receive control register 2	UCON	00 <sub>16</sub>
00B1 <sub>16</sub>			
00B2 <sub>16</sub>			
00B3 <sub>16</sub>			
00B4 <sub>16</sub>			
00B5 <sub>16</sub>			
00B6 <sub>16</sub>			
00B7 <sub>16</sub>			
00B8 <sub>16</sub>			
00B9 <sub>16</sub>			
00BA <sub>16</sub>			
00BB <sub>16</sub>			
00BC <sub>16</sub>			
00BD <sub>16</sub>			
00BE <sub>16</sub>			
00BF <sub>16</sub>			

X : Undefined

## NOTES:

- Blank spaces are reserved. No access is allowed.
- When output compare mode (the TCC13 bit in the TCC1 register = 1) is selected, the value after reset is set to "FFFF<sub>16</sub>".

Table 4.4 SFR Information(4)(1)

Address	Register	Symbol	After reset
00C0 <sub>16</sub> 00C1 <sub>16</sub>	AD register	AD	XX16 XX16
00C2 <sub>16</sub>			
00C3 <sub>16</sub>			
00C4 <sub>16</sub>			
00C5 <sub>16</sub>			
00C6 <sub>16</sub>			
00C7 <sub>16</sub>			
00C8 <sub>16</sub>			
00C9 <sub>16</sub>			
00CA <sub>16</sub>			
00CB <sub>16</sub>			
00CC <sub>16</sub>			
00CD <sub>16</sub>			
00CE <sub>16</sub>			
00CF <sub>16</sub>			
00D0 <sub>16</sub>			
00D1 <sub>16</sub>			
00D2 <sub>16</sub>			
00D3 <sub>16</sub>			
00D4 <sub>16</sub>	AD control register 2	ADCON2	0016
00D5 <sub>16</sub>			
00D6 <sub>16</sub>	AD control register 0	ADCON0	00000XXX2
00D7 <sub>16</sub>	AD control register 1	ADCON1	0016
00D8 <sub>16</sub>			
00D9 <sub>16</sub>			
00DA <sub>16</sub>			
00DB <sub>16</sub>			
00DC <sub>16</sub>			
00DD <sub>16</sub>			
00DE <sub>16</sub>			
00DF <sub>16</sub>			
00E0 <sub>16</sub>	Port P0 register	P0	XX16
00E1 <sub>16</sub>	Port P1 register	P1	XX16
00E2 <sub>16</sub>	Port P0 direction register	PD0	0016
00E3 <sub>16</sub>	Port P1 direction register	PD1	0016
00E4 <sub>16</sub>			
00E5 <sub>16</sub>	Port P3 register	P3	XX16
00E6 <sub>16</sub>			
00E7 <sub>16</sub>	Port P3 direction register	PD3	0016
00E8 <sub>16</sub>	Port P4 register	P4	XX16
00E9 <sub>16</sub>			
00EA <sub>16</sub>	Port P4 direction register	PD4	0016
00EB <sub>16</sub>			
00EC <sub>16</sub>			
00ED <sub>16</sub>			
00EE <sub>16</sub>			
00EF <sub>16</sub>			
00F0 <sub>16</sub>			
00F1 <sub>16</sub>			
00F2 <sub>16</sub>			
00F3 <sub>16</sub>			
00F4 <sub>16</sub>			
00F5 <sub>16</sub>			
00F6 <sub>16</sub>			
00F7 <sub>16</sub>			
00F8 <sub>16</sub>			
00F9 <sub>16</sub>			
03FA <sub>16</sub>			
00FB <sub>16</sub>			
00FC <sub>16</sub>	Pull-up control register 0	PUR0	00XX00002
00FD <sub>16</sub>	Pull-up control register 1	PUR1	XXXXXX0X2
00FE <sub>16</sub>	Port P1 drive capacity control register	DRR	0016
00FF <sub>16</sub>	Timer C output control register	TCOUT	0016
01B3 <sub>16</sub>	Flash memory control register 4	FMR4	010000002
01B4 <sub>16</sub>			
01B5 <sub>16</sub>	Flash memory control register 1	FMR1	1000000X2
01B6 <sub>16</sub>			
01B7 <sub>16</sub>	Flash memory control register 0	FMR0	000000012
0FFF <sub>16</sub>	Option function select register <sup>(2)</sup>	OFS	(Note 2)

X : Undefined

## NOTES:

- Blank columns, 0100<sub>16</sub> to 01B2<sub>16</sub> and 01B8<sub>16</sub> to 02FF<sub>16</sub> are all reserved. No access is allowed.
- The watchdog timer control bit is assigned. Refer to "Figure11.2 OFS, WDC, WDTR and WDTS registers" of Hardware Manual for details

## 5. Electrical Characteristics

**Table 5.1 Absolute Maximum Ratings**

Symbol	Parameter	Condition	Rated value	Unit
V <sub>CC</sub>	Supply voltage	V <sub>CC</sub> =AV <sub>CC</sub>	-0.3 to 6.5	V
AV <sub>CC</sub>	Analog supply voltage	V <sub>CC</sub> =AV <sub>CC</sub>	-0.3 to 6.5	V
V <sub>I</sub>	Input voltage		-0.3 to V <sub>CC</sub> +0.3	V
V <sub>O</sub>	Output voltage		-0.3 to V <sub>CC</sub> +0.3	V
P <sub>d</sub>	Power dissipation	T <sub>opr</sub> =25 °C	300	mW
T <sub>opr</sub>	Operating ambient temperature		-20 to 85 / -40 to 85 (D version)	°C
T <sub>stg</sub>	Storage temperature		-65 to 150	°C

**Table 5.2 Recommended Operating Conditions**

Symbol	Parameter	Conditions	Standard			Unit	
			Min.	Typ.	Max.		
V <sub>CC</sub>	Supply voltage		2.7	—	5.5	V	
AV <sub>CC</sub>	Analog supply voltage		—	V <sub>CC</sub> (3)	—	V	
V <sub>SS</sub>	Supply voltage		—	0	—	V	
AV <sub>SS</sub>	Analog supply voltage		—	0	—	V	
V <sub>IH</sub>	"H" input voltage		0.8V <sub>CC</sub>	—	V <sub>CC</sub>	V	
V <sub>IL</sub>	"L" input voltage		0	—	0.2V <sub>CC</sub>	V	
I <sub>OH</sub> (sum)	"H" peak all output currents	Sum of all pins' IOH (peak)	—	—	-60.0	mA	
I <sub>OH</sub> (peak)	"H" peak output current		—	—	-10.0	mA	
I <sub>OH</sub> (avg)	"H" average output current		—	—	-5.0	mA	
I <sub>OL</sub> (sum)	"L" peak all output currents	Sum of all pins' IOL (peak)	—	—	60	mA	
I <sub>OL</sub> (peak)	"L" peak output current	Except P10 to P17	—	—	10	mA	
		P10 to P17	Drive ability HIGH	—	—	30	mA
			Drive ability LOW	—	—	10	mA
I <sub>OL</sub> (avg)	"L" average output current	Except P10 to P17	—	—	5	mA	
		P10 to P17	Drive ability HIGH	—	—	15	mA
			Drive ability LOW	—	—	5	mA
f (XIN)	Main clock input oscillation frequency	3.0V ≤ V <sub>CC</sub> ≤ 5.5V	0	—	20	MHz	
		2.7V ≤ V <sub>CC</sub> < 3.0V	0	—	10	MHz	

**NOTES:**

- V<sub>CC</sub> = AV<sub>CC</sub> = 2.7 to 5.5V at T<sub>opr</sub> = -20 to 85 °C / -40 to 85 °C, unless otherwise specified.
- The typical values when average output current is 100ms.
- Hold V<sub>CC</sub>=AV<sub>CC</sub>.

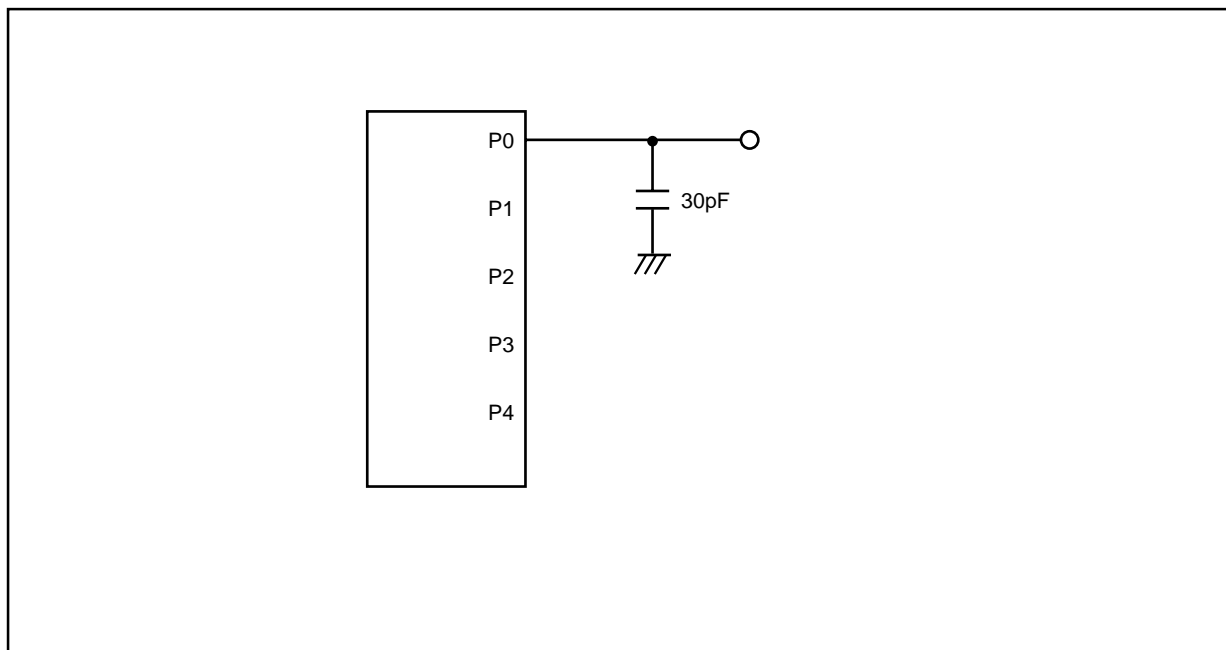

**Table 5.3 A/D Conversion Characteristics**

Symbol	Parameter		Measuring condition	Standard			Unit
				Min.	Typ.	Max.	
—	Resolution		$V_{ref} = V_{CC}$	—	—	10	Bit
—	Absolute accuracy	10 bit mode	$\phi_{AD}=10\text{ MHz}$ , $V_{ref}=V_{CC}=5.0\text{V}$	—	—	$\pm 3$	LSB
		8 bit mode	$\phi_{AD}=10\text{ MHz}$ , $V_{ref}=V_{CC}=5.0\text{V}$	—	—	$\pm 2$	LSB
		10 bit mode	$\phi_{AD}=10\text{ MHz}$ , $V_{ref}=V_{CC}=3.3\text{V}^{(3)}$	—	—	$\pm 5$	LSB
		8 bit mode	$\phi_{AD}=10\text{ MHz}$ , $V_{ref}=V_{CC}=3.3\text{V}^{(3)}$	—	—	$\pm 2$	LSB
$R_{LADDER}$	Ladder resistance		$V_{REF}=V_{CC}$	10	—	40	$k\Omega$
$t_{CONV}$	Conversion time	10 bit mode	$\phi_{AD}=10\text{ MHz}$ , $V_{ref}=V_{CC}=5.0\text{V}$	3.3	—	—	$\mu\text{s}$
		8 bit mode	$\phi_{AD}=10\text{ MHz}$ , $V_{ref}=V_{CC}=5.0\text{V}$	2.8	—	—	$\mu\text{s}$
$V_{REF}$	Reference voltage			—	$V_{CC}^{(4)}$	—	V
$V_{IA}$	Analog input voltage			0	—	$V_{ref}$	V
—	A/D operating clock frequency <sup>(2)</sup>	Without sample & hold		0.25	—	10	MHz
		With sample & hold		1.0	—	10	MHz

## NOTES:

1.  $V_{CC}=AV_{CC}=2.7$  to  $5.5\text{V}$  at  $T_{opr} = -20$  to  $85\text{ }^\circ\text{C}$  /  $-40$  to  $85\text{ }^\circ\text{C}$ , unless otherwise specified.
2. If  $f_{AD}$  exceeds 10 MHz more, divide the  $f_{AD}$  and hold A/D operating clock frequency ( $\phi_{AD}$ ) 10 MHz or below.
3. If the  $AV_{CC}$  is less than 4.2V, divide the  $f_{AD}$  and hold A/D operating clock frequency ( $\phi_{AD}$ )  $f_{AD}/2$  or below.
4. Hold  $V_{CC}=V_{ref}$ .

**Figure 5.1 Port P0 to P4 measurement circuit**

**Table 5.4 Flash Memory (Program ROM) Electrical Characteristics**

Symbol	Parameter	Measuring condition	Standard			Unit
			Min.	Typ.	Max	
—	Program/Erase endurance <sup>(2)</sup>		1000 <sup>(3)</sup>	—	—	times
—	Byte program time		—	50	—	μs
—	Block erase time		—	0.4	—	s
t <sub>d</sub> (SR-ES)	Time delay from Suspend Request until Erase Suspend		—	—	8	ms
—	Erase Suspend Request Interval		10	—	—	ms
—	Program, Erase Voltage		2.7	—	5.5	V
—	Read Voltage		2.7	—	5.5	V
—	Program, Erase Temperature		0	—	60	°C
—	Data hold time <sup>(7)</sup>	Ambient temperature = 55 °C	20	—	—	year

**NOTES:**

1. Referenced to V<sub>CC</sub>=A<sub>V</sub>cc=2.7 to 5.5V at Topr = 0°C to 60°C unless otherwise specified.
2. Definition of Program/Erase  
The endurance of Program/Erase shows a time for each block.  
If the program/erase number is “n” (n = 1000, 10000), “n” times erase can be performed for each block.  
For example, if performing one-byte write to the distinct addresses on Block A of 2K-byte block 2048 times and then erasing that block, the number of Program/Erase cycles is one time.  
However, performing multiple writes to the same address before an erase operation is prohibited (overwriting prohibited).
3. Numbers of Program/Erase cycles for which all electrical characteristics is guaranteed.
4. To reduce the number of Program/Erase cycles, a block erase should ideally be performed after writing in series as many distinct addresses (only one time each) as possible. If programming a set of 16 bytes, write up to 128 sets and then erase them one time. This will result in ideally reducing the number of Program/Erase cycles. Additionally, averaging the number of Program/Erase cycles for Block A and B will be more effective. It is important to track the total number of block erases and restrict the number.
5. If error occurs during block erase, attempt to execute the clear status register command, then the block erase command at least three times until the erase error disappears.
6. Customers desiring Program/Erase failure rate information should contact their Renesas technical support representative.
7. The data hold time includes time that the power supply is off or the clock is not supplied.

**Table 5.5 Flash Memory (Data flash Block A, Block B) Electrical Characteristics<sup>(4)</sup>**

Symbol	Parameter	Measuring condition	Standard			Unit
			Min.	Typ.	Max	
—	Program/Erase endurance <sup>(2)</sup>		10000 <sup>(3)</sup>	—	—	times
—	Byte program time(program/erase endurance ≤1000 times)		—	50	400	μs
—	Byte program time(program/erase endurance >1000 times)		—	65	—	μs
—	Block erase time(program/erase endurance ≤1000 times)		—	0.2	9	s
—	Block erase time(program/erase endurance >1000 times)		—	0.3	—	s
t <sub>d</sub> (SR-ES)	Time delay from Suspend Request until Erase Suspend		—	—	8	ms
—	Erase Suspend Request Interval		10	—	—	ms
—	Program, Erase Voltage		2.7	—	5.5	V
—	Read Voltage		2.7	—	5.5	V
—	Program/Erase Temperature		-20(-40) <sup>(8)</sup>	—	85	°C
—	Data hold time <sup>(9)</sup>	Ambient temperature = 55 °C	20	—	—	year

## NOTES:

1. Referenced to V<sub>CC</sub>=AV<sub>CC</sub>=2.7 to 5.5V at Topr = -20°C to 85°C / -40°C to 85°C unless otherwise specified.
2. Definition of Program/Erase  
The endurance of Program/Erase shows a time for each block.  
If the program/erase number is “n” (n = 1000, 10000), “n” times erase can be performed for each block.  
For example, if performing one-byte write to the distinct addresses on Block A of 2K-byte block 2048 times and then erasing that block, the number of Program/Erase cycles is one time.  
However, performing multiple writes to the same address before an erase operation is prohibited (overwriting prohibited).
3. Numbers of Program/Erase cycles for which all electrical characteristics is guaranteed.
4. Table 5.5 applies for Block A or B when the Program/Erase cycles are more than 1000. The byte program time up to 1000 cycles are the same as that of the program area (see Table 5.4).
5. To reduce the number of Program/Erase cycles, a block erase should ideally be performed after writing in series as many distinct addresses (only one time each) as possible. If programming a set of 16 bytes, write up to 128 sets and then erase them one time. This will result in ideally reducing the number of Program/Erase cycles. Additionally, averaging the number of Program/Erase cycles for Block A and B will be more effective. It is important to track the total number of block erases and restrict the number.
6. If error occurs during block erase, attempt to execute the clear status register command, then the block erase command at least three times until the erase error disappears.
7. Customers desiring Program/Erase failure rate information should contact their Renesas technical support representative.
8. -40 °C for D version.
9. The data hold time includes time that the power supply is off or the clock is not supplied.

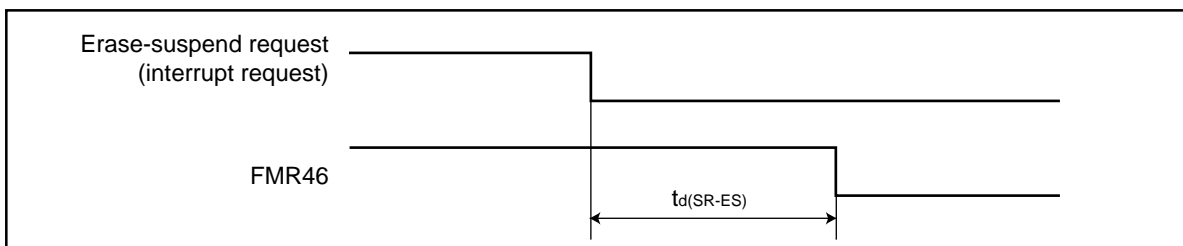
**Figure 5.2 Time delay from Suspend Request until Erase Suspend**

**Table 5.6 Voltage Detection Circuit Electrical Characteristics**

Symbol	Parameter	Measuring condition	Standard			Unit
			Min.	Typ.	Max.	
Vdet	Voltage detection level		3.3	3.8	4.3	V
	Voltage detection interrupt request generating time <sup>(2)</sup>			40		μs
	Voltage detection circuit self consumption current	VC27=1, VCC=5.0V		600		nA
td(E-A)	Waiting time until voltage detection circuit operation starts <sup>(3)</sup>				20	μs
Vccmin	Microcomputer operation voltage minimum value		2.7			V

## NOTES:

1. The measuring condition is  $V_{CC}=AV_{CC}=2.7V$  to  $5.5V$  and  $T_{opr}=-40^{\circ}C$  to  $85^{\circ}C$ .
2. This shows the time until the voltage detection interrupt request is generated since the voltage passes  $V_{det}$ .
3. This shows the required time until the voltage detection circuit operates when setting to "1" again after setting the VC27 bit in the VCR2 register to "0".

**Table 5.7 Reset Circuit Electrical Characteristics (When Using Hardware Reset 2<sup>(1, 3)</sup>)**

Symbol	Parameter	Measuring condition	Standard			Unit
			Min.	Typ.	Max.	
Vpor2	Power-on reset valid voltage	$-20^{\circ}C \leq T_{opr} < 85^{\circ}C$	—	—	Vdet	V
tw(Vpor2-Vdet)	Supply voltage rising time when power-on reset is canceled <sup>(2)</sup>	$-20^{\circ}C \leq T_{opr} < 85^{\circ}C$ , $tw(por2) \geq 0s^{(4)}$	—	—	100	ms

## NOTES:

1. The voltage detection circuit which is embedded in a microcomputer is a factor to generate the hardware reset 2. Refer to 5.1.2 Hardware Reset 2 of Hardware Manual for details.
2. This condition is not applicable when using  $V_{CC} \geq 1.0V$ .
3. When turning power on after the external power has been held below the valid voltage ( $V_{por1}$ ) for greater than 10 seconds, refer to Table 5.8 Reset Circuit Electrical Characteristics (When Not Using Hardware Reset 2).
4.  $tw(por2)$  is time to hold the external power below effective voltage ( $V_{por2}$ ).

**Table 5.8 Reset Circuit Electrical Characteristics (When Not Using Hardware Reset 2)**

Symbol	Parameter	Measuring condition	Standard			Unit
			Min.	Typ.	Max.	
Vpor1	Power-on reset valid voltage	$-20^{\circ}C \leq T_{opr} < 85^{\circ}C$	—	—	0.1	V
tw(Vpor1-Vdet)	Supply voltage rising time when power-on reset is canceled	$0^{\circ}C \leq T_{opr} \leq 85^{\circ}C$ , $tw(por1) \geq 10s^{(2)}$	—	—	100	ms
tw(Vpor1-Vdet)	Supply voltage rising time when power-on reset is canceled	$-20^{\circ}C \leq T_{opr} < 0^{\circ}C$ , $tw(por1) \geq 30s^{(2)}$	—	—	100	ms
tw(Vpor1-Vdet)	Supply voltage rising time when power-on reset is canceled	$-20^{\circ}C \leq T_{opr} < 0^{\circ}C$ , $tw(por1) \geq 10s^{(2)}$	—	—	1	ms
tw(Vpor1-Vdet)	Supply voltage rising time when power-on reset is canceled	$0^{\circ}C \leq T_{opr} \leq 85^{\circ}C$ , $tw(por1) \geq 1s^{(2)}$	—	—	0.5	ms

## NOTES:

1. When not using hardware reset 2, use with  $V_{CC} \geq 2.7V$ .
2.  $tw(por1)$  is time to hold the external power below effective voltage ( $V_{por1}$ ).

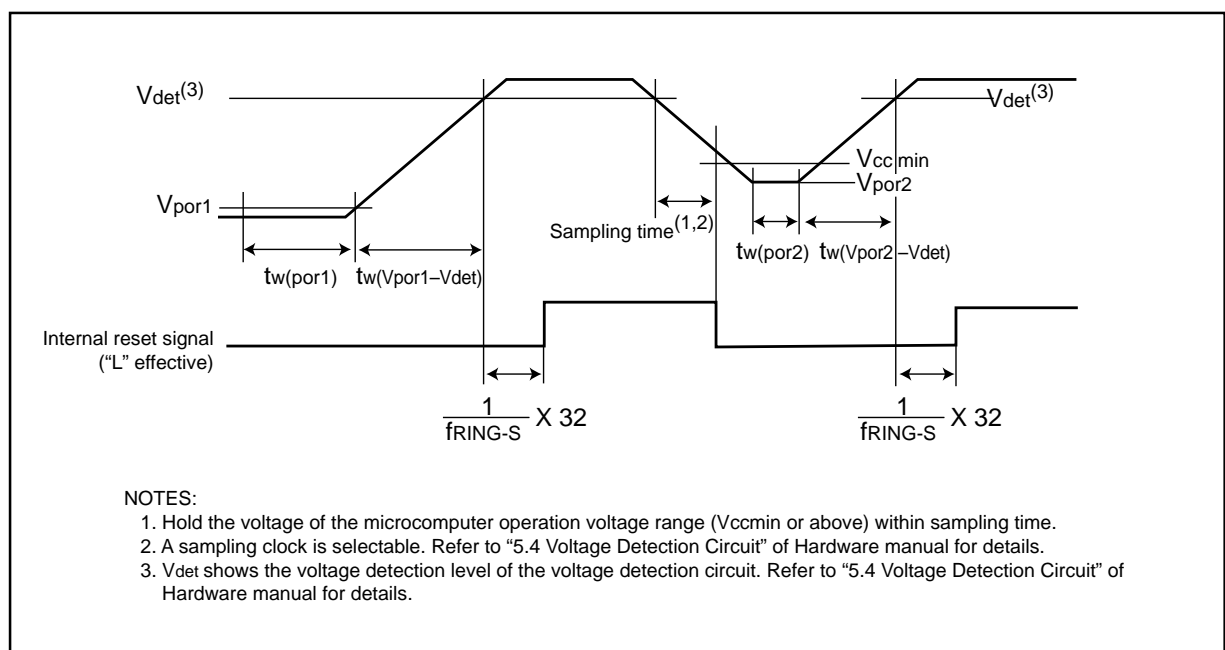
**Figure 5.3 Reset Circuit Electrical Characteristics**

**Table 5.9 High-speed On-Chip Oscillator Circuit Electrical Characteristics**

Symbol	Parameter	Measuring condition	Standard			Unit
			Min.	Typ.	Max.	
—	High-speed on-chip oscillator frequency 1 / {td(HRoffset)+td(HR)} when the reset is released	VCC=5.0V, Topr=25 °C Set "4016" in the HR1 register	—	8	—	MHz
td(HRoffset)	Settable high-speed on-chip oscillator minimum period	VCC=5.0V, Topr=25 °C Set "0016" in the HR1 register	—	61	—	ns
td(HR)	High-speed on-chip oscillator period adjusted unit	Differences when setting "0116" and "0016" in the HR register	—	1	—	ns
—	High-speed on-chip oscillator frequency temperature dependence(1)	Frequency fluctuation in temperature range of -10 °C to 50 °C	—	±5	—	%
—	High-speed on-chip oscillator frequency temperature dependence(2)	Frequency fluctuation in temperature range of -40 °C to 85 °C	—	±10	—	%

## NOTES:

1. The measuring condition is Vcc=AVcc=5.0 V and Topr=25 °C.

**Table 5.10 Power Circuit Timing Characteristics**

Symbol	Parameter	Measuring condition	Standard			Unit
			Min.	Typ.	Max.	
td(P-R)	Time for internal power supply stabilization during powering-on(2)		1		2000	μs
td(R-S)	STOP release time(3)				150	μs

## NOTES:

1. The measuring condition is Vcc=AVcc=2.7 to 5.5 V and Topr=25 °C.
2. This shows the wait time until the internal power supply generating circuit is stabilized during power-on.
3. This shows the time until BCLK starts from the interrupt acknowledgement to cancel stop mode.

**Table 5.11 Electrical Characteristics (1) [Vcc=5V]**

Symbol	Parameter		Measuring condition		Standard			Unit
					Min.	Typ.	Max.	
V <sub>OH</sub>	"H" output voltage	Except X <sub>OUT</sub>	I <sub>OH</sub> =5mA		Vcc-2.0	—	Vcc	V
			I <sub>OH</sub> =200μA		Vcc-0.3	—	Vcc	V
	X <sub>OUT</sub>	Drive capacity HIGH	I <sub>OH</sub> =-1 mA	Vcc-2.0	—	Vcc	V	
		Drive capacity LOW	I <sub>OH</sub> =-500μA	Vcc-2.0	—	Vcc	V	
V <sub>OL</sub>	"L" output voltage	Except P10 to P17, X <sub>OUT</sub>	I <sub>OL</sub> = 5 mA		—	—	2.0	V
			I <sub>OL</sub> = 200 μA		—	—	0.45	V
	P10 to P17	Drive capacity HIGH	I <sub>OL</sub> = 15 mA	—	—	2.0	V	
		Drive capacity LOW	I <sub>OL</sub> = 5 mA	—	—	2.0	V	
	X <sub>OUT</sub>	Drive capacity LOW	I <sub>OL</sub> = 200 μA	—	—	0.45	V	
		Drive capacity HIGH	I <sub>OL</sub> = 1 mA	—	—	2.0	V	
V <sub>T+</sub> -V <sub>T-</sub>	Hysteresis	INT0, INT1, INT2, INT3, K10, K11, K12, K13, CNTR0, CNTR1, TCIN, RxD0, RxD1, P45			0.2	—	1.0	V
		RESET			0.2	—	2.2	V
I <sub>IH</sub>	"H" input current		V <sub>I</sub> =5V		—	—	5.0	μA
I <sub>IL</sub>	"L" input current		V <sub>I</sub> =0V		—	—	-5.0	μA
R <sub>PULLUP</sub>	Pull-up resistance		V <sub>I</sub> =0V		30	50	167	kΩ
R <sub>XIN</sub>	Feedback resistance	X <sub>IN</sub>			—	1.0	—	MΩ
f <sub>RING-S</sub>	Low-speed on-chip oscillator frequency				40	125	250	kHz
V <sub>RAM</sub>	RAM retention voltage		At stop mode		2.0	—	—	V

## NOTES:

1. Referenced to Vcc = AVcc = 4.2 to 5.5V at Topr = -20 to 85 °C / -40 to 85 °C, f(X<sub>IN</sub>)=20MHz unless otherwise specified.

**Table 5.12 Electrical Characteristics (2) [V<sub>CC</sub>=5V]**

Symbol	Parameter	Measuring condition	Standard			Unit
			Min.	Typ.	Max.	
I <sub>CC</sub>	Power supply current (V <sub>CC</sub> =3.3 to 5.5V)  In single-chip mode, the output pins are open and other pins are V <sub>SS</sub>	High-speed mode X <sub>IN</sub> =20 MHz (square wave) High-speed on-chip oscillator off Low-speed on-chip oscillator on=125 kHz No division	—	9	15	mA
		X <sub>IN</sub> =16 MHz (square wave) High-speed on-chip oscillator off Low-speed on-chip oscillator on=125 kHz No division	—	8	14	mA
		X <sub>IN</sub> =10 MHz (square wave) High-speed on-chip oscillator off Low-speed on-chip oscillator on=125 kHz No division	—	5	—	mA
		Medium-speed mode X <sub>IN</sub> =20 MHz (square wave) High-speed on-chip oscillator off Low-speed on-chip oscillator on=125 kHz Division by 8	—	4	—	mA
		X <sub>IN</sub> =16 MHz (square wave) High-speed on-chip oscillator off Low-speed on-chip oscillator on=125 kHz Division by 8	—	3	—	mA
		X <sub>IN</sub> =10 MHz (square wave) High-speed on-chip oscillator off Low-speed on-chip oscillator on=125 kHz Division by 8	—	2	—	mA
		High-speed on-chip oscillator mode Main clock off High-speed on-chip oscillator on=8 MHz Low-speed on-chip oscillator on=125 kHz No division	—	4	8	mA
		Main clock off High-speed on-chip oscillator on=8 MHz Low-speed on-chip oscillator on=125 kHz Division by 8	—	1.5	—	mA
		Low-speed on-chip oscillator mode Main clock off High-speed on-chip oscillator off Low-speed on-chip oscillator on=125 kHz Division by 8	—	470	900	μA
		Wait mode Main clock off High-speed on-chip oscillator off Low-speed on-chip oscillator on=125 kHz When a WAIT instruction is executed <sup>(1)</sup> Peripheral clock operation VC27="0"	—	40	80	μA
		Wait mode Main clock off High-speed on-chip oscillator off Low-speed on-chip oscillator on=125 kHz When a WAIT instruction is executed <sup>(1)</sup> Peripheral clock off VC27="0"	—	38	76	μA
Stop mode Main clock off, T <sub>opr</sub> =-25 °C High-speed on-chip oscillator off Low-speed on-chip oscillator off CM10="1" Peripheral clock off VC27="0"	—	0.8	3.0	μA		

## NOTES:

1. Timer Y is operated with timer mode.
2. Referenced to V<sub>CC</sub> = AV<sub>CC</sub> = 4.2 to 5.5V at T<sub>opr</sub> = -20 to 85 °C / -40 to 85 °C, f(X<sub>IN</sub>)=20MHz unless otherwise specified.

**Timing requirements [V<sub>CC</sub>=5V] (Unless otherwise noted: V<sub>CC</sub> = 5V, V<sub>SS</sub> = 0V at T<sub>opr</sub> = 25 °C)****Table 5.13 X<sub>IN</sub> input**

Symbol	Parameter	Standard		Unit
		Min.	Max.	
t <sub>C</sub> (X <sub>IN</sub> )	X <sub>IN</sub> input cycle time	50	–	ns
t <sub>WH</sub> (X <sub>IN</sub> )	X <sub>IN</sub> input HIGH pulse width	25	–	ns
t <sub>WL</sub> (X <sub>IN</sub> )	X <sub>IN</sub> input LOW pulse width	25	–	ns

**Table 5.14 CNTR0 input, CNTR1 input,  $\overline{\text{INT2}}$  input**

Symbol	Parameter	Standard		Unit
		Min.	Max.	
t <sub>C</sub> (CNTR0)	CNTR0 input cycle time	100	–	ns
t <sub>WH</sub> (CNTR0)	CNTR0 input HIGH pulse width	40	–	ns
t <sub>WL</sub> (CNTR0)	CNTR0 input LOW pulse width	40	–	ns

**Table 5.15 TCIN input,  $\overline{\text{INT3}}$  input**

Symbol	Parameter	Standard		Unit
		Min.	Max.	
t <sub>C</sub> (TCIN)	TCIN input cycle time	400 <sup>(1)</sup>	–	ns
t <sub>WH</sub> (TCIN)	TCIN input HIGH pulse width	200 <sup>(2)</sup>	–	ns
t <sub>WL</sub> (TCIN)	TCIN input LOW pulse width	200 <sup>(2)</sup>	–	ns

**NOTES:**

1. When using the Timer C input capture mode, adjust the cycle time above ( 1/ Timer C count source frequency x 3).
2. When using the Timer C input capture mode, adjust the pulse width above ( 1/ Timer C count source frequency x 1.5).

**Table 5.5 Serial Interface**

Symbol	Parameter	Standard		Unit
		Min.	Max.	
t <sub>C</sub> (CK)	CLK <sub>i</sub> input cycle time	200	–	ns
t <sub>W</sub> (CKH)	CLK <sub>i</sub> input HIGH pulse width	100	–	ns
t <sub>W</sub> (CKL)	CLK <sub>i</sub> input LOW pulse width	100	–	ns
t <sub>d</sub> (C-Q)	TxD <sub>i</sub> output delay time	–	80	ns
t <sub>h</sub> (C-Q)	TxD <sub>i</sub> hold time	0	–	ns
t <sub>su</sub> (D-C)	RxD <sub>i</sub> input setup time	35	–	ns
t <sub>h</sub> (C-D)	RxD <sub>i</sub> input hold time	90	–	ns

**Table 5.17 External interrupt  $\overline{\text{INT0}}$  input**

Symbol	Parameter	Standard		Unit
		Min.	Max.	
t <sub>W</sub> (INH)	$\overline{\text{INT0}}$ input HIGH pulse width	250 <sup>(1)</sup>	–	ns
t <sub>W</sub> (INL)	$\overline{\text{INT0}}$ input LOW pulse width	250 <sup>(2)</sup>	–	ns

**NOTES:**

1. When selecting the digital filter by the  $\overline{\text{INT0}}$  input filter select bit, use the  $\overline{\text{INT0}}$  input HIGH pulse width to the greater value, either ( 1/ digital filter clock frequency x 3) or the minimum value of standard.
2. When selecting the digital filter by the  $\overline{\text{INT0}}$  input filter select bit, use the  $\overline{\text{INT0}}$  input LOW pulse width to the greater value, either ( 1/ digital filter clock frequency x 3) or the minimum value of standard.

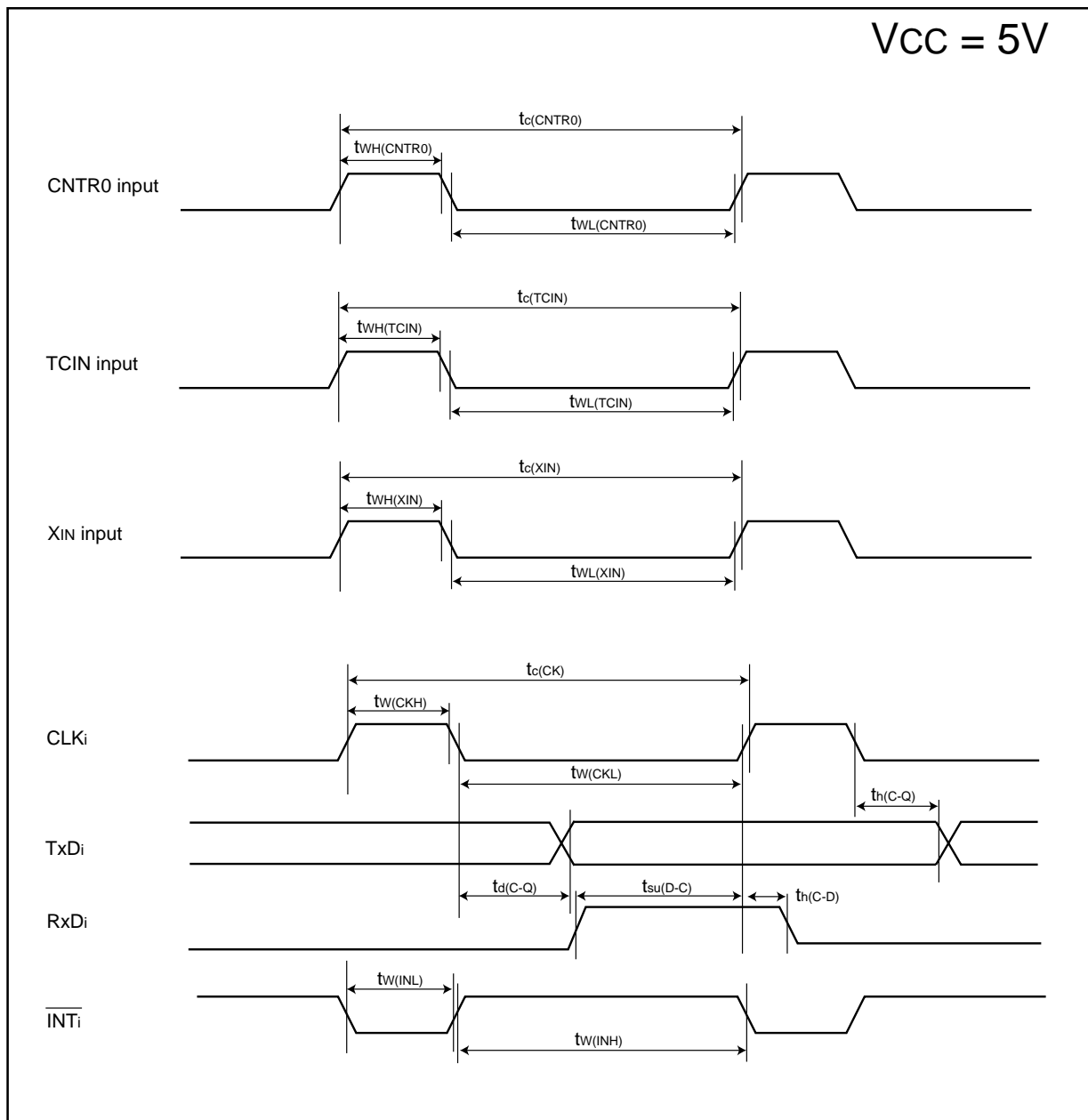

Figure 5.4 Vcc=5V timing diagram



**Table 5.18 Electrical Characteristics (3) [Vcc=3V]**

Symbol	Parameter		Measuring condition		Standard			Unit
					Min.	Typ.	Max.	
VOH	"H" output voltage	Except XOUT	IOH=-1mA		Vcc-0.5	—	Vcc	V
		XOUT	Drive capacity HIGH	IOH=-0.1 mA	Vcc-0.5	—	Vcc	v
			Drive capacity LOW	IOH=-50 μA	Vcc-0.5	—	Vcc	v
VOL	"L" output voltage	Except P10 to P17, XOUT	IOL= 1 mA		—	—	0.5	V
		P10 to P17	Drive capacity HIGH	IOL= 2 mA	—	—	0.5	V
			Drive capacity LOW	IOL= 1 mA	—	—	0.5	V
		XOUT	Drive capacity HIGH	IOL= 0.1 mA	—	—	0.5	V
			Drive capacity LOW	IOL=50 μA	—	—	0.5	V
VT+-VT-	Hysteresis	INT0, INT1, INT2, INT3, KI0, KI1, KI2, KI3, CNTR0, CNTR1, TCIN, RxD0, RxD1, P45			0.2	—	0.8	V
		RESET			0.2	—	1.8	V
IiH	"H" input current			Vi=3V	—	—	4.0	μA
IiL	"L" input current			Vi=0V	—	—	-4.0	μA
RPULLUP	Pull-up resistance			Vi=0V	66	160	500	kΩ
RfXIN	Feedback resistance	XIN			—	3.0	—	MΩ
fRING-S	Low-speed on-chip oscillator frequency				40	125	250	kHz
V <sub>RAM</sub>	RAM retention voltage			At stop mode	2.0	—	—	V

## NOTES:

1. Referenced to Vcc = AVcc = 2.7 to 3.3V at Topr = -20 to 85 °C / -40 to 85 °C, f(XIN)=10MHz unless otherwise specified.

**Table 5.19 Electrical Characteristics (4) [V<sub>CC</sub>=3V]**

Symbol	Parameter	Measuring condition	Standard			Unit
			Min.	Typ.	Max.	
I <sub>CC</sub>	Power supply current (V <sub>CC</sub> =2.7 to 3.3V) In single-chip mode, the output pins are open and other pins are V <sub>SS</sub>	High-speed mode X <sub>IN</sub> =20 MHz (square wave) High-speed on-chip oscillator off Low-speed on-chip oscillator on=125 kHz No division	—	8	13	mA
		X <sub>IN</sub> =16 MHz (square wave) High-speed on-chip oscillator off Low-speed on-chip oscillator on=125 kHz No division	—	7	12	mA
		X <sub>IN</sub> =10 MHz (square wave) High-speed on-chip oscillator off Low-speed on-chip oscillator on=125 kHz No division	—	5	—	mA
		Medium-speed mode X <sub>IN</sub> =20 MHz (square wave) High-speed on-chip oscillator off Low-speed on-chip oscillator on=125 kHz Division by 8	—	3	—	mA
		X <sub>IN</sub> =16 MHz (square wave) High-speed on-chip oscillator off Low-speed on-chip oscillator on=125 kHz Division by 8	—	2.5	—	mA
		X <sub>IN</sub> =10 MHz (square wave) High-speed on-chip oscillator off Low-speed on-chip oscillator on=125 kHz Division by 8	—	1.6	—	mA
		High-speed on-chip oscillator mode Main clock off High-speed on-chip oscillator on=8 MHz Low-speed on-chip oscillator on=125 kHz No division	—	3.5	7.5	mA
		Main clock off High-speed on-chip oscillator on=8 MHz Low-speed on-chip oscillator on=125 kHz Division by 8	—	1.5	—	mA
		Low-speed on-chip oscillator mode Main clock off High-speed on-chip oscillator off Low-speed on-chip oscillator on=125 kHz Division by 8	—	420	800	μA
		Wait mode Main clock off High-speed on-chip oscillator off Low-speed on-chip oscillator on=125 kHz When a WAIT instruction is executed <sup>(1)</sup> Peripheral clock operation VC27="0"	—	37	74	μA
Wait mode Main clock off High-speed on-chip oscillator off Low-speed on-chip oscillator on=125 kHz When a WAIT instruction is executed <sup>(1)</sup> Peripheral clock off VC27="0"	—	35	70	μA		
Stop mode Main clock off, Topr=-25 °C High-speed on-chip oscillator off Low-speed on-chip oscillator off CM10="1" Peripheral clock off VC27="0"	—	0.7	3.0	μA		

## NOTES:

1. Timer Y is operated with timer mode.
2. Referenced to V<sub>CC</sub> = AV<sub>CC</sub> = 2.7 to 3.3V at Topr = -20 to 85 °C / -40 to 85 °C, f(X<sub>IN</sub>)=10MHz unless otherwise specified.

**Timing requirements [V<sub>CC</sub>=3V] (Unless otherwise noted: V<sub>CC</sub> = 3V, V<sub>SS</sub> = 0V at Topr = 25 °C)****Table 5.20 XIN input**

Symbol	Parameter	Standard		Unit
		Min.	Max.	
t <sub>C</sub> (XIN)	XIN input cycle time	100	–	ns
t <sub>WH</sub> (XIN)	XIN input HIGH pulse width	40	–	ns
t <sub>WL</sub> (XIN)	XIN input LOW pulse width	40	–	ns

**Table 5.21 CNTR0 input, CNTR1 input,  $\overline{\text{INT2}}$  input**

Symbol	Parameter	Standard		Unit
		Min.	Max.	
t <sub>C</sub> (CNTR0)	CNTR0 input cycle time	300	–	ns
t <sub>WH</sub> (CNTR0)	CNTR0 input HIGH pulse width	120	–	ns
t <sub>WL</sub> (CNTR0)	CNTR0 input LOW pulse width	120	–	ns

**Table 5.22 TCIN input,  $\overline{\text{INT3}}$  input**

Symbol	Parameter	Standard		Unit
		Min.	Max.	
t <sub>C</sub> (TCIN)	TCIN input cycle time	1200 <sup>(1)</sup>	–	ns
t <sub>WH</sub> (TCIN)	TCIN input HIGH pulse width	600 <sup>(2)</sup>	–	ns
t <sub>WL</sub> (TCIN)	TCIN input LOW pulse width	600 <sup>(2)</sup>	–	ns

**NOTES:**

1. When using the Timer C input capture mode, adjust the cycle time above ( 1/ Timer C count source frequency x 3).
2. When using the Timer C input capture mode, adjust the pulse width above ( 1/ Timer C count source frequency x 1.5).

**Table 5.23 Serial Interface**

Symbol	Parameter	Standard		Unit
		Min.	Max.	
t <sub>C</sub> (CK)	CLKi input cycle time	300	–	ns
t <sub>W</sub> (CKH)	CLKi input HIGH pulse width	150	–	ns
t <sub>W</sub> (CKL)	CLKi input LOW pulse width	150	–	ns
t <sub>d</sub> (C-Q)	TxDi output delay time	–	160	ns
t <sub>h</sub> (C-Q)	TxDi hold time	0	–	ns
t <sub>su</sub> (D-C)	RxDi input setup time	55	–	ns
t <sub>h</sub> (C-D)	RxDi input hold time	90	–	ns

**Table 5.24 External interrupt  $\overline{\text{INT0}}$  input**

Symbol	Parameter	Standard		Unit
		Min.	Max.	
t <sub>W</sub> (INH)	$\overline{\text{INT0}}$ input HIGH pulse width	380 <sup>(1)</sup>	–	ns
t <sub>W</sub> (INL)	$\overline{\text{INT0}}$ input LOW pulse width	380 <sup>(2)</sup>	–	ns

**NOTES:**

1. When selecting the digital filter by the  $\overline{\text{INT0}}$  input filter select bit, use the  $\overline{\text{INT0}}$  input HIGH pulse width to the greater value, either ( 1/ digital filter clock frequency x 3) or the minimum value of standard.
2. When selecting the digital filter by the  $\overline{\text{INT0}}$  input filter select bit, use the  $\overline{\text{INT0}}$  input LOW pulse width to the greater value, either ( 1/ digital filter clock frequency x 3) or the minimum value of standard.

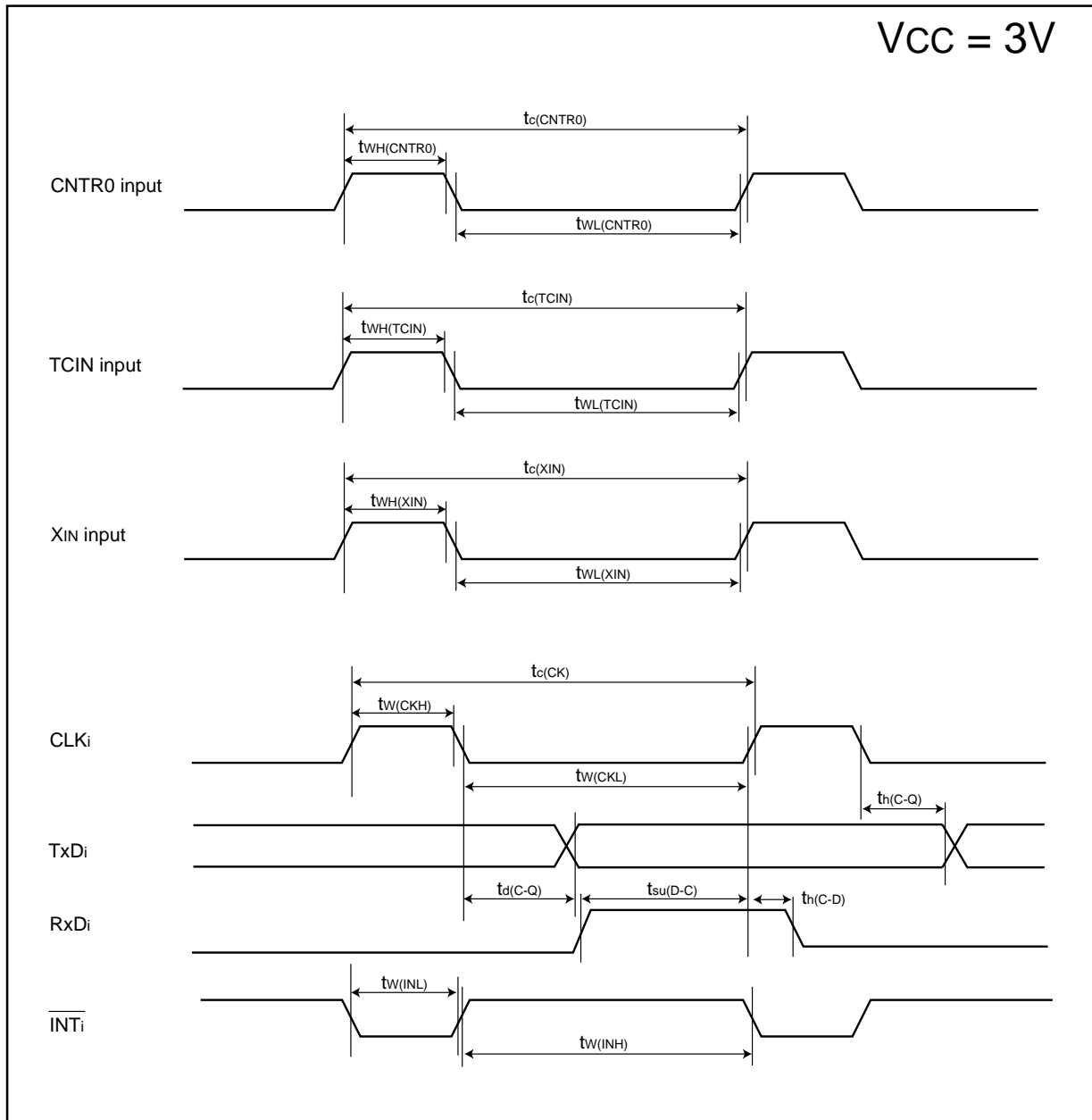
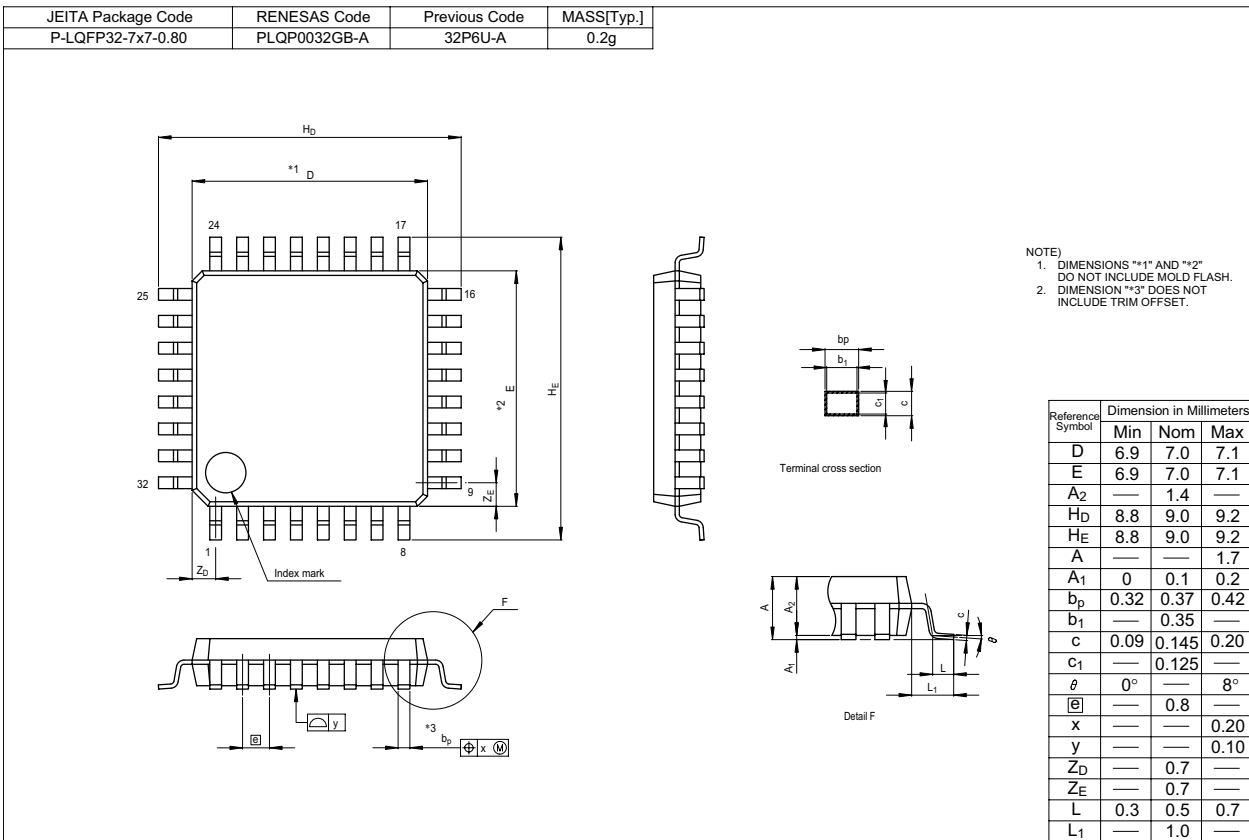

Figure 5.5 Vcc=3V timing diagram

### Package Dimensions



REVISION HISTORY

R8C/13 Group Datasheet

Rev.	Date	Description	
		Page	Summary
0.10	Oct 28, 2003		First edition issued
0.20	Dec05, 2003	5	Figure 1.3 revised
		10	Chapter 4, NOTES revised
		16	Table 5.4 revised Table 5.5 revised
		17	Table 5.6 revised Figure 5.3 added
		18	Table 5.8 revised Table 5.10 revised
		21	Figure 5.3 revised to Figure 5.4
		22	Table 5.17 revised
		25	Figure 5.4 revised to Figure 5.5
1.00	Sep 30, 2004	All pages	Words standardized (on-chip oscillator, serial interface, A/D)
		2	Table 1.1 revised
		5	Figure 1.3, NOTES 3 added
		6	Table 1.3 revised
		9	Figure 3.1, NOTES added
		10-13	One body sentence in chapter 4 added ; Titles of Table 4.1 to 4.4 added
		12	Table 4.3 revised ; Table 4.4 revised
		14	Table 5.2 revised
		15	Table 5.3 revised
		16	Table 5.4 and Table 5.5 revised
		17	Table 5.6, 5.7 and 5.8 revised ; Figure 5.3 revised
		18	Table 5.9 and 5.11 revised
		19	Table 5.12 revised
		20	Table 5.13 revised
22	Table 5.18 revised		
23	Table 5.19 revised		
24	Table 5.20 and Table 5.24 revised		
1.10	Apr.27.2005	4	Table 1.2, Figure 1.2 package name revised
		5	Figure 1.3 package name revised
		10	Table 4.1 revised
		12	Table 4.3 revised
		15	Table 5.3 partly revised
		16	Table 5.4, Table 5.5 partly added

REVISION HISTORY

R8C/13 Group Datasheet

Rev.	Date	Description	
		Page	Summary
1.10	Apr.27.2005	17	Table 5.7, 5.8 revised
		18	Table 5.10, Table 5.11 partly revised
		22	Table 5.18 partly revised
		26	Package Dimensions revised
1.20	Jan.27.2006	2	Table 1.1 Performance outline revised
		3	Figure 1.1 Block diagram partly revised
		4	1.4 Product Information, title of Table 1.2 "Product List" → "Product Informaton" revised ROM capacity; "Program area" → "Program ROM", "Data area" → "Data flash" revised
		6	Figure 1.2 Type No., Memory Size, and Package partly revised
		7-8	Table 1.3 Pin description revised 2 Central Processing Unit (CPU) revised Figure 2.1 CPU register revised
		9	3 Memory, Figure 3.1 Memory Map; "Program area" → "Program ROM", "Data area" → "Data flash" revised
		10	Table 4.1 SFR Information(1) NOTES:1 revised
		11	Table 4.2 SFR Information(2) NOTES:1 revised
		12	Table 4.3 SFR Information(3); 0081 <sub>16</sub> : "Prescaler Y" → "Prescaler Y Register" 0082 <sub>16</sub> : "Timer Y Secondary" → "Timer Y Secondary Register" 0083 <sub>16</sub> : "Timer Y Primary" → "Timer Y Primary Register" 0085 <sub>16</sub> : "Prescaler Z" → "Prescaler Z Register" 0086 <sub>16</sub> : "Timer Z Secondary" → "Timer Z Secondary Register" 0087 <sub>16</sub> : "Timer Z Primary" → "Timer Z Primary Register" 008C <sub>16</sub> : "Prescaler X" → "Prescaler X Register" revised NOTES:1, 2 revised
		13	Table 4.4 SFR Information(4) NOTES:1 revised
		14	Table 5.2 Recommended Operating Conditions; NOTES: 1, 2, 3 revised
		15	Table 5.3 A/D Conversion Characteristics; "A/D operation clock frequency" → "A/D operating clock frequency" revised NOTES: 1, 2, 3, 4 revised
		16	Table 5.4 Flash Memory (Program ROM) Electrical Characteristics; "Data retention duration" → "Data hold time" revised "Topr" → "Ambient temperature" NOTES: 1 to 7 added Measuring condition of byte program time and block erase time deleted
		17	Table 5.5 Flash Memory (Data flash Block A, Block B) Electrical characteristics "Data retention duration" → "Data hold time" revised "Topr" → "Ambient temperature" NOTES: 1, 3 revised, NOTES: 9 added Measuring condition of byte program time and block erase time deleted
		18	Table 5.7 Reset Circuit Electrical Characteristics (When Using Hardware Reset 2) NOTES: 3 revised
		19	Table 5.9 High-speed On-Chip Oscillator Circuit Electrical Characteristics; "High-speed on-chip oscillator temperature dependence" → "High-speed on-chip oscillator frequency temperature dependence" revised Table 5.11 Electrical Characteristics (1) [V <sub>CC</sub> =5V]; "P1 <sub>0</sub> to P1 <sub>7</sub> Except X <sub>OUT</sub> " → "Except P1 <sub>0</sub> to P1 <sub>7</sub> , X <sub>OUT</sub> " revised

REVISION HISTORY

R8C/13 Group Datasheet

Rev.	Date	Description	
		Page	Summary
1.20	Jan.27.2006	20	Table 5.12 Electrical Characteristics (2) [V <sub>CC</sub> =5V]; NOTES: 1, 2 revised Measuring condition Stop mode: "Topr=-25 °C" added
		23	Table 5.18 Electrical Characteristics (3) [V <sub>CC</sub> =3V] "P1 <sub>0</sub> to P1 <sub>7</sub> Except X <sub>OUT</sub> " → "Except P1 <sub>0</sub> to P1 <sub>7</sub> , X <sub>OUT</sub> " revised
		24	Table 5.19 Electrical Characteristics (4) [V <sub>CC</sub> =3V] NOTES: 1, 2 revised Measuring condition Stop mode: "Topr=-25 °C" added



**Keep safety first in your circuit designs!**

1. Renesas Technology Corp. puts the maximum effort into making semiconductor products better and more reliable, but there is always the possibility that trouble may occur with them. Trouble with semiconductors may lead to personal injury, fire or property damage.  
Remember to give due consideration to safety when making your circuit designs, with appropriate measures such as (i) placement of substitutive, auxiliary circuits, (ii) use of nonflammable material or (iii) prevention against any malfunction or mishap.

**Notes regarding these materials**

1. These materials are intended as a reference to assist our customers in the selection of the Renesas Technology Corp. product best suited to the customer's application; they do not convey any license under any intellectual property rights, or any other rights, belonging to Renesas Technology Corp. or a third party.
  2. Renesas Technology Corp. assumes no responsibility for any damage, or infringement of any third-party's rights, originating in the use of any product data, diagrams, charts, programs, algorithms, or circuit application examples contained in these materials.
  3. All information contained in these materials, including product data, diagrams, charts, programs and algorithms represents information on products at the time of publication of these materials, and are subject to change by Renesas Technology Corp. without notice due to product improvements or other reasons. It is therefore recommended that customers contact Renesas Technology Corp. or an authorized Renesas Technology Corp. product distributor for the latest product information before purchasing a product listed herein.  
The information described here may contain technical inaccuracies or typographical errors.  
Renesas Technology Corp. assumes no responsibility for any damage, liability, or other loss rising from these inaccuracies or errors.  
Please also pay attention to information published by Renesas Technology Corp. by various means, including the Renesas Technology Corp. Semiconductor home page (<http://www.renesas.com>).
  4. When using any or all of the information contained in these materials, including product data, diagrams, charts, programs, and algorithms, please be sure to evaluate all information as a total system before making a final decision on the applicability of the information and products. Renesas Technology Corp. assumes no responsibility for any damage, liability or other loss resulting from the information contained herein.
  5. Renesas Technology Corp. semiconductors are not designed or manufactured for use in a device or system that is used under circumstances in which human life is potentially at stake. Please contact Renesas Technology Corp. or an authorized Renesas Technology Corp. product distributor when considering the use of a product contained herein for any specific purposes, such as apparatus or systems for transportation, vehicular, medical, aerospace, nuclear, or undersea repeater use.
  6. The prior written approval of Renesas Technology Corp. is necessary to reprint or reproduce in whole or in part these materials.
  7. If these products or technologies are subject to the Japanese export control restrictions, they must be exported under a license from the Japanese government and cannot be imported into a country other than the approved destination.  
Any diversion or reexport contrary to the export control laws and regulations of Japan and/or the country of destination is prohibited.
  8. Please contact Renesas Technology Corp. for further details on these materials or the products contained therein.
- 



**RENESAS SALES OFFICES**

<http://www.renesas.com>

Refer to "<http://www.renesas.com/en/network>" for the latest and detailed information.

**Renesas Technology America, Inc.**

450 Holger Way, San Jose, CA 95134-1368, U.S.A  
Tel: <1> (408) 382-7500, Fax: <1> (408) 382-7501

**Renesas Technology Europe Limited**

Dukes Meadow, Millboard Road, Bourne End, Buckinghamshire, SL8 5FH, U.K.  
Tel: <44> (1628) 585-100, Fax: <44> (1628) 585-900

**Renesas Technology (Shanghai) Co., Ltd.**

Unit 205, AZIA Center, No.133 Yincheng Rd (n), Pudong District, Shanghai 200120, China  
Tel: <86> (21) 5877-1818, Fax: <86> (21) 6887-7898

**Renesas Technology Hong Kong Ltd.**

7th Floor, North Tower, World Finance Centre, Harbour City, 1 Canton Road, Tsimshatsui, Kowloon, Hong Kong  
Tel: <852> 2265-6688, Fax: <852> 2730-6071

**Renesas Technology Taiwan Co., Ltd.**

10th Floor, No.99, Fushing North Road, Taipei, Taiwan  
Tel: <886> (2) 2715-2888, Fax: <886> (2) 2713-2999

**Renesas Technology Singapore Pte. Ltd.**

1 Harbour Front Avenue, #06-10, Keppel Bay Tower, Singapore 098632  
Tel: <65> 6213-0200, Fax: <65> 6278-8001

**Renesas Technology Korea Co., Ltd.**

Kukje Center Bldg. 18th Fl., 191, 2-ka, Hangang-ro, Yongsan-ku, Seoul 140-702, Korea  
Tel: <82> (2) 796-3115, Fax: <82> (2) 796-2145

**Renesas Technology Malaysia Sdn. Bhd**

Unit 906, Block B, Menara Amcorp, Amcorp Trade Centre, No.18, Jalan Persiaran Barat, 46050 Petaling Jaya, Selangor Darul Ehsan, Malaysia  
Tel: <603> 7955-9390, Fax: <603> 7955-9510

# Mouser Electronics

Authorized Distributor

Click to View Pricing, Inventory, Delivery & Lifecycle Information:

## Renesas Electronics:

[R5F21132DFP#U0](#) [R5F21134FP#U0](#) [R5F21134DFP#U0](#) [R5F21133FP#U0](#) [R5F21134FP#W4](#) [R5F21132FP#U0](#)



Компания «ЭлектроПласт» предлагает заключение долгосрочных отношений при поставках импортных электронных компонентов на взаимовыгодных условиях!

Наши преимущества:

- Оперативные поставки широкого спектра электронных компонентов отечественного и импортного производства напрямую от производителей и с крупнейших мировых складов;
- Поставка более 17-ти миллионов наименований электронных компонентов;
- Поставка сложных, дефицитных, либо снятых с производства позиций;
- Оперативные сроки поставки под заказ (от 5 рабочих дней);
- Экспресс доставка в любую точку России;
- Техническая поддержка проекта, помощь в подборе аналогов, поставка прототипов;
- Система менеджмента качества сертифицирована по Международному стандарту ISO 9001;
- Лицензия ФСБ на осуществление работ с использованием сведений, составляющих государственную тайну;
- Поставка специализированных компонентов (Xilinx, Altera, Analog Devices, Intersil, Interpoint, Microsemi, Aeroflex, Peregrine, Syfer, Eurofarad, Texas Instrument, Miteq, Cobham, E2V, MA-COM, Hittite, Mini-Circuits, General Dynamics и др.);

Помимо этого, одним из направлений компании «ЭлектроПласт» является направление «Источники питания». Мы предлагаем Вам помощь Конструкторского отдела:

- Подбор оптимального решения, техническое обоснование при выборе компонента;
- Подбор аналогов;
- Консультации по применению компонента;
- Поставка образцов и прототипов;
- Техническая поддержка проекта;
- Защита от снятия компонента с производства.



#### Как с нами связаться

**Телефон:** 8 (812) 309 58 32 (многоканальный)

**Факс:** 8 (812) 320-02-42

**Электронная почта:** [org@eplast1.ru](mailto:org@eplast1.ru)

**Адрес:** 198099, г. Санкт-Петербург, ул. Калинина, дом 2, корпус 4, литера А.