

AS Series

INRUSH CURRENT LIMITERS

Thermistor Protection for Precharge Circuit on Lithium Ion Batteries

When a battery is connected to a load with capacitive input, there is an Inrush current surge as the capacitance is being charged to the battery voltage. The Input current depends on the input capacitance; the larger the batteries and the more powerful the load, the larger the input capacitance. A large Inrush current (in the precharge circuit, without protection) can cause the following:

- Damage to input filter capacitors
- Blowing of the main fuse if asked to carry the inrush current without protection
- Contact failure (as well as reduction in current carrying capacity) due to arcing and pitting that results from high inrush current
- Damage to the battery cell, which is not rated for inrush current

A typical precharge circuitry for battery operation is below with the timing diagram, showing how the circuit operates. (Courtesy of Lithium -ION BMS)

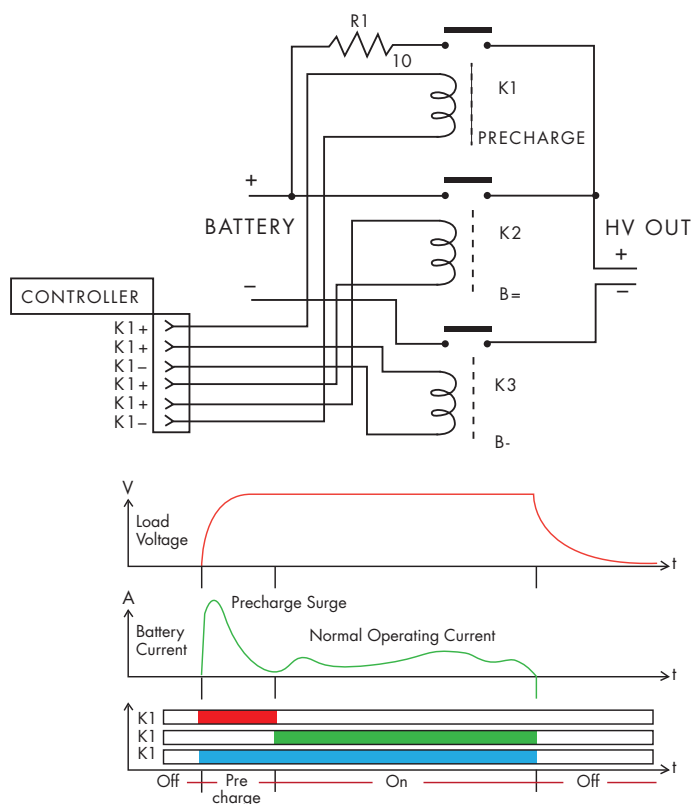

In its most basic form, the Precharge circuit operates as follows:

- **OFF:** When the system is OFF all relays / contactors are off.
- **Precharge:** When the system is first turned on, K1 and K3 are turned on to Precharge the load, until the Inrush current has subsided. R1 shows the location of Thermistor in the Precharge circuit.
- **ON:** After Precharge, contactor K2 is turned on (relay K1, must be off to save coil power)

For this application note, let us limit our discussion to the selection of the Thermistor

SELECTION OF THE THERMISTOR

The minimum resistance of the thermistor is determined by the following:

1. Ambient temperature
2. Input capacitance value (of the precharge circuit)
3. Battery voltage

The precharge surge current reaches 63.2% (1/e) of its initial value after a time $\tau = RC$.

In the selection of the thermistor, we consider a time value of "five time-constant" when the capacitances are fully charged and the surge current reaches the normal operating current.

For the purpose of our design, let us assume the following quantitative values:

Precharge time: 20 millisecond

Ambient operating temperature: Varies between 10°C to 50°C.

Battery voltage: 100 volt

Capacitor bank : 50,000 μ F

$5\tau = RC$

$R = 5\tau / C = 5 (0.02 \text{ sec}) / 0.05F = 2.0 \Omega$.

Now, look at the at R-T curves for Ametherm thermistor at ambient of 50°C. The material "C" exhibits

$R @ 50^\circ\text{C} / R @ 25^\circ\text{C} = 0.412 @ R @ 10^\circ\text{C} / R @ 25^\circ\text{C} = 1.70$

Therefore, minimum resistance @ 25°C = $2.0 / 0.454 = 4.40\Omega$, so our standard part has 5.0 ohm nominal resistance

At 10°C, the standard part will have a resistance of $5.0 \Omega \times 1.70 = 8.50 \Omega$, which will meet our minimum resistance.

Determine the energy the thermistor needs to handle with out self-destruction,

$E = \frac{1}{2} C V^2 = \frac{1}{2} (0.05) (100)^2 = 250 \text{ Joules}$.

The steady state current is not calculated because in most precharge circuits the steady state current goes through the contactor.

The part, which would meet your specification, is AS32 5R020.

AS Series

INRUSH CURRENT LIMITERS

Key Benefits of Ametherm AS Inrush Current Limiters

- Lower current density (as compared to traditional types of inrush current limiters)
- Faster reset time
- No hot spots from fatigue, because of lower current density and uniform temperature gradient throughout the disc
- Wider temperature range of operation with out de-rating

ELECTRICAL SPECIFICATIONS

Part Number	R@25°C (Ω)	MAX I (A)	HOT R (Ω)	MAX ENERGY (JOULES)	Max Cap @680VAC	Cooldown time (sec)	R - T curve	DC mW/°C	Body Temp @ Max SSI (°C)
*AS32 0R530	0.50	30	0.011	300	650	120	A	78.20	199
*AS32 0R536	0.50	36	0.009	300	650	120	A	78.20	199
*AS32 1R030	1.0	30	0.013	300	650	120	B	79.40	215
*AS32 1R036	1.0	36	0.010	300	650	120	B	79.40	215
AS32 2R025	2.0	25	0.020	300	650	120	C	78.20	220
AS32 5R020	5.0	20	0.027	300	650	120	G	78.20	255
AS32 10015	10.0	15	0.052	250	500	120	H	85.20	185
AS32 20010	20.0	10	0.095	250	500	120	I	58.00	192
AS32 50006	50.0	6	0.380	250	540	120	M	78.20	212
AS35 0R550	0.50	50	0.0074	800	1730	200	A	129.44	210
AS35 1R040	1.0	40	0.0113	800	1730	200	B	127.00	212
AS35 2R035	2.0	35	0.0147	700	1500	200	C	119.20	210
AS35 3R030	3.0	30	0.0135	600	1300	200	C	116.40	215
AS35 5R025	5.0	25	0.0288	600	1300	200	G	112.2	208
AS35 10018	10.0	18	0.0556	500	1080	200	I	122.80	220
AS35 20010	20.0	10	0.1760	500	1080	200	M	101.10	177

MECHANICAL SPECIFICATIONS

Part Number	D (mm)	T (mm)	S (mm)	L (mm)	A (mm)	B (mm)	C (mm)	X (mm)	Y (mm)
*AS32 0R530	30.0	7.8	17.1	22.0	2.2	4.8	0.8	17.1	4.8
*AS32 0R536	30.0	7.8	17.1	22.0	2.2	4.8	0.8	17.1	4.8
*AS32 1R030	30.0	7.8	17.1	22.0	2.2	4.8	0.8	17.1	4.8
*AS32 1R036	30.0	7.8	17.1	22.0	2.2	4.8	0.8	17.1	4.8
AS32 2R025	30.0	7.8	17.1	22.0	2.2	4.8	0.8	17.1	4.8
AS32 5R020	30.0	8.2	17.1	22.0	2.2	5.4	0.8	17.1	5.4
AS32 10015	30.0	9.0	17.1	22.0	2.2	6.8	0.8	17.1	6.8
AS32 20010	30.0	8.5	17.1	22.0	2.2	6.4	0.8	17.1	6.4
AS32 50006	30.0	8.2	17.1	22.0	2.2	5.4	0.8	17.1	5.4
AS35 0R550	36.0	6.4	19.0	22.0	2.2	3.4	0.8	19.0	3.4
AS35 1R040	36.0	8.5	19.0	22.0	2.2	5.5	0.8	19.0	5.5
AS35 2R035	36.0	8.5	19.0	22.0	2.2	5.5	0.8	19.0	5.5
AS35 3R030	36.0	8.5	19.0	22.0	2.2	5.5	0.8	19.0	5.5
AS35 5R025	36.0	8.5	19.0	22.0	2.2	5.5	0.8	19.0	5.5
AS35 10018	36.0	8.5	19.0	22.0	2.2	5.5	0.8	19.0	5.5
AS35 20010	36.0	8.5	19.0	22.0	2.2	5.5	0.8	19.0	5.5

*(UL Approved)

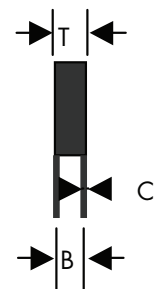
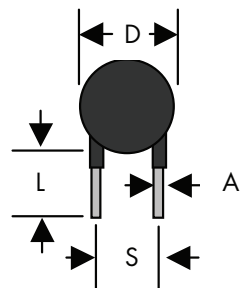

PAD LAYOUT

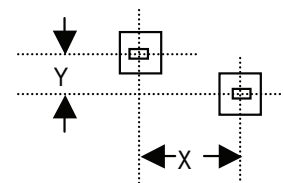

T: 800-808-2434
775-884-2434
(Outside the US and Canada)
F: 775-884-0670
www.ametherm.com
info@ametherm.com

3111 N. Deer Run Road
Carson City, Nevada
89701 USA



Компания «ЭлектроПласт» предлагает заключение долгосрочных отношений при поставках импортных электронных компонентов на взаимовыгодных условиях!

Наши преимущества:

- Оперативные поставки широкого спектра электронных компонентов отечественного и импортного производства напрямую от производителей и с крупнейших мировых складов;
- Поставка более 17-ти миллионов наименований электронных компонентов;
- Поставка сложных, дефицитных, либо снятых с производства позиций;
- Оперативные сроки поставки под заказ (от 5 рабочих дней);
- Экспресс доставка в любую точку России;
- Техническая поддержка проекта, помощь в подборе аналогов, поставка прототипов;
- Система менеджмента качества сертифицирована по Международному стандарту ISO 9001;
- Лицензия ФСБ на осуществление работ с использованием сведений, составляющих государственную тайну;
- Поставка специализированных компонентов (Xilinx, Altera, Analog Devices, Intersil, Interpoint, Microsemi, Aeroflex, Peregrine, Syfer, Eurofarad, Texas Instrument, Miteq, Cobham, E2V, MA-COM, Hittite, Mini-Circuits, General Dynamics и др.);

Помимо этого, одним из направлений компании «ЭлектроПласт» является направление «Источники питания». Мы предлагаем Вам помощь Конструкторского отдела:

- Подбор оптимального решения, техническое обоснование при выборе компонента;
- Подбор аналогов;
- Консультации по применению компонента;
- Поставка образцов и прототипов;
- Техническая поддержка проекта;
- Защита от снятия компонента с производства.



Как с нами связаться

Телефон: 8 (812) 309 58 32 (многоканальный)

Факс: 8 (812) 320-02-42

Электронная почта: org@eplast1.ru

Адрес: 198099, г. Санкт-Петербург, ул. Калинина, дом 2, корпус 4, литера А.