

6-Bit SERIAL/PARALLEL SWITCH DRIVER/CONTROLLER

Typical Applications

The HMC677LP5(E) is ideal for:

- Microwave and Millimeterwave Control Circuits
- Test and Measurement Equipment
- Complex Multi-Function Assemblies
- Military and Space Subsystems
- Transmit/Receive Module Controllers

Features

- Accepts Serial or Parallel Data
- Compatible with TTL and CMOS Logic
- Complementary Outputs
- 6-Bit Control Word
- Power-up State Selection
- Low Power Consumption
- Fast Clock Rate

Functional Diagram

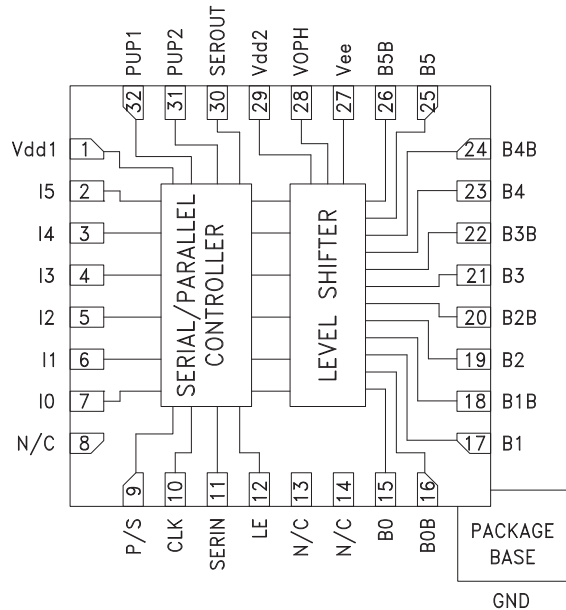

General Description

The HMC677LP5(E) is a multi-function BiCMOS control interface IC which is ideal for driving the gates of FET and pHEMT based MMIC control devices. This unique IC can be used to simplify the control of microwave and millimeterwave transmit/receive modules, military subsystems, and multithrow/multiport test and measurement equipment. The HMC677LP5(E) accepts serial or parallel data, and can drive up to 6 complementary sets of outputs.

The HMC677LP5(E) also provides additional functionality such as a power-up state selection, adjustable output voltage levels, and a latched parallel control mode which allows multiple control devices to share a common data bus. The HMC677LP5(E) is ideal for controlling digital phase shifters, digital attenuators, digital variable gain amplifiers, and switching matrices embedded in complex microwave and millimeterwave assemblies.

Electrical Specifications, $T_A = +25^\circ\text{C}$, $V_{dd1} = V_{dd2} = +5\text{V}$, $V_{ee} = -5\text{V}$, $V_{oph} = 0\text{V}$

Parameter	Min	Typ	Max	Units
Input High Voltage, V_{ih}	2	-	-	V
Low Voltage, V_{il}	-	-	0.8	V
Output High Voltage, V_{oh} ($I_{oh} = 1\text{ mA}$, $V_{ee} = -4.5\text{V}$)	$V_{oph} - 0.1$	-	-	V
Output Low Voltage, V_{ol} ($I_{ol} = 2\text{ mA}$, $V_{ee} = -4.5\text{V}$)	-	-	$V_{ee} + 0.1$	V
Maximum Input Leakage Current, I_{in}	-	-	1	μA
Propagation Delay, t_{plh}	-	-	80	nS
Maximum Serial Bit Rate	-	-	10	Mbps
Maximum I/O Update Rate	-	-	100	ns

6-Bit SERIAL/PARALLEL SWITCH DRIVER/CONTROLLER

Operating Ranges

Function	Parameter	Min.	Typ.	Max	Units
Vdd	Positive DC Supply Voltage	4.5	5.0	5.5	V
Vee	Negative DC Supply Voltage	-5.5	-5.0	-4.5	V
Voph ^[1]	DC Output Supply	0	-	2.2	V
Voph - Vee	Negative Supply Voltage Range	4.5	-	7.7	V
Vdd - Vee	Positive to Negative Supply Range	9	10	11	V
Ta	Operating Ambient Temperature	-40	25	85	C
Ioh ^[2]	DC Output Current - High	1	-	-	mA
Iol ^[2]	DC Output Current - Low	2	-	-	mA

[1] Voph can be used from 0V to 2.2V. Higher voltages can be used to increase low frequency performance of GaAs switches.

[2] Ioh and Iol are measured at 0.1V variation from Voph and Vee.

DC Characteristics

Function	Parameter	Conditions		Min.	Typ.	Max	Units
Vih	Input High Voltage	High Input Voltage		2.0	-	-	V
Vil	Input Low Voltage	Low Input Voltage		-	-	0.8	V
Voh	Output High Voltage	Ioh = 1 mA	Vee = -4.5V	Voph - 0.1	-	-	V
Vol	Output Low Voltage	Iol = 2 mA	Vee = -4.5V	-	-	Vee + 0.1	V
Iin	Input Leakage Current	Vin = Vdd or GND	Vdd = Max	-	-	1	μA
Idd	Quiescent Supply Current	Vdd = Max	Vin = Vdd or GND	-	-	1.5	mA
^ Idd	Additional Supply Current Per TTL Input Pin	Vdd = Max	Vin = 2V	-	-	50	μA

Worst Case AC Characteristics at Voph = 2.2V (Vdd = 4.5V, Vee = -4.5V)

Function	Parameter	-40 °C	+25 °C	+85 °C	Units
Tplh	Rising Propagation Delay	30	30	30	ns
Tphl	Falling Propagation Delay	30	30	30	ns
Ttth	Output Rising Transition Time	30	40	40	ns
Tthl	Output Falling Transition Time	15	20	20	ns
Tskew	Delay Skew	50	50	50	nS
Cpdd ^[1]	Power Dissipation Capacitance of Vdd	100	100	100	pF
Cpde ^[1]	Power Dissipation Capacitance of Vee	400	400	400	pF

Worst Case AC Characteristics at Voph = 0V (Vdd = 4.5V, Vee = -4.5V)

Function	Parameter	-40 °C	+25 °C	+85 °C	Units
Tplh	Rising Propagation Delay	80	80	80	ns
Tphl	Falling Propagation Delay	80	80	80	ns
Ttth	Output Rising Transition Time	100	100	100	ns
Tthl	Output Falling Transition Time	50	50	50	ns
Tskew	Delay Skew	50	50	50	nS
Cpdd ^[1]	Power Dissipation Capacitance of Vdd	100	100	100	pF
Cpde ^[1]	Power Dissipation Capacitance of Vee	400	400	400	pF

¹ Total Power Dissipation is calculated by the following formula: PD = Vdd² f Cpdd + (Voph - Vee)² f Cpde, where f = frequency in Hz

6-Bit SERIAL/PARALLEL SWITCH DRIVER/CONTROLLER

Serial Control Interface

The HMC677LP5(E) contains a 3-wire SPI compatible digital interface (DATA, CLK, LE). It is activated when P/S is kept high. The 6-bit serial word must be loaded MSB first. The positive-edge sensitive CLK and LE requires clean transitions. Standard logic families work well. When LE is high, 6-bit data in the serial input register is transferred to the outputs. When LE is high CLK is masked to prevent data transition during output loading.

When P/S is low, 3-wire SPI interface inputs (DATA, CLK, LE) are disabled and the serial input register is loaded asynchronously with parallel digital inputs (I0-I5). When LE is high, 6-bit parallel data is transferred.

For all modes of operations, the outputs will stay constant while LE is kept low.

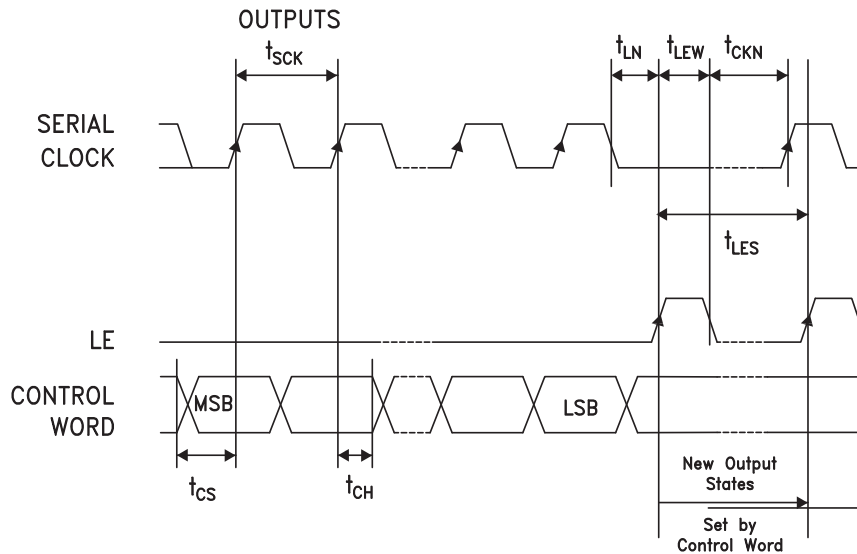

Parameter	Typ.
Min. serial period, t_{SCK}	100 ns
Control set-up time, t_{CS}	20 ns
Control hold-time, t_{CH}	20 ns
LE setup-time, t_{LN}	10 ns
Min. LE pulse width, t_{LEW}	10 ns
Min LE pulse spacing, t_{LES}	630 ns
Serial clock hold-time from LE, t_{CKN}	10 ns
Hold Time, t_{PH}	0 ns
Latch Enable Minimum Width, t_{LEN}	10 ns
Setup Time, t_{PS}	2 ns

Timing Diagram (Latched Parallel Mode)

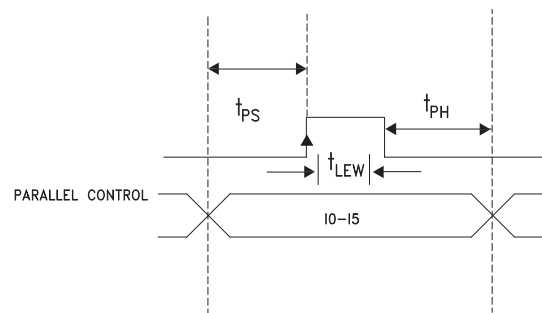

Parallel Mode (Direct Parallel Mode & Latched Parallel Mode)

Note: The parallel mode is enabled when P/S is set to low.

Direct Parallel Mode - Outputs are changed by the Control Voltage Inputs directly. The LE (Latch Enable) must be at a logic high to control in this manner.

Latched Parallel Mode - Outputs are selected using the Control Voltage Inputs and set while the LE is in the Low state. This will not change state while LE is Low. Once all Control Voltage Inputs are at the desired states the LE is pulsed. See timing diagram above for reference.

6-Bit SERIAL/PARALLEL SWITCH DRIVER/CONTROLLER

Power-Up States

If LE is set to logic LOW at power-up, the logic state of PUP1 and PUP2 determines the power-up state of the part per PUP truth table. If the LE is set to logic HIGH at power-up, the logic state of I5-I0 determines the power-up state of the part per truth table. The attenuator latches in the desired power-up state approximately 200 ms after power-up.

Control Voltage Table

State	Vdd = +3V	Vdd = +5V
Low	0 to 0.5V @ <1 μ A	0 to 0.8V @ <1 μ A
High	2 to 3V @ <1 μ A	2 to 5V @ <1 μ A

Power-On Sequence

The ideal power-up sequence is: GND, Vdd, Vee, Voph, digital inputs. The relative order of the digital inputs are not important as long as they are powered after Vdd / Vee / Voph / GND.

Truth Table

Input	Outputs	
	Bx	BxB
Low	Vee	Voph
High	Voph	Vee

PUP Truth Table

LE	PUP2	PUP1	Output States					
			B5	B4	B3	B2	B1	B0
0	0	0	0	0	0	0	0	0
0	0	1	0	1	0	0	0	0
0	1	0	1	0	0	0	0	0
0	1	1	1	1	1	1	1	1
1	X	X	Set by the inputs Ix					

For the Inputs (LE, PUP1, PUP2), Logic "0" = 0V and Logic "1" = Vdd

For the outputs, Logic "0" is Bx = Vee, BxB = Voph, and Logic "1" is Bx = Voph, BxB = Vee

**6-Bit SERIAL/PARALLEL SWITCH
DRIVER/CONTROLLER**

Absolute Maximum Ratings

Digital Inputs (I0-I5, Shift Clock, Latch Enable, P/S, PUP and Data Inputs)	-0.5 to Vdd +0.5V
Bias Voltage (Vdd)	5.6 V
Bias Voltage (Vee)	-5.6 V
Bias Voltage (Voph)	2.3 V
Channel Temperature	125 °C
Continuous Pdiss (T = 85 °C) (derate 8.2 mW/°C above 85 °C) [1]	325 mW
Thermal Resistance (Channel to ground paddle)	123 °C/W
Storage Temperature	-65 to +150 °C
Operating Temperature	-40 to +85 °C



**ELECTROSTATIC SENSITIVE DEVICE
OBSERVE HANDLING PRECAUTIONS**

Outline Drawing

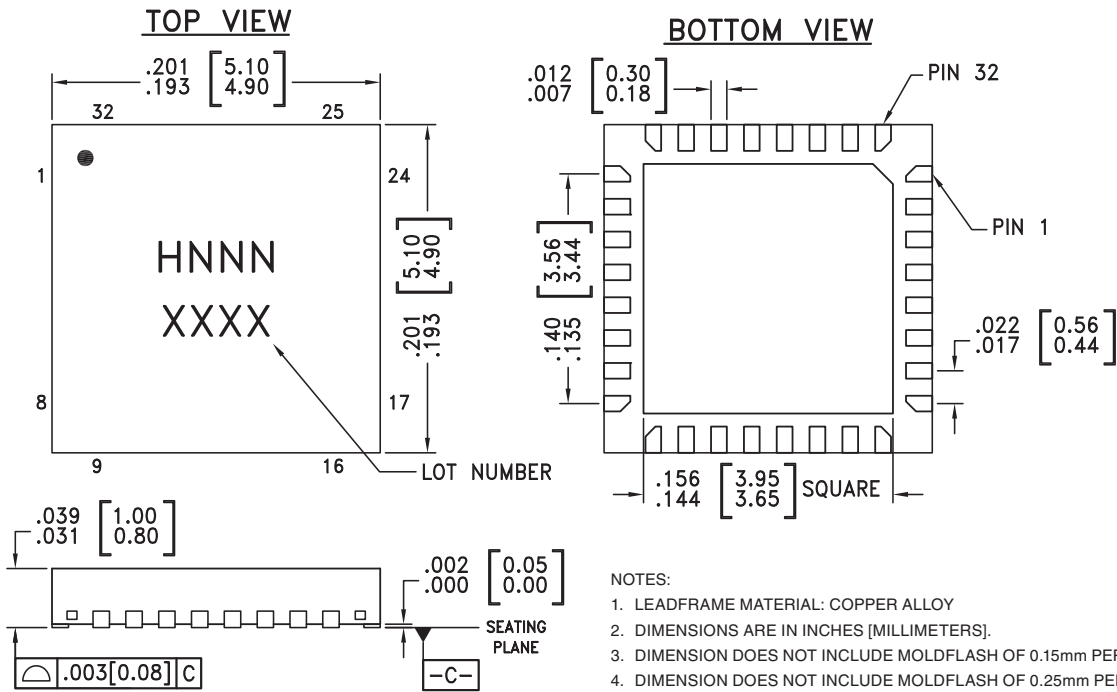

Package Information

Part Number	Package Body Material	Lead Finish	MSL Rating	Package Marking [3]
HMC677LP5	Low Stress Injection Molded Plastic	Sn/Pb Solder	MSL1 [1]	H677 XXXX
HMC677LP5E	RoHS-compliant Low Stress Injection Molded Plastic	100% matte Sn	MSL1 [2]	H677 XXXX

[1] Max peak reflow temperature of 235 °C

[2] Max peak reflow temperature of 260 °C

[3] 4-Digit lot number XXXX

For price, delivery, and to place orders, please contact Hittite Microwave Corporation:
20 Alpha Road, Chelmsford, MA 01824 Phone: 978-250-3343 Fax: 978-250-3373
Order On-line at www.hittite.com

**6-Bit SERIAL/PARALLEL SWITCH
DRIVER/CONTROLLER**

Pin Descriptions

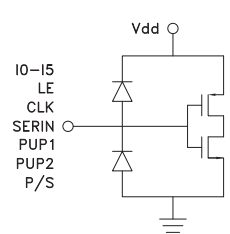
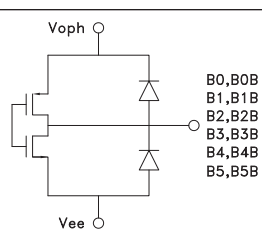
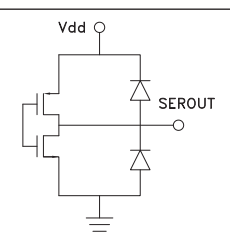
Pin Number	Function	Description	Interface Schematic
1, 29	Vdd1, Vdd2	Supply Voltage	
2 - 7	I0 - I5	See Truth Table, Control Voltage Table and Timing Diagram	
9	P/S		
10	CLK		
11	SERIN		
12	LE		
31, 32	PUP2, PUP1		
8, 13, 14	N/C	No connection necessary. These pins may be connected to DC ground.	
15, 17, 19, 21, 23, 25	B0 - B5	Complementary Outputs	
16, 18, 20, 22, 24, 26	B0B - B5B		
27	Vee	Negative Supply.	
28	VOPH	User selectable output high voltage 0 to +2.2V	
30	SEROUT	Serial input data delayed by six clock cycles.	

6-Bit SERIAL/PARALLEL SWITCH DRIVER/CONTROLLER

Application & Evaluation PCB Schematic

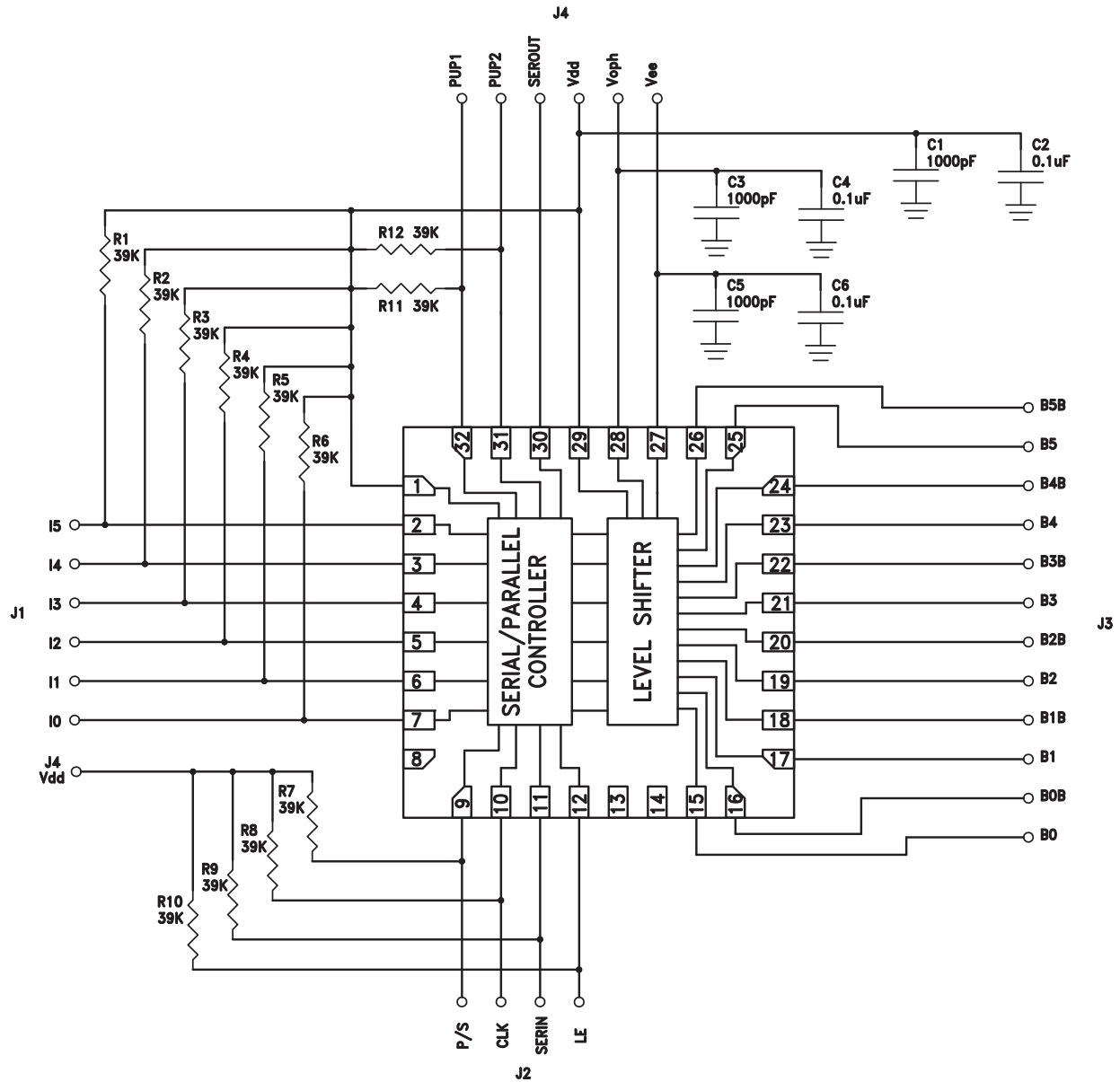

6-Bit SERIAL/PARALLEL SWITCH DRIVER/CONTROLLER

Evaluation PCB

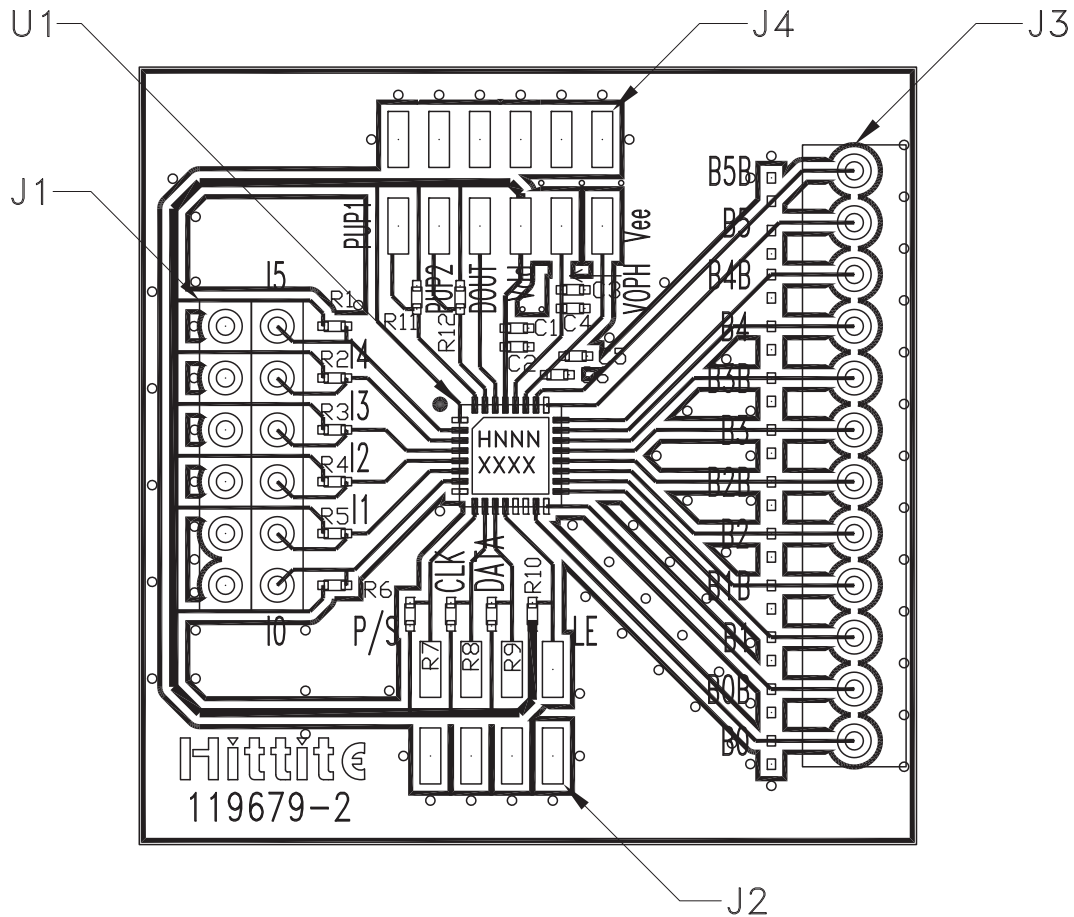

List of Materials for Evaluation PCB 119681 ^{[1][3]}

Item	Description
C1, C3, C5	1000 pF Capacitor, 0402 Pkg.
C2, C4, C6	0.1 μ F Capacitor, 0402 Pkg.
J1 - J4	Multi Pin DC Connector
R1 - R12	39k Ω Resistor, 0402 Pkg.
U1	HMC677LP5(E) 6-Bit Digital Level Shifter
PCB ^[2]	119679 Evaluation PCB

[1] Reference this number when ordering complete evaluation PCB

[2] Circuit Board Material: FR4

[3] Please refer to part's pin description and functional diagram for pin out assignments on evaluation board.

The evaluation circuit board shown is available from Hittite upon request.



Компания «ЭлектроПласт» предлагает заключение долгосрочных отношений при поставках импортных электронных компонентов на взаимовыгодных условиях!

Наши преимущества:

- Оперативные поставки широкого спектра электронных компонентов отечественного и импортного производства напрямую от производителей и с крупнейших мировых складов;
- Поставка более 17-ти миллионов наименований электронных компонентов;
- Поставка сложных, дефицитных, либо снятых с производства позиций;
- Оперативные сроки поставки под заказ (от 5 рабочих дней);
- Экспресс доставка в любую точку России;
- Техническая поддержка проекта, помощь в подборе аналогов, поставка прототипов;
- Система менеджмента качества сертифицирована по Международному стандарту ISO 9001;
- Лицензия ФСБ на осуществление работ с использованием сведений, составляющих государственную тайну;
- Поставка специализированных компонентов (Xilinx, Altera, Analog Devices, Intersil, Interpoint, Microsemi, Aeroflex, Peregrine, Syfer, Eurofarad, Texas Instrument, Miteq, Cobham, E2V, MA-COM, Hittite, Mini-Circuits, General Dynamics и др.);

Помимо этого, одним из направлений компании «ЭлектроПласт» является направление «Источники питания». Мы предлагаем Вам помощь Конструкторского отдела:

- Подбор оптимального решения, техническое обоснование при выборе компонента;
- Подбор аналогов;
- Консультации по применению компонента;
- Поставка образцов и прототипов;
- Техническая поддержка проекта;
- Защита от снятия компонента с производства.



Как с нами связаться

Телефон: 8 (812) 309 58 32 (многоканальный)

Факс: 8 (812) 320-02-42

Электронная почта: org@eplast1.ru

Адрес: 198099, г. Санкт-Петербург, ул. Калинина, дом 2, корпус 4, литера А.